

Recommendations: Interface

Recommendation regarding payload variations:

A. This should be reviewed in more detail ...

Recommendations regarding coupled structural dynamics:

B. More modeling effort should be made to address issues of coupled structural resonances and the tradeoffs. ... we recommend that additional personnel be drafted to evaluate the modeling done to date and address the issues above.

C. As a second priority, substituting a reasonable approximation to the quad suspension for the current payload on the ETF could help give confidence in the recommended modeling work.

Recommendation regarding off-loading payload:

D. The alternative for off-loading payload should be evaluated, if modeling of coupled dynamics in the control schemes above cannot resolve the raised.

Progress on Interface

Rotation student Melissa Lincoln adapted a Caltech LOS (from Janeen and Calum) to resonate at 70 Hz. Equipped with 2 small geophones with good readouts.

Ready to go into ETF when the opportunity arises.



Recommendations: Performance Risks

- A. Wait for additional ETF results for 1 Hz and 10 Hz.
- B. Testing pier amplification hypothesis in LASTI.
- C. Study the feasibility of lowering the stage eigenfrequencies of the BSC.
- D. The committee needs to review the overall projections for 10 Hz test mass displacement noise, ...
- E. Examine time-domain performance of the ETF.
- F. Focus on 1 Hz performance.
- G. Analyze thermal behavior.
- H. Ignore the sensor noise for now.
- I. Design for reliability.
- J. Make plots to compare predictions, requirements, and results.

AdvLIGO Isolation and Alignment

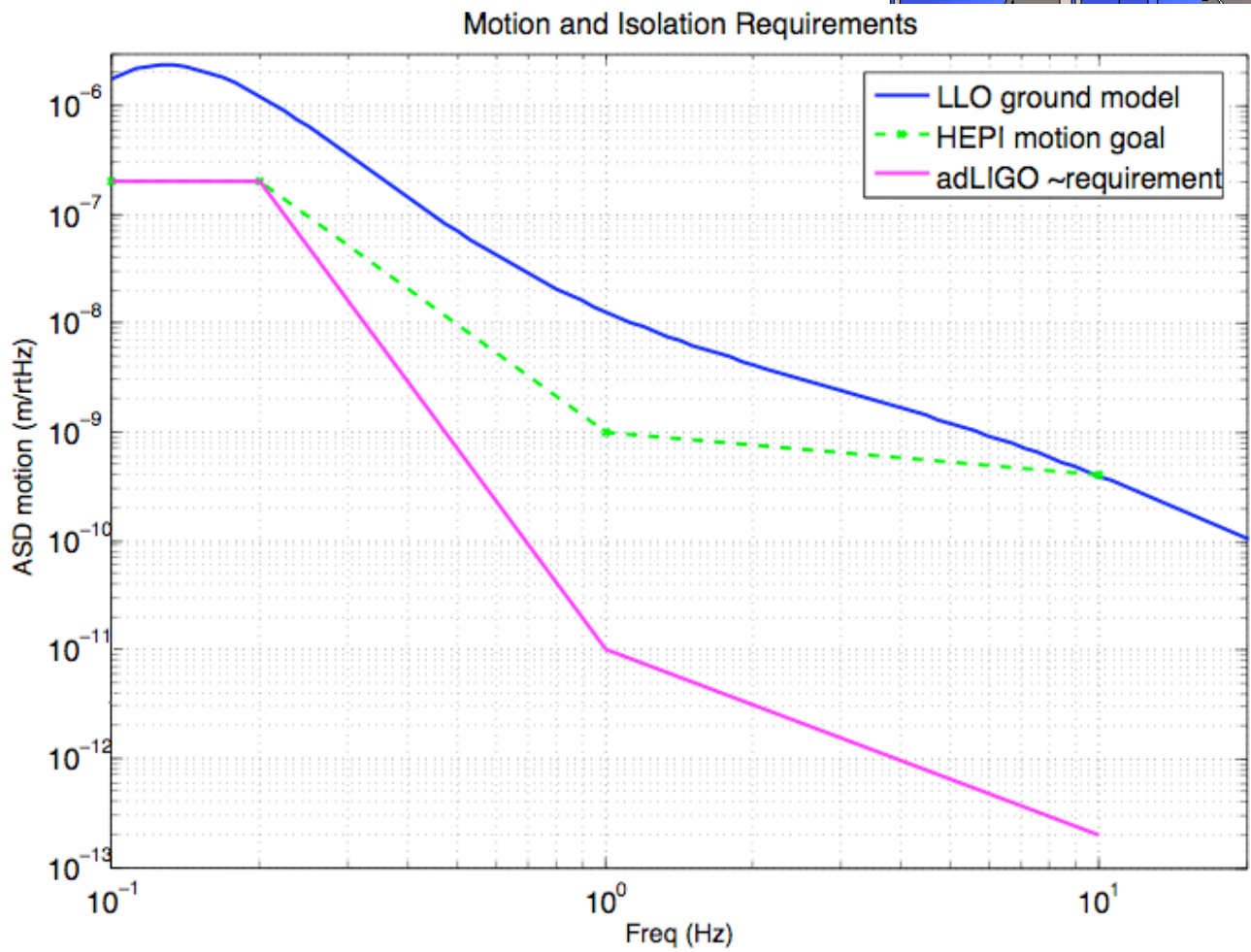
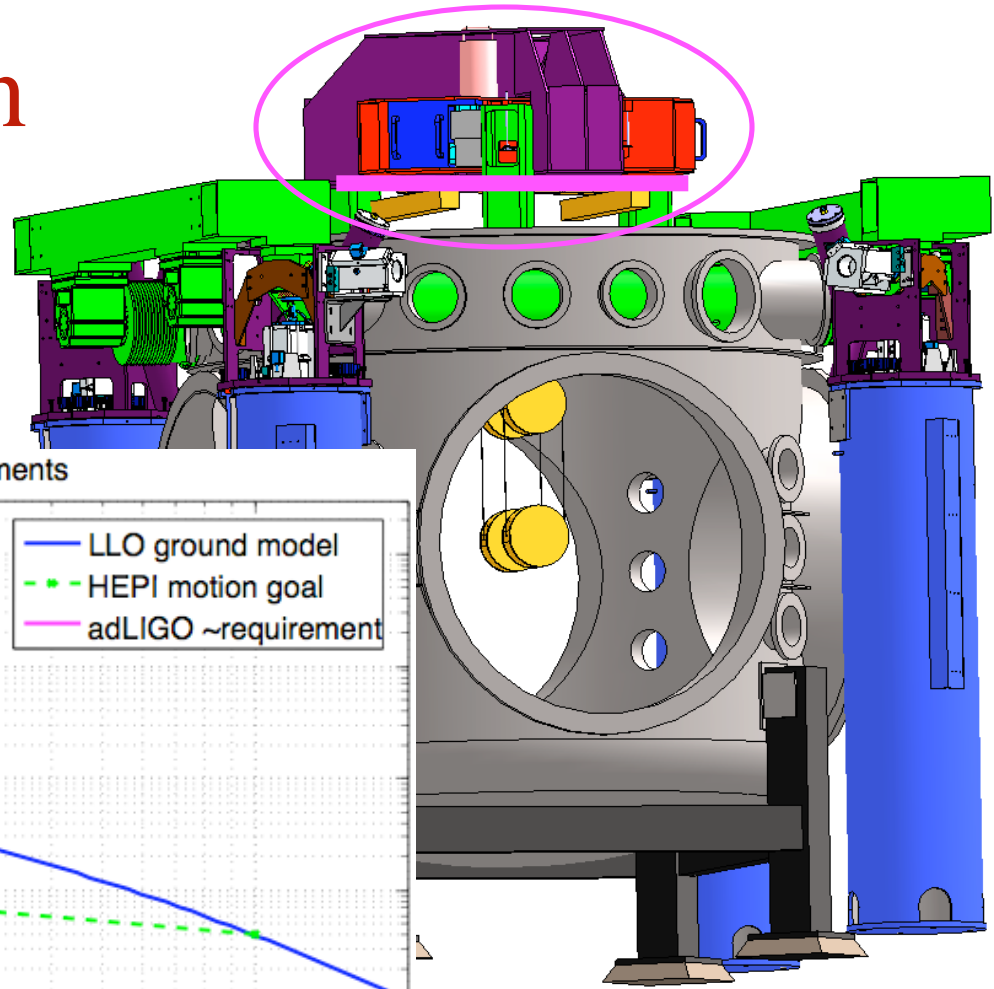

Control Steps

1. Close damping loops in 6 DOF for each stage.
2. Create “super-sensor” in the “center basis”
blending sensors: 3/DOF on stage 1, 2/DOF on stage 2.
Start with 2 Hz blend.
3. Close the isolation loops for 2-stage internal system.
Stage 1 tip & tilt (rx & ry)
Stage 1 x, y, z, & rz.
Stage 2 tip & tilt,
Stage 2 x, y, z, & rz.
4. Generate & implement “displacement-sensor orientation correction” matrix for stage 1.
5. Lower the blend frequencies to get 1 Hz performance.

Example Control Loops Stage 1, X

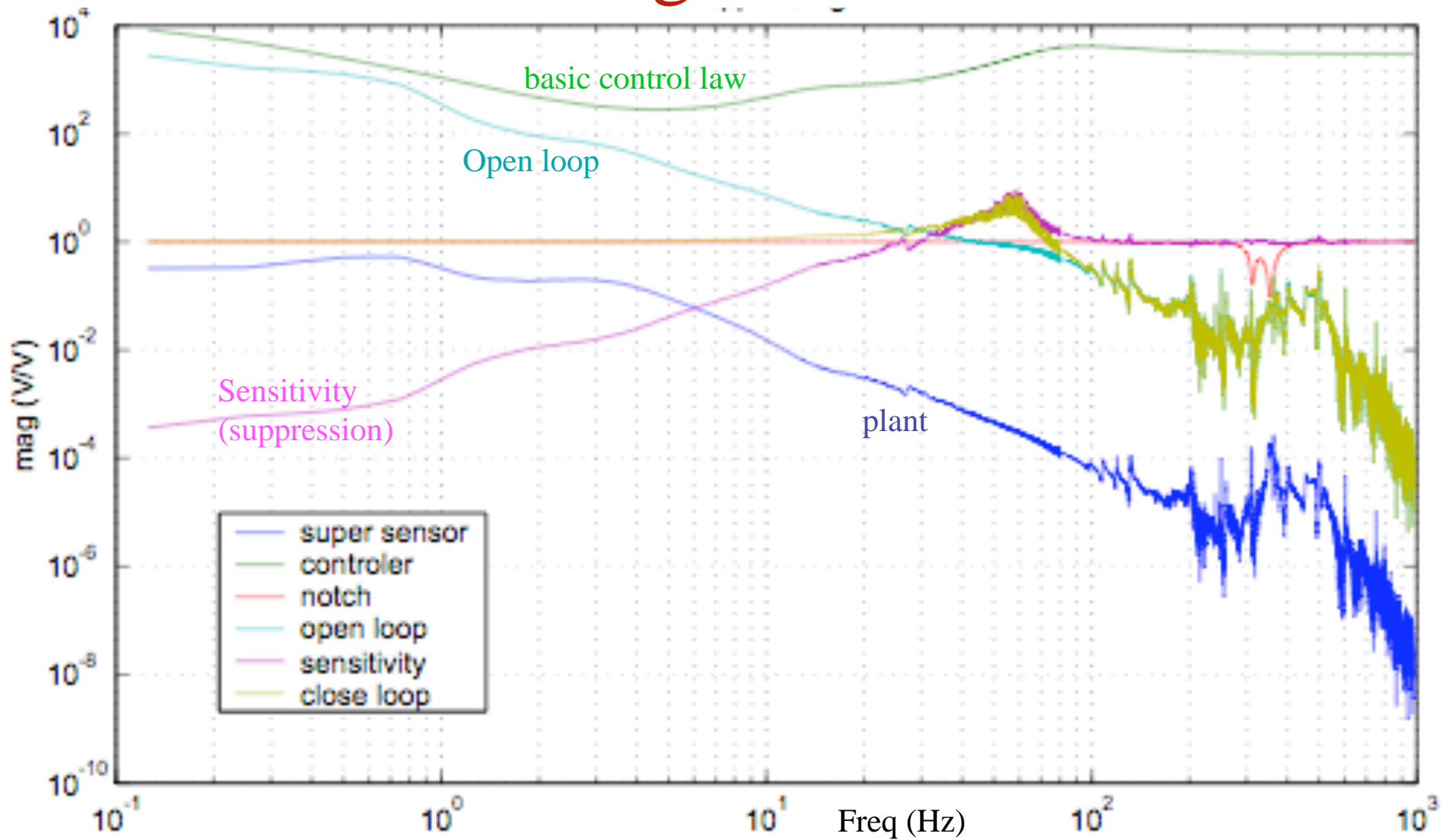

Example Control Loops Stage 2, X

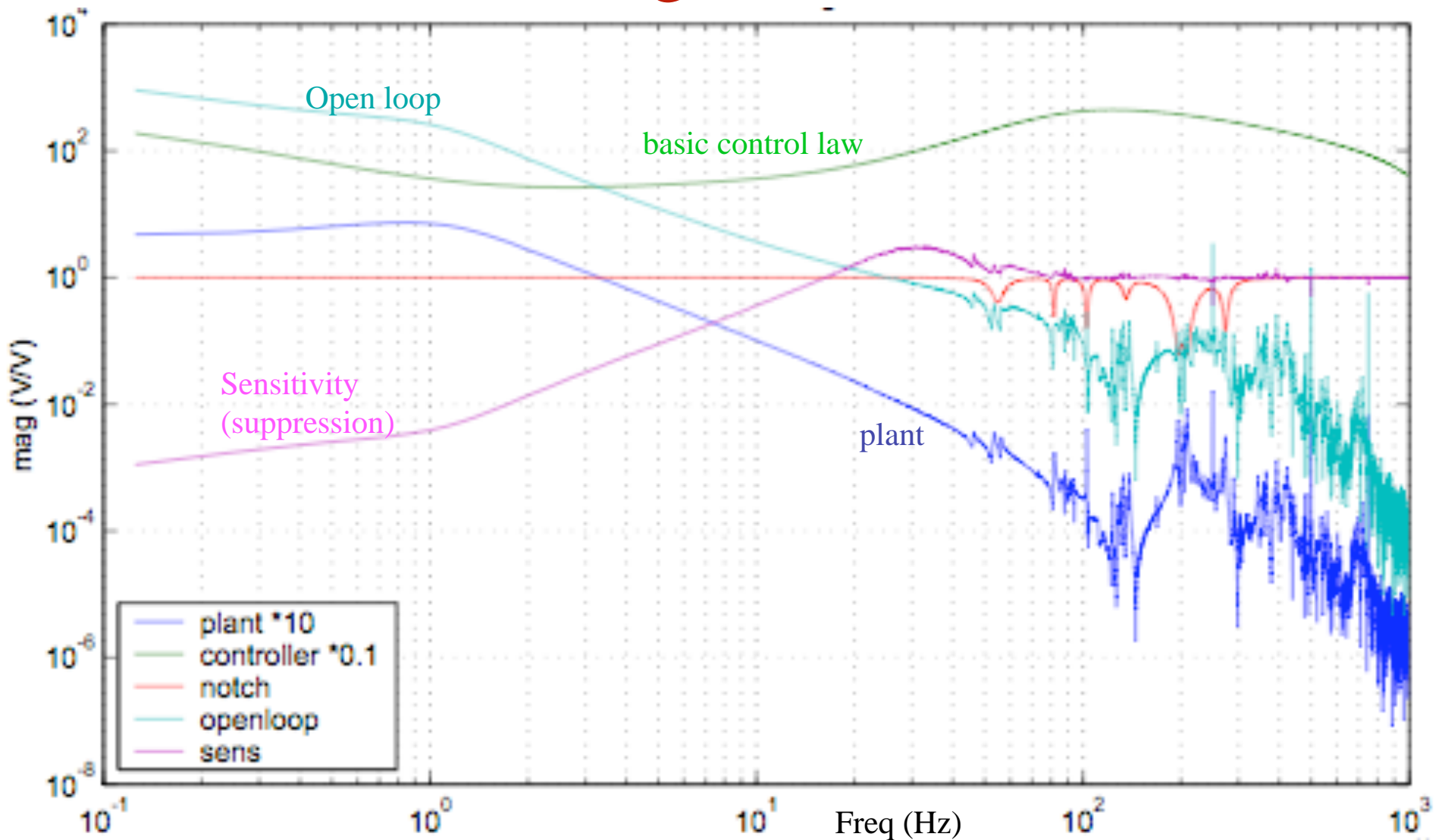

Displacement-sensor Orientation Correction

Problem: Tilt-horizontal coupling

Non-parallel reference surfaces can convert translation into tilt.

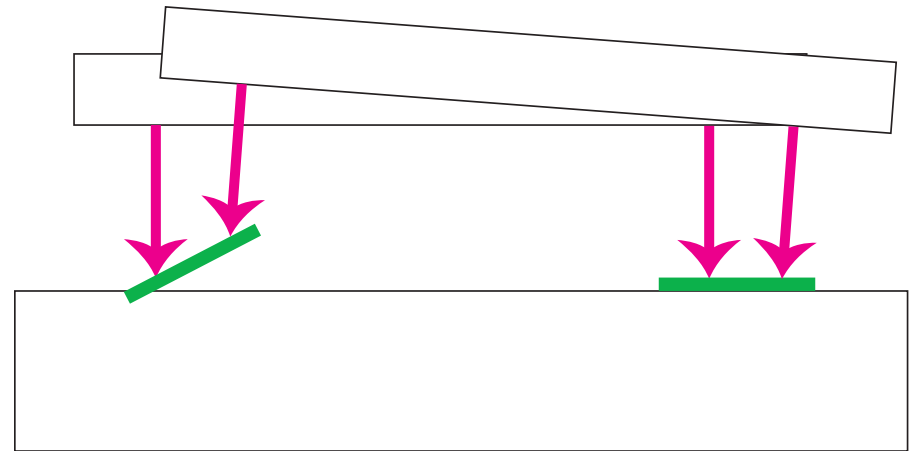

Drive system in translation

Measure tilt with horizontal seismometer

Calculate the ratio of translation-to-tilt coupling

Modify code: when you command a translation, also command an opposite tilt

Benefit of Displacement-sensor orientation correction

Alignment Improvement for X to X coupling

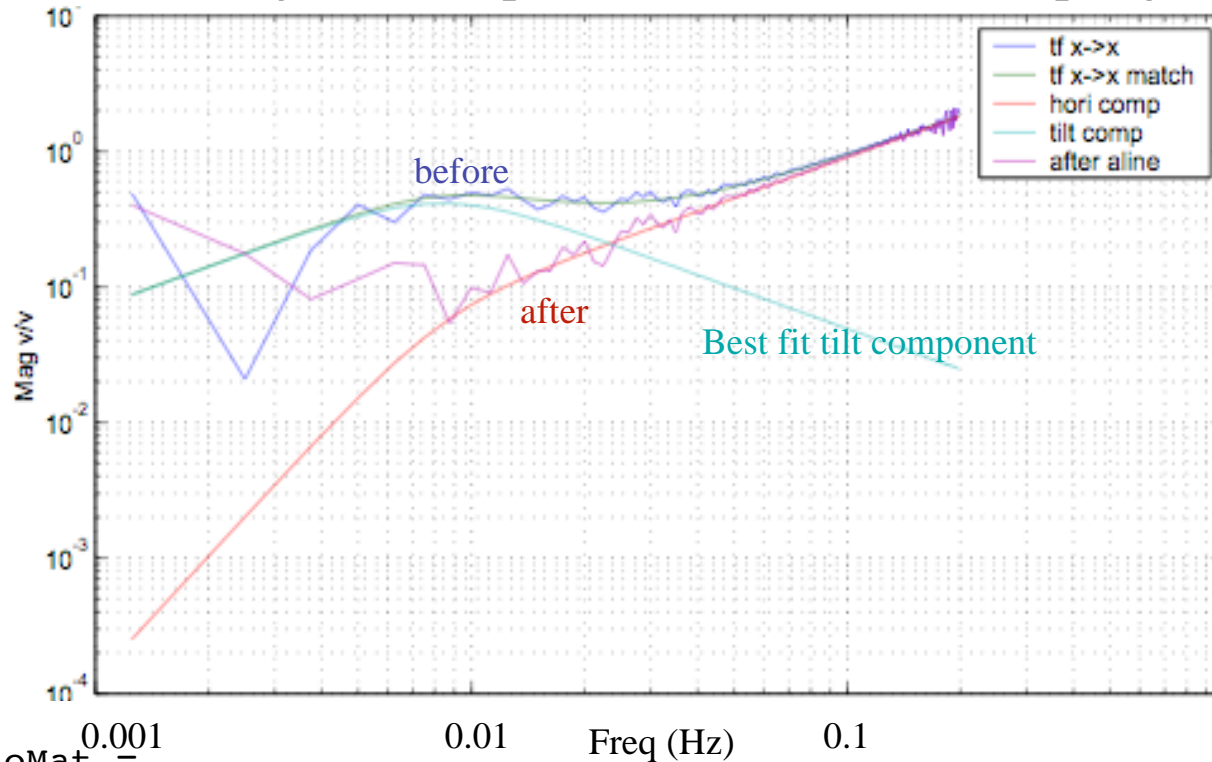

alineMat =

$$\begin{bmatrix} x \\ y \\ z \\ rx \\ ry \\ rz \end{bmatrix} = \begin{bmatrix} 1.0000 & 0 & 0 & 0 & 0 & 0 \\ 0 & 1.0000 & 0 & 0 & 0 & 0 \\ 0 & 0 & 1.0000 & 0 & 0 & 0 \\ 0 & -0.0006 & -0.0116 & 1.0000 & 0 & 0 \\ 0.0022 & 0 & 0.0147 & 0 & 1.0000 & 0 \\ 0 & 0 & 0 & 0 & 0 & 1.0000 \end{bmatrix} * \begin{bmatrix} x \\ y \\ z \\ rx \\ ry \\ rz \end{bmatrix}$$

Lower the blend frequencies

Goal: Factor of 100 isolation at 1 Hz without using sensor correction

In our current implementation,

First, normalize all sensors to match dynamics of displacement sensor

Then, design blend filters which add to 1

Benefits:

- Simplifies design of the blending filters.
- Moving blend frequency doesn't change the control loop.
- Total change of filters doesn't change the control loop.

Drawbacks:

- Inverting inertial sensors gives many unwanted zero-frequency poles.
- Have to develop techniques to cancel these effectively.

Stage 1 Blending

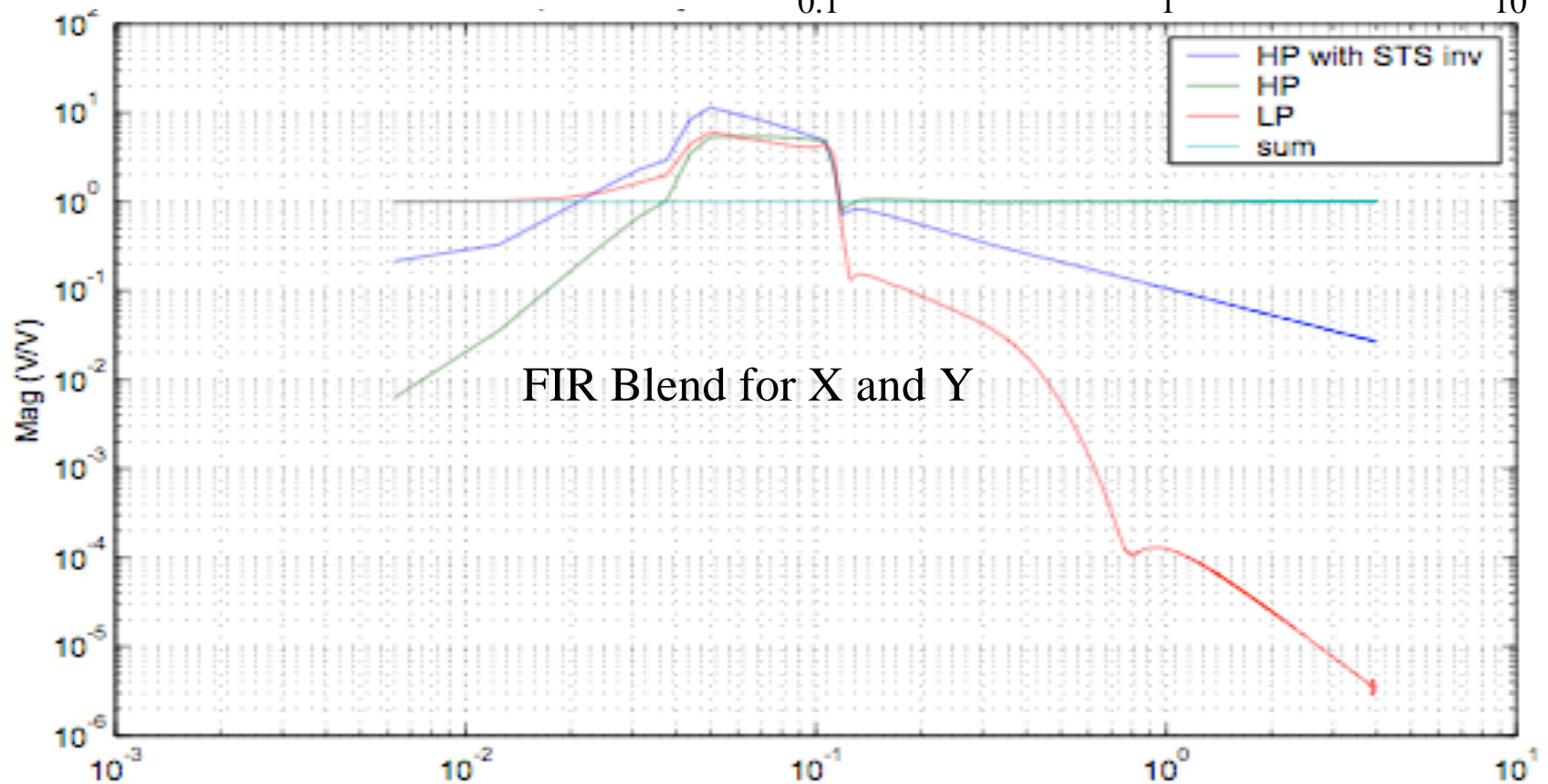
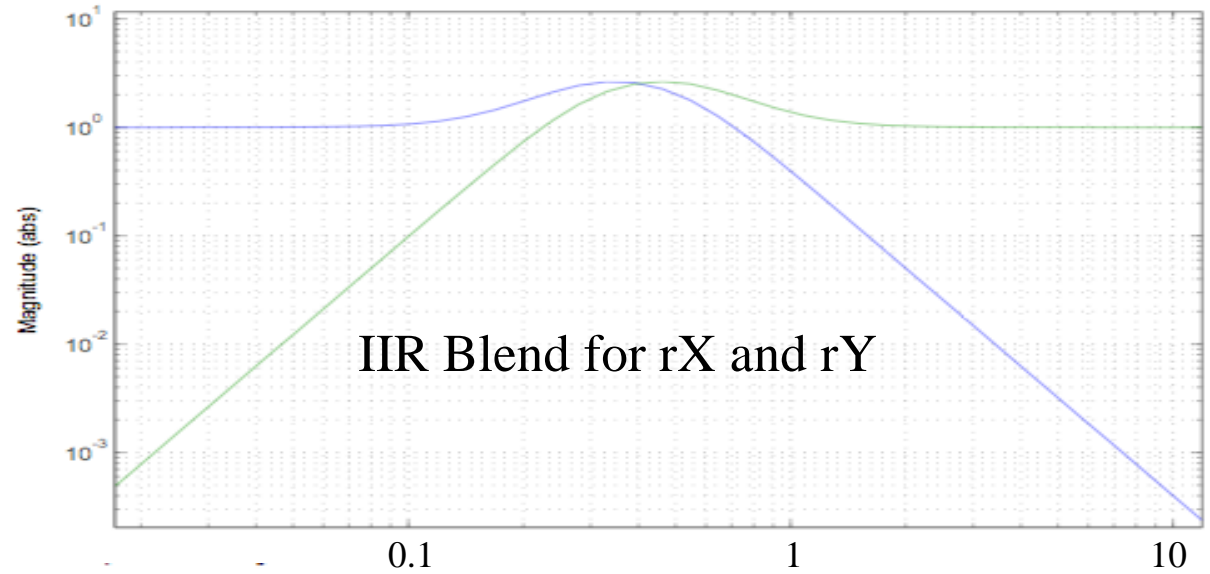

Blend filter for stage 2

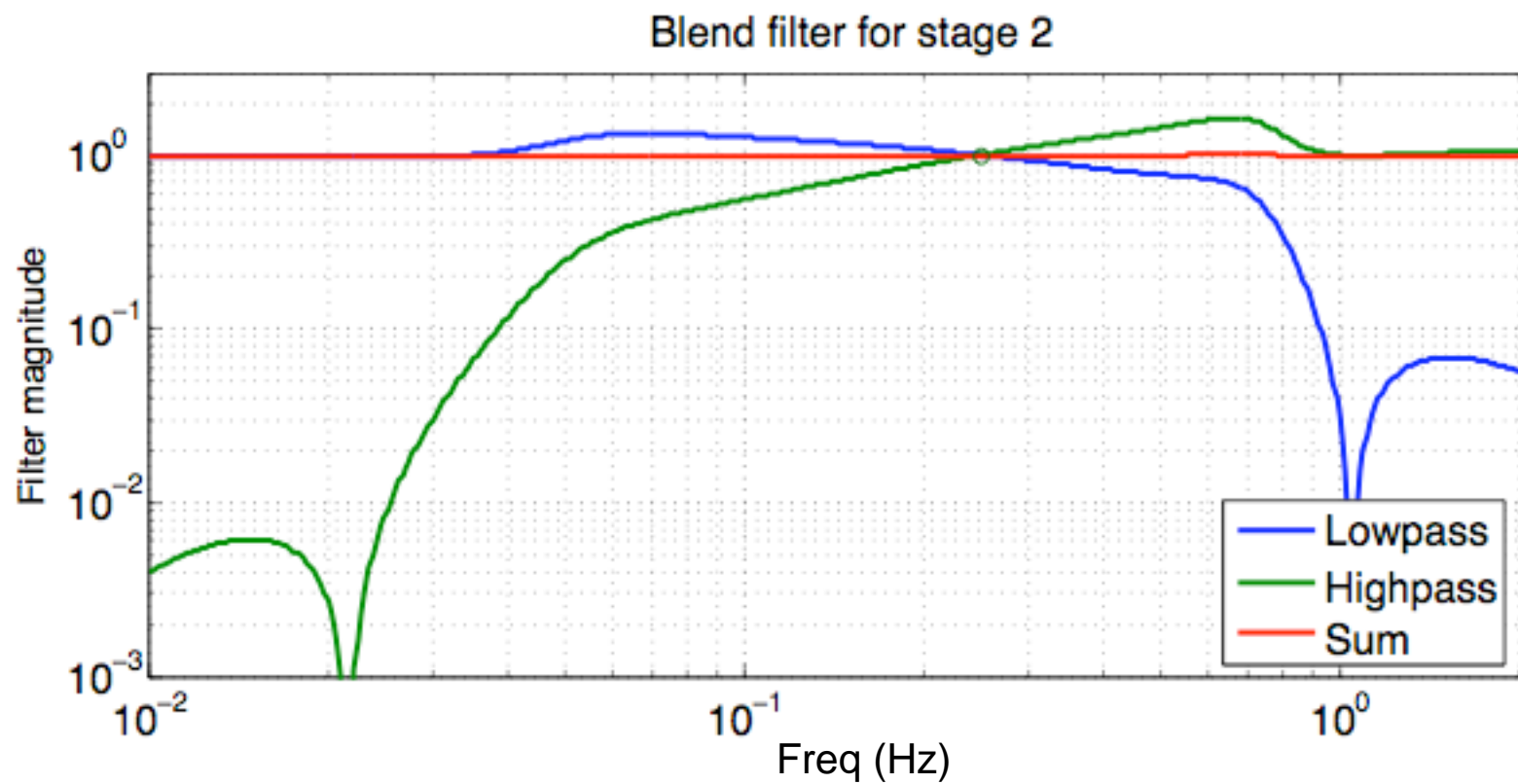

Performance in X

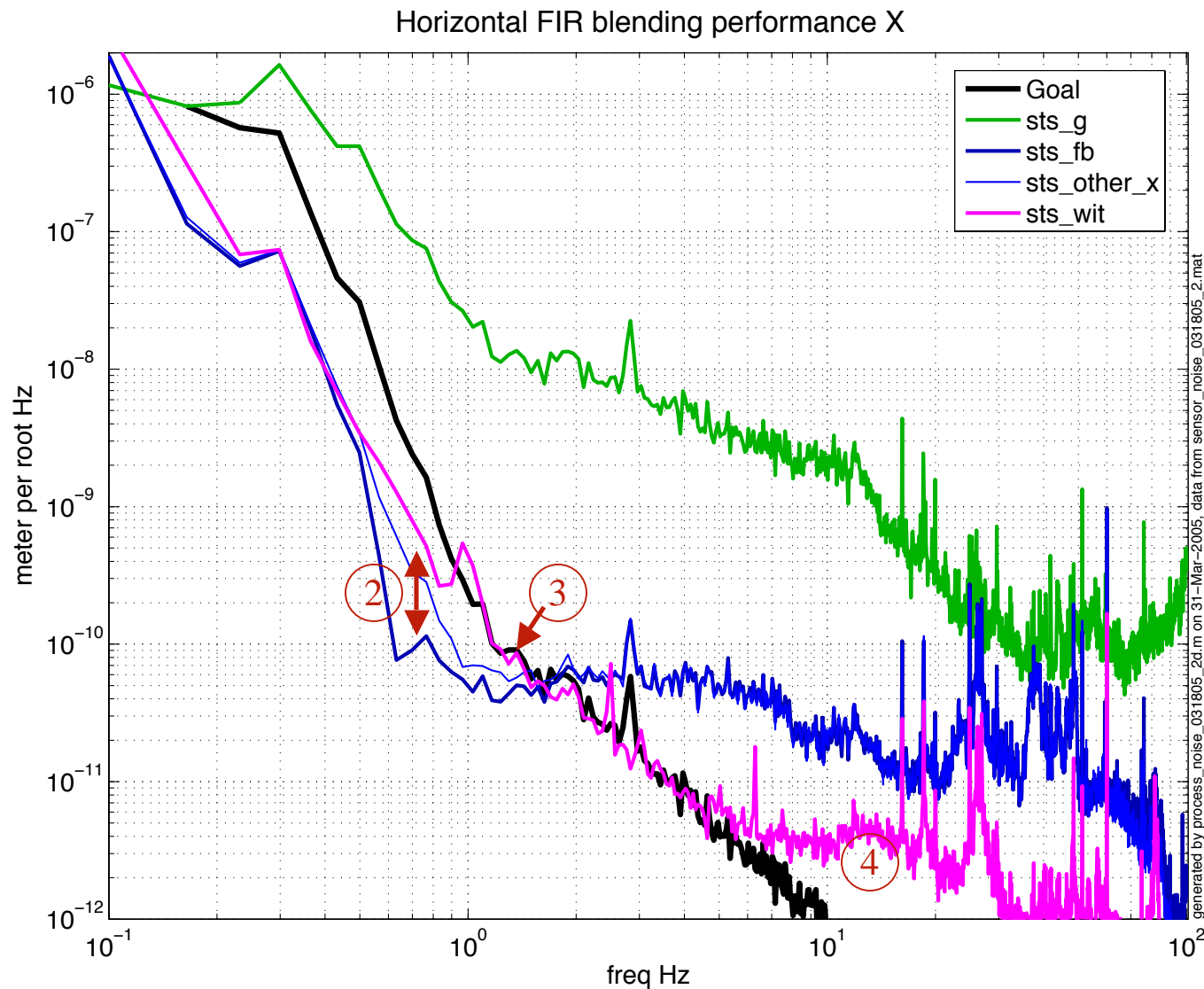

Notice:

1. We have a factor of 100 isolation at 1 Hz
2. Stage 2 moves more than stage 1 at 0.8 Hz
3. Stage 2 doesn't get to $1e^{-11}$ m/rtHz near 1 Hz.
4. There's a bump around 11 Hz.

Performance in Y

Horizontal FIR blending performance Y

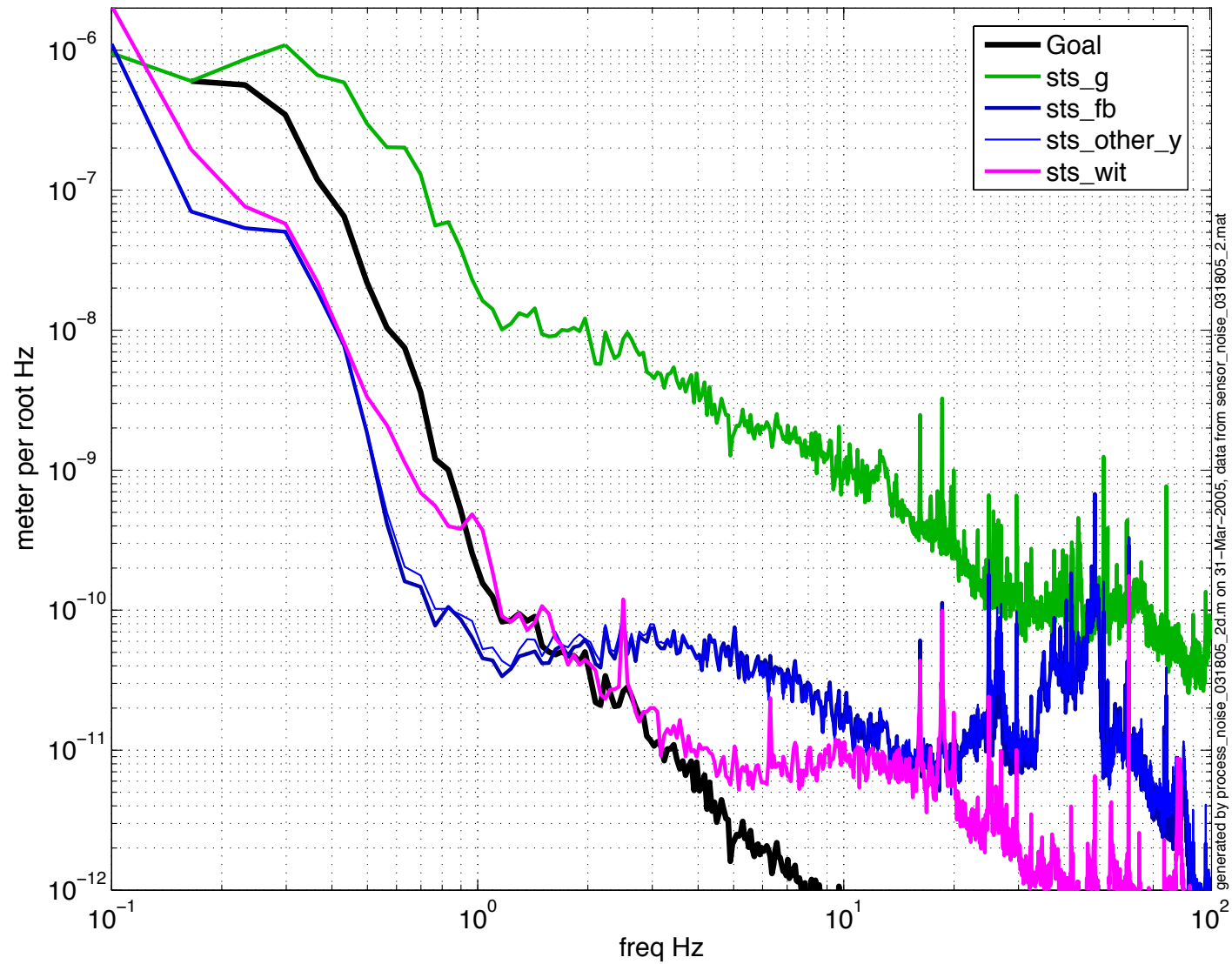

generated by process_noise_031805_2d.m on 31-Mar-2005, data from sensor_noise_031805_2.mat

Performance in Z

Vertical FIR blending performance Z

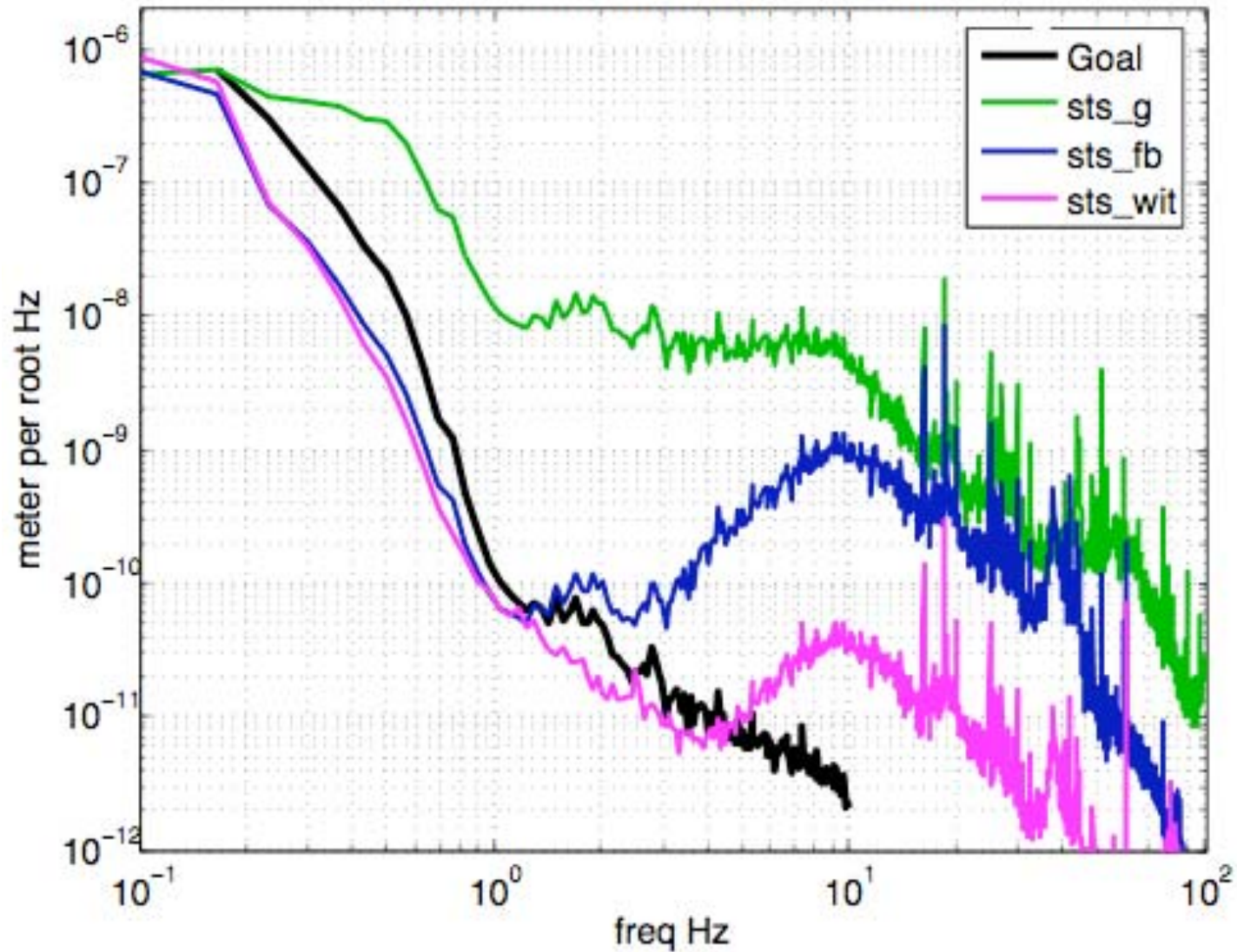

Sensor Noise on Stage 2

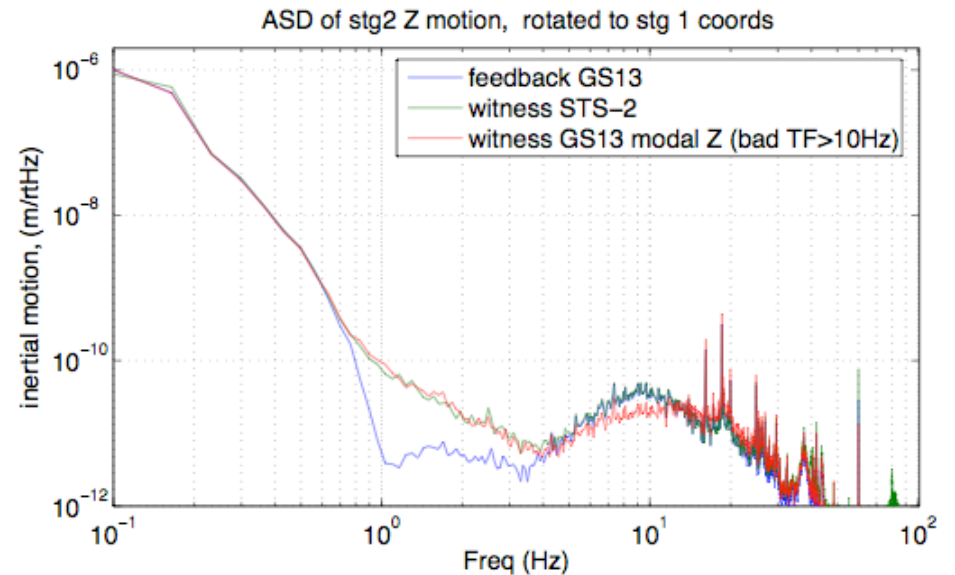
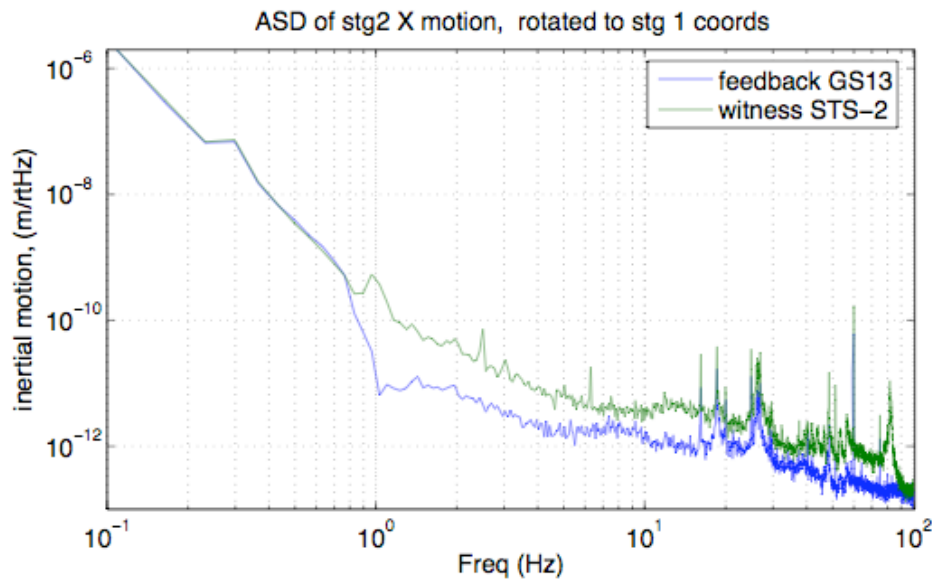
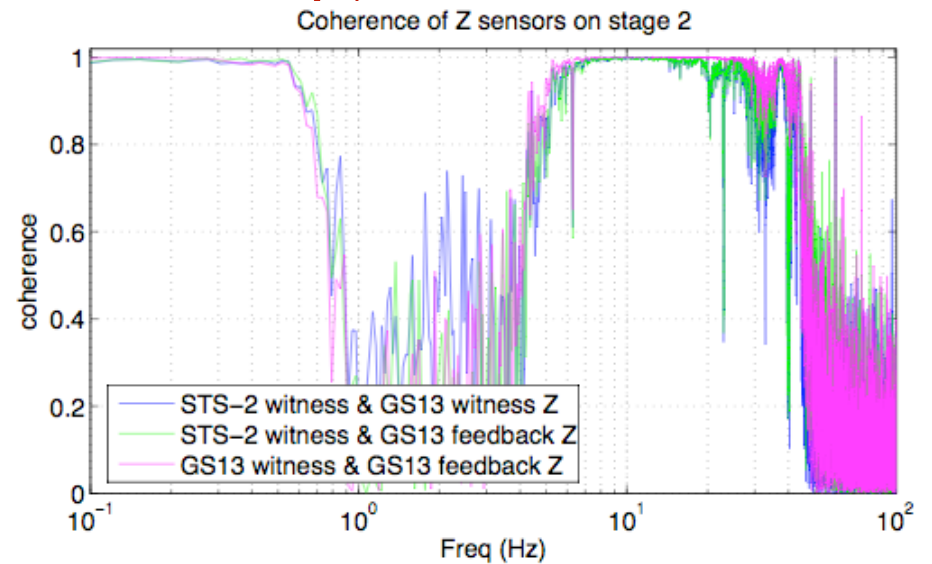
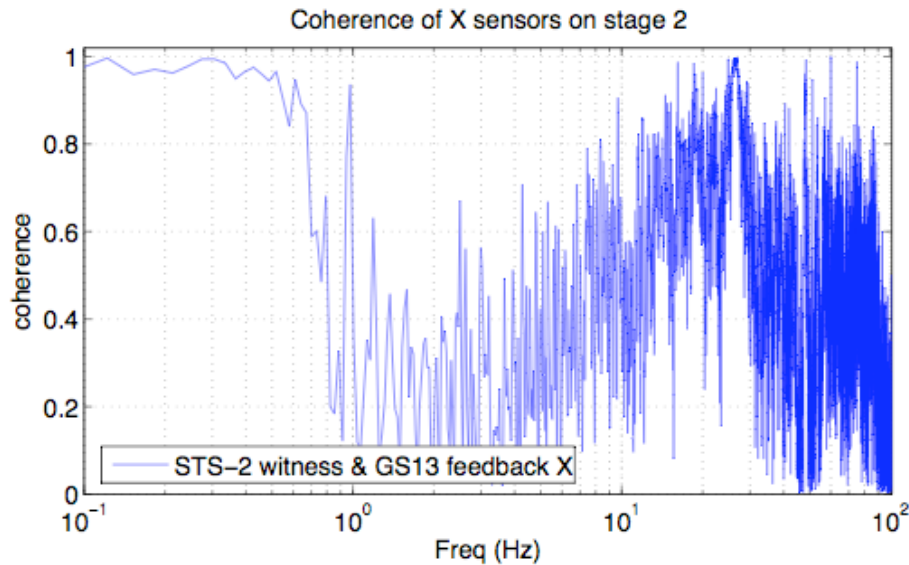

Excess Noise at 1 Hz, X

Stage 1 is Isolated, Stage 2 is Damped

Horizontal FIR blending performance X

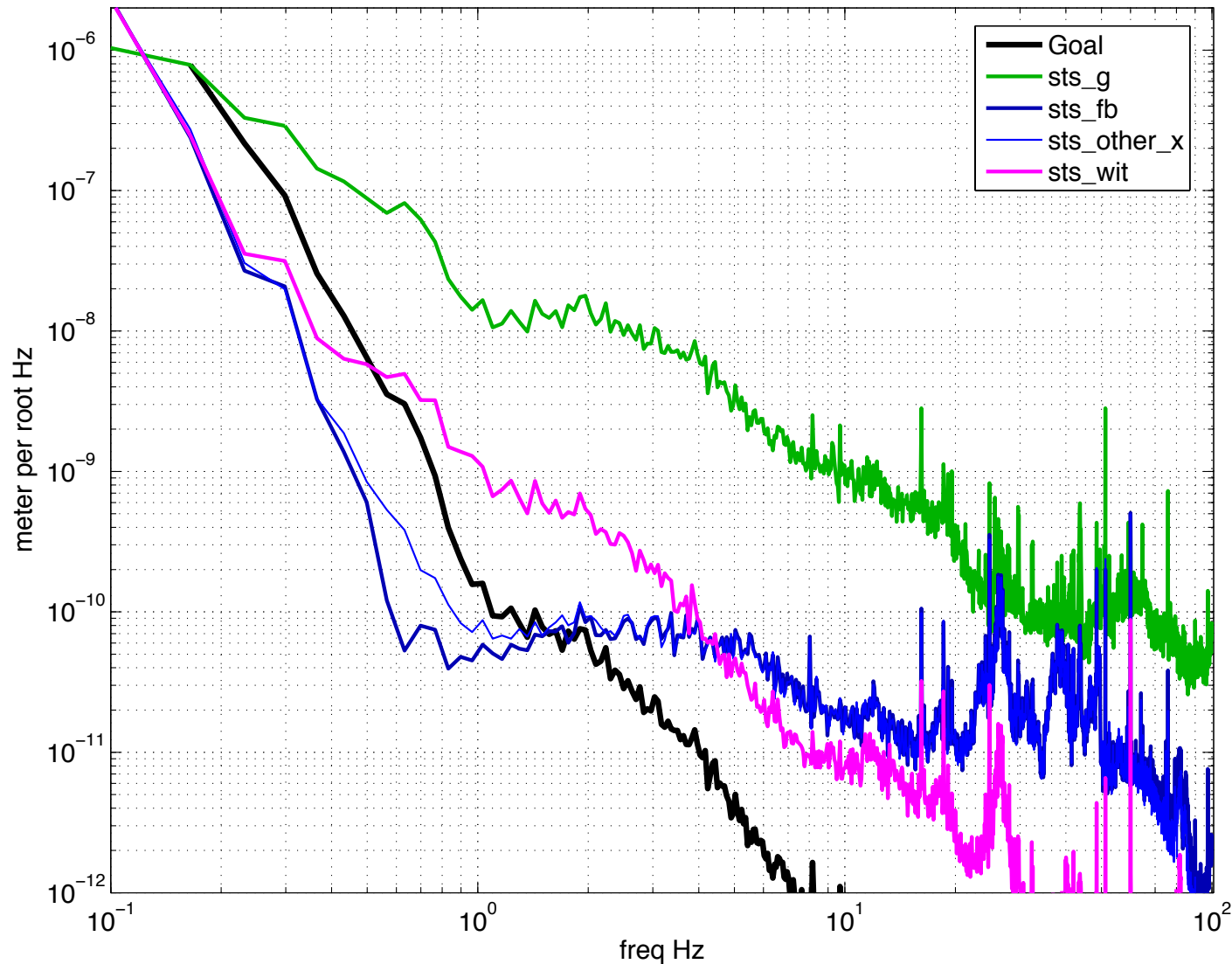

Excess Noise at 1 Hz, Y

Stage 1 is Isolated, Stage 2 is Damped

Horizontal FIR blending performance Y

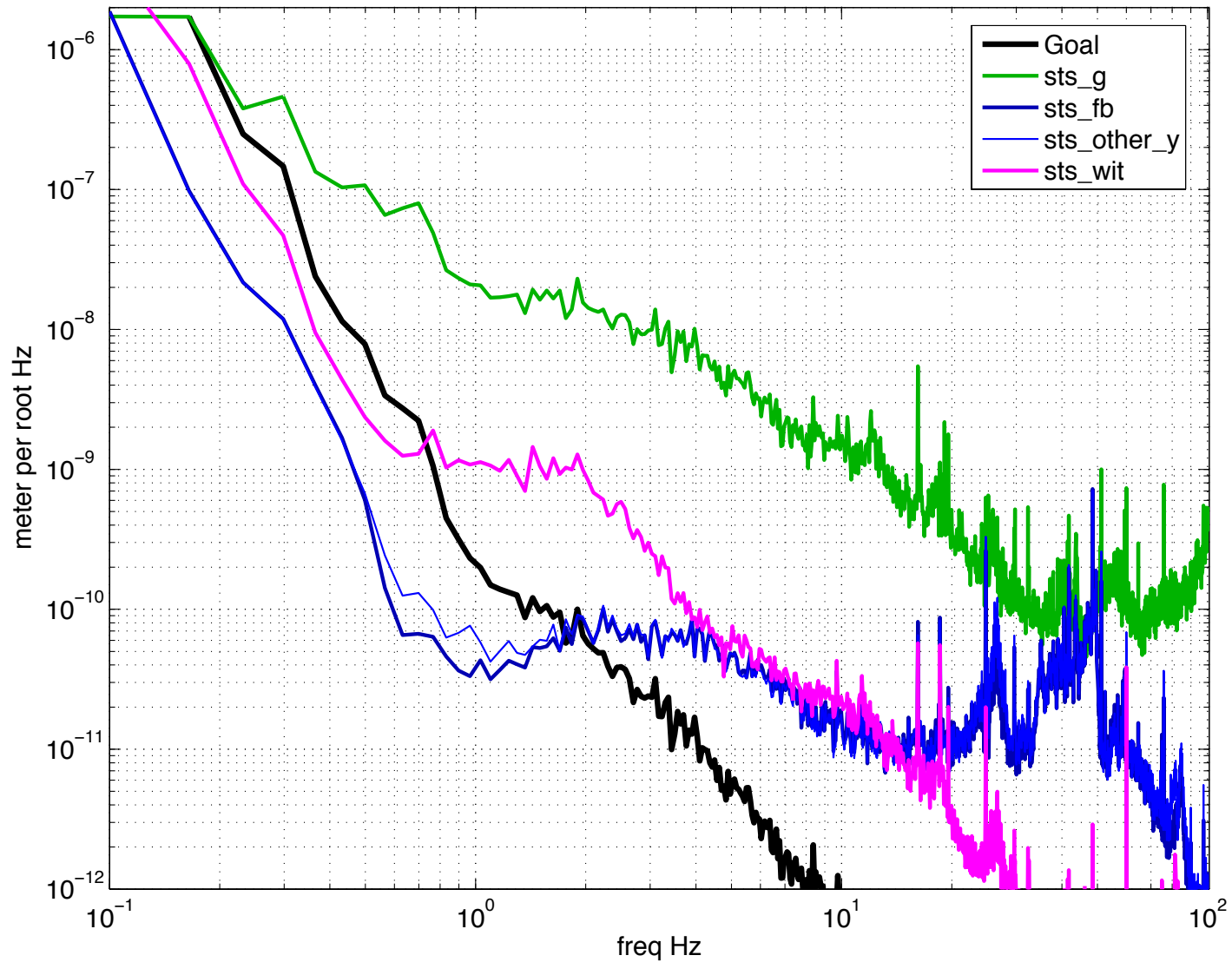

Excess Noise at 1 Hz, Z

Stage 1 is Isolated, Stage 2 is Damped

Vertical FIR blending performance Z

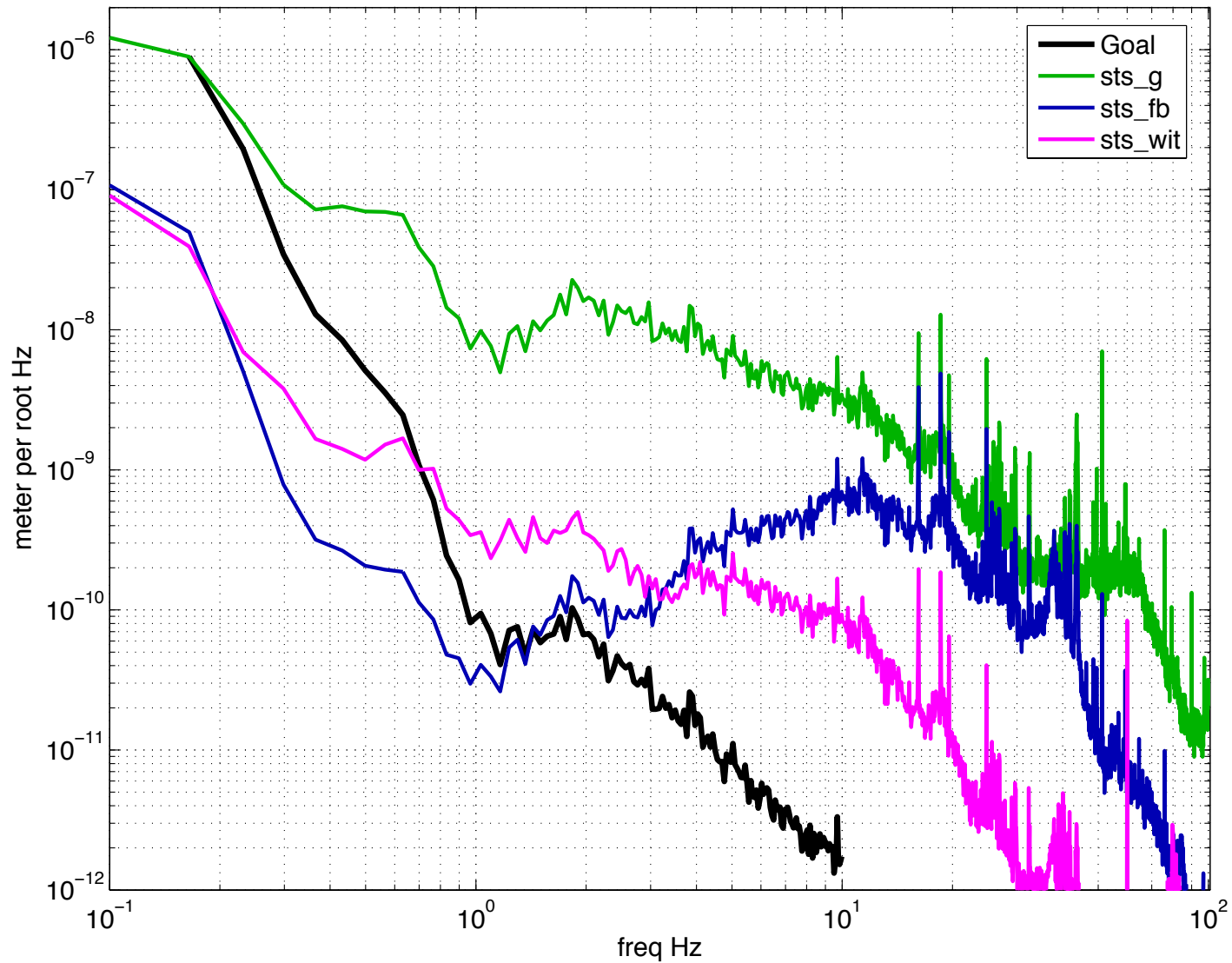

Large Rotation Motion on Stage 1

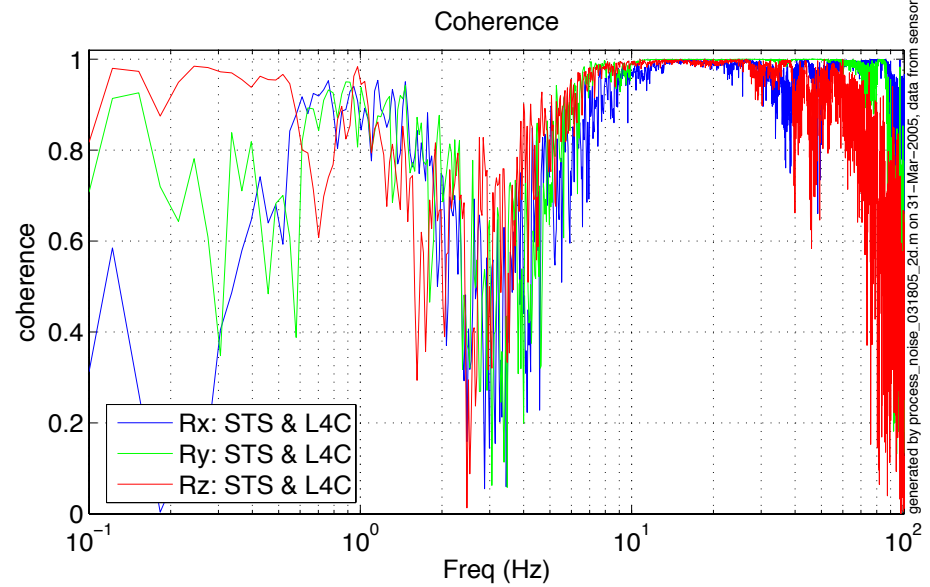
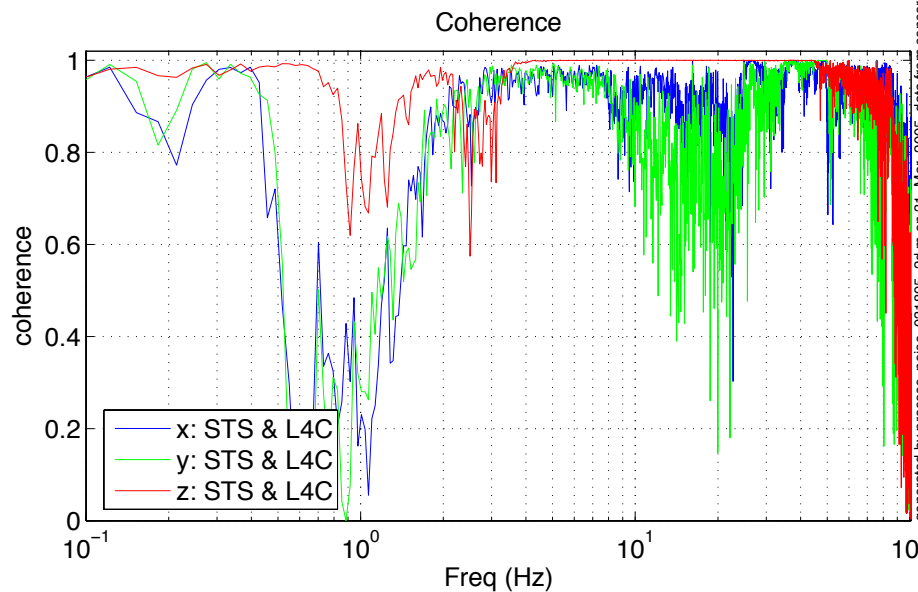
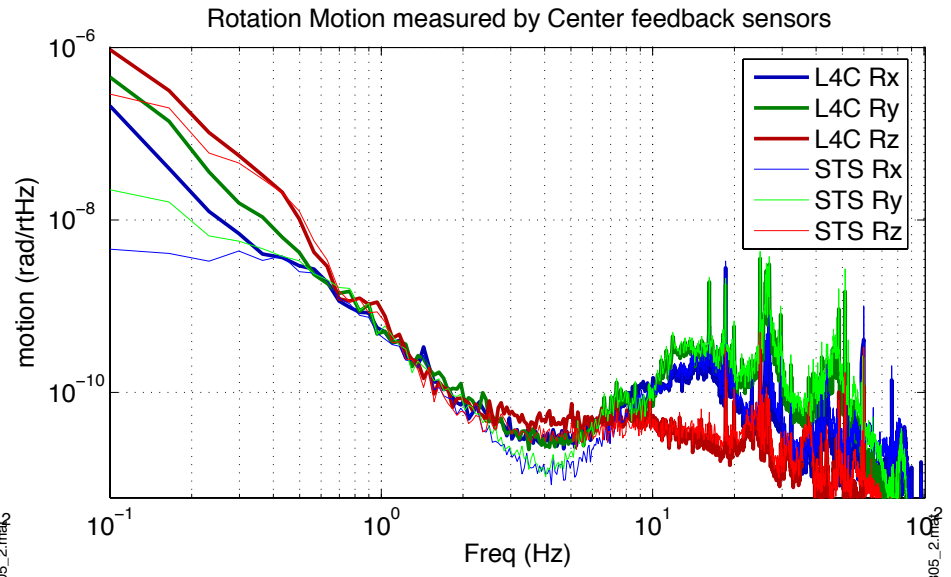
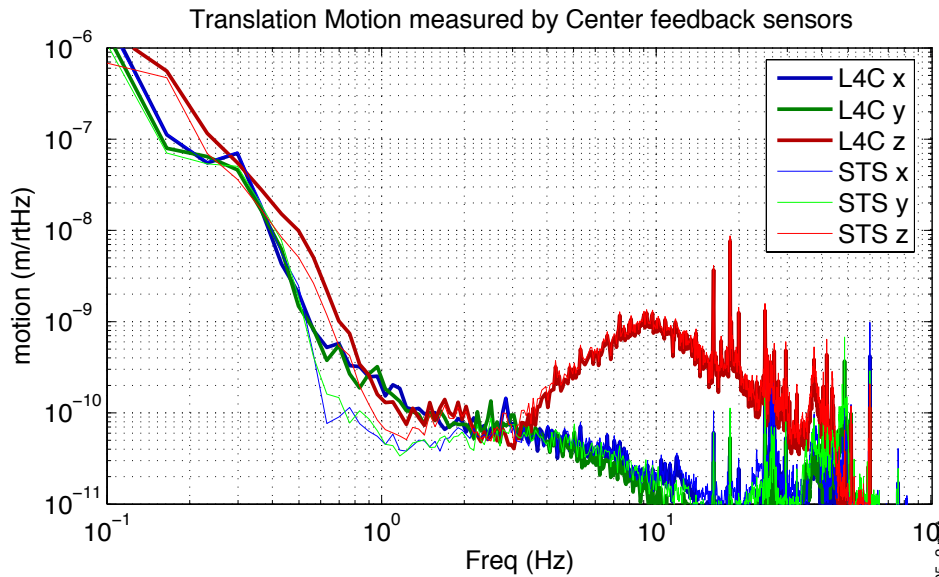

generated by process_noise_031805_2d.m on 31-Mar-2005; data from sensor_noise_031805_2.m

generated by process_noise_031805_2d.m on 31-Mar-2005; data from sensor_noise_031805_2.m

Conclusions

1. We can achieve an isolation factor of 100 at 1 Hz using only feedback. This is experimental validation of the isolation technique planned for Advanced LIGO.
2. But, we still have work to do...

Blend for stage 1 Z

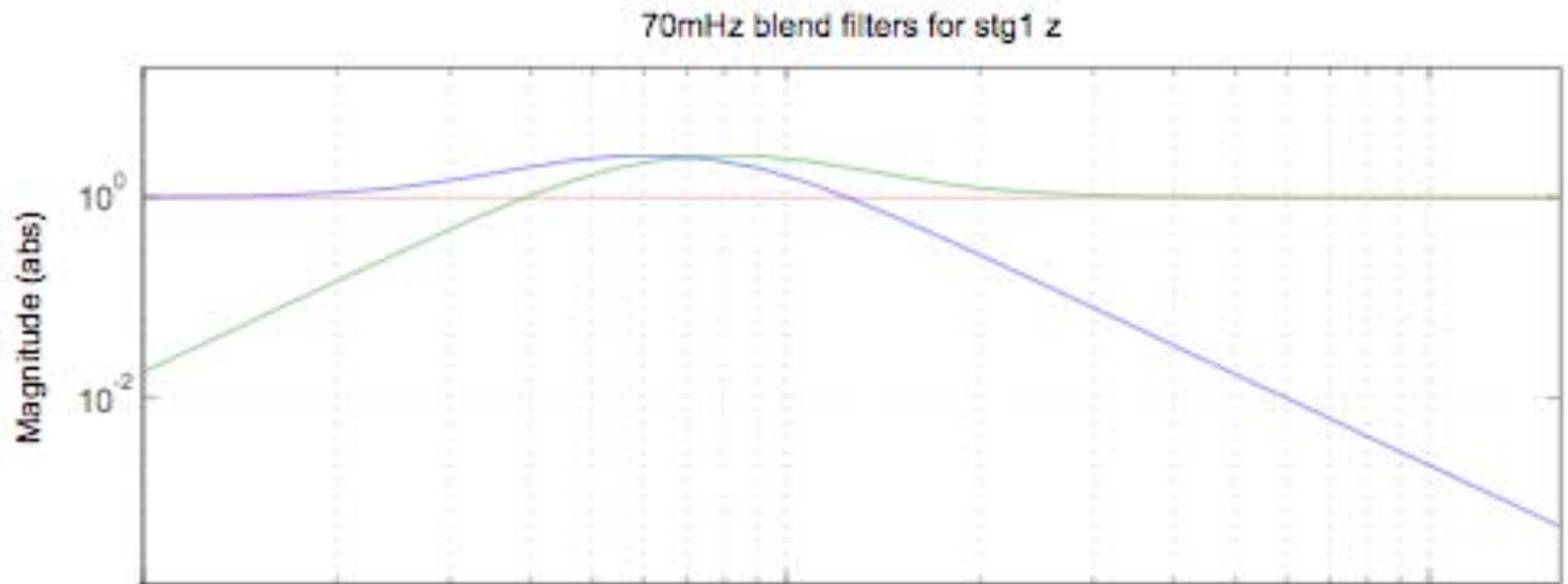

Possible Blend Filter for Stage 1

