



Flat-Top Beam Profile Cavity Prototype

**J. Agresti, E. D' Ambrosio, R. DeSalvo, J.M. Mackowsky,
M. Mantovani, A. Remillieux, B. Simoni, P. Willems**



7/23/2004



LIGO G040306-00-R



Motivations for a flat-top beam:

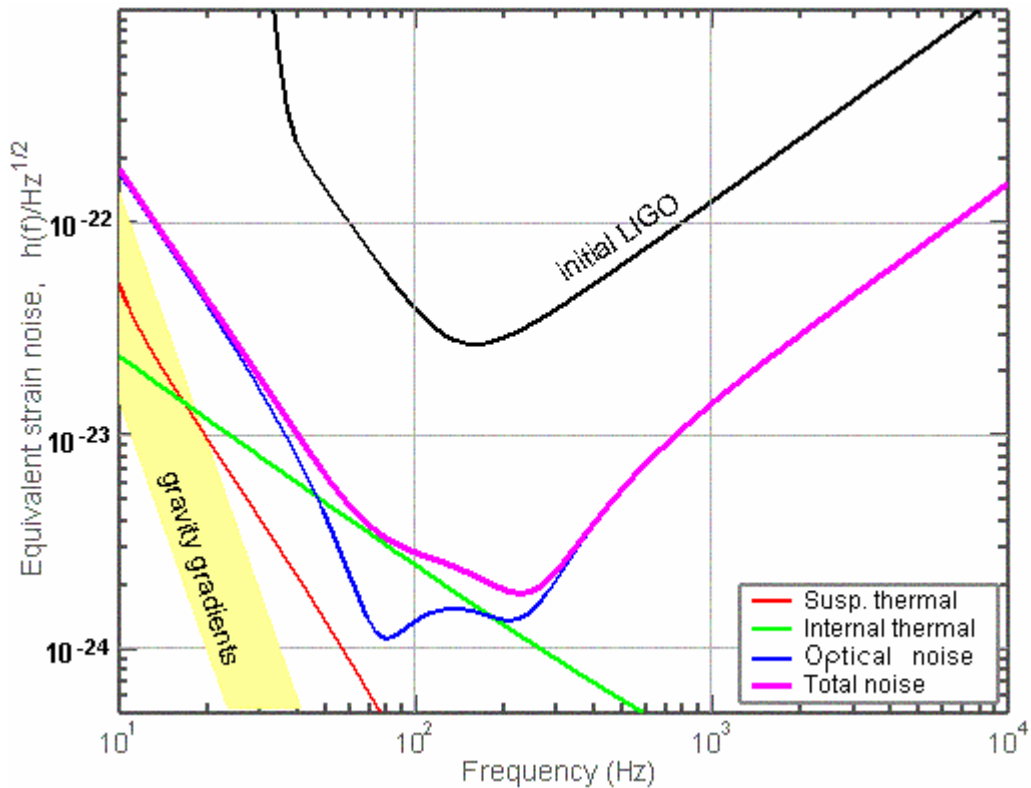

Advanced-Ligo sensitivity
(Sapphire Mirror Substrates)
Dominated by test-masses
thermoelastic and coating
thermal noises.



Can we reduce the influence
of thermal noise on the
sensitivity of the
interferometer?

Thermoelastic Noise:

Created by stochastic flow of heat within the test mass



Fluctuating hot spots and cold spots inside the mirror



Expansion in the hot spots and contraction in the cold spots creating fluctuating bumps and valleys on the mirror's surface

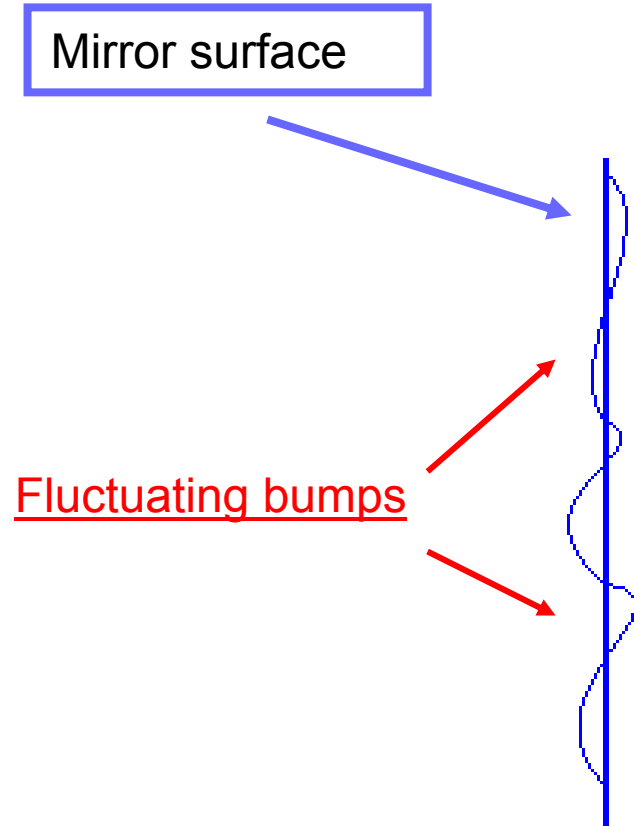

Interferometer output: proportional to the test mass average surface position, sampled according to the beam's intensity profile.

Gaussian beam

$$S_h^{TE} \propto \frac{1}{\sqrt{r_0^3}}$$

r_0 **As large as possible**
(within diffraction loss
constraint).

The sampling
distribution changes
rapidly following the
beam power profile

**Larger-radius, flat-top
beam will better average
over the mirror surface.**

Mirror surface

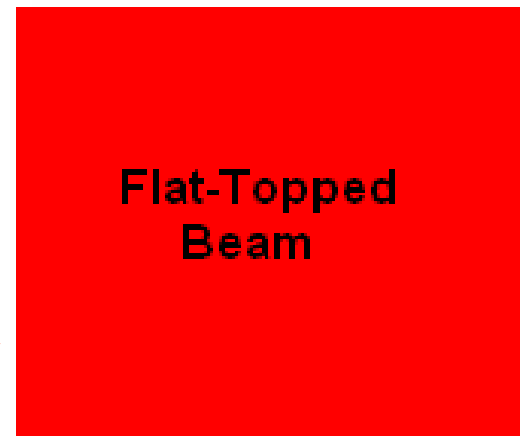

Diffraction prevents the creation of a beam with a rectangular power profile...but we can build a nearly optimal flat-top beam:

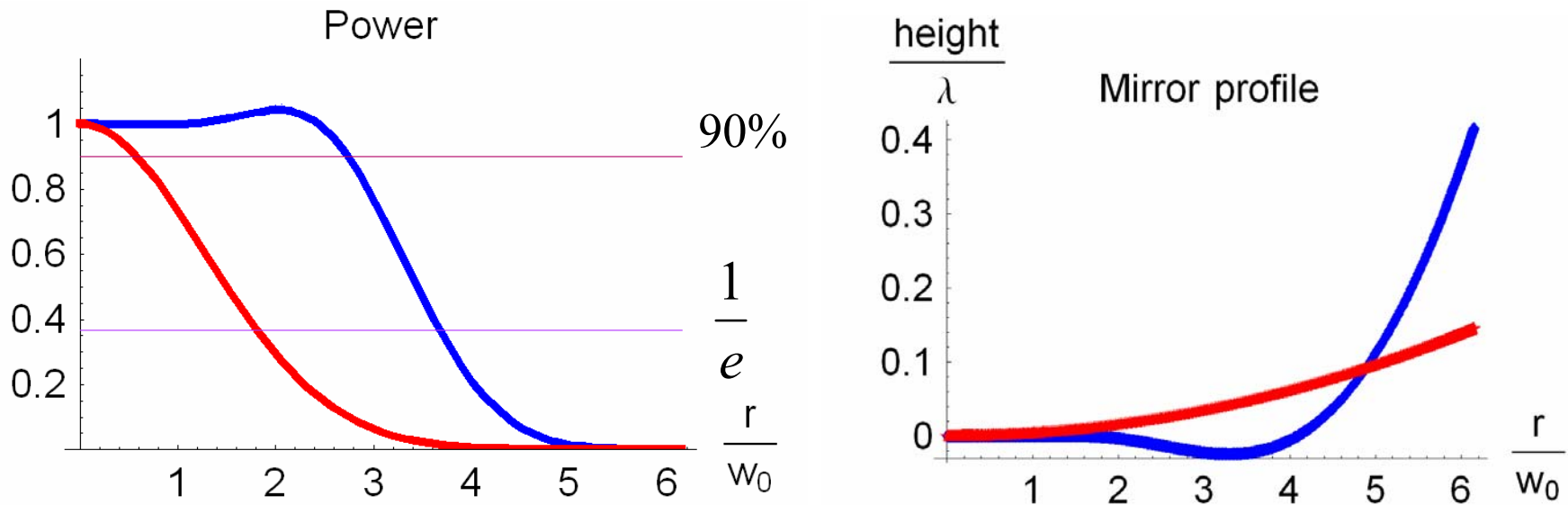
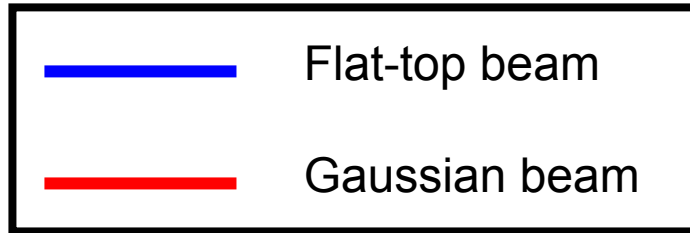

•The mirror shapes match the phase front of the beams.

Comparison between the two beams

(Same diffraction losses)

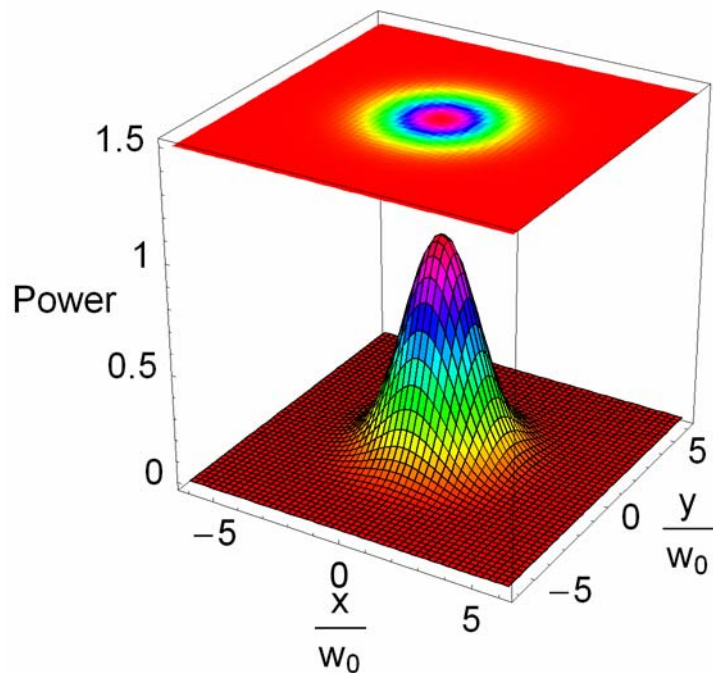

$$S(r_0) \approx 0.09 S_{mir}$$

$$S(r_{90\%}) \approx 0.01 S_{mir}$$

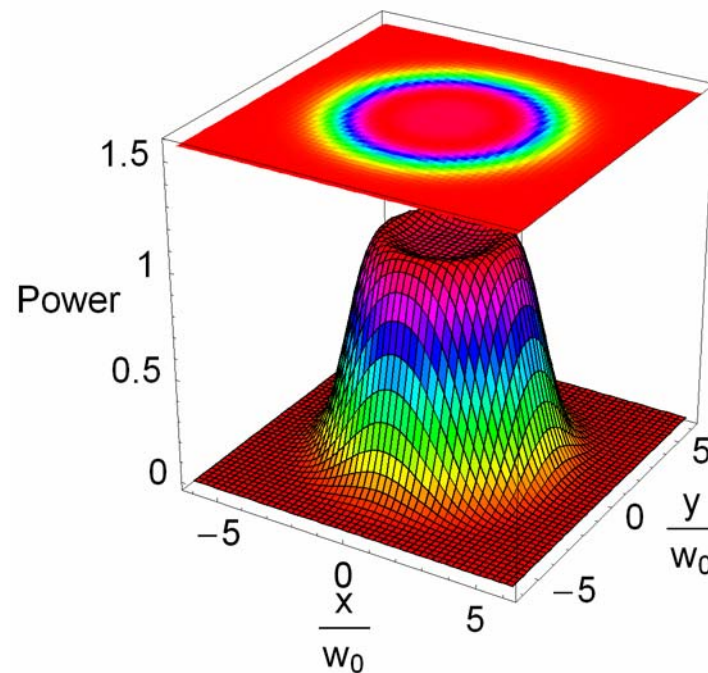

$$S(r_0) \approx 0.36 S_{mir} \quad R = 4$$

$$S(r_{90\%}) \approx 0.20 S_{mir} \quad R = 20$$

Indicative thermal noise suppression trends

$$S_h \propto \frac{1}{\sqrt{r_0^3}} \quad \text{Substrate thermoelastic noise}$$

$$S_h \propto \frac{1}{r_0} \quad \text{Coating thermal noise}$$

$$S_h \propto \frac{1}{\sqrt{r_0}} \quad \text{Substrate thermal noise}$$

Exact results require accurate information on material properties (Q-factors)

Expected gain in sensitivity ~ 3

Goals of our project:



Build a small optical cavity to verify the behaviour of the flat top beams and gain experience in their generation and control.

We will investigate the **modes structure** and characterize the **sensitivity to perturbations** when non Gaussian beams are supported inside the cavity.

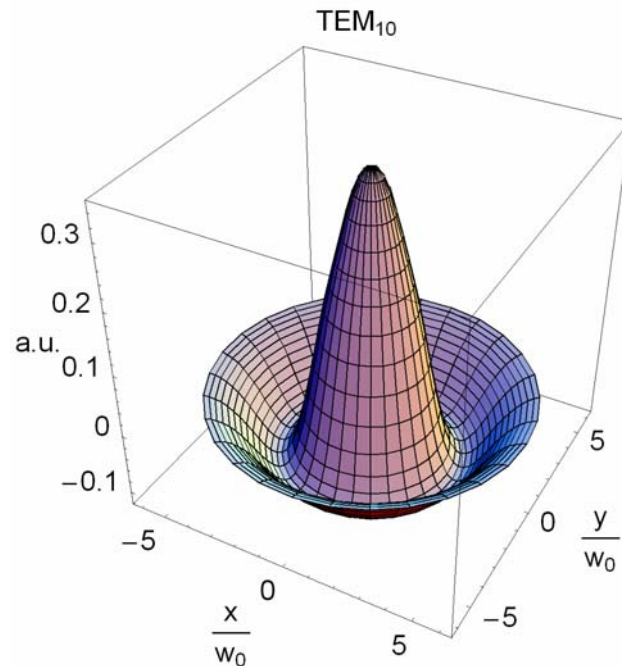
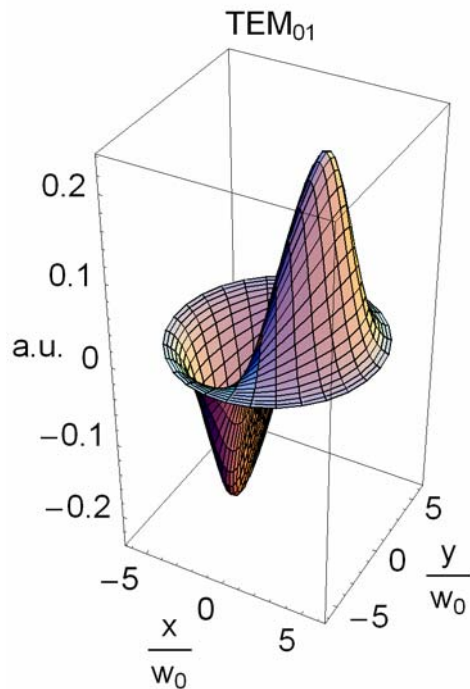
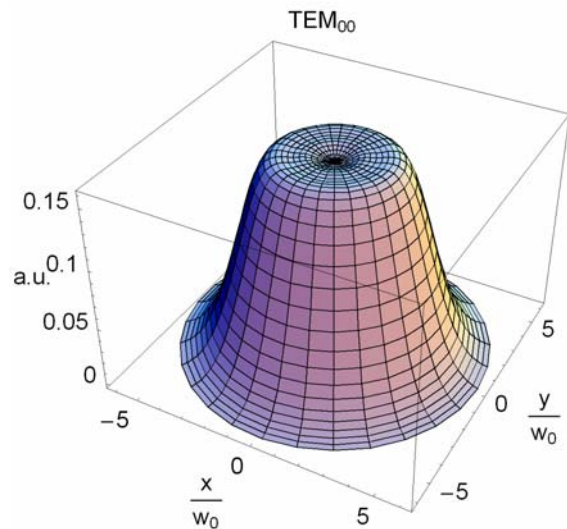

Misalignment produces coupling between modes

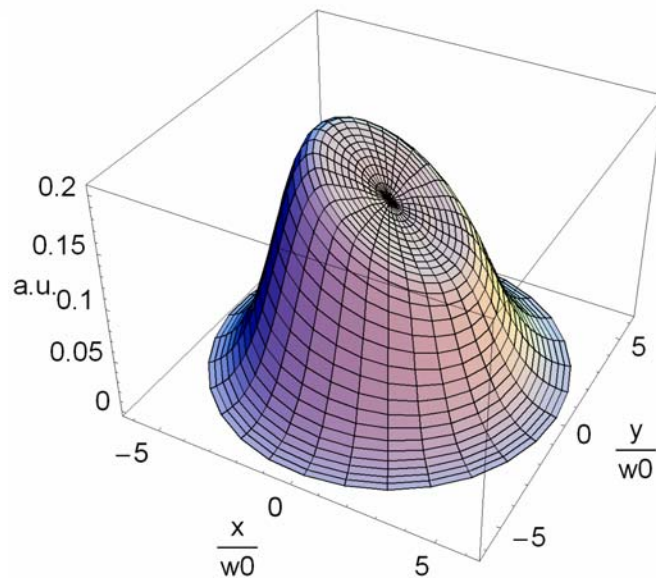

Design of the test cavity : Rigid cavity suspended under vacuum

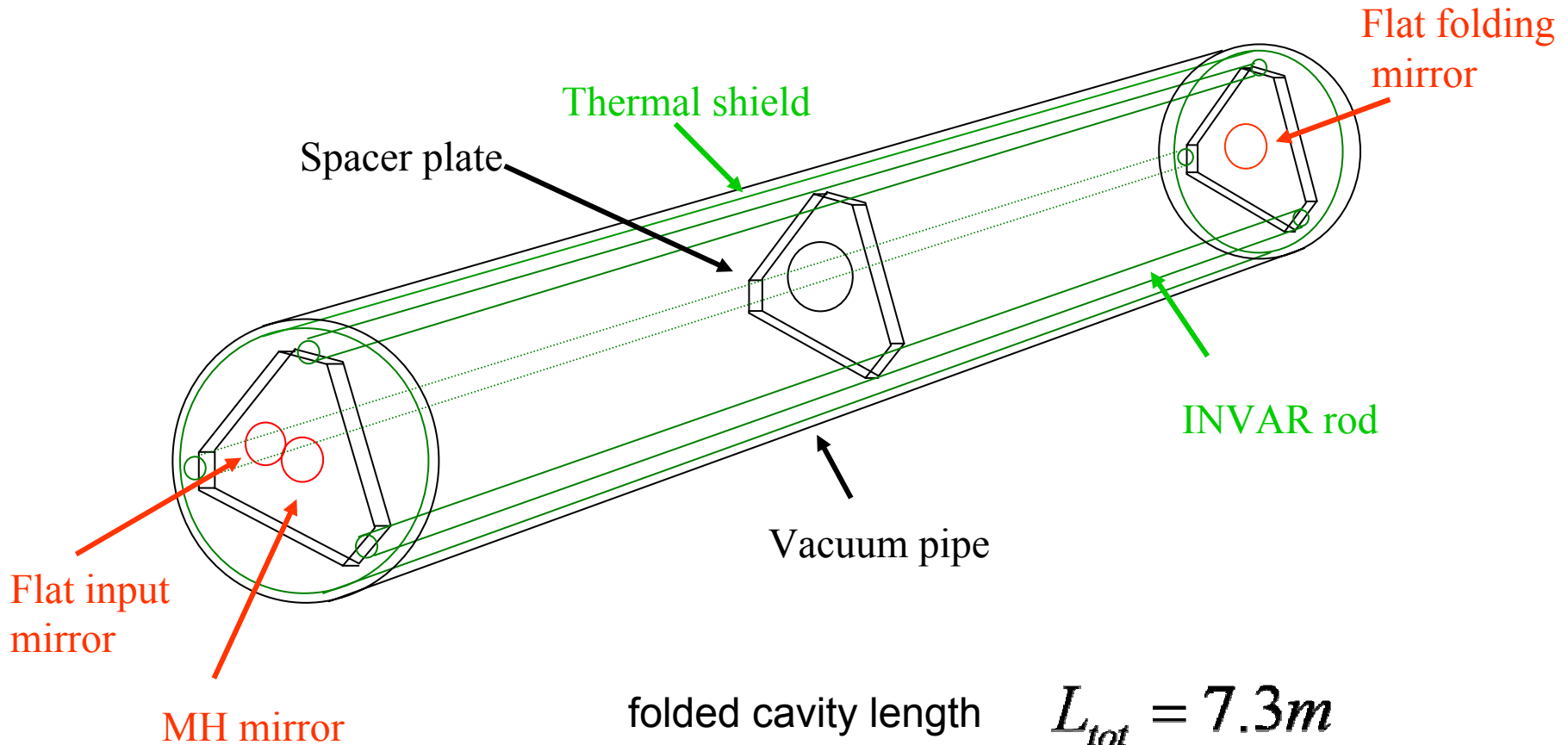

$$L_{tot} = 7.3m$$

$$W_{tot} \approx 87Kg$$

Optical and mechanical design:

- Injection Gaussian beam designed to optimally couple to the cavity.
- Required finesse $F = 100$ to suppress Gaussian remnants in the cavity.

Length stability: ~ 5 nm

- INVAR rods (low thermal expansion coefficient).
- Stabilized temperature.
- Vacuum eliminates atmospheric fluctuations of optical length.
- Ground vibrations can excite resonance in our interferometer structure: suspension from wires and Geometrical-Anti-Spring blades.

Mirror's size constrained by beam shape and diffraction losses

Our Mexican Hat mirror:

Diameter set by diffraction losses and technical difficulties...

Diffraction losses of ~ 1 ppm requires mirror's radius >1 cm.

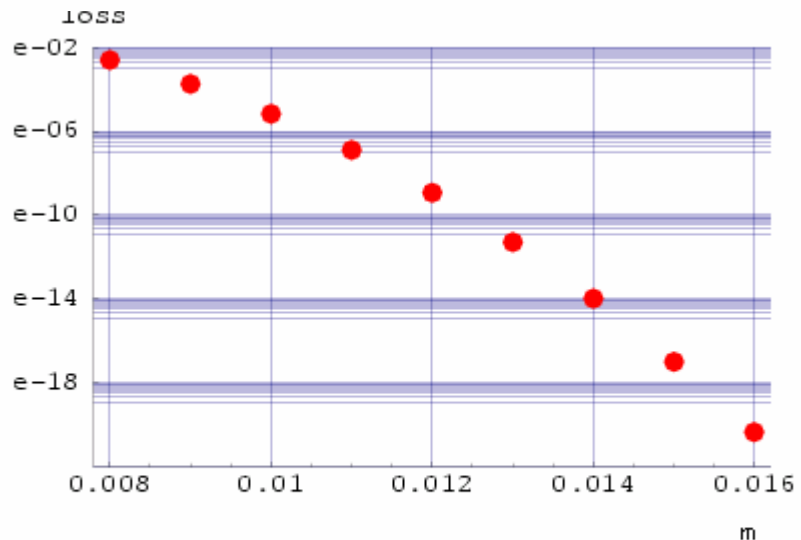
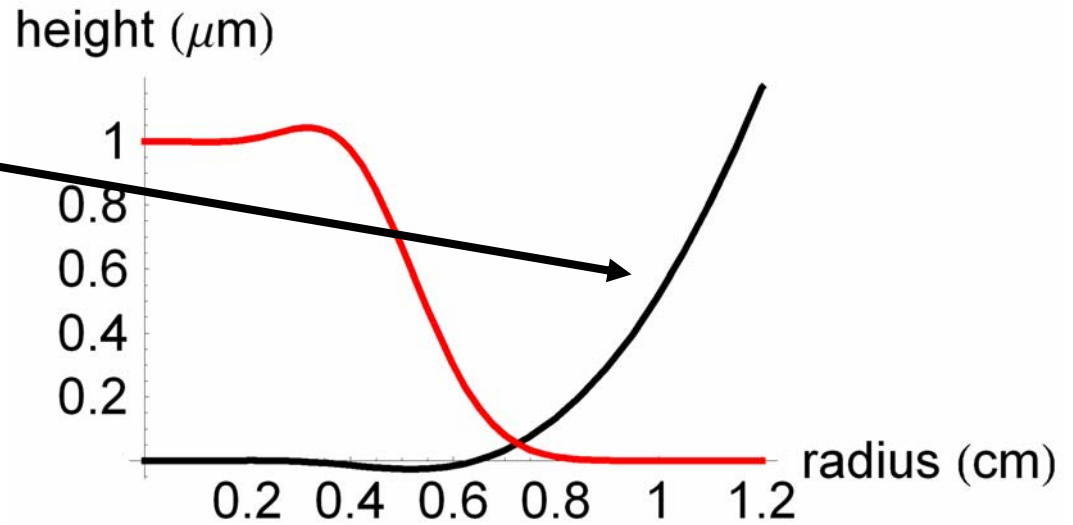

LMA's Technique to build Mexican Hat mirrors

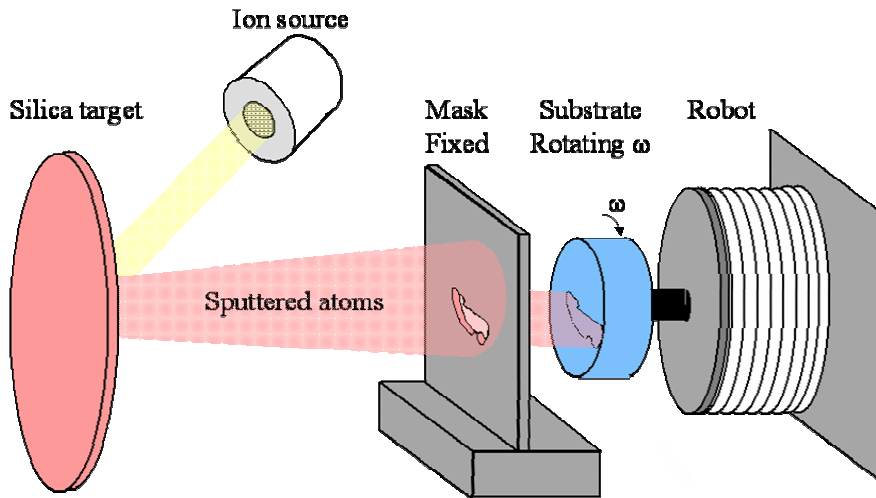

- Rough Shape Deposition:
- Coating the desired Mexican Hat profile using a pre-shaped mask
- Achievable precision $\sim 60\text{nm}$ Peak to Valley

- Corrective coating:
- Measurement of the achieved shape
- Coating thickness controlled with a precision $< 10\text{ nm}$.

**Maximum slope
~ 500nm/mm**

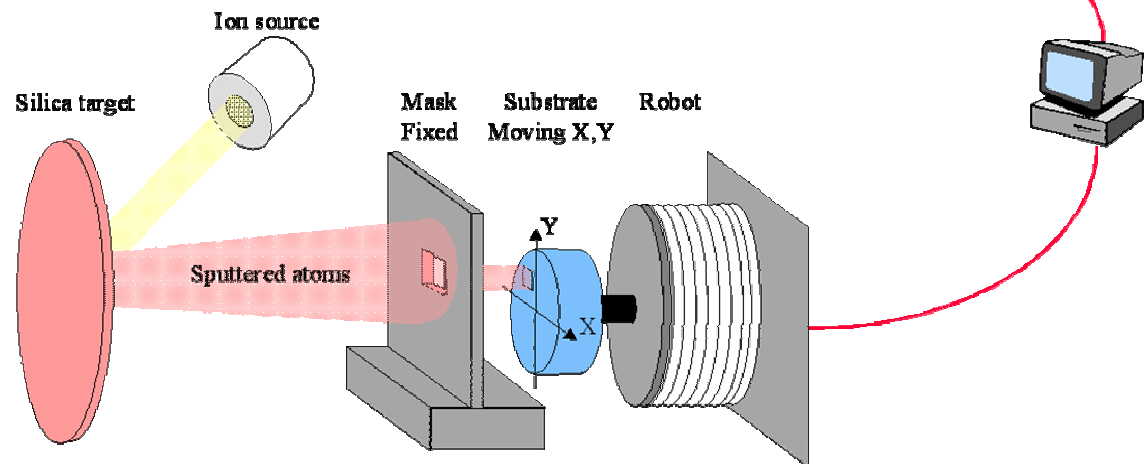

Cavity Suspensions

V ~ 0.6 Hz
H ~ 1 Hz

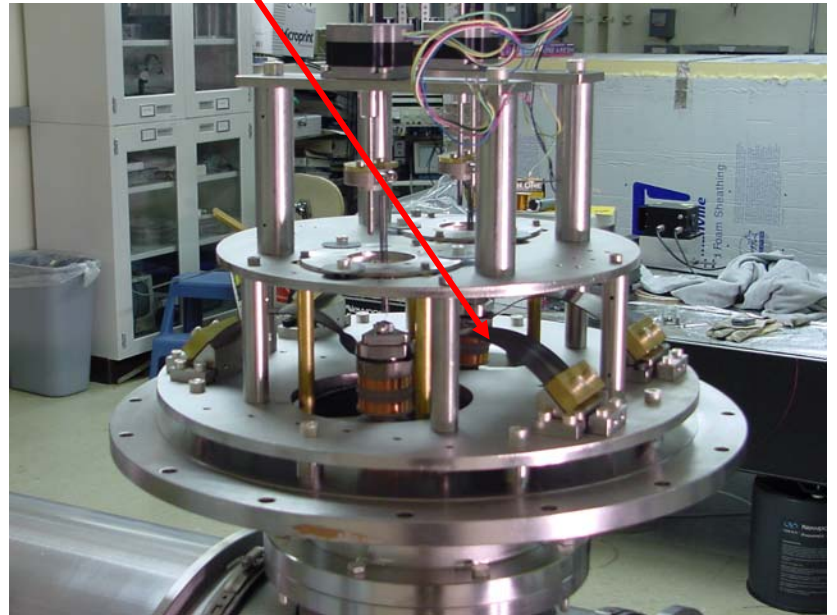
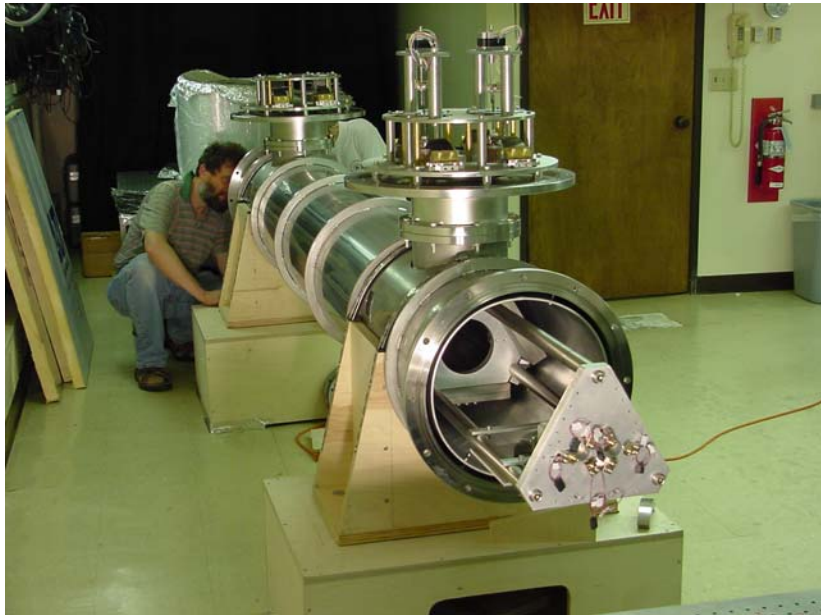
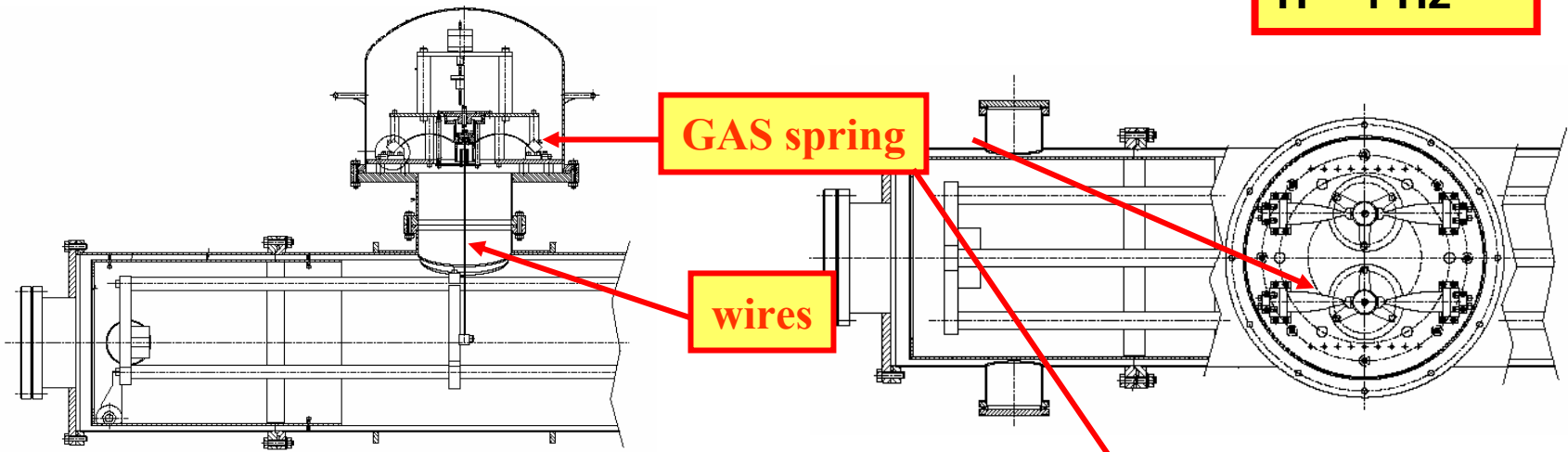

7/23/2004

LIGO G040306-00-R

Cavity Vacuum & Thermal Shield

Suspension view

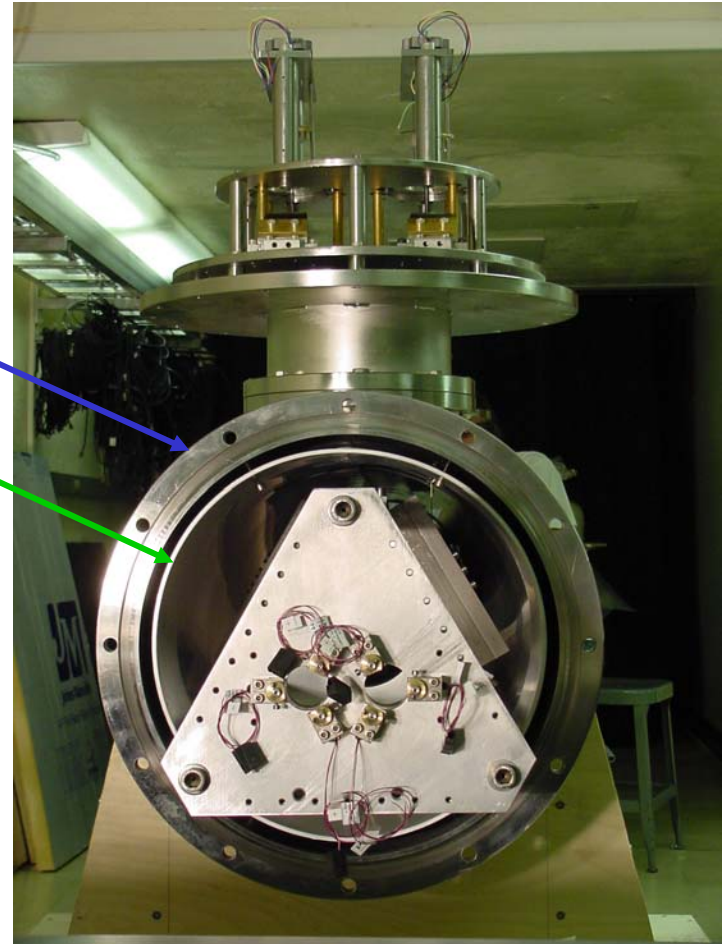
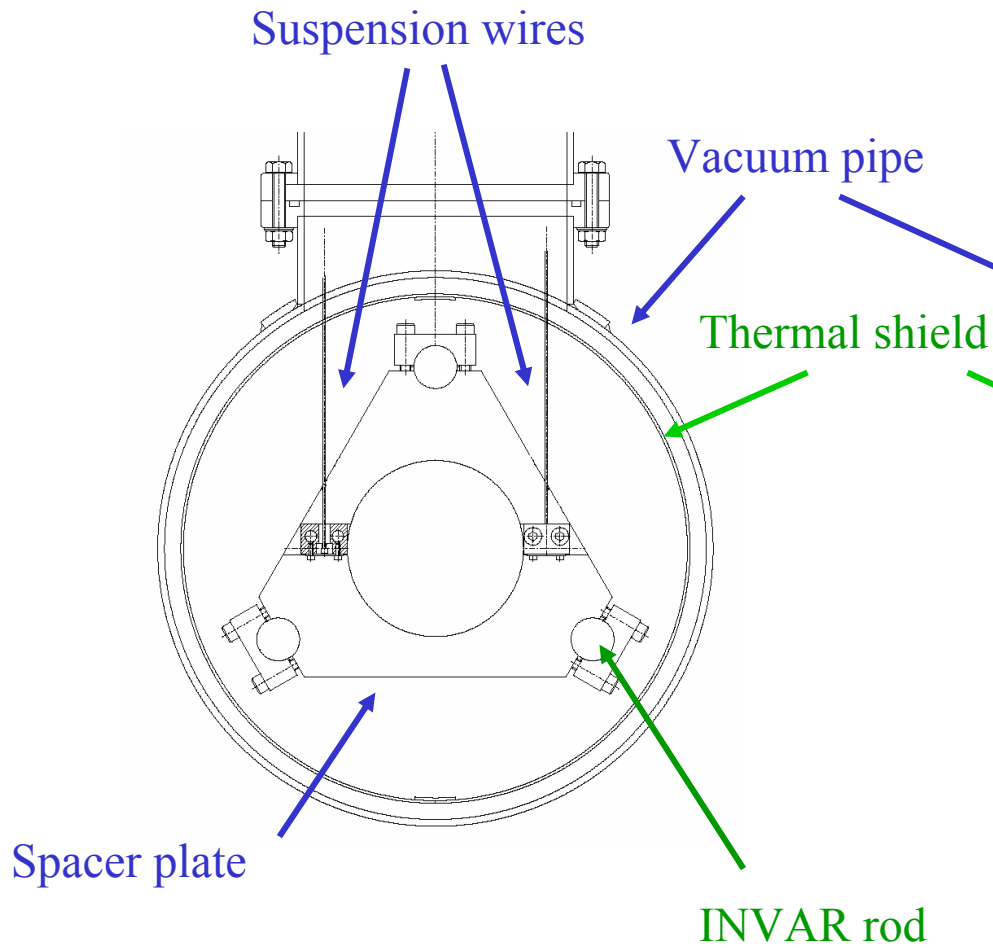

Suspension at work!

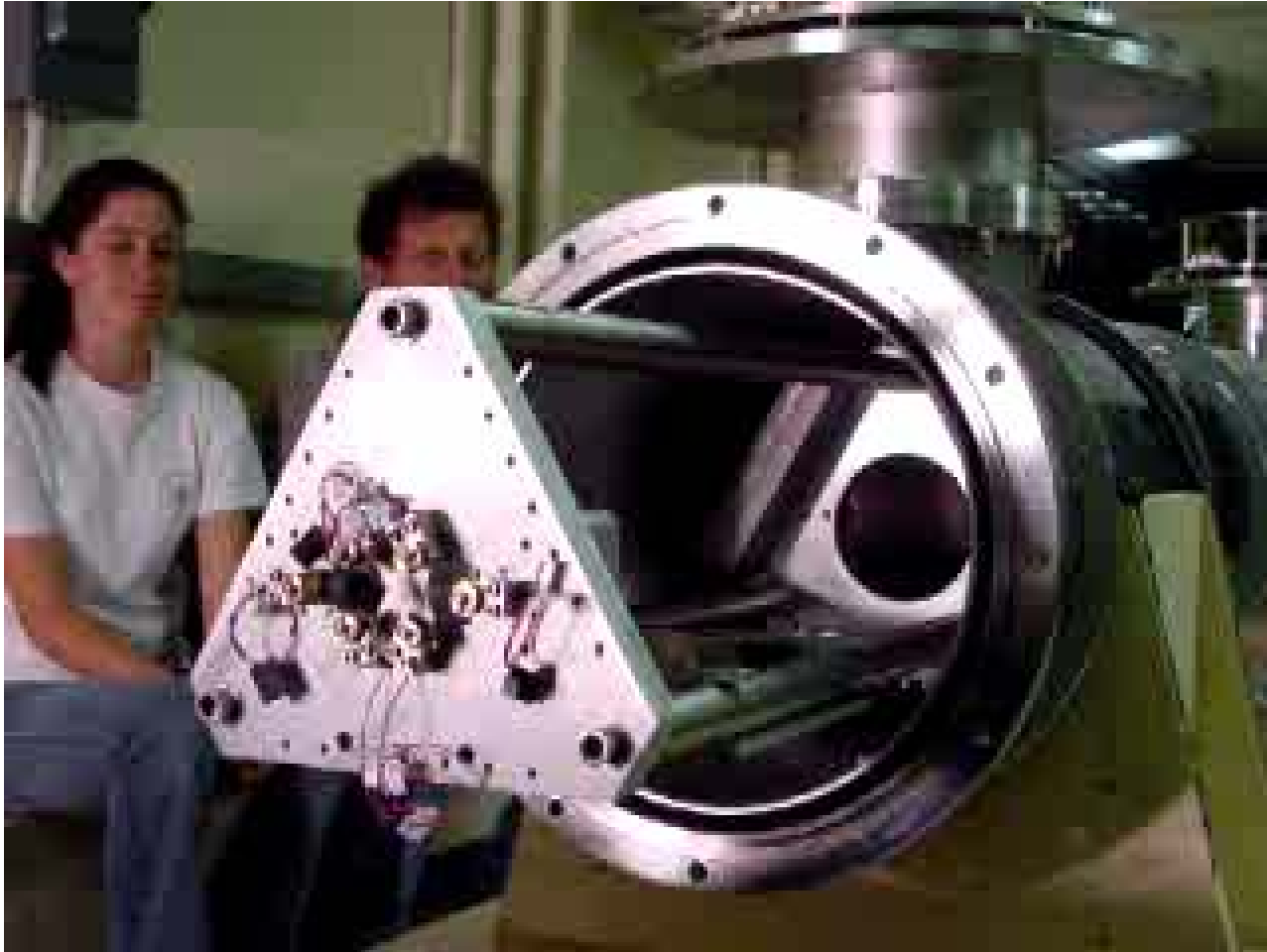

7/23/2004

LIGO G040306-00-R

16

Schedule for the future

- Complete building the cavity including the optics and the electronics
- Lock the cavity with spherical mirror (test the apparatus)
- Switch to Mexican-Hat mirror as soon as available
- Characterization of Flat-top beam modes and misalignment effects

Next possible developments

Flat topped beam inside a nearly-concentric cavity: same power distribution over the mirrors but less sensitive to misalignment.

Overcome the technical limitation on the slope of the coating...not impossible.