

# RF readout scheme to overcome the SQL

**Kentaro Somiya**  
**LIGO-G040228-00-Z**

**Feb. 16<sup>th</sup> , 2004**  
**Aspen Meeting**

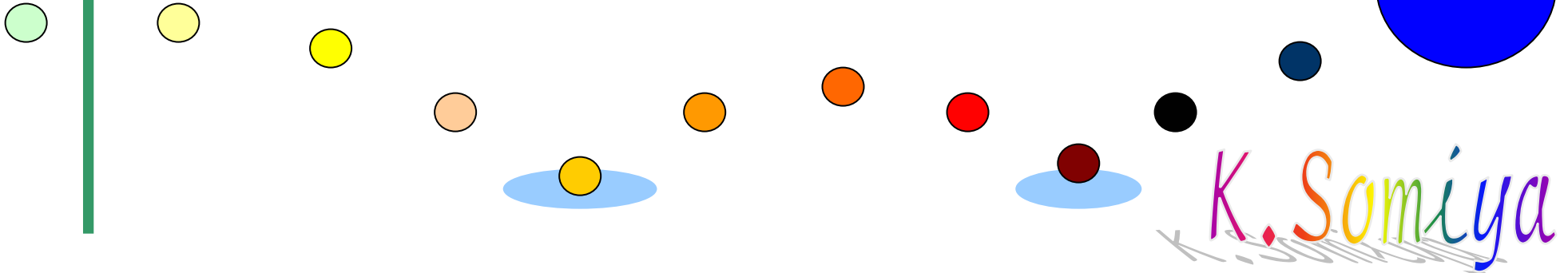

# Readout scheme

**DC**

or

**RF**

Commonly used in QND study

Commonly used in GW detectors

Only one readout phase

Many readout phase can be used

(shown later)

No additional quantum noise

Additional quantum noise from  
RF region



This noise can be hopefully removed by RF input squeezing, and the sensitivity can be better than that with DC readout !

# Contents

- **Short review of quantum noise**
- **Input squeezing and homodyne detection**
- **RF readout scheme (unbalanced sideband detection)**
- **RF input squeezing**
- **Multi-phase detection**
- **Summary and Discussion**

# Review of quantum noise

**Particles**  
**photon number**

<Property>  
<Fluctuation>

**Waves**  
**light phase**

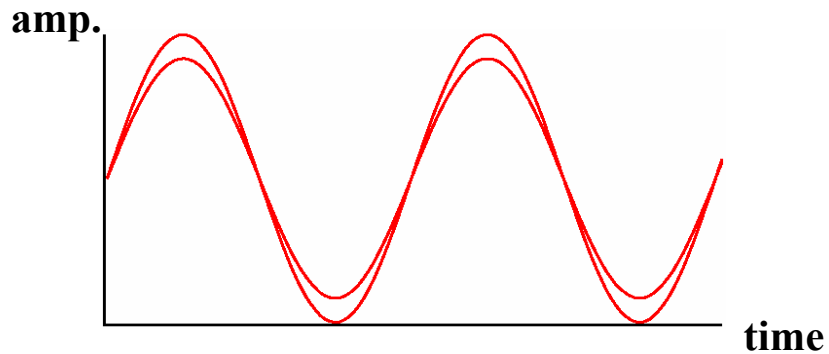

**Radiation pressure noise**

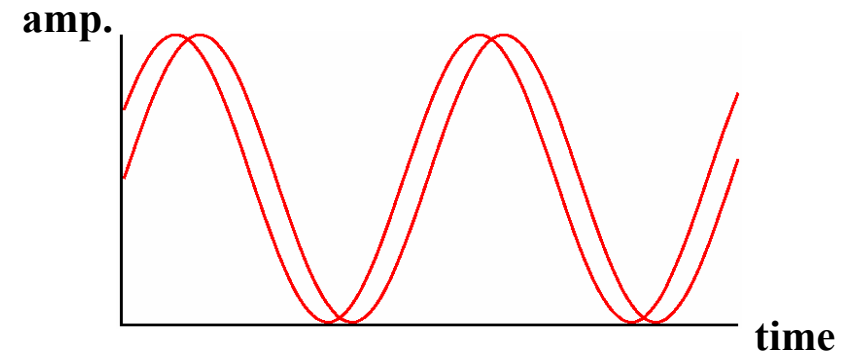

**Shot noise**

**Both noise sources behave as sidebands to the classical light with or without  $\pi$  phase shift.**

# Vacuum fluctuation as SB

Fourier space:  
relative phase to the carrier light

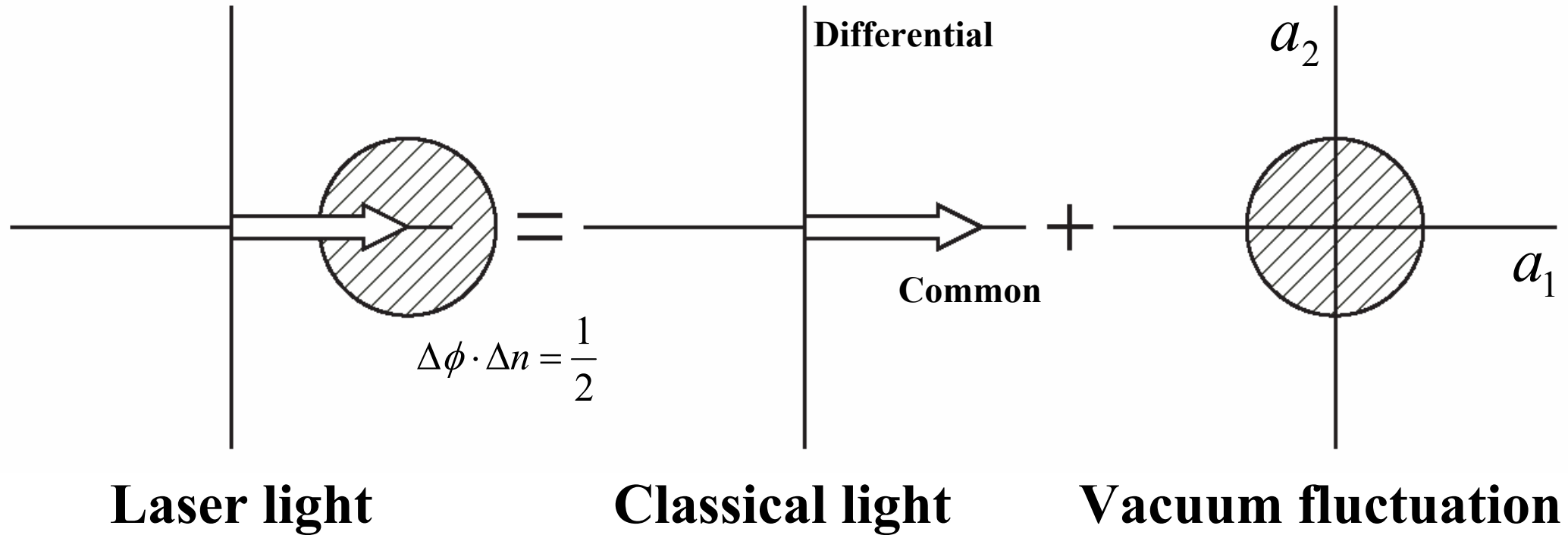

Where does vacuum come from?

# Vacuum fluctuation from DP

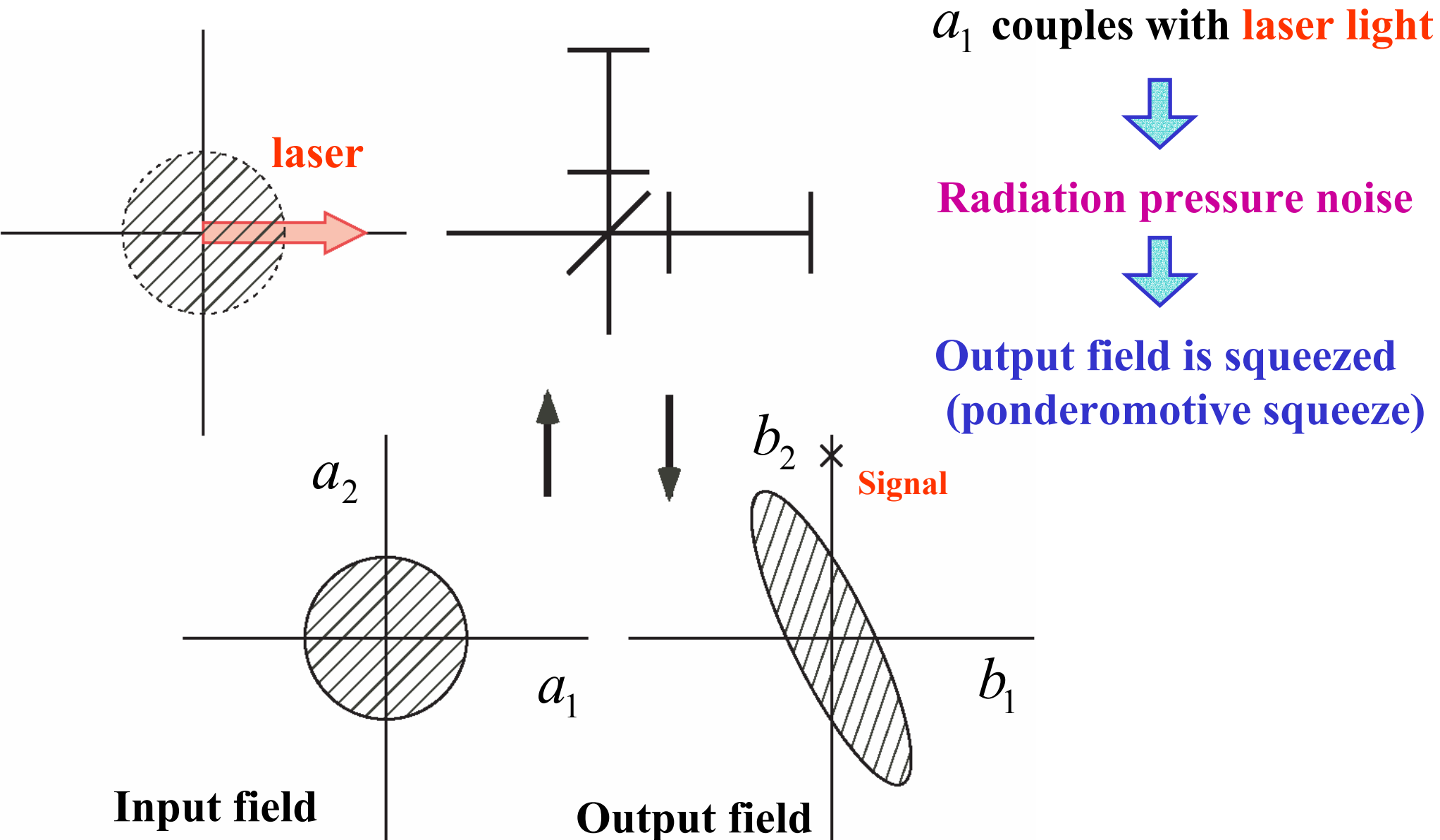

# Standard Quantum Limit

Conventional

readout phase

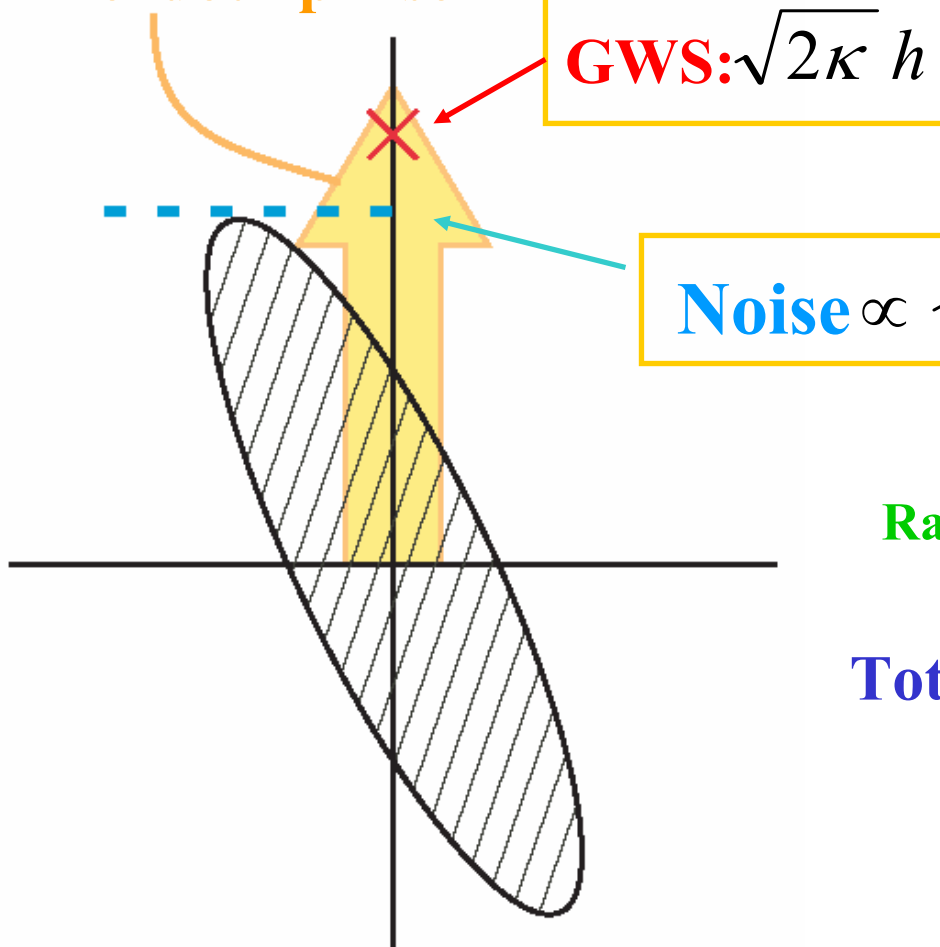

**GWS:**  $\sqrt{2\kappa} h$

**Noise**  $\propto \sqrt{\kappa^2 + 1}$

Shot noise

Radiation pressure noise

**Total quantum noise level**

$$h_n = h_{SQL} \sqrt{\frac{\kappa^2 + 1}{2\kappa}} \leq h_{SQL}$$

$$\kappa \equiv \frac{(I_0 / I_{SQL}) 2\gamma^4}{\Omega^2 (\Omega^2 + \gamma^2)}$$

represents the power in the cavity.

( $\Omega$ : GW freq. ,  $\gamma$ : cavity pole)

**SQL is defined including this ponderomotive squeezing.**

# How to beat the SQL ? $\sim$ QND techniques

## (1) Input Squeezing

With non-linear optics

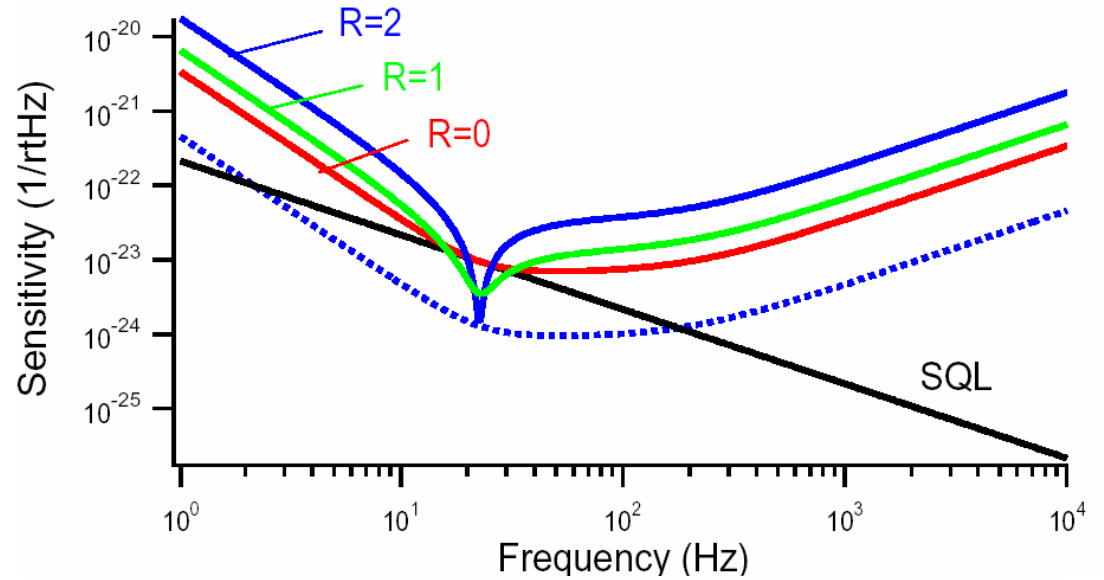

## (2) Homodyne Detection

Changing readout phase

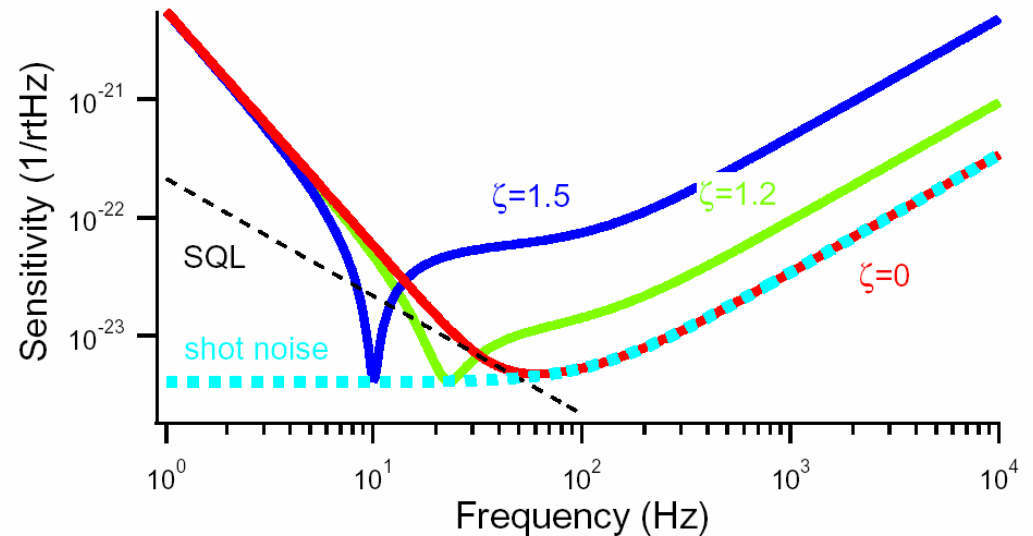



# Input Squeezing

Nonlinear Optics

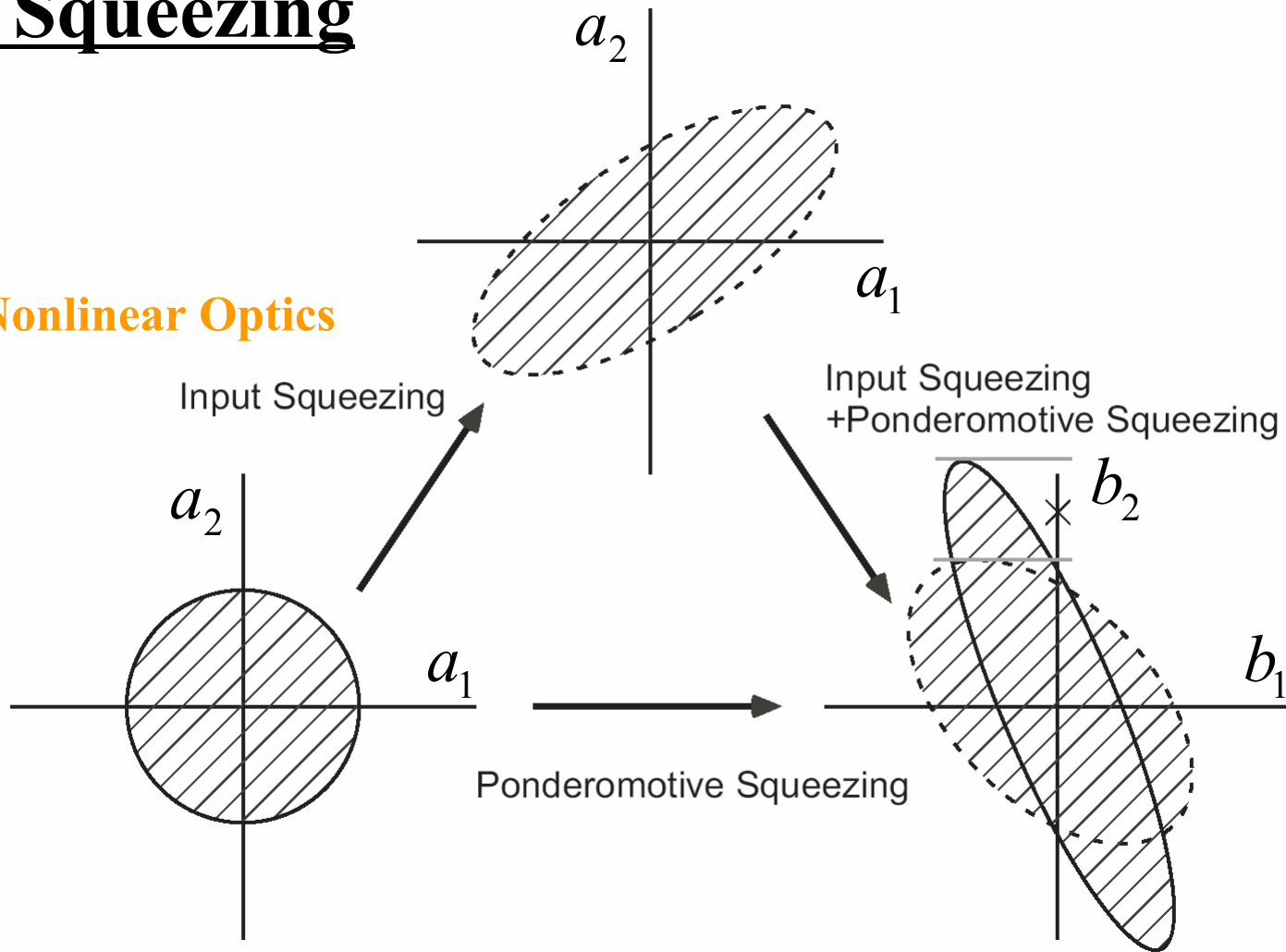

**Reshape the ellipse of ponderomotive squeezing!**

# Input Squeezing Experiment in ANU

(McKenzie *et al*, Phys. Rev. Let. Vol.88 2002)

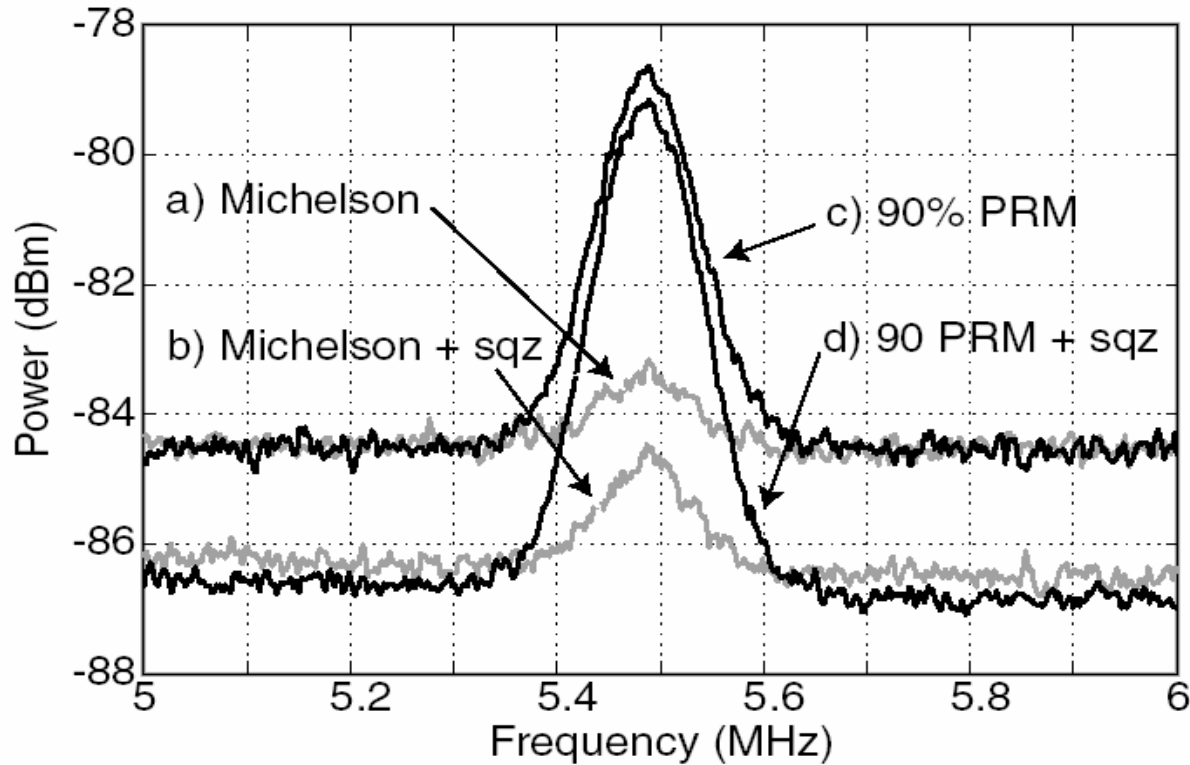

- **Successful squeezing by 7dB ( $R \sim 2$ ) in mega-hertz region**
- **Need more time for squeezing at  $\sim 100$ Hz**

# Homodyne Detection

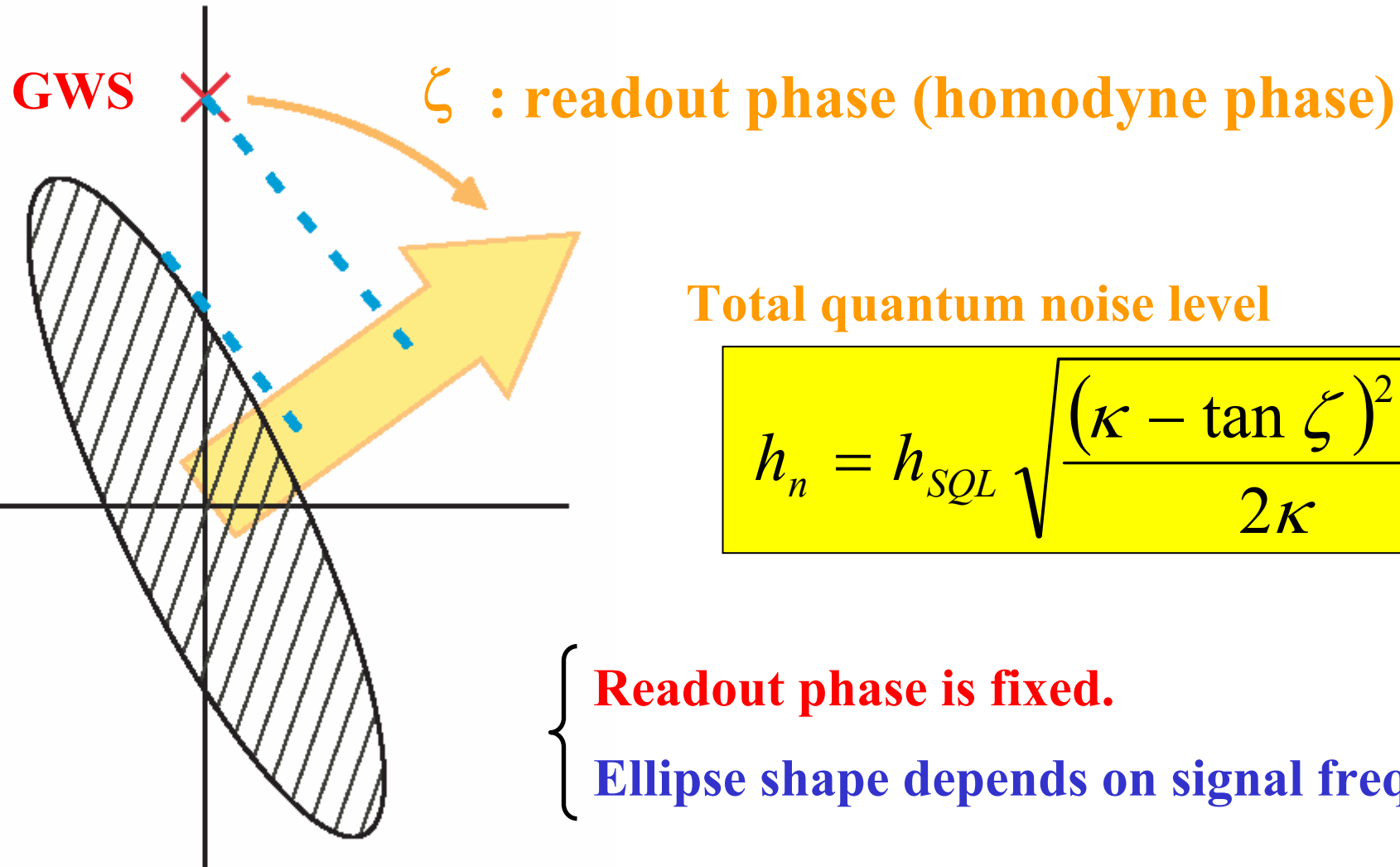

- Readout phase is fixed.**
  - Ellipse shape depends on signal freq.**
- QND at particular frequency.**

# Homodyne detection spectrum

$\zeta$  : readout phase

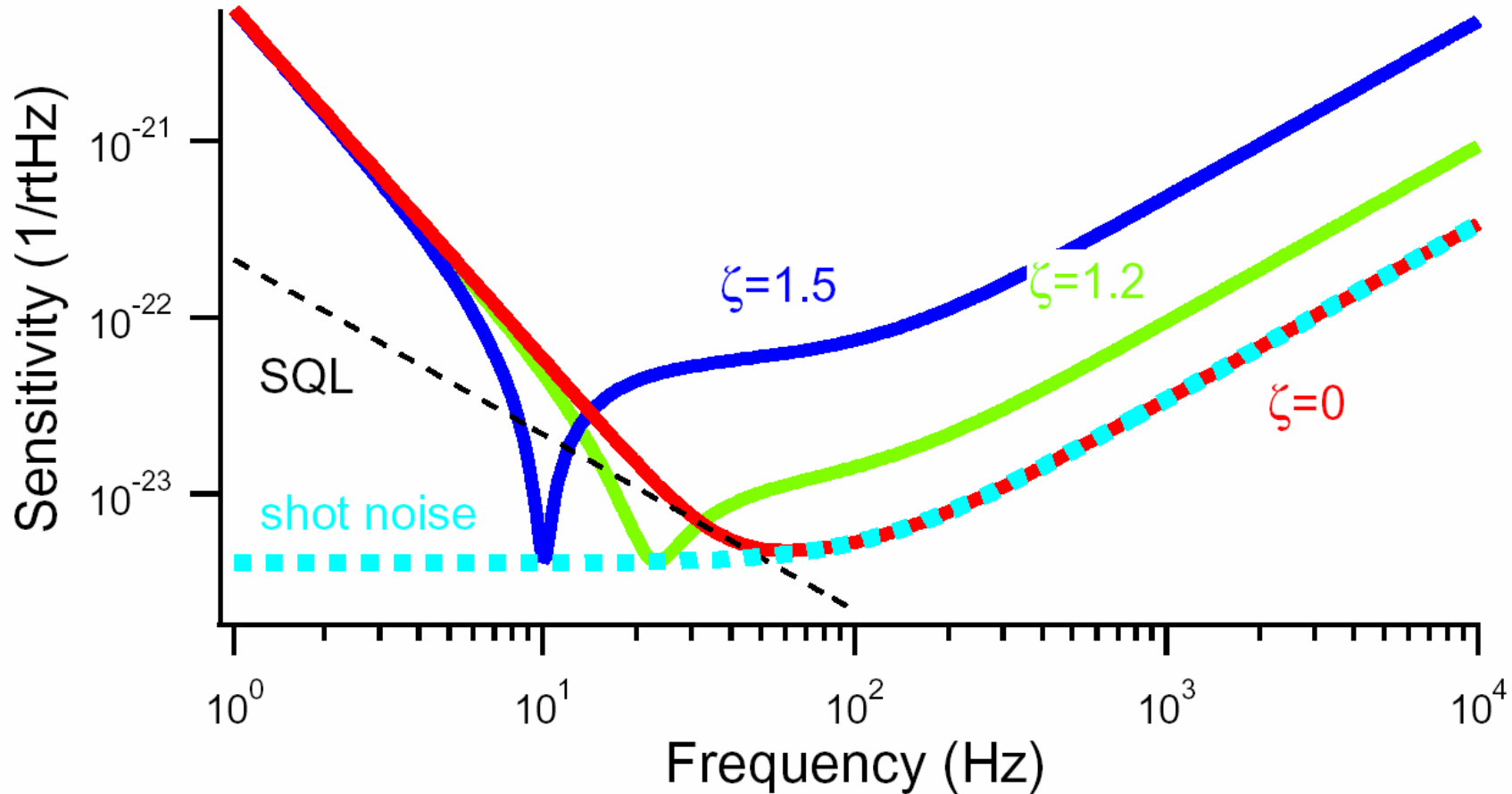

**No radiation pressure noise in narrow band.**

# Conventional way of homodyne detection

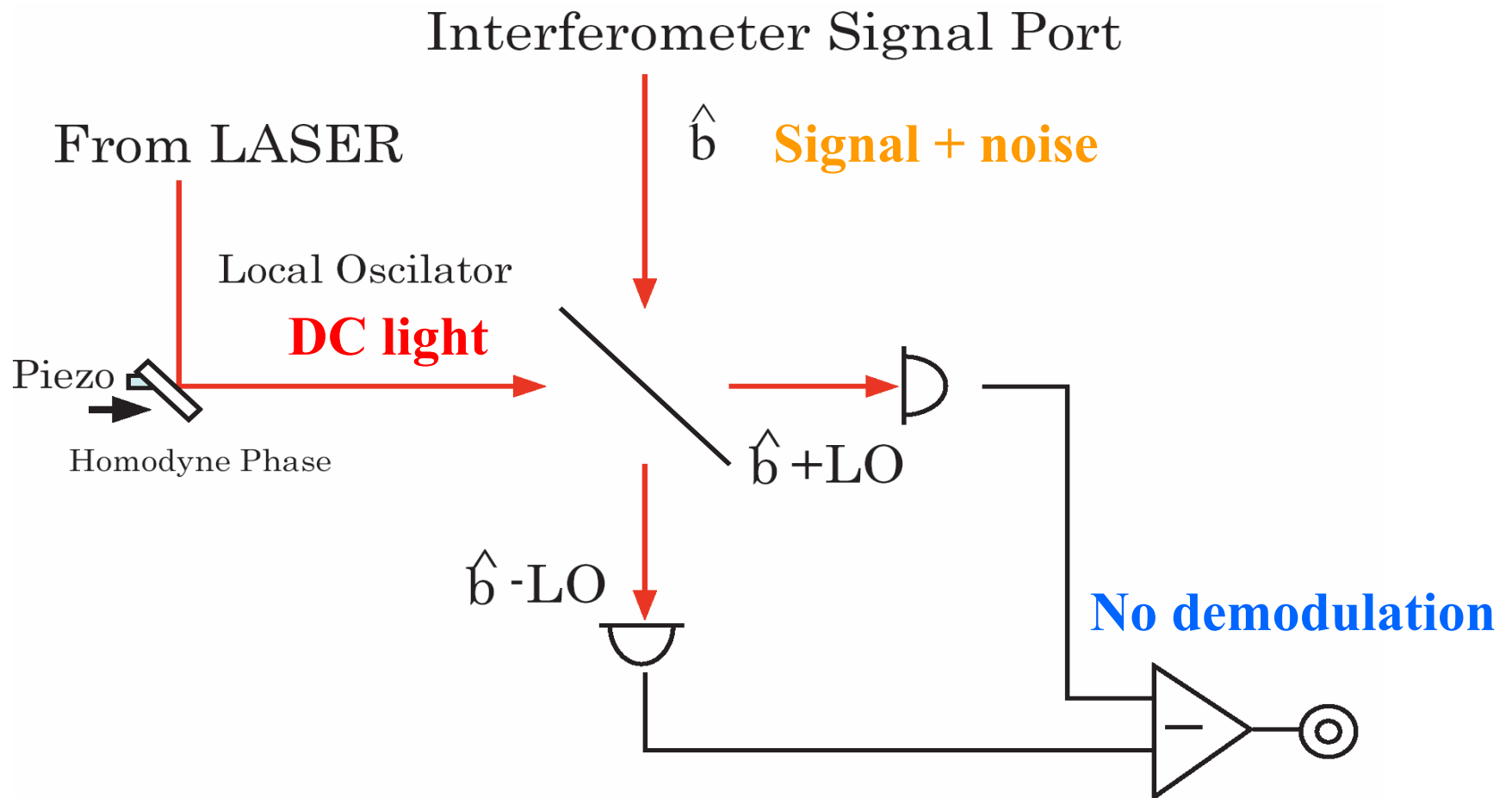

- **Additional beamsplitter would be troublesome.**
- **Direct coupling of AC noise might be a problem.**

# DC readout

Planned to be used for AdLIGO.

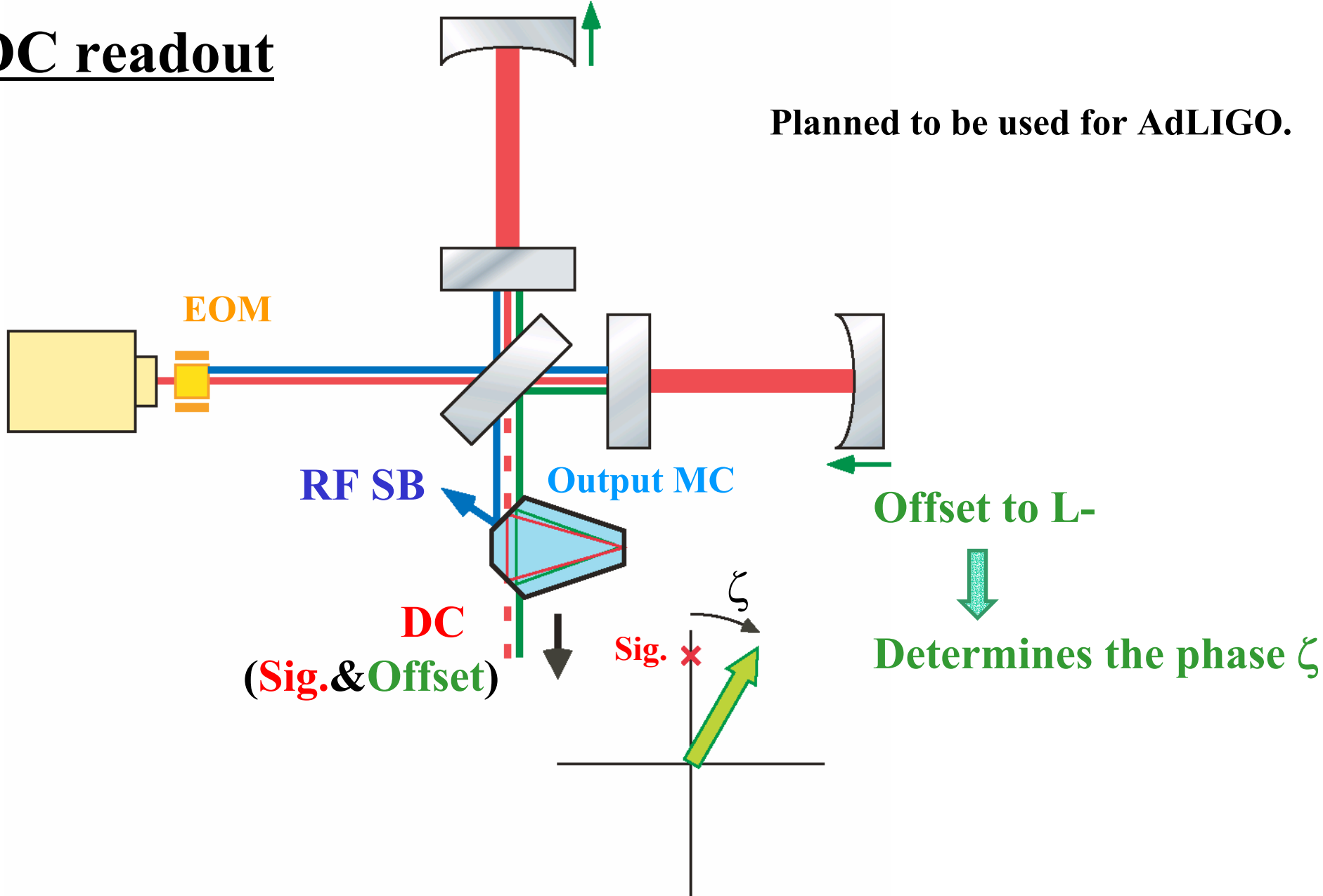

Several issues should be tested at Caltech 40m.

# Problem of these QND techniques

## 1) Input Squeezing

Only available at low frequencies so far.

## 2) Homodyne Detection, or DC readout Direct coupling of AC noise.

→ Isn't it possible to change the readout phase with conventional RF readout scheme?

# RF modulation-demodulation scheme

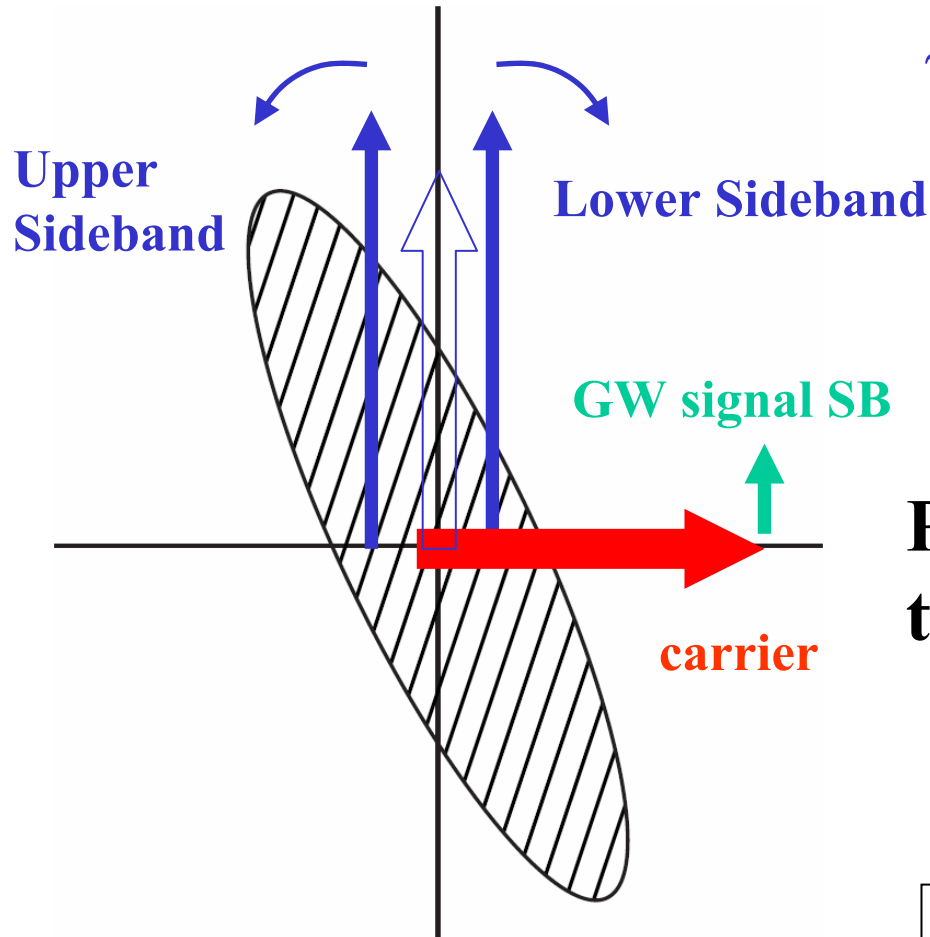

**Phase modulated SB is made of the upper and the lower sidebands.**



**Readout phase is fixed to zero.**



# What if there is only a single sideband ?

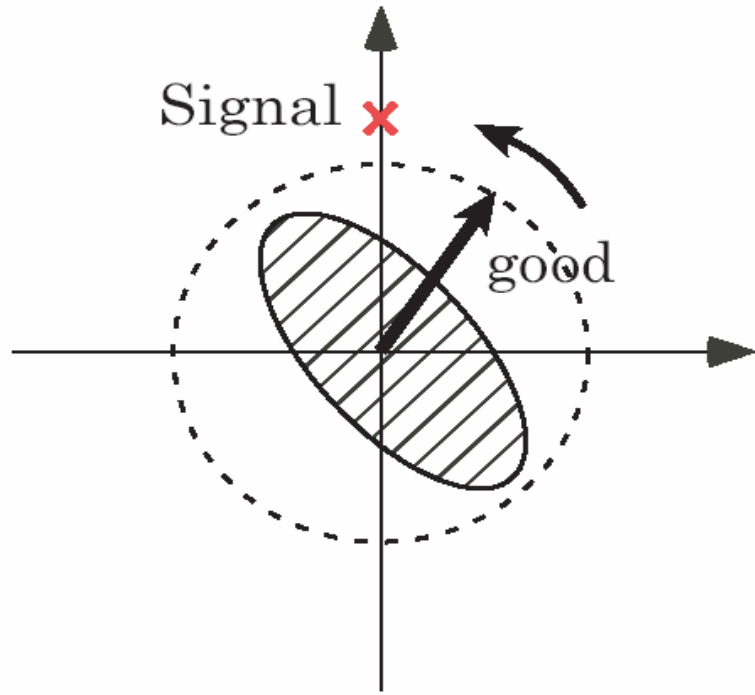

Single Sideband

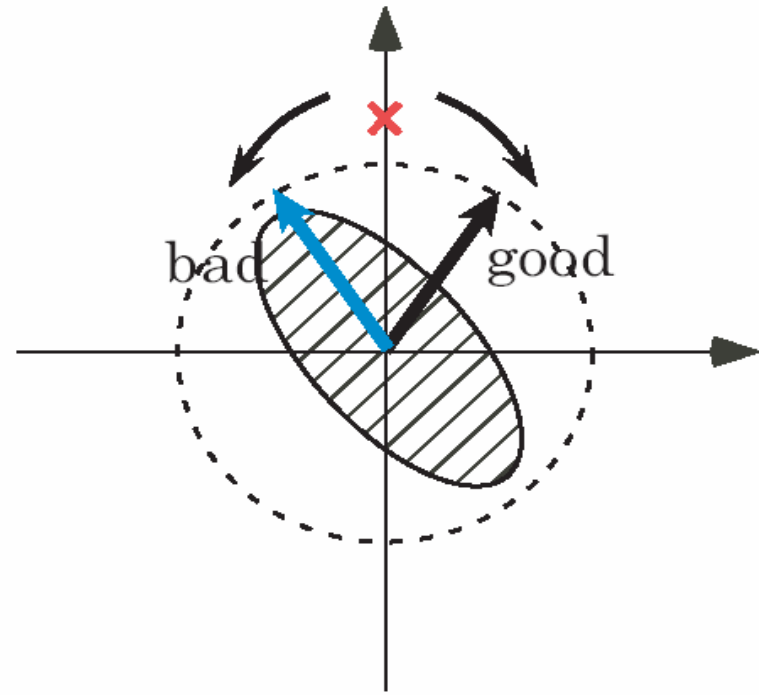

Dual Sidebands

→  
Calculated result

$$h_n = h_{SQL} \sqrt{\frac{(\kappa - \tan \zeta')^2 + 1}{2\kappa}}$$

( $\zeta'$ =demodulation phase)

**Readout phase can be chosen by demodulation phase.**

# Why demodulation phase ?

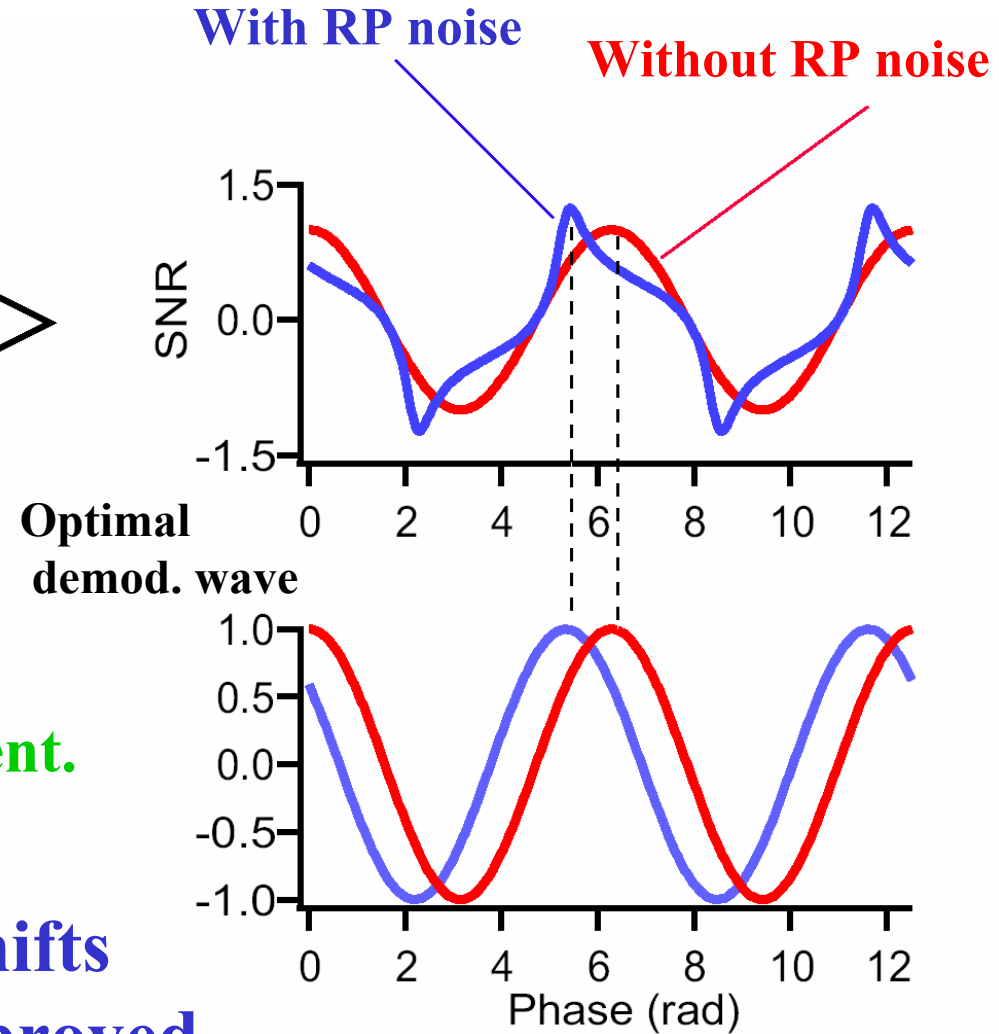
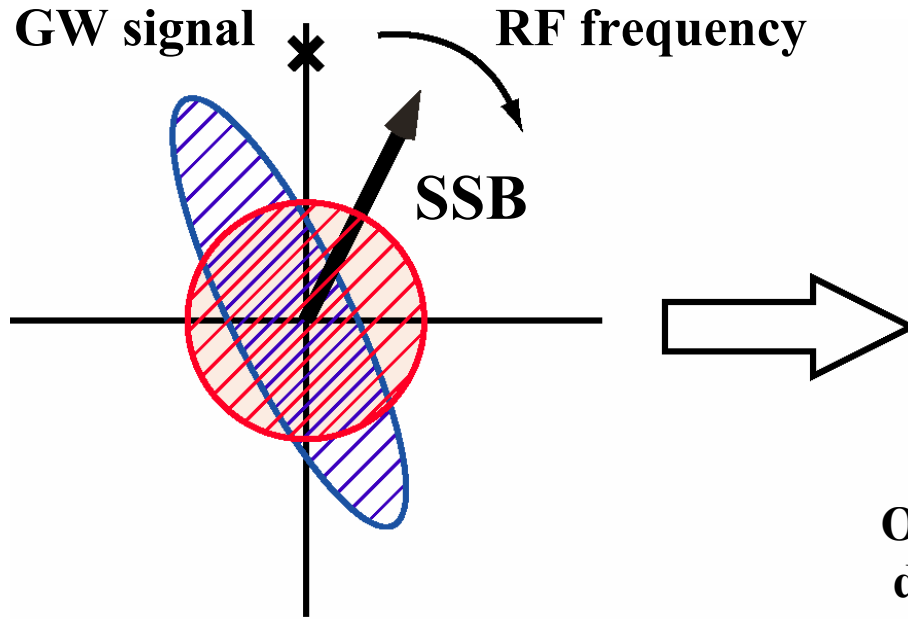

Demodulation phase determines the phase of this stroboscopic measurement.

Optimal demodulation phase shifts from 0 and the sensitivity is improved.

# A big problem: Vacuum at $2f_m$

(A.Buonanno, Y.Chen, and N.Mavalvala,  
Phys. Rev. D Vol.67, 2003)

Conventional shot noise

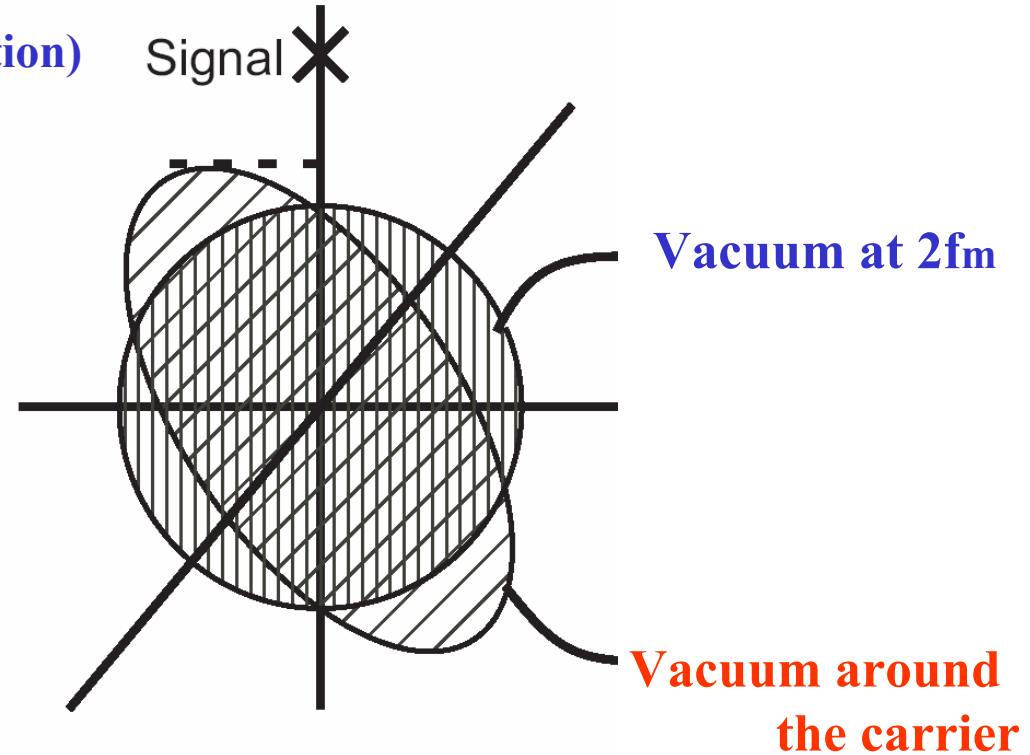
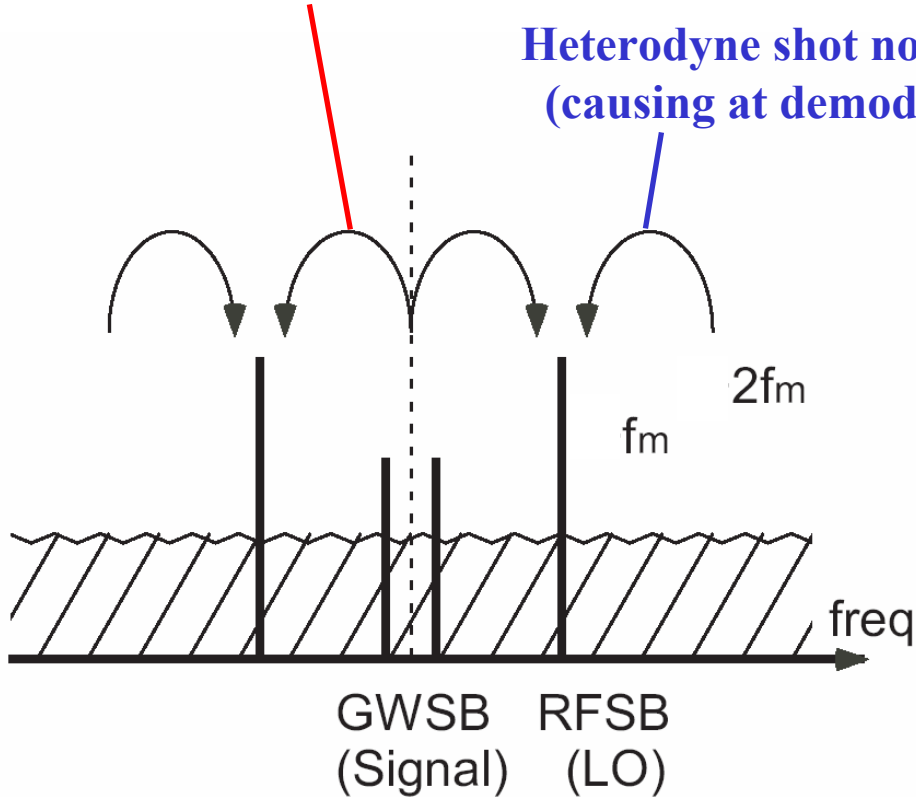

**Vacuum at  $2f_m$  is dominant at some readout phase.**

# RF Input Squeezing

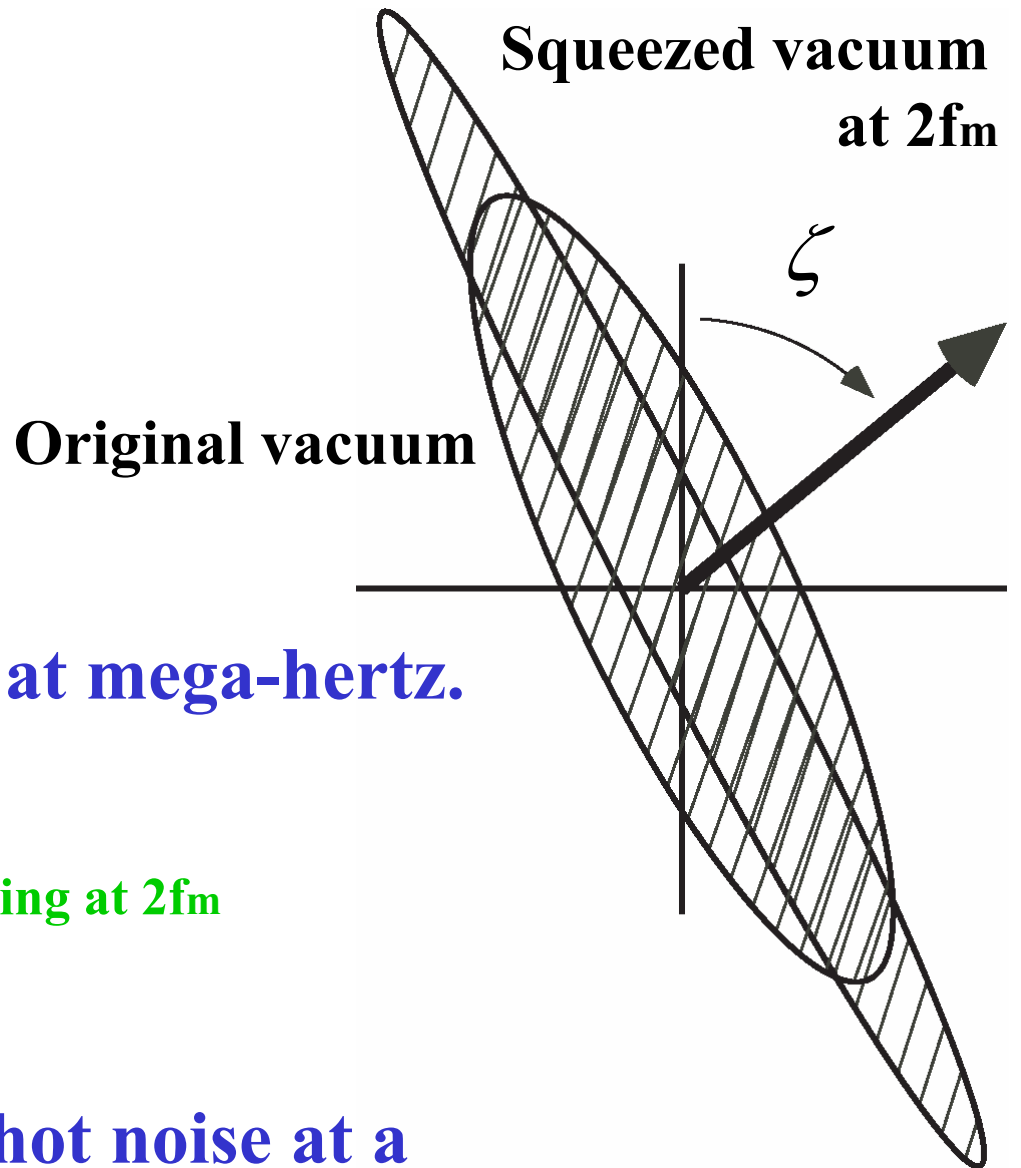

**Input Squeezing is available at mega-hertz.**



**Squeezing at  $2f_m$**

**We can reduce heterodyne shot noise at a particular frequency.**

# Quantum noise spectrum with RF Squeezing

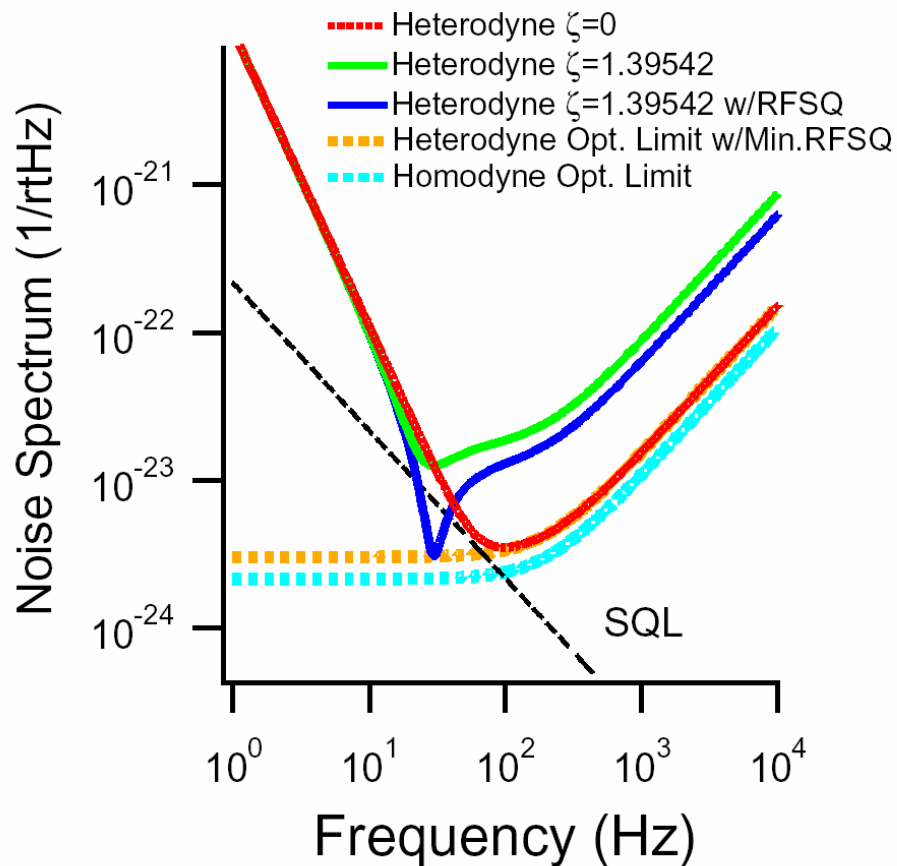

Squeeze factor  $R=1.76$

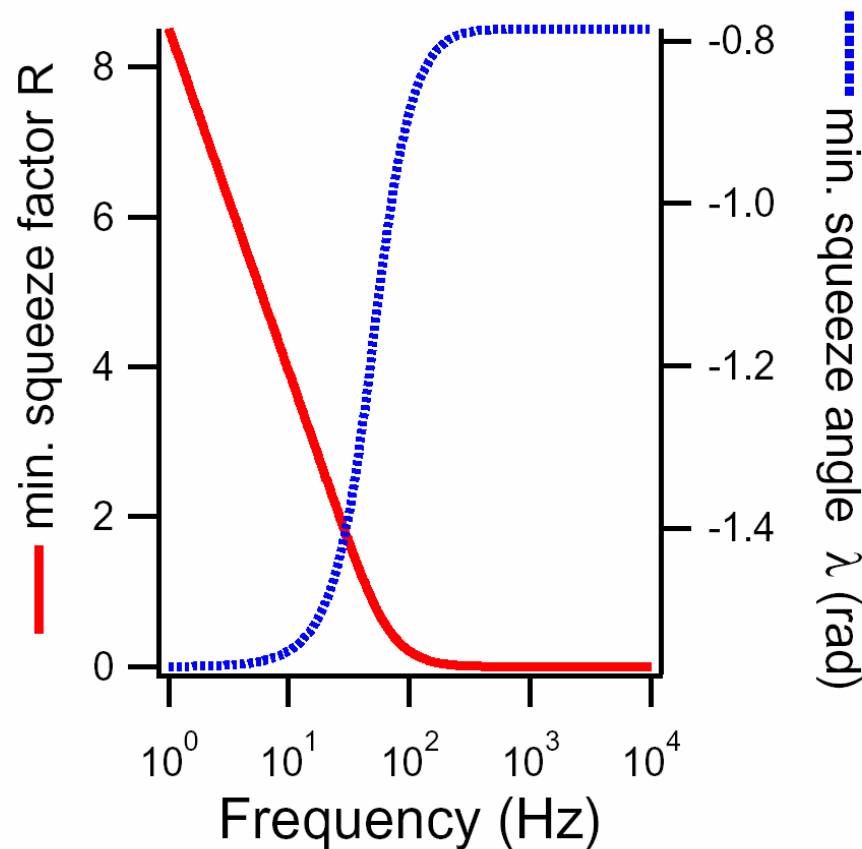

**While the peak cannot exceed the SQL with heterodyne shot noise, QND is realized with RF Squeezing !!**

# Multi-phase Detection

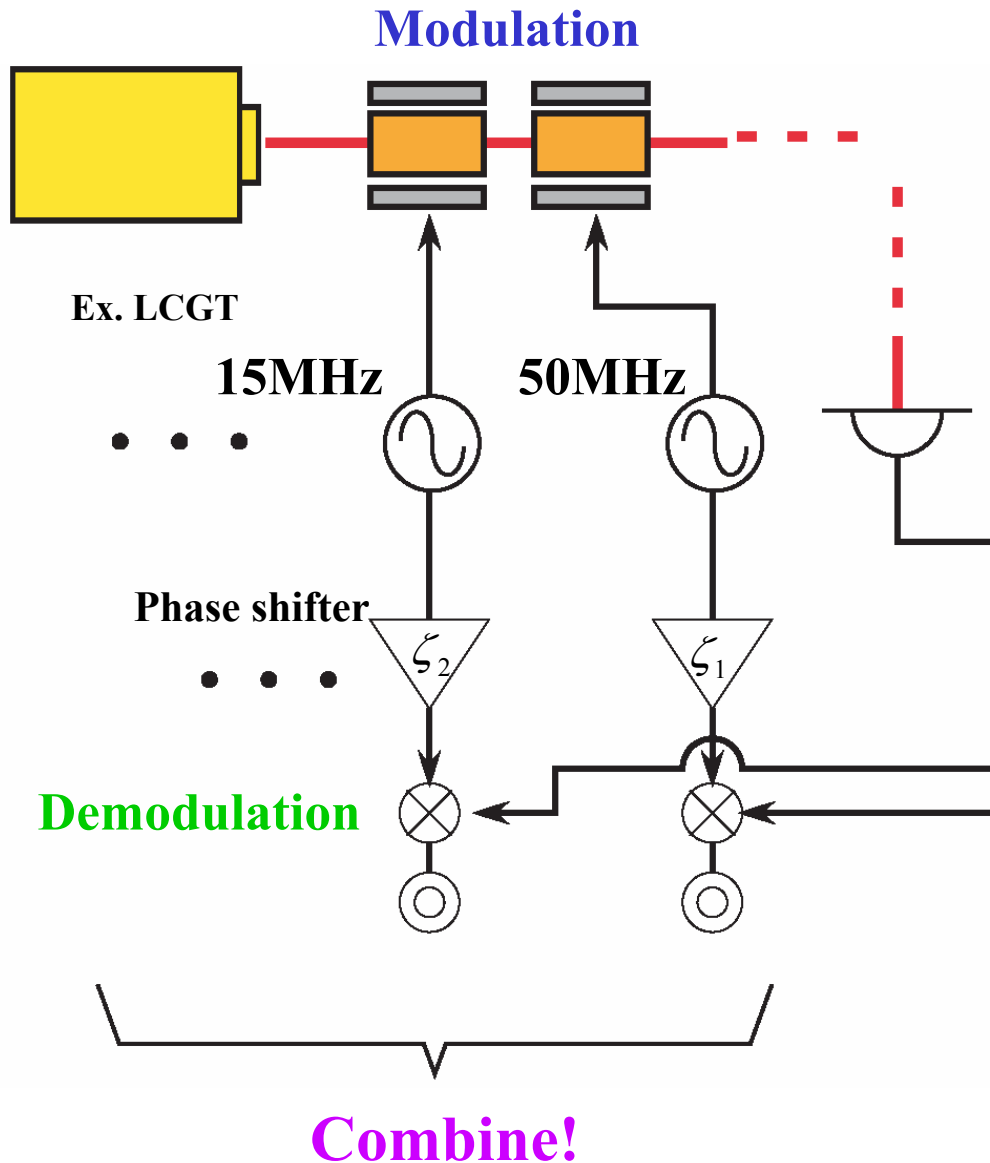

We cannot split the light not to reduce the signal amount.

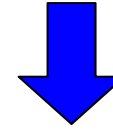

But we can split the electric field without signal degeneration.

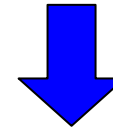

We can use all of them with different readout phase.

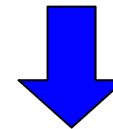

Practically two SBs will be available in a 2<sup>nd</sup> generation interferometer.

# Noise spectrum with Multi-phase Detection

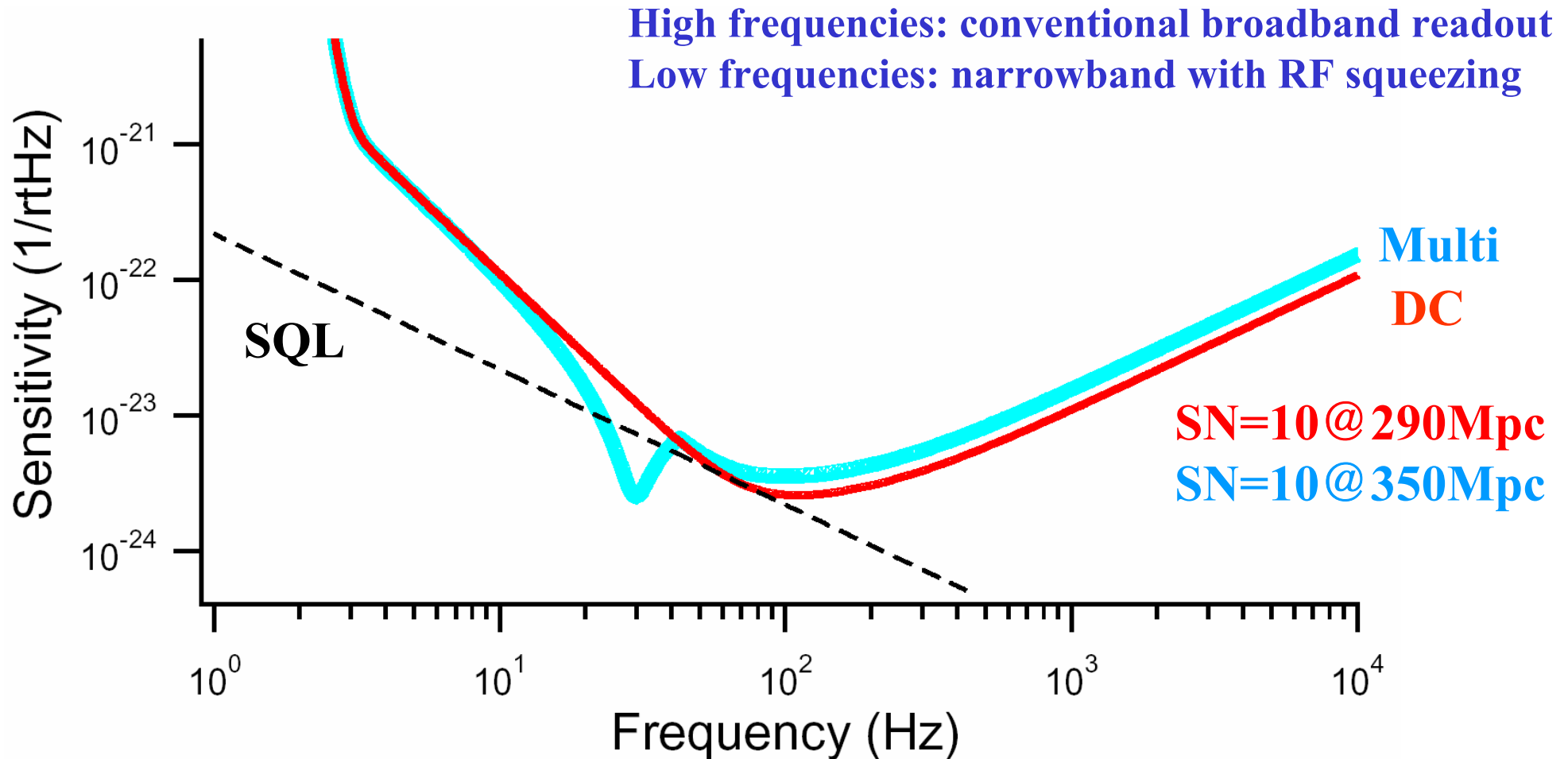

**The SNR for compact binaries is improved with keeping good sensitivity in broadband.**

# In the case of detuned configuration

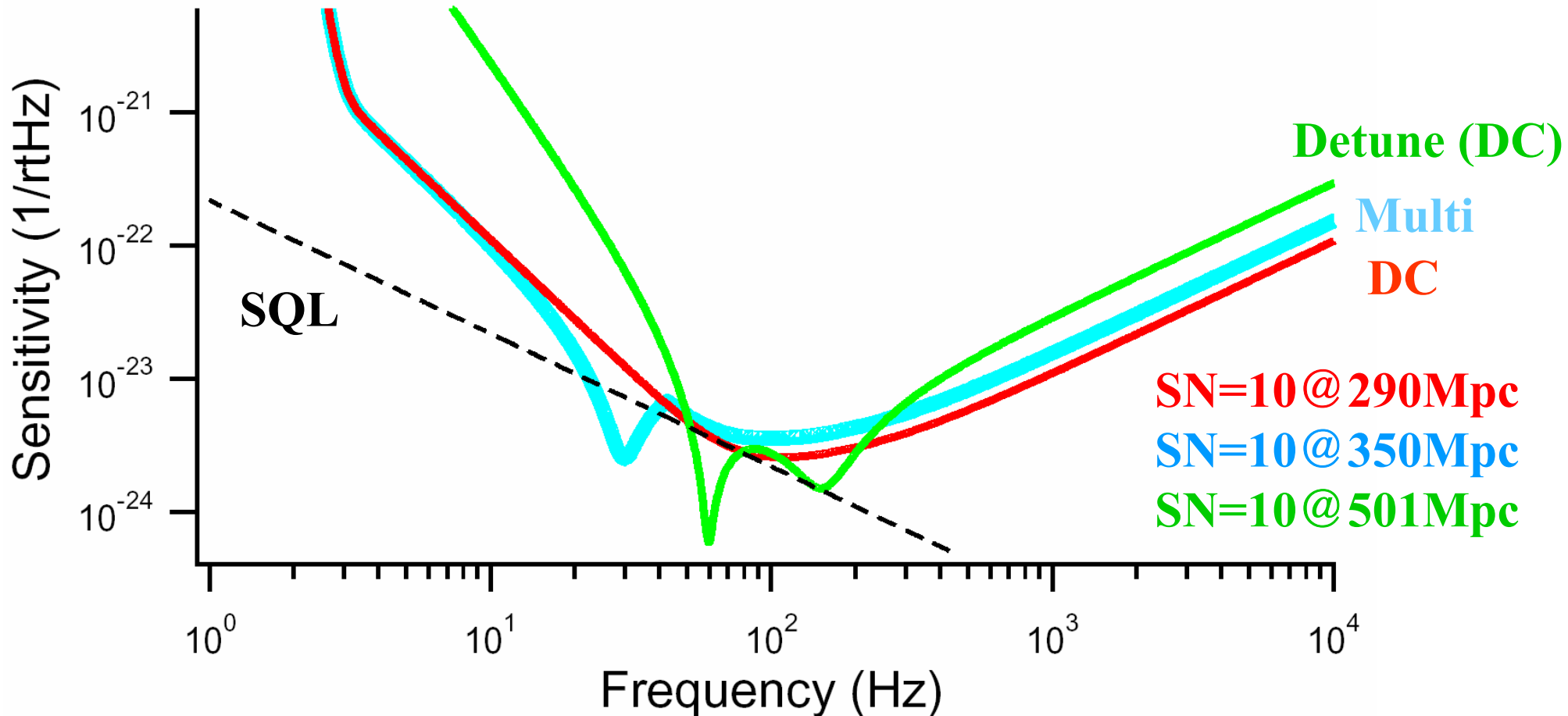



# Detuned RSE + Multi-phase Detection

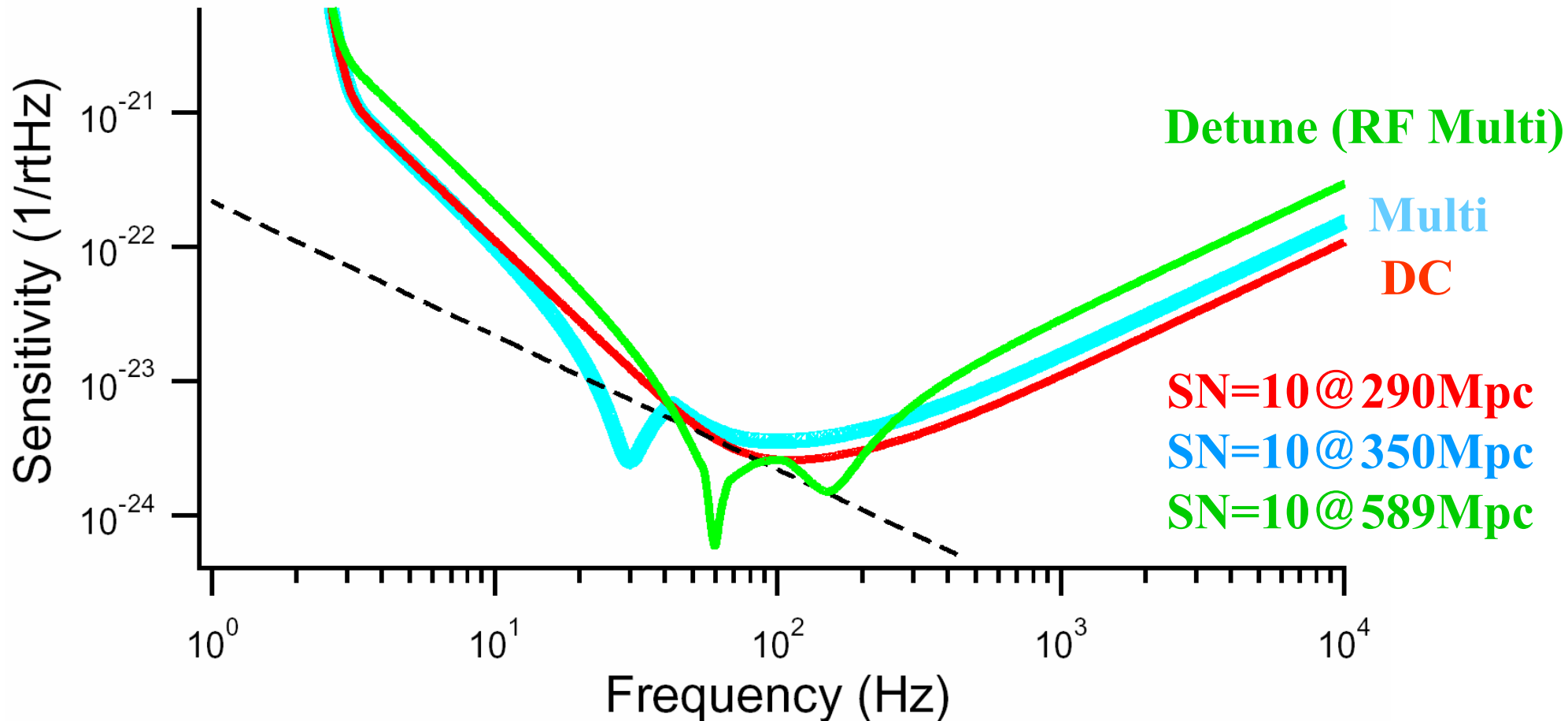

**Very broadband detuning !!**

# Summary

## QND techniques

**Input Squeezing**

Only available at very high frequency.

**Homodyne Detection**

DC is harder to handle.

## Conventional readout scheme

**RF Detection**

RF is easier to handle.



### Obstacles for QND measurement

- U/L sidebands make the readout phase fixed.

➔ **Unbalanced Sideband Detection**

- Vacuum at  $2f_m$  limits the sensitivity.

➔ **RF Squeeze**

➔ **Multi-phase detection makes the sensitivity improved and broad.**

# Discussion

**There are several conditions necessary to realize the RF squeezing:**

**(1) Asymmetry factor for  $2f_m$  vacuum should be a multiple of  $\pi$  to reflect all the input vacuum from DP to DP.**

**→ This is satisfied with a control scheme for RSE.**

**(2) Squeezing at  $2f_m+f$  and  $2f_m-f$  should be correlated (f: GWS freq.), or equivalently squeezed. (pointed out by Y.Chen)**

**→ This might be difficult. Need more investigation.**

# Discussion

