

# LIGO II Photodetector Requirements

---

Lasers and Optics Working Group  
LIGO Science Collaboration Meeting  
16 March, 2000

M. E. Zucker

# Optical & thermal requirements

---

- CW power handling

- Dark port with/without active thermal compensation: 1W? 10W?

- transient power handling

- reflection from PRC, MC ; full incident power, spike to 4x incident on unlock

- quantum efficiency

- shoot for 90% (trades w/laser power, but poorly)

- backscatter  $B_s < 10^{-7} \text{ sr}^{-1} \cdot \left( \frac{\partial\phi/\partial z_{TM}}{10^9 \text{ rad/m}} \right)^2 \left( \frac{z_{TM}}{10^{-20} \text{ m Hz}^{1/2}} \right)^2 \left( \frac{10^{-10} \text{ m Hz}^{1/2}}{z_{sc}} \right)^2 \left( \frac{M}{1/20} \right)^2 \left( \frac{P_{in}}{10 \text{ kW}} \right) \left( \frac{10}{s} \right)^2$

- Faraday isolators to reduce backscattered power?
- Seismic isolation of PD? In vacuum?

# Unlock transients & responses (conceptual)

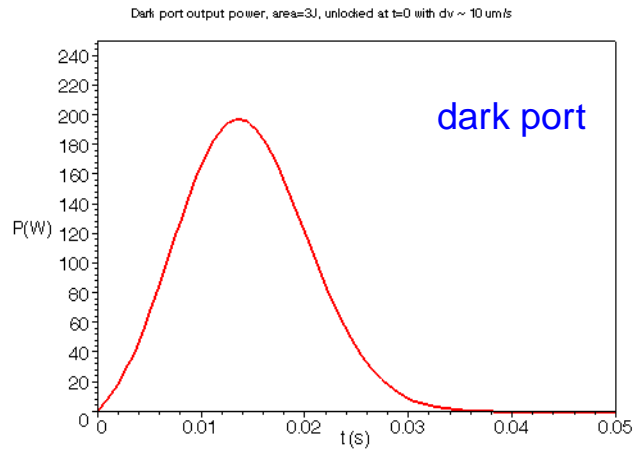

thermal device model

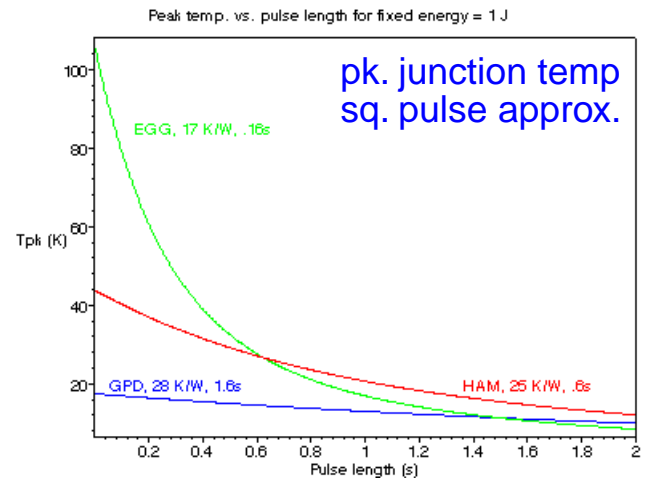
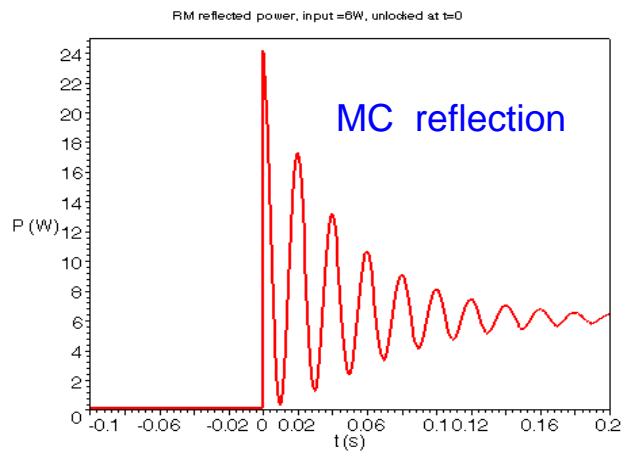
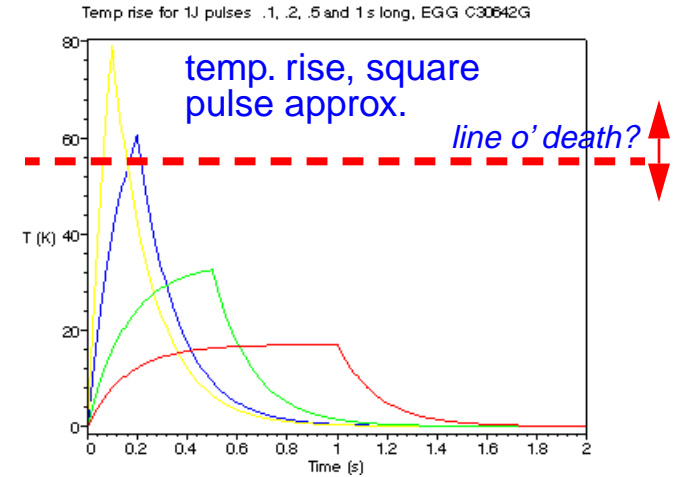
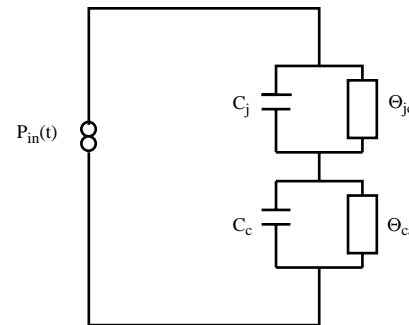

# Electrical & signal requirements

- RF frequency

- Want to provide for likely modulation schemes; “at least 2 shots at an MC or RM mirror position in each HAM” =>  $f_{RF} \approx 100$  MHz

- SNR (i.e., ‘shot:electronic noise ratio’)

- $\frac{e_{elec}^2}{e_{shot}^2} = \frac{1}{2eI_{DC}K_{mod}} \left( \frac{4k_B T}{Z_D} + \frac{e_n^2}{Z_D^2} + i_n^2 \right)$  with

$$Z_D(\omega_0) = \frac{1}{R_D \omega_0^2 C_D^2}$$

- power handling -> lower  $I_{DC}$

- SNR -> raise  $I_{DC}$

- e.g., 1.2 W, 1 nV/ $\sqrt{\text{Hz}}$ ,  $N=10$  diodes =>  $|Z_D(\omega_0)| > 150 \Omega$

- EGG G30642G, 100 MHz:  $|Z_D(100\text{MHz})| \approx 54 \Omega$  (OK @29 MHz)

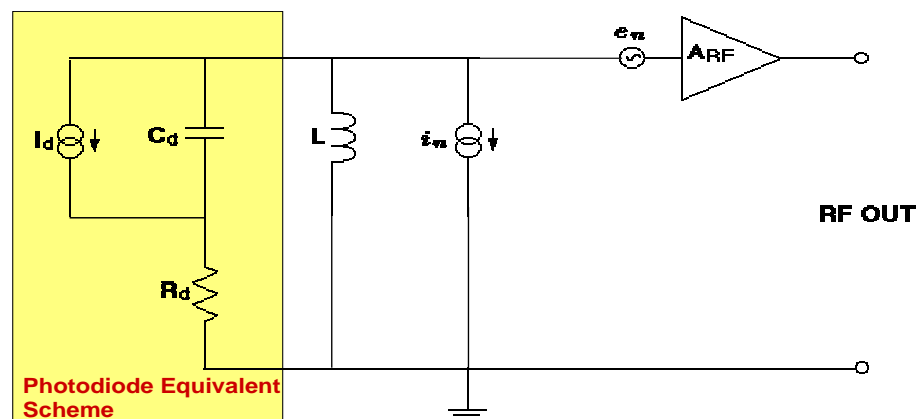

# Work needed (for req's definition, that is...)

---

- CW power handling (dark port output): Melody, FFT
- CW power handling (nonlinearities): E2E?
- Transient power handling: E2E
- Backscatter: IFO phase transfer function (Melody, E2E)
- SNR: Depends on DP power

# Rough Guess: PD Specs Scaled to LIGO II Power and Sensitivity

---

<i>Parameter</i>	<i>LIGO I</i>	<i>LIGO II guess</i>
Steady-state power	0.6 W	1.2 W <sup>a</sup> ?
Transient damage	3 J / 10 ms	30 J / 10 ms ?
Signal/Noise	$1.4 \times 10^{10} \text{ Hz}^{1/2}$	$3.1 \times 10^{10} \text{ Hz}^{1/2}$
Quantum efficiency	80%	90%
Spatial uniformity	1% RMS	0.1% RMS ?
Surface backscatter	$10^{-4} / \text{sr}$	$10^{-5} / \text{sr}^b$

a. Assumes significant improvement in contrast defect & cancellation of thermal lensing

b. Assumes Faraday isolator and seismic isolation of detector