

NOTES CONTINUED:
 5. MECHANICALLY STAMP (NO INKS OR DYES) PART NUMBER, REVISION AND SERIAL NUMBER .020 DEEP WITH MINIMUM CHARACTER HEIGHT .156 APPROXIMATELY WHERE SHOWN. SERIAL NUMBER WILL START AT 001 AND PROCEED CONSECUTIVELY.
 EXAMPLE: D100XXXX=V1
 S/N 001
 6. ALL PARTS SHALL BE MANUFACTURED IN ACCORDANCE WITH LIGO SPECIFICATION E0900364.
 7. ALL MATERIAL IS TO BE VIRGIN MATERIAL (i.e. NO WELD REPAIRS, PLUGS OR RECYCLED MATERIAL). NO REPAIRS SHALL BE MADE UNLESS APPROVED IN ADVANCE, AND IN WRITING, BY LIGO LABORATORY. REFER TO LIGO-E0900364.

8. SURFACE FINISH TO BE AS-PROCRSSED FROM MILL/SUPPLIER, FREE FROM SCRATCHES AND GOUGES

REV.	DATE	DCN #	DRAWING TREE #
v1	18 JAN 2011	E1100258	-
v2	20 APR 2011	E1100258	-
v3	7 SEP 2011	D1100335-v4	-
v4	12 MAR 2012	D1100335	-

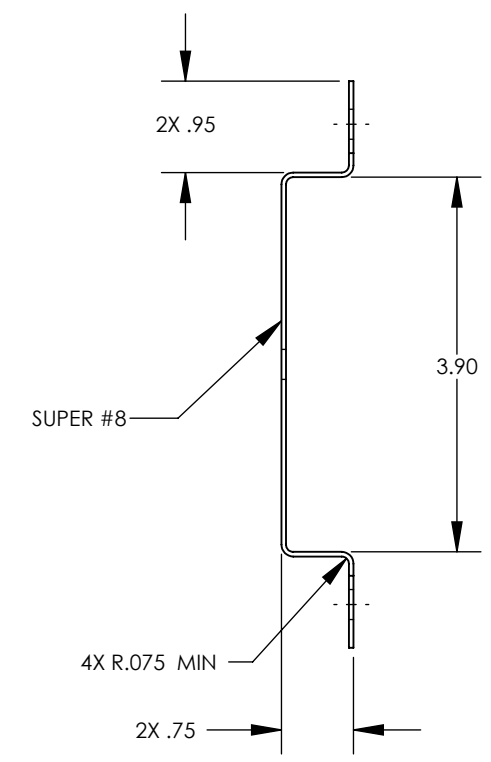
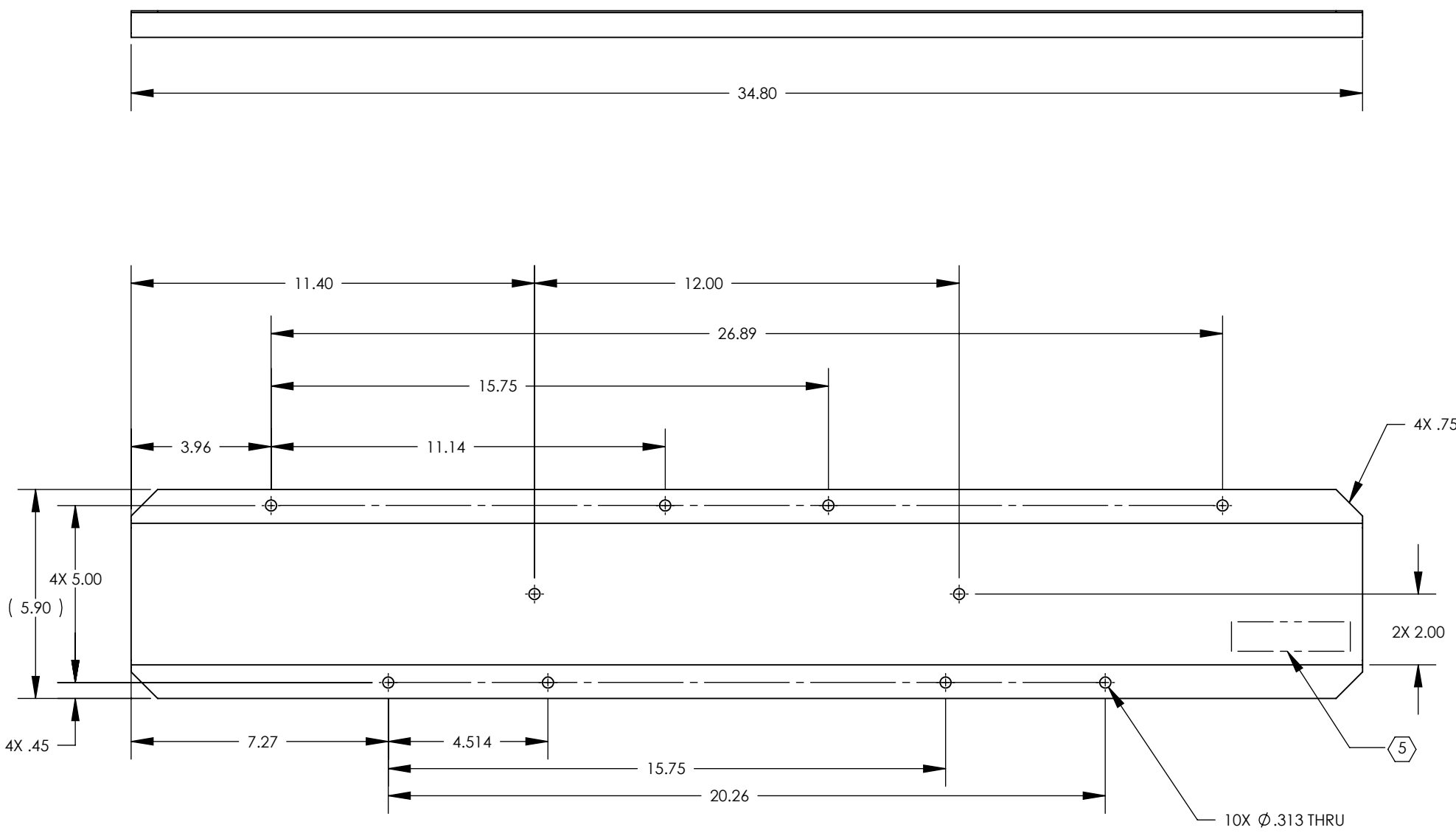

SECTION A-A
SCALE 1 : 2

D1100074_AdlIGO_AOS_ACB Inner Skin Porcelain Hanging Fixture, PART PDM REV: X-010, DRAWING PDM REV: X-018

NOTES AND TOLERANCES: (UNLESS OTHERWISE SPECIFIED)	
DIMENSIONS ARE IN INCHES	
TOLERANCES: .XX ± .03 .XXX ± .015 ANGULAR ± 1.0°	
MATERIAL	18 GAUGE 304 SSSL
FINISH	SUPER #8 8



LIGO CALIFORNIA INSTITUTE OF TECHNOLOGY
 MASSACHUSETTS INSTITUTE OF TECHNOLOGY

SYSTEM: ADVANCED LIGO
 SUB-SYSTEM: AOS
 NEXT ASSY: D1100075

PART NAME			ACB INNER SKIN PORCELAIN HANGING FIXTURE		
DESIGNER	N. Nguyen	12 Jan 2011	SIZE	DWG. NO. D1100074	
DRAFTER	N. Kilpatrick	18 Jan 2011	REV.	v4	
CHECKER	M. Smith	21 Mar 2011	SCALE	1:4	
APPROVAL	D. Coyne	25 Mar 2011	PROJECTION	FIRST ANGLE	
			SHEET	1 OF 2	

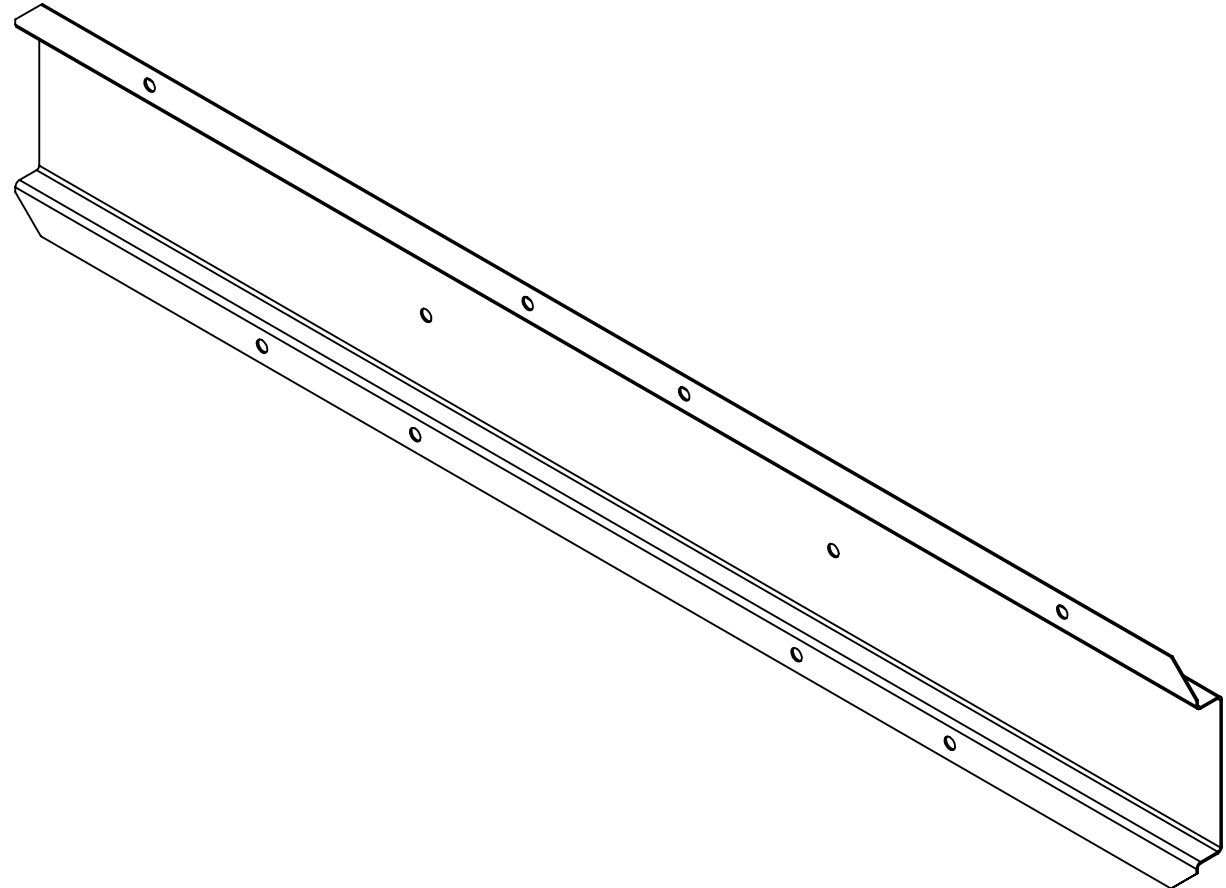
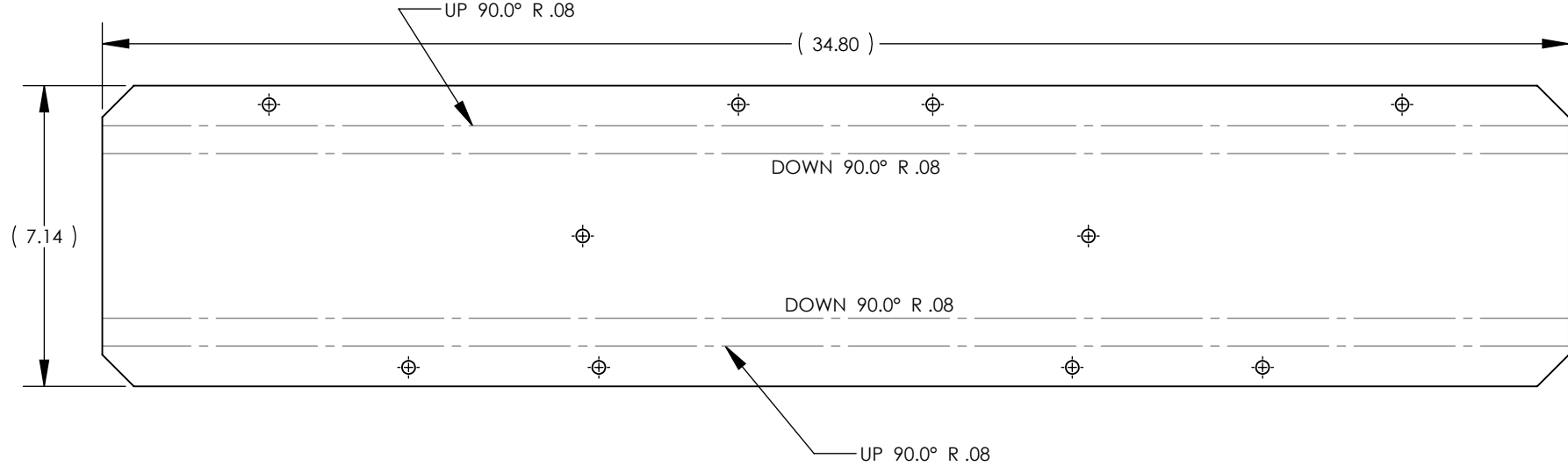
D1100074_AdLIGO_AOS_ACB_Inner Skin Porcelain Hanging Fixture, PART PDM REV: X-010, DRAWING PDM REV: X-018



 CALIFORNIA INSTITUTE OF TECHNOLOGY MASSACHUSETTS INSTITUTE OF TECHNOLOGY		
SIZE B	DWG. NO. D1100074	REV. v4
SCALE: 1:4	PROJECTION: 	SHEET 2 OF 2