

**NOTES CONTINUED:**  
 5. SCRIBE, ENGRAVE (A VIBRATORY TOOL MAY BE USED), LASER MARK OR MECHANICALLY STAMP (NO INKS OR DYES) DRAWING PART NUMBER, REVISION (AND VARIANT OR "TYPE" IF APPLICABLE) ON NOTED SURFACE OF PART FOLLOWED ON THE NEXT LINE WITH A THREE DIGIT SERIAL NUMBER. SERIAL NUMBERS START AT 001 FOR THE FIRST ARTICLE AND PROCEED CONSECUTIVELY. USE MINIMUM 0.12" HIGH CHARACTERS, UNLESS THE SIZE OF THE PART DICTATES SMALLER CHARACTERS. EXAMPLE: DXXXXXX-VY, TYPE-XX, S/N XXX

8. SURFACE FINISH TO BE AS-PROCRSSED FROM MILL/SUPPLIER, FREE FROM SCRATCHES AND GOUGES

6. ALL PARTS SHALL BE MANUFACTURED IN ACCORDANCE WITH LIGO SPECIFICATION E0900364.  
 7. ALL MATERIAL IS TO BE VIRGIN MATERIAL (i.e. NO WELD REPAIRS, PLUGS OR RECYCLED MATERIAL). NO REPAIRS SHALL BE MADE UNLESS APPROVED IN ADVANCE, AND IN WRITING, BY LIGO LABORATORY. REFER TO LIGO-E0900364.

REV.	DATE	DCN #	DRAWING TREE #
v1	18 JAN 2011	E1100258	-
v2	20 APR 2011	E1100258	-
v3	7 SEP 2011	D1100335-v4	-

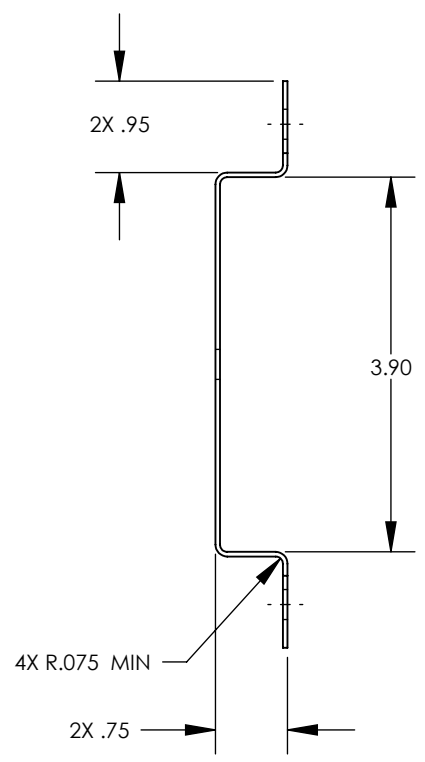
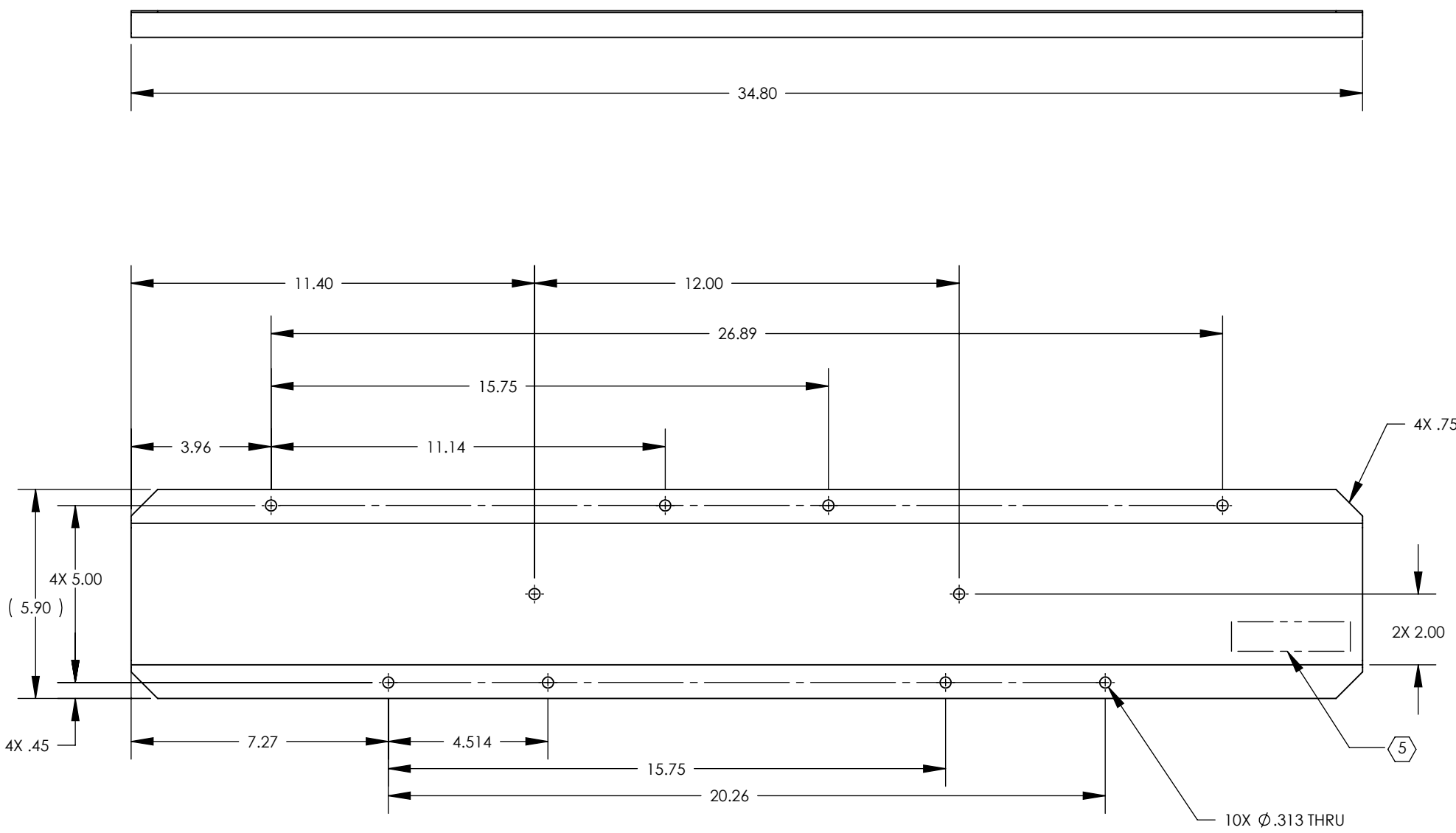

D1100074\_AdlIGO\_AOS\_ACB Inner Skin Porcelain Hanging Fixture, PART PDM REV: X-010, DRAWING PDM REV: X-017

NOTES AND TOLERANCES: (UNLESS OTHERWISE SPECIFIED)	
DIMENSIONS ARE IN INCHES	
TOLERANCES: .XX ± .03 .XXX ± .015 ANGULAR ± 1.0°	
1. INTERPRET DRAWING PER ASME Y14.5-1994. 2. REMOVE ALL SHARP EDGES, .005-.015, FOR MACHINED PARTS. ROUND ALL EDGES APPROXIMATELY R.02 FOR SHEET METAL PARTS. 3. DO NOT SCALE FROM DRAWING. 4. ALL MACHINING FLUIDS MUST BE FULLY SYNTHETIC, FULLY WATER SOLUBLE AND FREE OF SULFUR, SILICONE, AND CHLORINE.	
MATERIAL	FINISH
18 GAUGE 304 SSSL	SUPER #8 8

**LIGO** CALIFORNIA INSTITUTE OF TECHNOLOGY  
 MASSACHUSETTS INSTITUTE OF TECHNOLOGY

SYSTEM: **ADVANCED LIGO** SUB-SYSTEM: **AOS**

NEXT ASSY: **D1100075**

PART NAME			ACB INNER SKIN PORCELAIN HANGING FIXTURE		
DESIGNER	N. Nguyen	12 Jan 2011	SIZE	DWG. NO.	
DRAFTER	N. Kilpatrick	18 Jan 2011	<b>B</b>	<b>D1100074</b>	
CHECKER	M. Smith	21 Mar 2011	SCALE:	1:4	PROJECTION:
APPROVAL	D. Coyne	25 Mar 2011	SHEET	1 OF 2	
REV.	v3				

D1100074\_AdLIGO\_AOS\_ACB\_Inner Skin Porcelain Hanging Fixture, PART PDM REV: X-010, DRAWING PDM REV: X-017

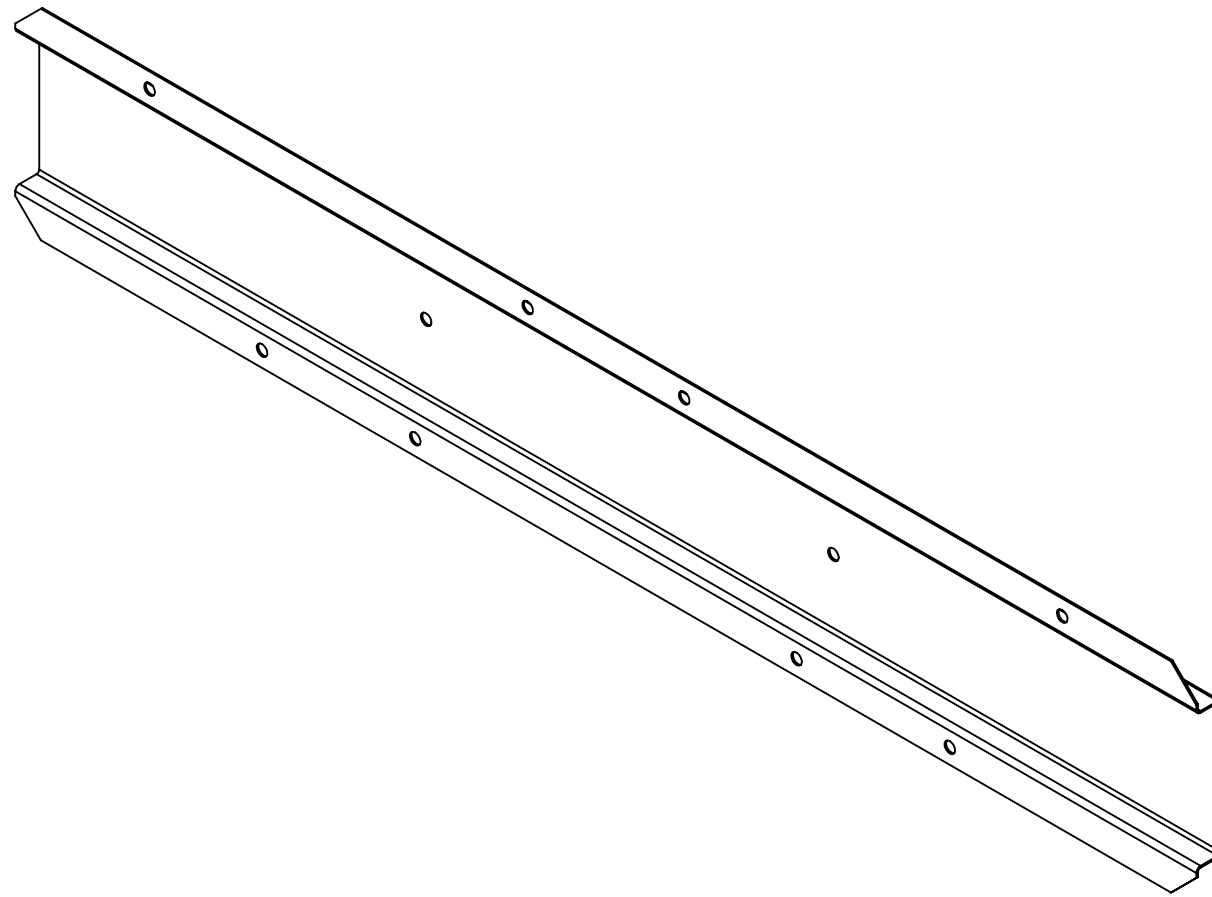
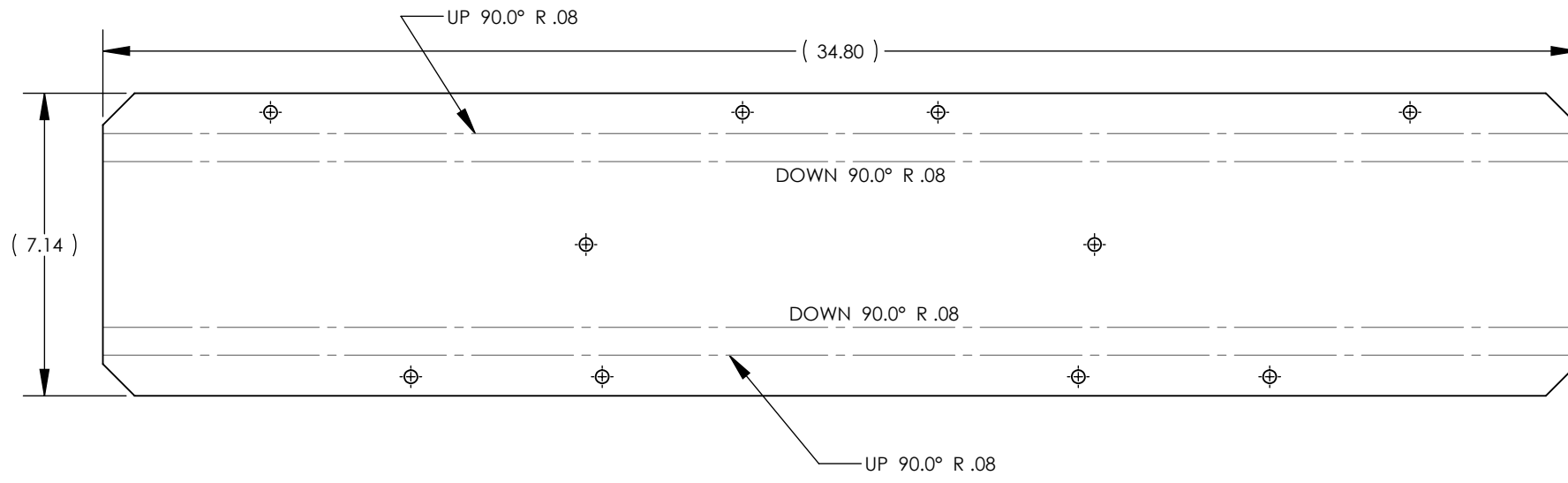

 <b>CALIFORNIA INSTITUTE OF TECHNOLOGY</b> <b>MASSACHUSETTS INSTITUTE OF TECHNOLOGY</b>		
SIZE	DWG. NO.	REV.
<b>B</b>	D1100074	<b>v3</b>
SCALE: 1:4	PROJECTION:	SHEET 2 OF 2