

LASER INTERFEROMETER GRAVITATIONAL WAVE OBSERVATORY  
- LIGO -  
CALIFORNIA INSTITUTE OF TECHNOLOGY  
MASSACHUSETTS INSTITUTE OF TECHNOLOGY

<b>Document Type</b>	<b>LIGO-T980072-01</b>	<b>D</b>	<b>5/13/99</b>
<b>COS IR Autocollimator Alignment System</b>			
Michael Smith			

*Distribution of this draft:*

xyz

This is an internal working note  
of the LIGO Project.

**California Institute of Technology**  
**LIGO Project - MS 51-33**  
**Pasadena CA 91125**  
Phone (626) 395-2129  
Fax (626) 304-9834  
E-mail: info@ligo.caltech.edu

**Massachusetts Institute of Technology**  
**LIGO Project - MS 20B-145**  
**Cambridge, MA 01239**  
Phone (617) 253-4824  
Fax (617) 253-7014  
E-mail: info@ligo.mit.edu

WWW: <http://www.ligo.caltech.edu/>

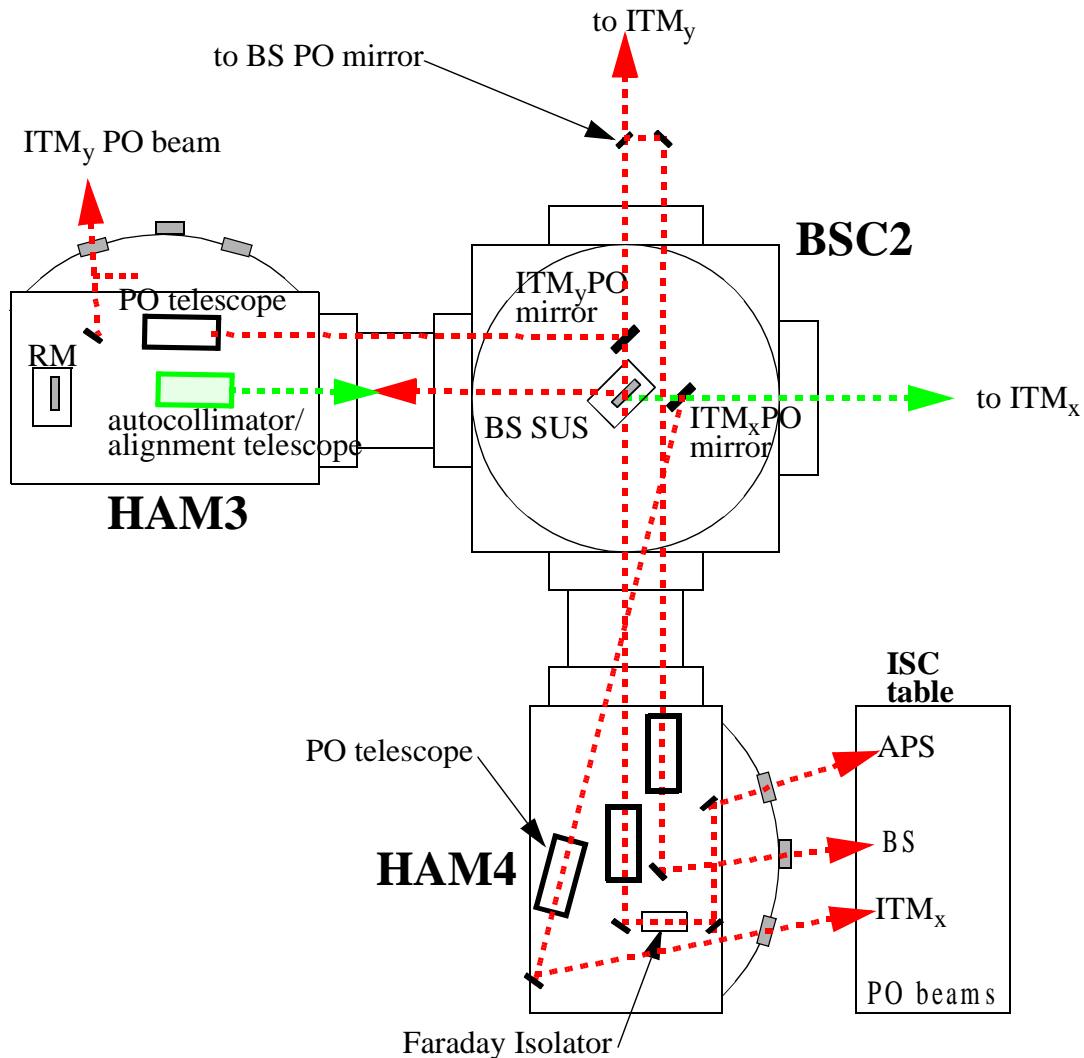
LIGO DRAFT

# 1 OVERVIEW

An IR alignment telescope/autocollimator will be used to establish the locations of the beam-dumps, baffles, PO mirrors, and PO telescopes in the IFO; and to align the optical axes of the PO telescopes. The autocollimator mode will be used for setting the COS alignment beam parallel to the IFO optical axis, and for aligning the optical axes of the PO telescopes. The alignment telescope mode will be used to project a focussed reticle alignment mark for centering the alignment beam, beam-dumps, baffles, PO mirrors, and PO telescopes.

# 2 COS ALIGNMENT BEAM

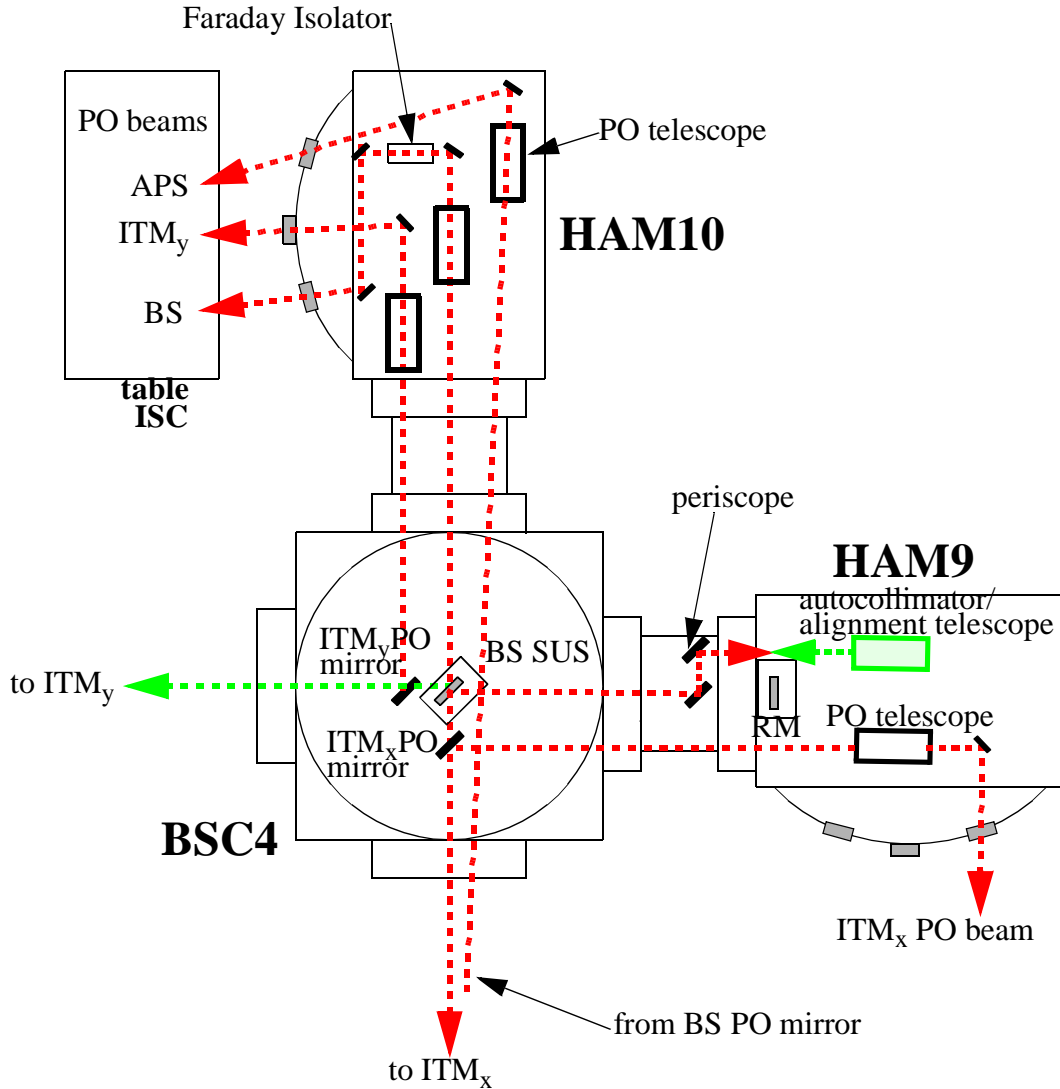
The IR autocollimator/alignment telescope will be placed on the SEI platform in HAM3 to provide an alignment beam for the 4K IFO, as shown in figure1. First the alignment telescope will be focussed to project an image of the reticle onto a target centered on the ITM<sub>x</sub>.



**Figure 1: Alignment Beams for COS, 4K IFO**

Next the autocollimator will be focussed at infinity and adjusted in pointing angle so that the reflected reticle image is nulled, making the beam perpendicular to the  $ITM_x$ . Finally the tilt and displacement of the autocollimator will be iteratively adjusted until the alignment beam is both centered and perpendicular to the  $ITM_x$ .

The same procedure will be used in the 2K IFO. However, a periscope adapter will be required in HAM9 to get around the RM LOS structure, as shown in figure 2.



**Figure 2: Alignment Beams for COS, 2K IFO**

### 3 POSITIONING OF COS OPTICAL ELEMENTS

Ghost alignment beams will be generated by the wedge surfaces of each COC. Each COS optical element, e.g. the PO mirrors, beam-dumps, etc., will be positioned by focussing the alignment

telescope and projecting a ghost reticle onto a temporary target centered on each optical element; then by moving the element until the target is centered on the projected reticle. The alignment telescope has a sufficient focus range, and the beam remains centered with the mechanical axis over the entire focus range.

### 3.1. IR Autocollimator Illumination Requirements

The illumination of the IR autocollimator/alignment telescope is sufficient to enable the weakest ghost beam projected reticle to be viewed with a sensitive commercial surveillance camera, such as the Watec WAT-902H with a minimum luminous sensitivity of 0.0003 lux. As shown in Table 1 on page 4, a 100 mw 940 nm light source will produce adequate illumination of 0.008 lux in the 2KGBITMAR4 weakest ghost beam--a factor 26 higher than the minimum luminous sensitivity of the camera.

**Table 1:**

<i>IFO</i>	<i>Beam</i>	<i>location</i>	<i>Power @ 940nm, W</i>	<i>power density, W/cm<sup>2</sup></i>	<i>distance, m</i>	<i>beam area, m<sup>2</sup></i>	<i>illumination of target, lux</i>
LHO	4Kalignment x	target at 4KBS LOS	3.20E-02	3.90E-04	3.83E+00	8.20E-03	5.35E+02
LHO	4Kalignment x, retro	HAM3	3.18E-03	8.04E-06	8.41E+00	3.95E-02	2.75E+02
LHO	4Kalignment y, retro	HAM3	3.31E-03	8.37E-06	8.41E+00	3.95E-02	2.87E+02
LHO	4KAPSxPO beam	HAM3	3.18E-03	3.79E-06	1.22E+01	8.37E-02	5.20E+00
LHO	4KAPSxTEL out	HAM3	1.91E-04	6.07E-05		3.14E-04	8.32E+01
LHO	4KAPSxTEL, align	HAM3	7.63E-05				8.32E+02
LHO	4KAPSx PO ISC	output window	5.93E-05	1.89E-05		3.14E-04	2.59E+01
LHO	4KITMx PO beam	HAM4	6.54E-04	4.14E-07	1.68E+01	1.58E-01	5.67E-01
LHO	4KITMx TEL out	HAM4	2.08E-05	6.63E-06		3.14E-04	9.08E+00
LHO	4KITMx TEL, align	HAM4	8.33E-06				9.08E+01
LHO	4KITMx PO ISC	output window	1.39E-05	4.43E-06		3.14E-04	6.07E+00
LHO	4KITMy PO beam	HAM4	6.68E-04	4.23E-07	1.68E+01	1.58E-01	5.79E-01
LHO	4KITMy TEL out	HAM4	2.12E-05	6.76E-06		3.14E-04	9.26E+00
LHO	4KITMy TEL, align	HAM4	8.50E-06				9.26E+01
LHO	4KITMy PO ISC	output window	1.42E-05	4.52E-06		3.14E-04	6.19E+00
LHO	4KBS PO beam	HAM4	1.57E-04	9.92E-08	1.68E+01	1.58E-01	1.36E-01
LHO	4KBS PO TEL out	HAM4	4.99E-06	1.59E-06		3.14E-04	2.17E+00
LHO	4KBS TEL, align	HAM4	1.99E-06				2.17E+01
LHO	4KBS PO ISC	output window	1.38E-05	4.38E-06		3.14E-04	6.01E+00
LHO	4KGBITMxAR1	beam dump BSC2	2.67E-03	2.83E-06	1.30E+01	9.43E-02	3.87E+00
LHO	4KGBITMxAR4	beam dump BSC2	6.74E-05	7.15E-08	1.30E+01	9.43E-02	9.80E-02
LHO	4KGBITMxAR3	ITMx PO mirror	6.61E-04	7.01E-07	1.30E+01	9.43E-02	9.61E-01
LHO	4KGBITMxHR3	beam dump BSC7	5.31E-04	5.63E-07	1.30E+01	9.43E-02	7.72E-01
LHO	4KGBITMxHR4	beam dump BSC7	5.42E-05	1.37E-07	1.30E+01	3.95E-02	1.88E-01
LHO	4KGBBSAR3x	beam dump BSC3	1.57E-04	1.66E-07	8.41E+00	9.43E-02	2.28E-01
LHO	4KGBBSHR3y	BS PO mirror	1.60E-04	4.05E-07	8.41E+00	3.95E-02	5.55E-01
LHO	4KGBBSAR1y'	beam dump HAM4	1.30E-04	8.20E-08	1.68E+01	1.58E-01	1.12E-01
LHO	4KGBBSAR3y'	beam dump HAM4	3.18E-03	2.01E-06	1.68E+01	1.58E-01	2.75E+00
LHO	4KGBBSHR3p	beam dump HAM3	3.18E-05	2.01E-08	1.68E+01	1.58E-01	2.75E-02

<i>I/O</i>	<i>Beam</i>	<i>location</i>	<i>Power @ 940nm, W</i>	<i>power density, W/cm<sup>2</sup></i>	<i>distance, m</i>	<i>beam area, m<sup>2</sup></i>	<i>illumination of target, lux</i>
------------	-------------	-----------------	-------------------------	--	--------------------	---------------------------------	------------------------------------

LHO	4KGBITMyAR1	beam dump BSC2	2.72E-03	2.89E-06	1.30E+01	9.43E-02	3.95E+00
LHO	4KGBITMyAR4	beam dump BSC2	6.88E-05	7.30E-08	1.30E+01	9.43E-02	1.00E-01
LHO	4KGBITMyAR3	ITMy PO mirror	6.75E-04	7.16E-07	1.30E+01	9.43E-02	9.80E-01
LHO	4KGBITMyHR3	beam dump BSC8	5.42E-04	5.75E-07	1.30E+01	9.43E-02	7.88E-01
LHO	4KGBITMyHR4	beam dump BSC8	5.53E-05	5.86E-08	1.30E+01	9.43E-02	8.03E-02
LHO	2Kalignment x	target at 2KBS LOS	3.20E-02	3.90E-04	3.83E+00	8.20E-03	5.35E+02
LHO	2Kalignment x, retro	HAM9	3.31E-04	8.69E-08	2.61E+01	3.81E-01	2.98E+00
LHO	2Kalignment y, retro	HAM9	3.18E-04	8.35E-08	2.61E+01	3.81E-01	2.86E+00
LHO	2KAPSxPO beam	HAM10	7.94E-04	2.09E-07	2.61E+01	3.81E-01	2.86E-01
LHO	2KAPSxTEL out	HAM10	1.05E-05	3.34E-06	2.61E+01	3.14E-04	4.57E+00
LHO	2KAPSxTEL, align	HAM10	4.20E-06				4.57E+01
LHO	2KAPSx PO ISC	output window	3.26E-06	1.04E-06	2.91E+01	3.14E-04	1.42E+00
LHO	2KGBITMxAR3	PO mir BSC4	1.69E-04	6.09E-08	2.23E+01	2.77E-01	8.34E-02
LHO	2KITMx PO beam	HAM9	1.67E-04	4.39E-08	2.61E+01	3.81E-01	6.01E-02
LHO	2KITMx TEL out	HAM9	2.21E-06	7.02E-07	2.91E+01	3.14E-04	9.62E-01
LHO	2KITMx TEL, align	HAM9	8.82E-07				9.62E+00
LHO	2KITMx PO ISC	output window	1.47E-06	4.69E-07	2.91E+01	3.14E-04	6.43E-01
LHO	2KGBBSHR3y	PO mir BSC7	1.60E-04	3.37E-07	9.22E+00	4.75E-02	4.62E-01
LHO	2KBS PO beam	HAM10	1.58E-04	4.16E-08	2.61E+01	3.81E-01	5.70E-02
LHO	2KBS PO TEL out	HAM10	2.09E-06	6.66E-07	2.91E+01	3.14E-04	9.12E-01
LHO	2KBS TEL, align	HAM10	8.37E-07				9.12E+00
LHO	2KBS PO ISC	output window	1.38E-06	4.41E-07	2.91E+01	3.14E-04	6.04E-01
LHO	2KGBITMyAR3	PO mir BSC4	3.31E-04	1.19E-07	2.23E+01	2.77E-01	1.63E-01
LHO	2KITMy PO beam	HAM10	3.27E-04	8.60E-08	2.61E+01	3.81E-01	1.18E-01
LHO	2KITMy TEL out	HAM10	4.32E-06	1.38E-06	2.91E+01	3.14E-04	1.88E+00

## 3.2. IR Autocollimator/Alignment Telescope Hardware

### 3.2.1. Autocollimator/Alignment Telescope

A Davidson Model D-271-106 alignment telescope will be used both as a projection alignment telescope and an autocollimator. A 500 mW fiber-coupled infrared laser @ 940 nm from Applied Optonics Corp. will be used as the light source for illuminating the internal reticle. (LEDs are available with <10 mW, but will not provide sufficient illumination.) The laser is coupled to a 100 micron diameter fiber with a NA=0.2, which results in a 23 degree full angle light cone. The cone will be transformed with a lens to match the NA=0.1 of the alignment telescope and thereby achieve high transmissivity through the alignment telescope. The collimating optics of the alignment telescope will be AR coated at 500nm and 940nm to enable operation both with visible light and infrared light sources. A holographic diffusing screen may be placed in front of the reticle to provide uniform illumination.

### 3.3. Safe Viewing Requirements

The safe viewing requirements meet the specifications of ANSI Z136.1 -1993, American National Standard for Safe Use of Lasers.

#### 3.3.1. Laser System Classification

The use of a 500 mW infrared laser as an illumination source categorizes the alignment telescope/ autocollimator as a class 3b laser system, because the maximum accessible emission at the output of the telescope is  $> 1 \text{ mW}$  and  $< 0.5 \text{ W}$  (Appendix A, Table A1, ANSI Z136.1 -1993)

#### 3.3.2. Engineering Controls

##### 3.3.2.1 Norminal Hazard Zone (NHZ)

The maximum permissible exposure (MPE) for direct intrabeam viewing is  $5 \times 10^{-3} \frac{\text{W}}{\text{cm}^2}$  (see Fig. 4, middle curve @ 10 sec. exposure, ANSI Z136.1 -1993). The alignment telescope output beam area expands proportional to the square of the distance from the telescope, and the distance beyond which the emitted flux density is less than the MPE is  $L_{\text{safe}} > 4.2 \text{ m}$ . Therefore the NHZ encompasses the region within a sphere of 4.2 m radius. It is safe to view the beam directly beyond this distance.

There are two intended use areas for the alignment telescope: 1) inside the optics lab, and 2) inside the IFO chambers. Inside the use area, Class 3b warning signs will be posted, and access will be restricted to authorized COS personnel.

Personnel will be required to wear protective eye goggles with  $\text{ND} > 2$  @ 940 nm when in the use areas and within the NHZ. It will be optional to wear protective eye goggles in the use area beyond the NHZ.

##### 3.3.2.2 Viewing with Collecting Optics

Normally a CCD camera is attached to the eyepiece of the alignment telescope for viewing of the infrared image. However, in some instances it will be necessary to remove the infrared laser source and the CCD camera from the alignment telescope, substitute a visible incoherent light source, and look directly into the eyepiece.

An electrical interlock will be provided so that whenever the CCD camera is removed, the infrared laser source can not operate.

##### 3.3.2.3 Eye Protection

Eye protection must be worn when working within the NHZ. The safe attenuation factor for momentary intrabeam viewing  $< 10 \text{ sec}$  of a 1 W laser source is OD3 (see Table 4, ANSI Z136.1 -1993).

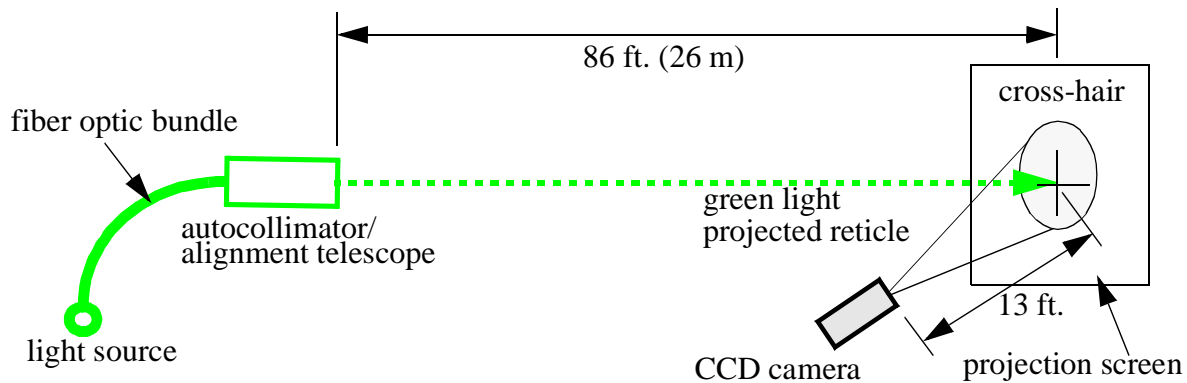
The alignment telescope beam is safe for direct intrabeam viewing at distances beyond the NHZ, and no eye protection is required.

### 3.3.2.4 Access Restriction

The area in which the infrared alignment telescope is being used is a Class 3b laser controlled area. Warning signs will be posted at all access locations into the use area. Only authorized COS personnel will be allowed inside the use area.

## 3.4. Preliminary Results

A preliminary test of the reticle projection technique was performed with the apparatus shown schematically in figure 3.

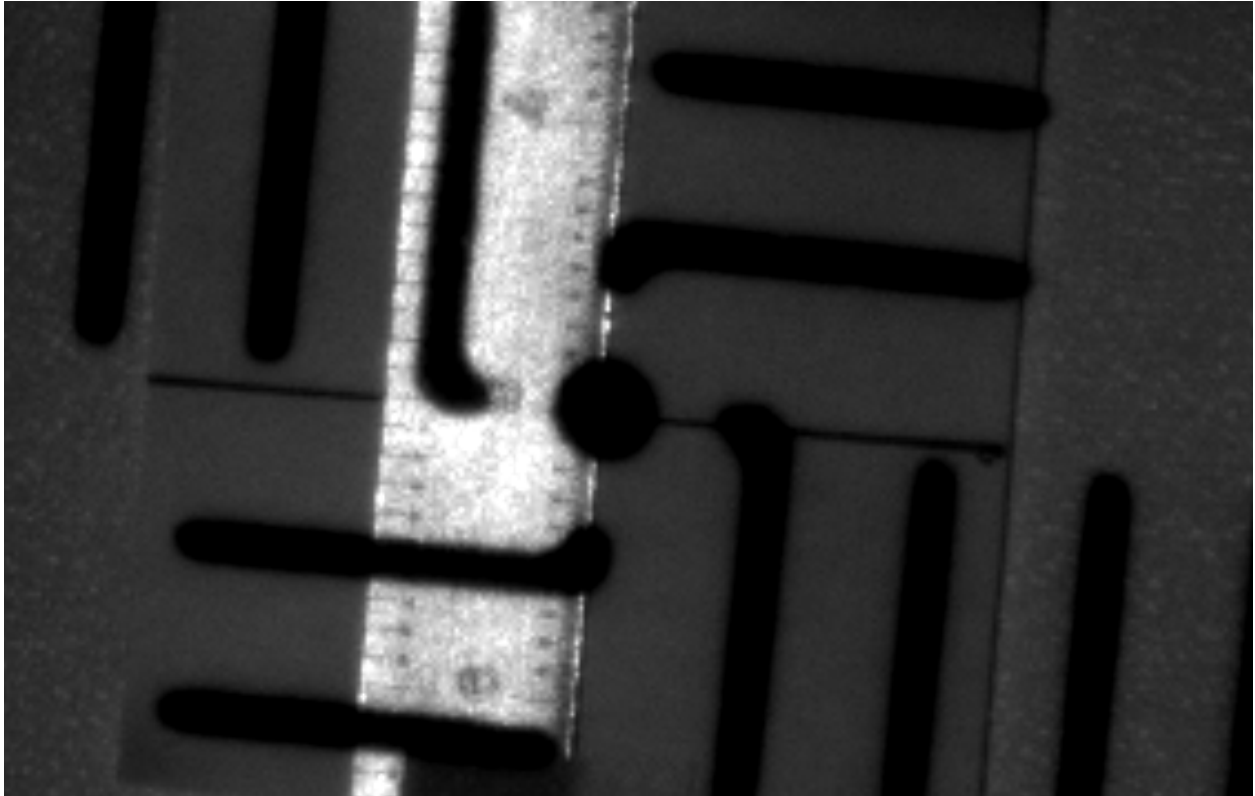


**Figure 3: Apparatus to test the projected reticle technique**

An image of the projection screen--containing a marked cross-hair, a calibrated machinists scale, and the green light projected image of the reticle from the alignment telescope--was captured with the CCD camera. The marks on the reticle are spaced 1 arc min, and the numbers on the scale indicate inches. The CCD camera image is shown in figure 4.

The observed resolution of the edges of the projected reticle was  $< 0.010$  inch, which is equivalent to an angular resolution of  $< 10 \times 10^{-6}$  rad. The resolution of the reticle image was limited by the pixilation of the CCD camera, which can easily be improved almost an order of magnitude simply by moving the camera closer to the screen. The diffraction limit of the 0.9 inch output aperture of the alignment telescope with 1060 nm light is approximately  $10 \times 10^{-8}$  rad. This implies that the limiting resolution of the reticle image is  $< 1 \times 10^{-4}$  inch at the 26 m distance of the projection screen, and the pointing accuracy of autocollimator is limited to  $< 10 \times 10^{-8}$  rad.

The experiment proved that the reticle projection technique can be used to align a target with a cross-hair to a fraction of a millimeter, and the autocollimator can be pointed to an accuracy of  $< 1 \times 10^{-6}$  rad.



**Figure 4: CCD image of the projection screen cross-hair with scale and projected reticle from the alignment telescope**

## **4 ALIGNMENT OF PO TELESCOPES**

The autocollimator mode will be used for the pre-alignment of the PO telescopes as well as for the final alignment and pointing on-site in the IFO.

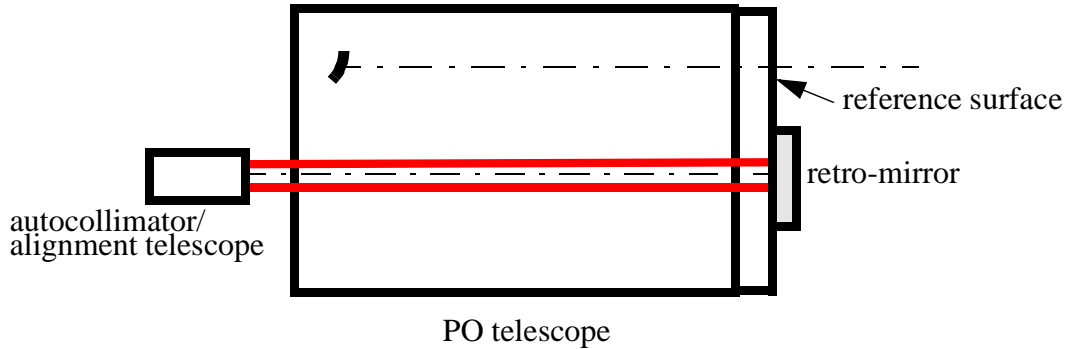
### **4.1. Pre-alignment of PO Telescope**

The prealignment of the PO telescopes will proceed in four steps.

#### **4.1.1. Alignment of PO Telescope Housing**

Step one is to remove the primary mirror with its mount and to set up the autocollimator perpendicular to the reference surface of the telescope housing by reflecting from the retro-mirror placed against the reference surface of the telescope, as shown in figure 5. Once this has been done, the telescope housing and the autocollimator will be locked down and will remain in fixed positions during the next two steps.

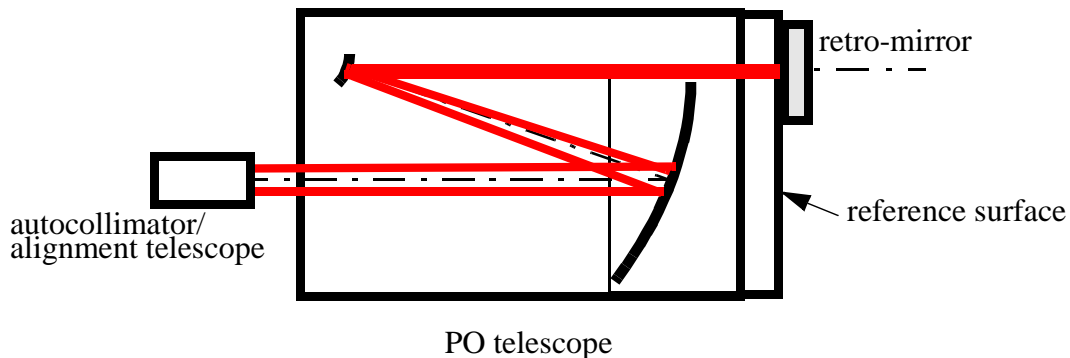




**Figure 5: Step one, alignment of PO telescope housing**

#### 4.1.2. Alignment of Optical Axis of PO Telescope

The second step, as shown in figure 6, consists of installing the primary mirror, placing the small retro-mirror against the reference surface at the output aperture of the telescope, and adjusting the secondary mirror position to bring the output beam perpendicular to the retro-mirror with an approximately plane wavefront. The perpendicularity is determined by nulling the displacement of the return image of the reticle as seen through the autocollimator eyepiece. The flatness of the wavefront is determined by sharpening the focus of the return image with the secondary mirror as much as possible.

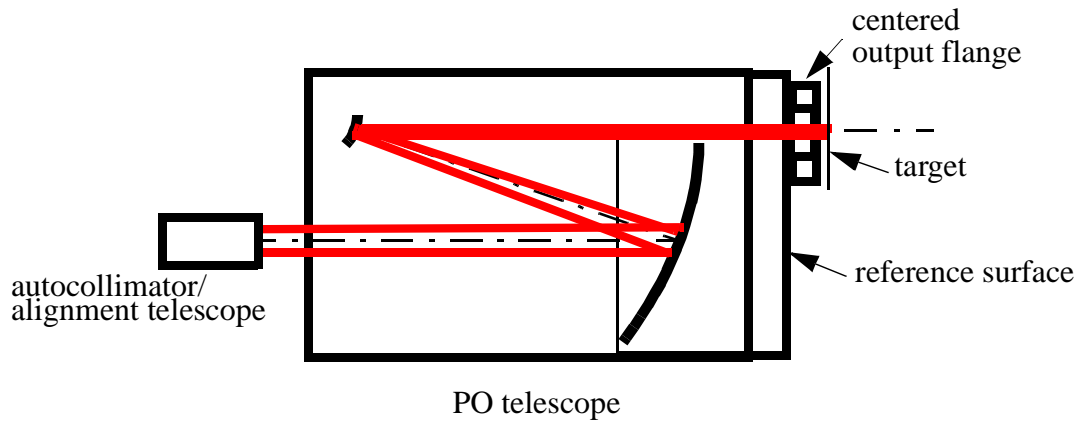


**Figure 6: Step two, alignment of PO telescope optical axis**

#### 4.1.3. Centering of PO Telescope Output Aperture

After the optical axis has been established in step two above, the output flange will be mounted to the reference surface and the alignment telescope will project a focussed alignment cross hair

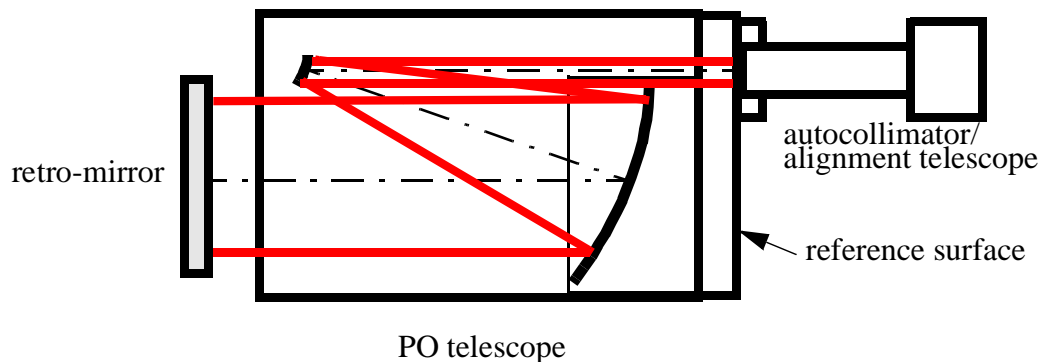
onto the target on the flange for centering with the optical axis of the PO telescope, as shown in figure 7.



**Figure 7: Step three, centering of the output flange with the optical axis**

#### 4.1.4. Full Aperture Alignment of PO Telescope

For the final step four, as shown in figure 8, the autocollimator will be moved to the output side of the telescope so as to fill the aperture of the telescope. The barrel of the autocollimator will be inserted into the pre-aligned output flange, which is perpendicular and on-axis with the reference surface. The large retro-mirror will be independently aligned perpendicular the autocollimator. Then, while maintaining the alignment of the telescope by nulling the autocollimator, the secondary mirror will be fine-adjusted to achieve the best focussed image of the reticle as seen through the eyepiece of the autocollimator.



**Figure 8: Step four, full aperture alignment of PO telescope**

## 4.2. On-site Alignment of the PO Telescope in the IFO

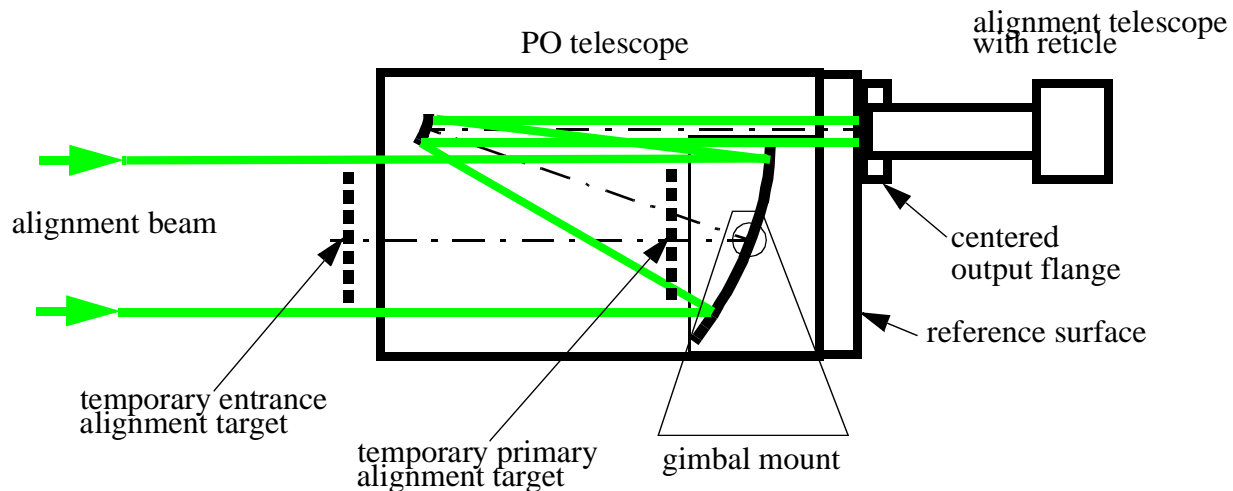
The pre-aligned PO telescope will be centered on the alignment beam by focussing the alignment telescope and projecting a cross-hair onto the entrance aperture of the PO telescope. Subsequently, the PO telescope will be pointed along the axis of the alignment beam by using the auto-collimating mode. Refer to figures 1, and 2.

### 4.2.1. Centering Alignment

The center of the primary mirror will be aligned with the axis of the alignment beam by moving the primary gimbal mount until the temporary alignment target placed near the primary mirror is centered on the focussed projected cross-hair image. Next, the entrance-end of the PO telescope will be aligned similarly by moving it until the temporary alignment target placed at the entrance-end of the telescope housing is centered on the projected cross-hair image. Then the primary gimbal mount is locked in place in the middle of its pitch and yaw adjustment range. Any further tilting of the telescope will pivot about the center of the primary mirror, maintaining the centering within the clear aperture.

### 4.2.2. Pointing Alignment

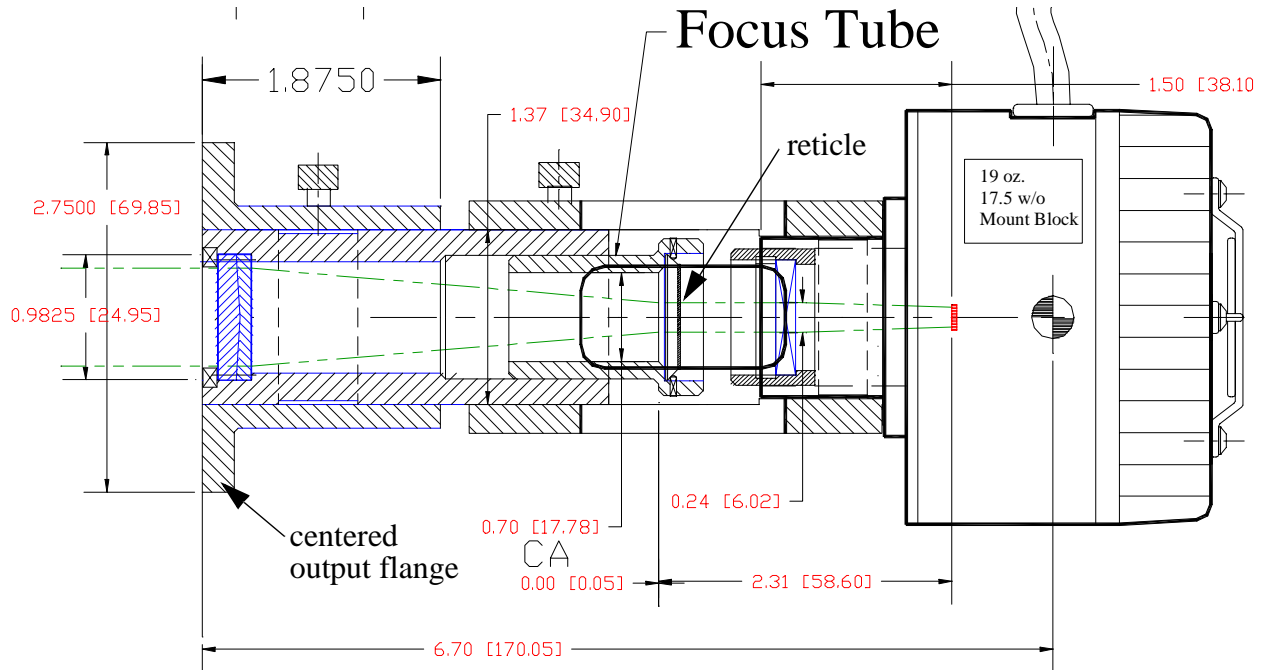
The alignment beam will be focussed at infinity. A second alignment telescope with a pre-centered reticle will be inserted into the output flange of the PO telescope, and the front end of the PO telescope will be tilted in pitch and yaw until the projected cross-hair image is nulled with the reticle of the alignment telescope, as shown in figure 9. The PO telescope is now completely aligned with the reference beam.



**Figure 9: On-site alignment of PO telescope in the IFO**

## 5 ALIGNMENT TELESCOPE MOUNTING FLANGE

A conceptual drawing of the alignment telescope mounted in the flange at the back of the PO telescope is shown in figure 10. The inside barrel of the flange is perpendicular to the mounting surface, which is the optical reference surface for the PO telescope. The flange will be centered with the output beam of the PO telescope by using the projected reticle technique described previously.



**Figure 10: Alignment telescope with IR CCD camera viewer**