

D1003349 AdLIGO AOS SR2 Scraper Baffle Clamped Assy (47.1mm), PART PDM REV: X-035, DRAWING PDM REV: X-010

NOTES CONTINUED:

- 5. APPROXIMATE WEIGHT = 32.92 LBS.  
APPROXIMATE WEIGHT WITH BLACK GLASS AND ASSOCIATED HARDWARE= 48.5 LBS.
- 6. PLEASE REFER TO LIGO D1500315 FOR BLACK GLASS ASSEMBLY INSTRUCTIONS.

REV.	DATE	DCN #	BOM #
v1	16 DEC 2011	E1000865	E1101210
v2	21 JAN 2016	E1600024-x0	-
-	-	-	-

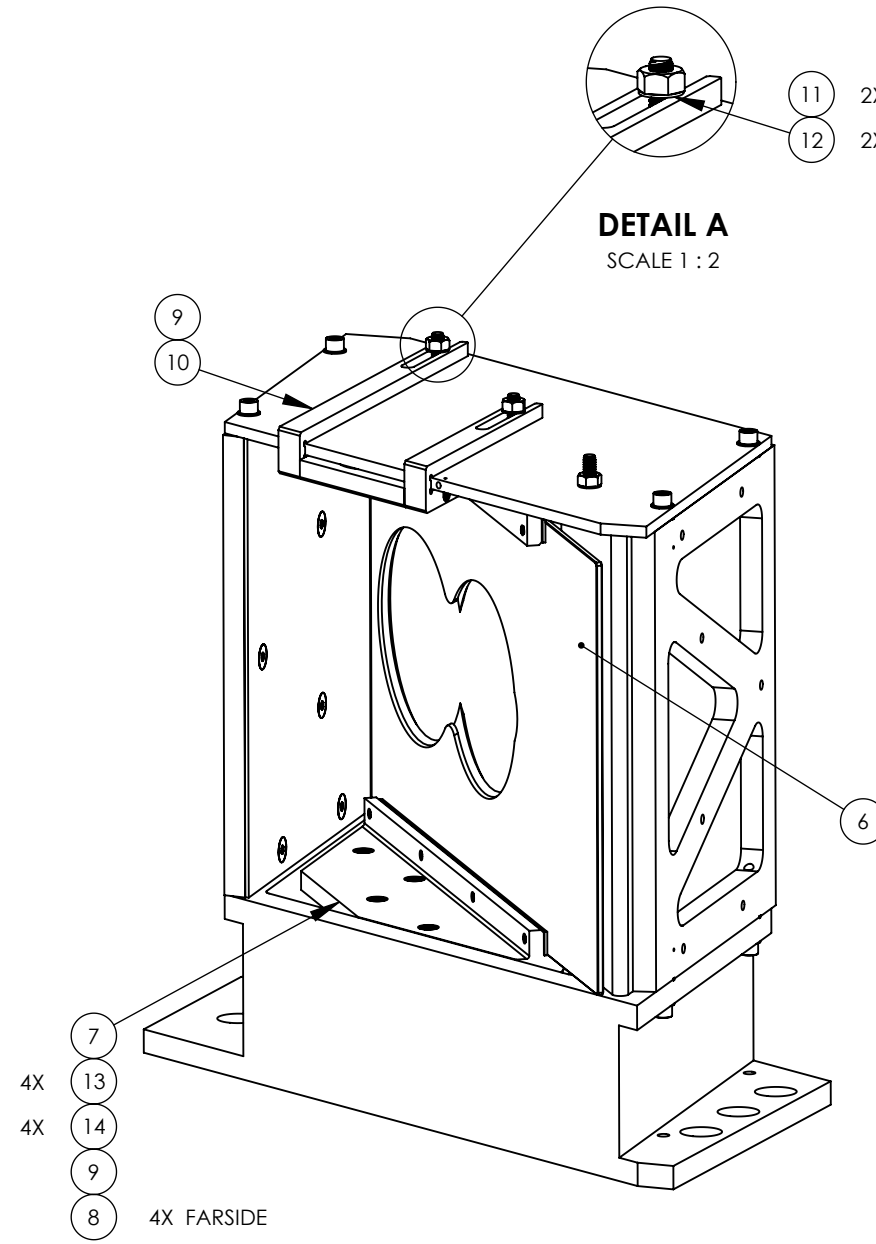
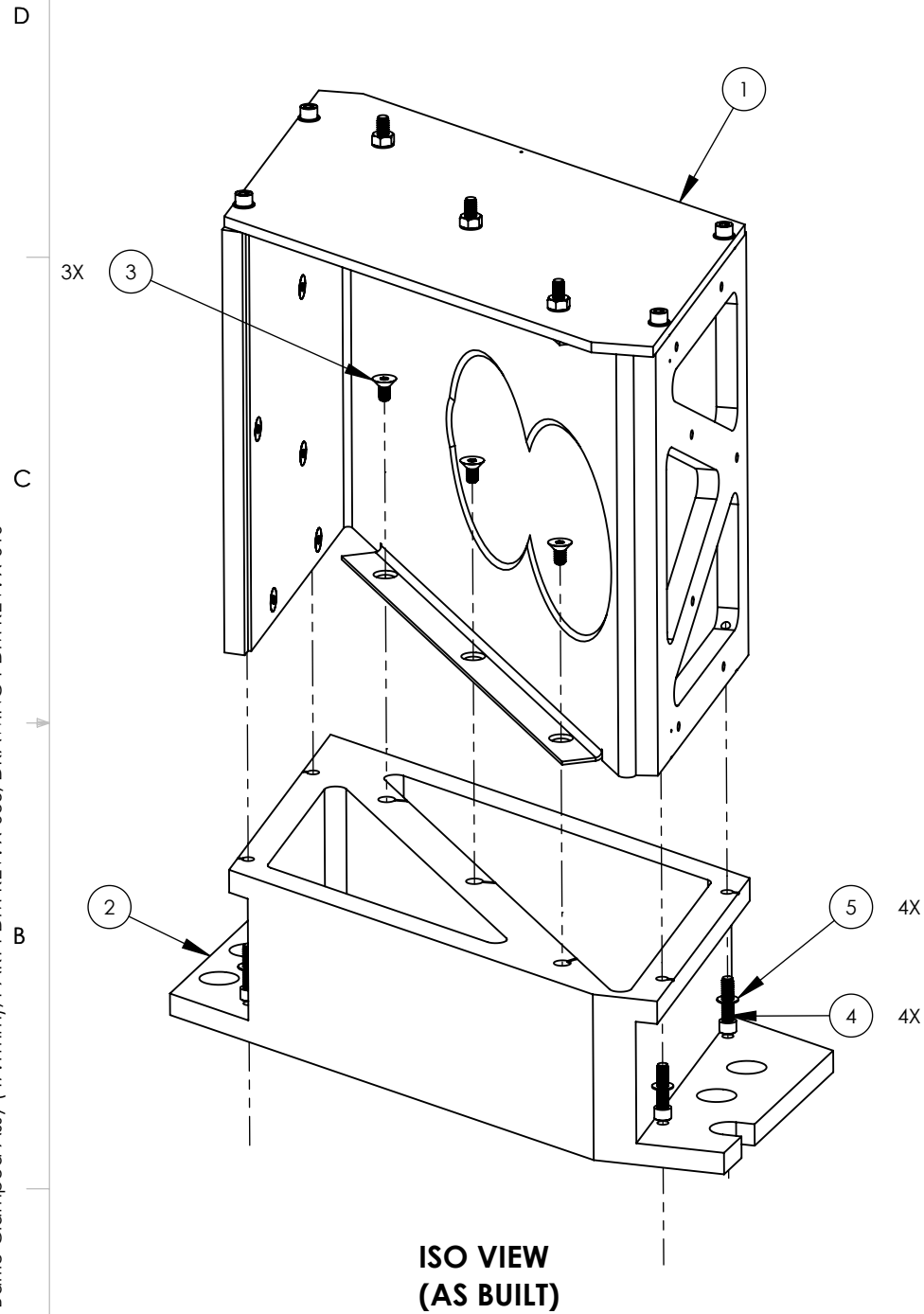



ITEM NO.	PART NUMBER	DESCRIPTION	MATERIAL	QTY
14	94355A192 McMASTER-CARR OR EQ.	SET SCREW, 8-32 X .38 LG.	18-8 SSTL	4
13	MS16995-49 OR EQ.	SCREW, SHC, 1/4-20 X .63 LG.	300 SSTL	4
12	WF-25 UC COMPONENTS OR EQ.	FLAT WASHER 1/4 SCREW SIZE	18-8 SSTL	2
11	N-2520-A	HEX NUT, 1/4-20 THRD SIZE	Ag-PLATED 300 SSTL	2
10	D1600016	aLIGO, AOS, SR2 Scraper Baffle, BK glass overlay, Support Assy.	AS NOTED	1
9	D1600012	aLIGO, AOS, SR2 Scraper Baffle, BK glass overlay, Shim	PEEK	2
8	D1600017-101	aLIGO, AOS, SR2 Scraper Baffle, BK glass overlay, 1/4-20 M/F standoff (2.5 Lg.)	6061-T6 Al	4
7	D1600011	aLIGO, AOS, SR2 Scraper Baffle, BK glass overlay, Support (Bot)	PEEK	1
6	D1600003	aLIGO, HAM4, SR2 SCRAPER BAFFLE, BK GLASS OVERLAY	BK7 GLASS	1
5	90945A760	1/4 X .47OD X .02-.04THK NAS 620 FLAT WASHER	300 SSTL	4
4	92200A542	SCREW, SHC, 1/4-20 x 1, MS16995-52, MC #92200A542	300 SSTL	4
3	94518A510	Flat, SHCS, .25-20 x .50 lg. (MS24671-28)	300 SSTL	3
2	D1100366	SPACER, SR2 SCRAPER BAFFLE, L1	6061-T6 Al	1
1	D1003300	SR2 SCRAPER BAFFLE SKIN ASSY	N/A	1

PARTS LIST

NOTES AND TOLERANCES: (UNLESS OTHERWISE SPECIFIED)				LIGO CALIFORNIA INSTITUTE OF TECHNOLOGY MASSACHUSETTS INSTITUTE OF TECHNOLOGY				PART NAME SR2 Scraper Baffle Clamped Assy, L1					
MATERIAL	N/A	FINISH	N/A μinch	SYSTEM	ADVANCED LIGO	SUB-SYSTEM	AOS	DESIGNER	MRUIZ	19 DEC 2011	SIZE	DWG. NO.	REV.
				NEXT ASSY	D1101474			DRAFTER	J. TERRAZAS	15 DEC 2011	B	D1003349	v2
								CHECKER	M. SMITH	17 MAY 2012	SCALE: 1:4	PROJECTION:	SHEET 1 OF 2
								APPROVAL	M. SMITH	17 MAY 2012			

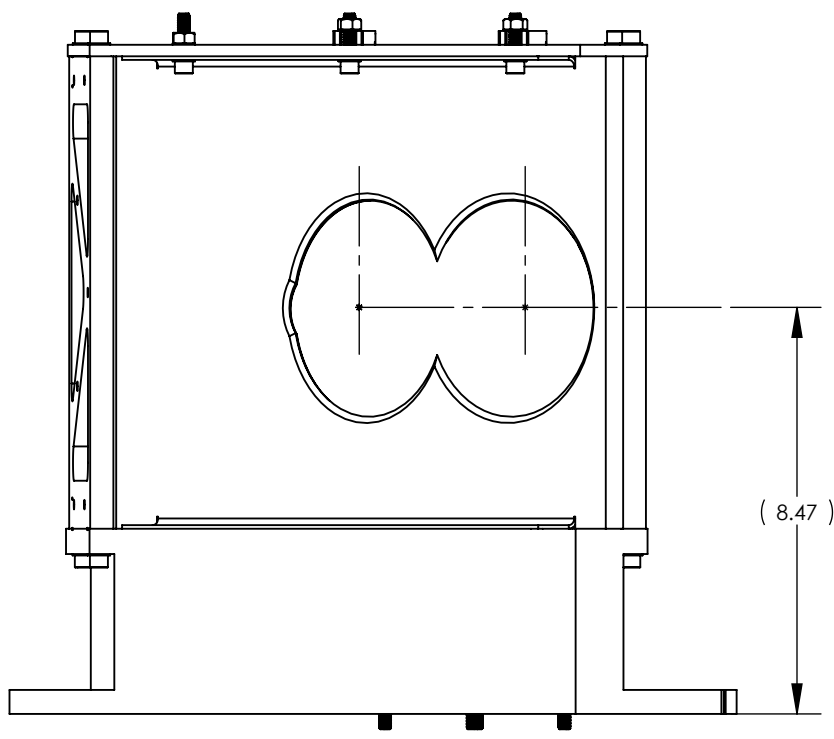
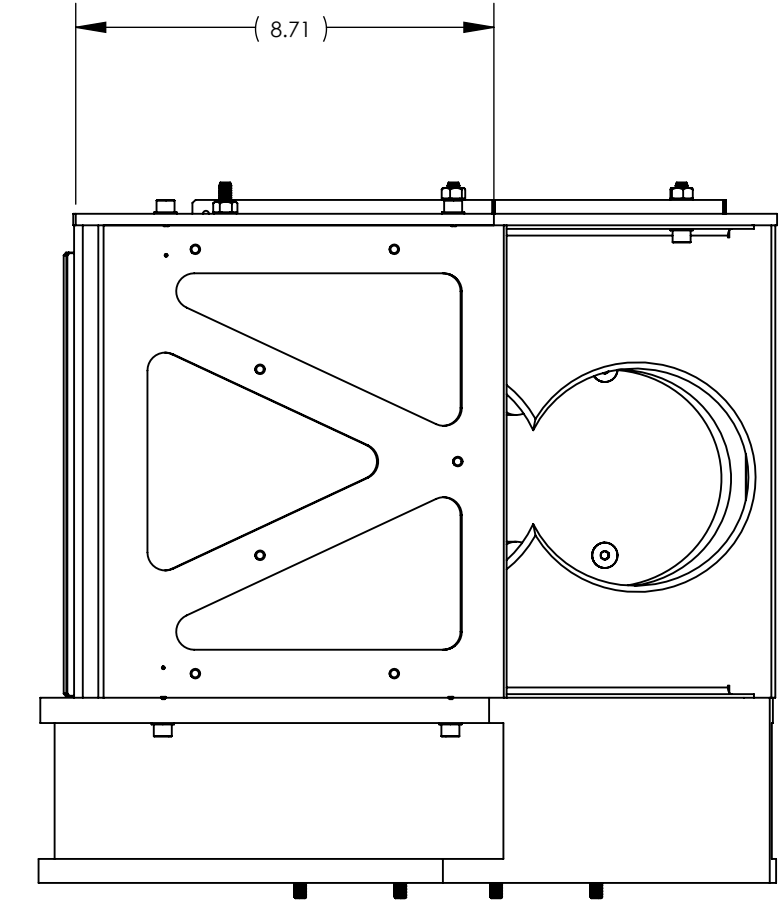
D1003349 AdLIGO AOS SR2 Scraper Baffle Clamped Assy (47.1mm), PART PDM REV: X-035, DRAWING PDM REV: X-010



 <b>CALIFORNIA INSTITUTE OF TECHNOLOGY</b> <b>MASSACHUSETTS INSTITUTE OF TECHNOLOGY</b>		
SIZE	DWG. NO.	REV.
<b>B</b>	D1003349	v2
SCALE: 1:8	PROJECTION:	SHEET 2 OF 2