

Precipitation hardened steel

ESTIMATION OF RESIDUAL CREEP

With Maraging observe the creep speed
to increase x 30 for 10°C rises

Bake blades under stress at $\geq 80^\circ\text{C}$ for a week

Observe creep at $< 1 \mu\text{m} / \text{day}$ @ 80°C

Observe creep at $< 50\text{-}100 \text{ nm} / \text{day}$ @ 65°C

Estimate residual creep at $< 1 \text{ nm} / \text{day}$ @ 20°C

1 Crystal slippage / day

Most residual creep may be due

to pure dislocations

(slippage under threshold)

Non Stochastic Noise (NSN) sources

all sources that inject energy

in the interferometer

in a non controlled non thermal mode

Generate events

outside the exponential noise distribution.

A) Internal sources

B) Couplings to outside world

NSN Sources

A) INTERNAL

Creep noise on wires and springs

Thermal movement noise and upconversions

Cabling problems

mechanical noise

contact noise

triboelectricity noise

•

B) EXTERNAL COUPLINGS

•

•

•

Active Attenuation
and mode damping

Passive Attenuation

Optical
Elements

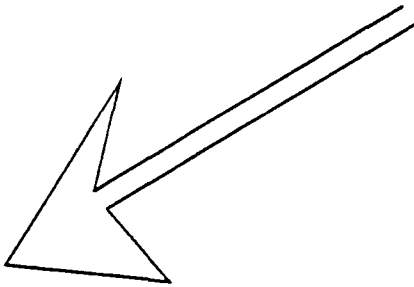

Internal
excitation

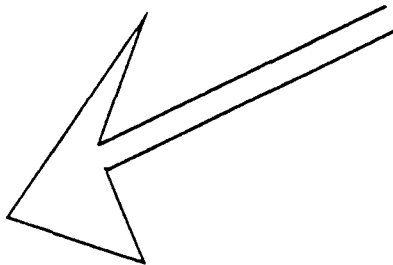

External
excitation

Creep noise

CAUSE

Dislocations inside single crystals

accumulate stress on

Crystal border impurities

EFFECT

Eventually will exceed stress yield point

all crystals will slip

OBSERVABLE (MACROSCOPICALLY)

Integrated continuous motion.

OBSERVABLE (MICROSCOPICALLY)

JERKING MOTION

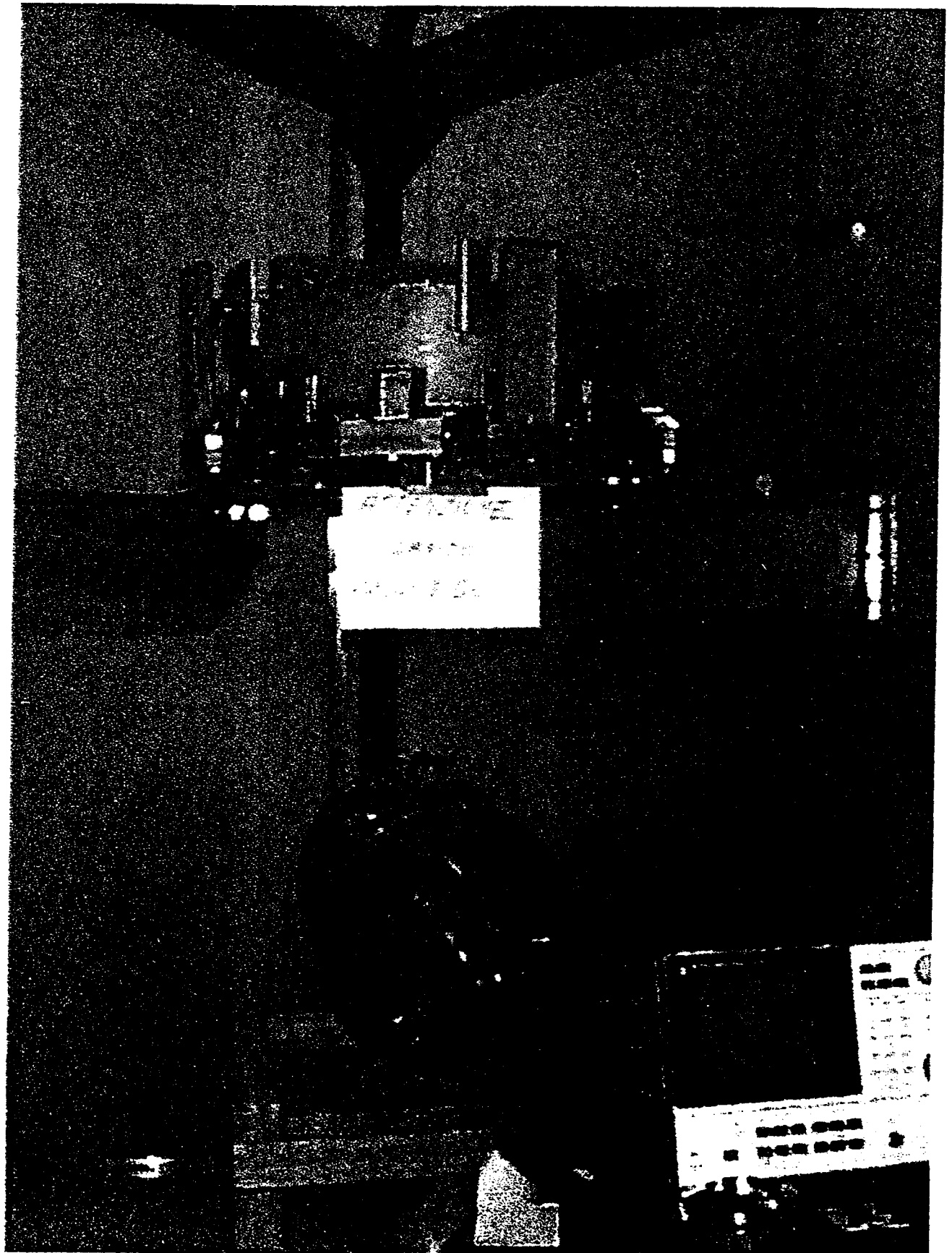

Creep noise

Energy releases in the S.A. chain

can generate nano-seisms

Suspended masses are inexhaustible reserve of energy

Consider Crystal slippage

$$\sim 10^{-9} \text{ J}$$

one single Crystal stressed near the metal yield point of the metal contains (and releases at slippage) energy equivalent to the dropping of the suspended optical component by several pm

A pico-meter is a **Mega-nano-nano-meter**

It's the "**big one**"



WE WILL GO
INSIDE ONE
OF THESE
5 μm
CRYSTALS

the creep noise mechanism

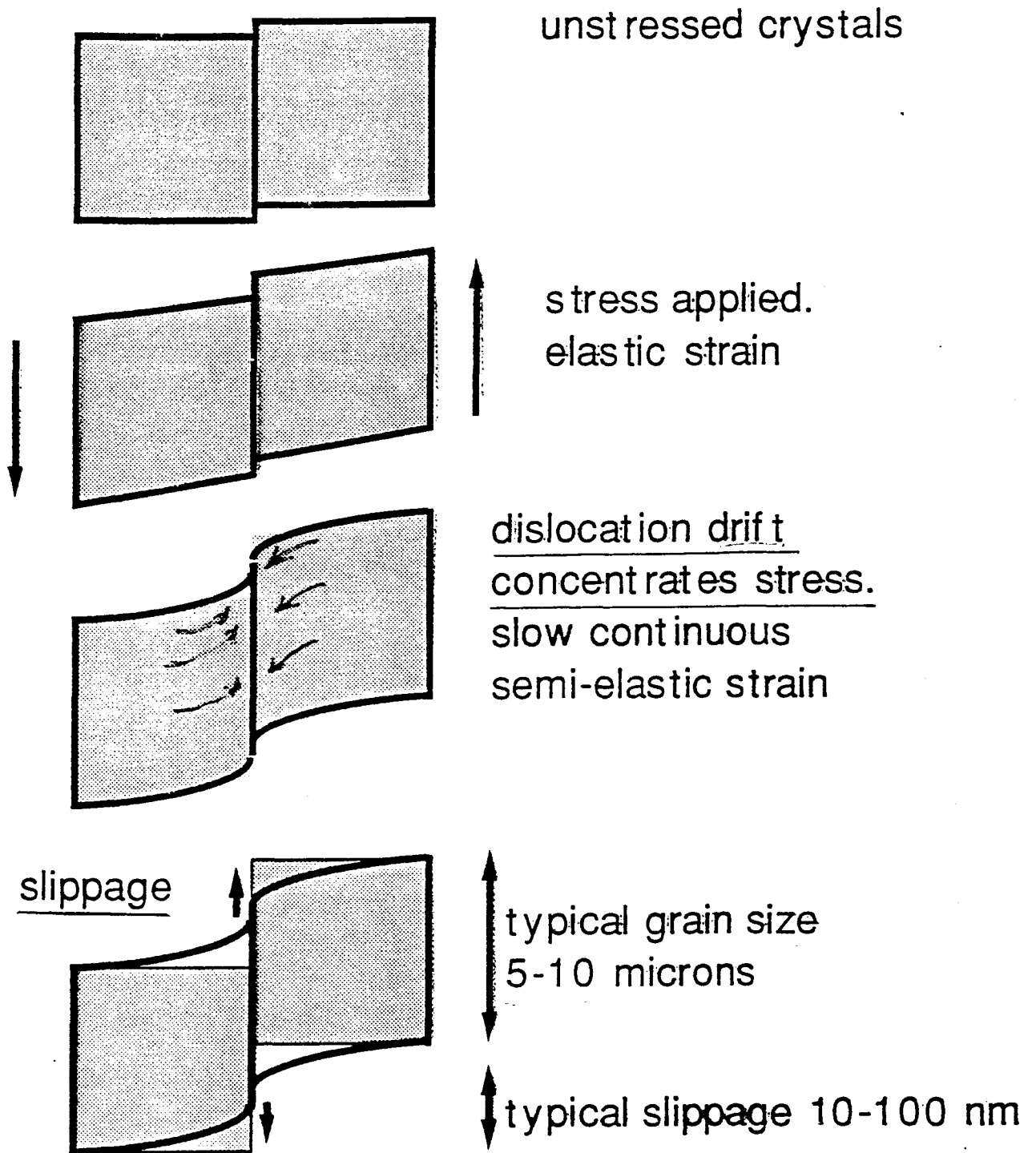

ACOUSTIC NOISE MEASUREMENTS

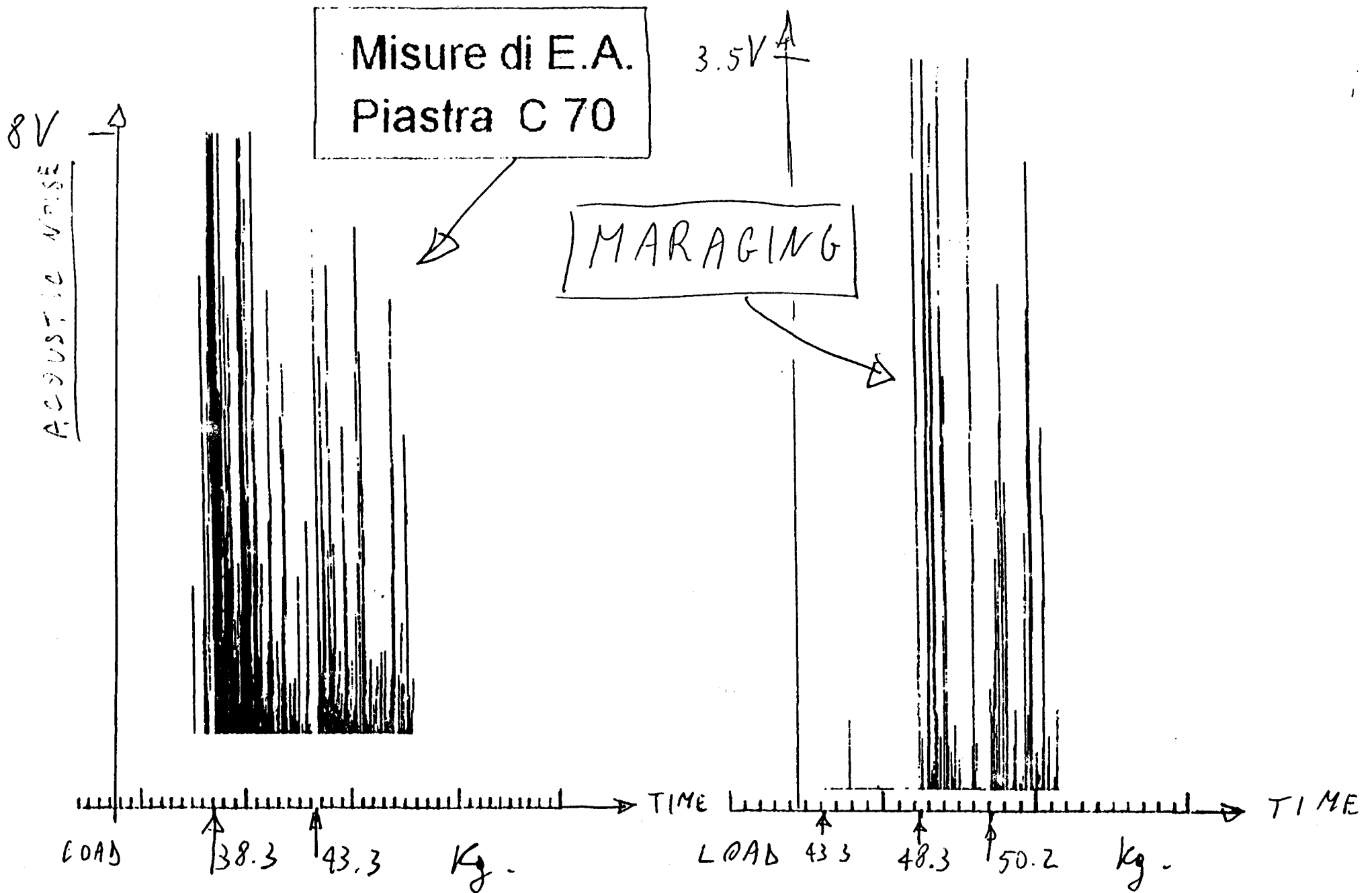

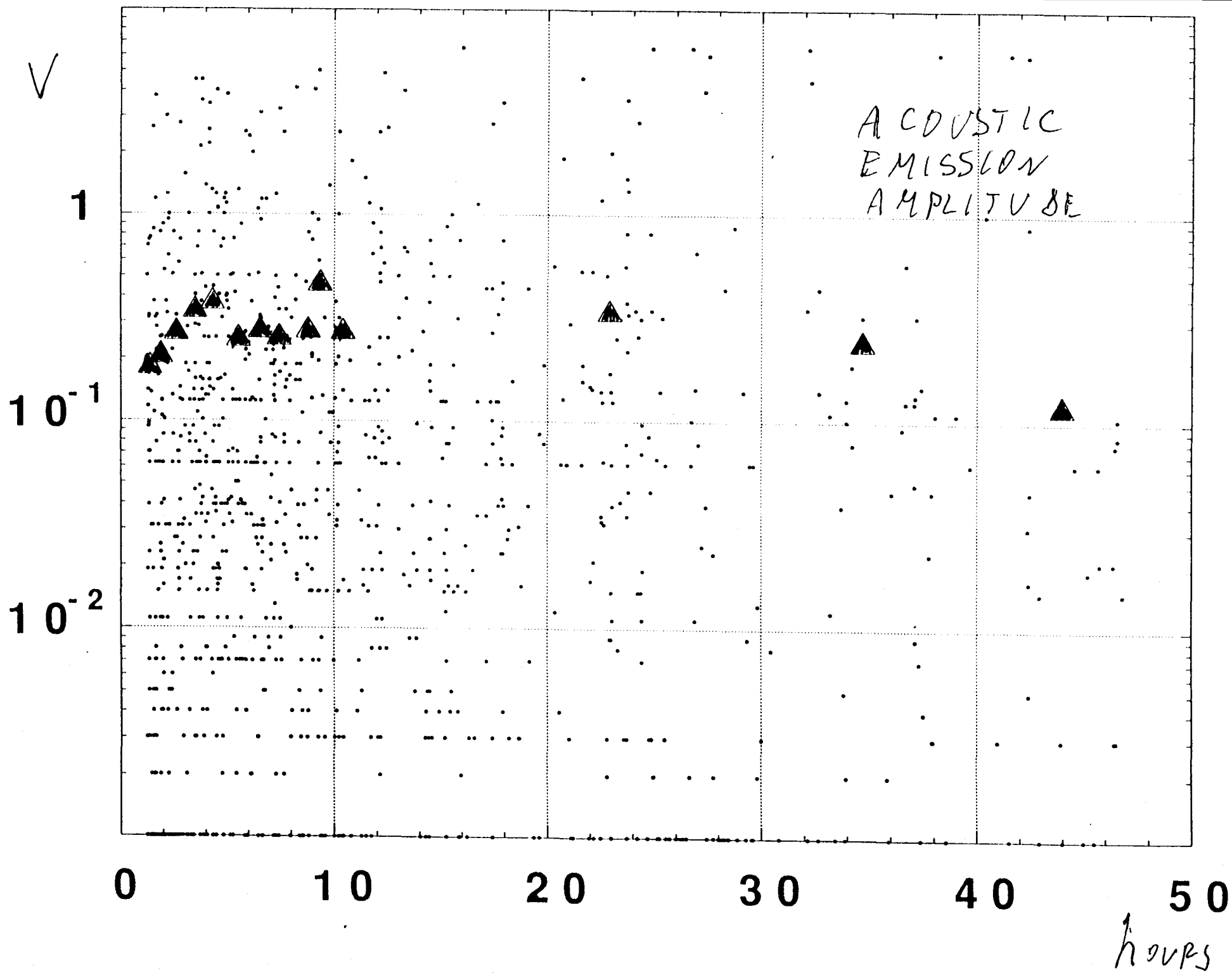

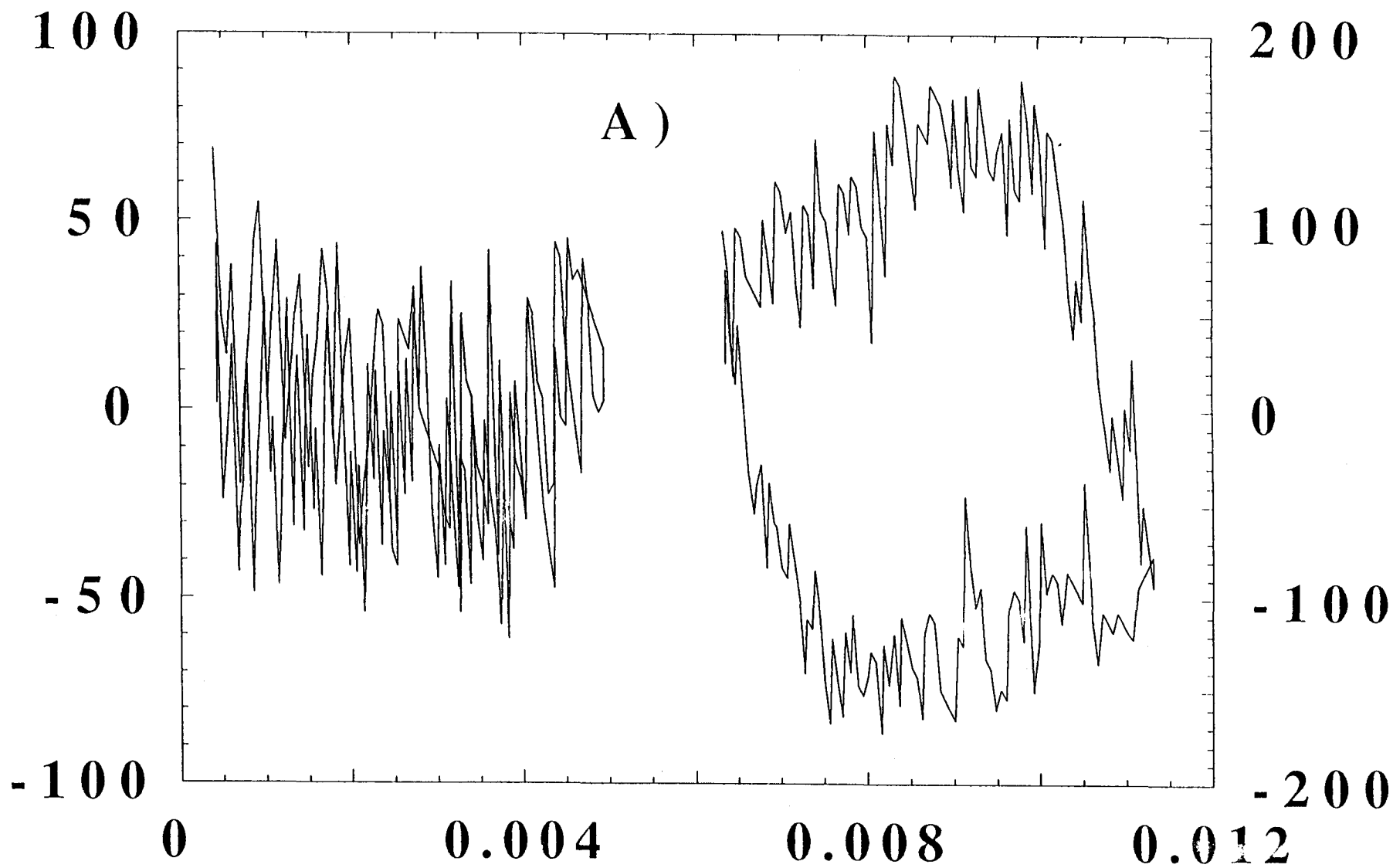

TIME BETWEEN A. E. EVENTS

SECONDS

10^3

10^2

10

1

0

10

20

30

40

50

hours

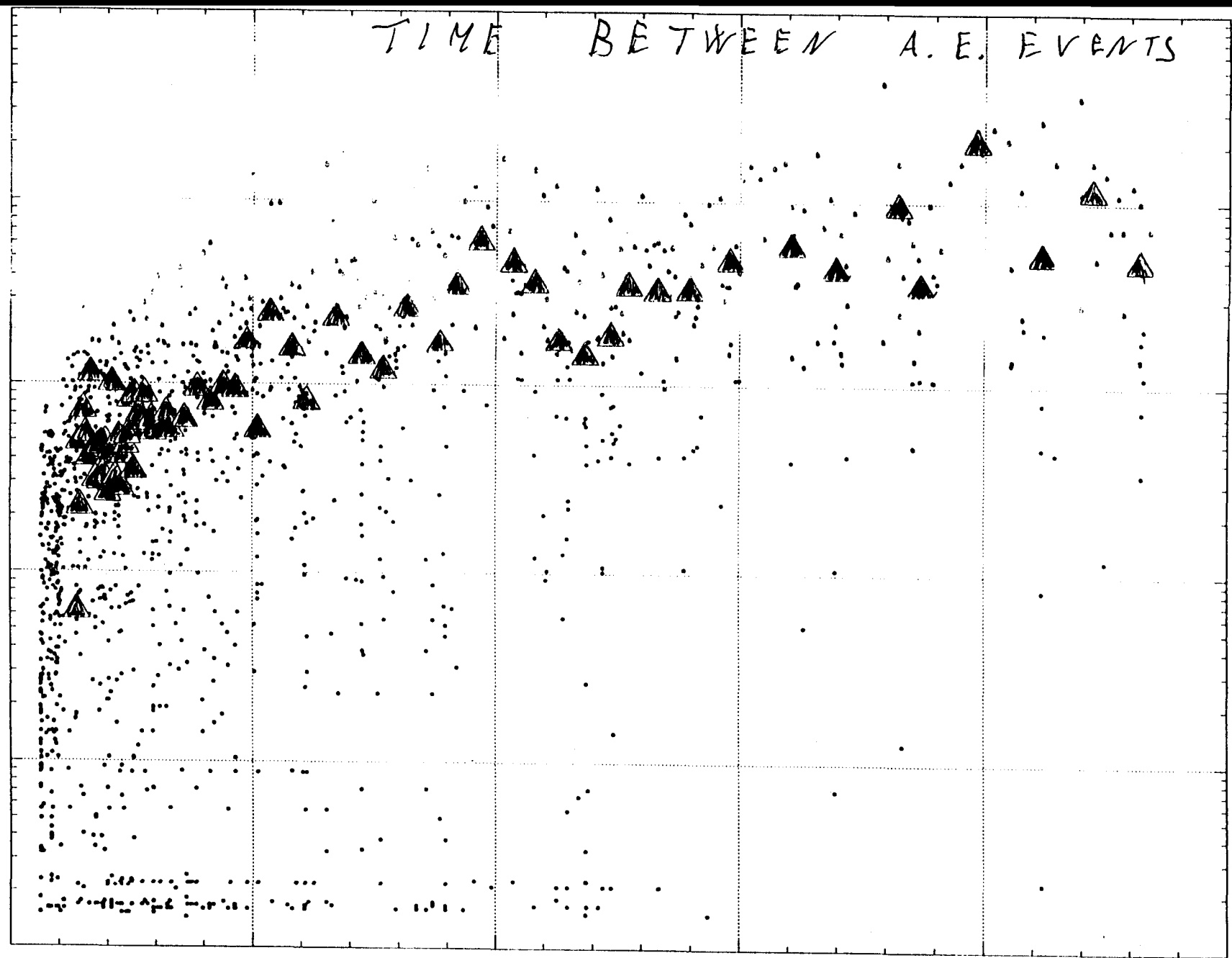

12000

120000

8000

80000

4000

40000

0

0

0

100

200

300

B)

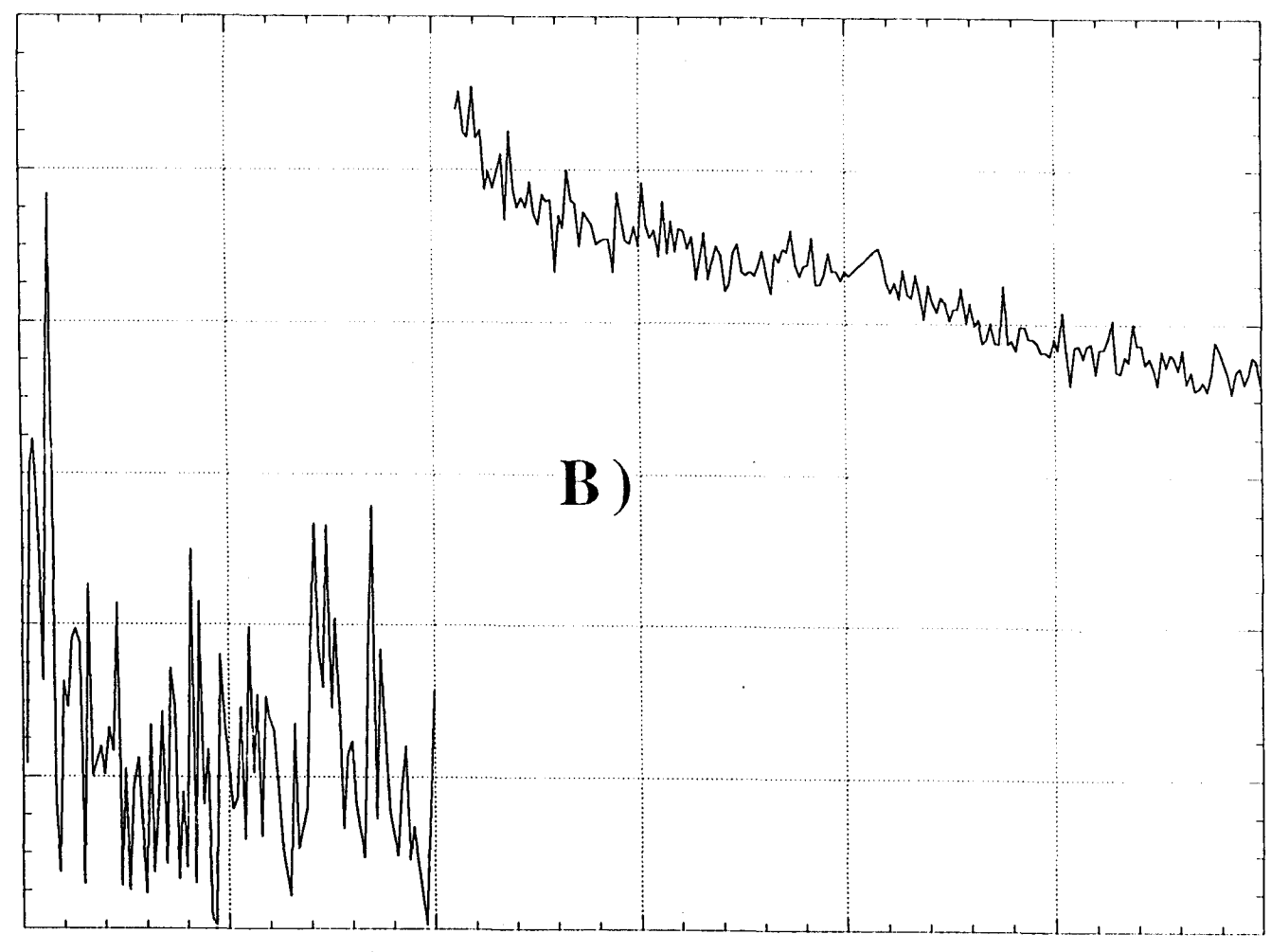

NEED TO ELIMINATE

THE SOURCE OF SLIP

NEED TO STOP THE

DISLOCATIONS !!

Creep noise

The only ways out are:

a) Infinitely small crystals

(gain with d^3 but unfeasible)

b) frozen crystals

b1) freeze by cooling

b2) chemical freezing

Creep noise

Dislocations have activation energies
of few Kcal/mole

$$\text{Freq.}_{\text{slippage}} = \underline{n} \underline{e^{\frac{\Delta E}{kT}}} \text{ (Bq)}$$

Creep Speed **x 10** for $\Delta T = 5 - 20^\circ\text{C}$

Creep speed is controlled by the temperature

AISI 1070 blade creep vs temperature

β CREEP
(CONTINUOUS)

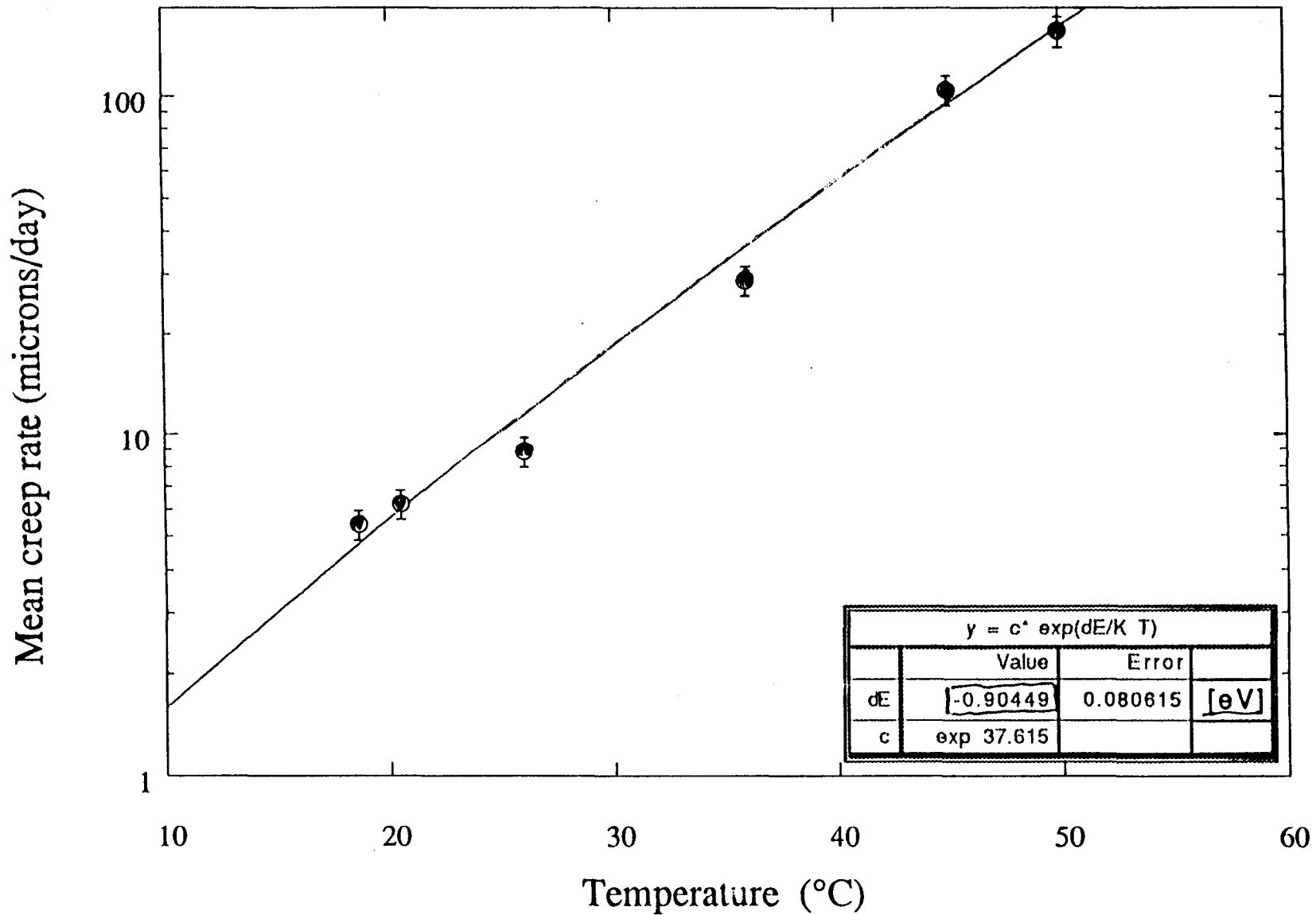

Creep noise

Freezing crystals by cooling

Metal brittleness

Spontaneous fracture

freeze only high ΔE dislocations

low ΔE dislocations can still move and
generate catastrophes

Risolubilised State

○ Fe

● Co

● Ti

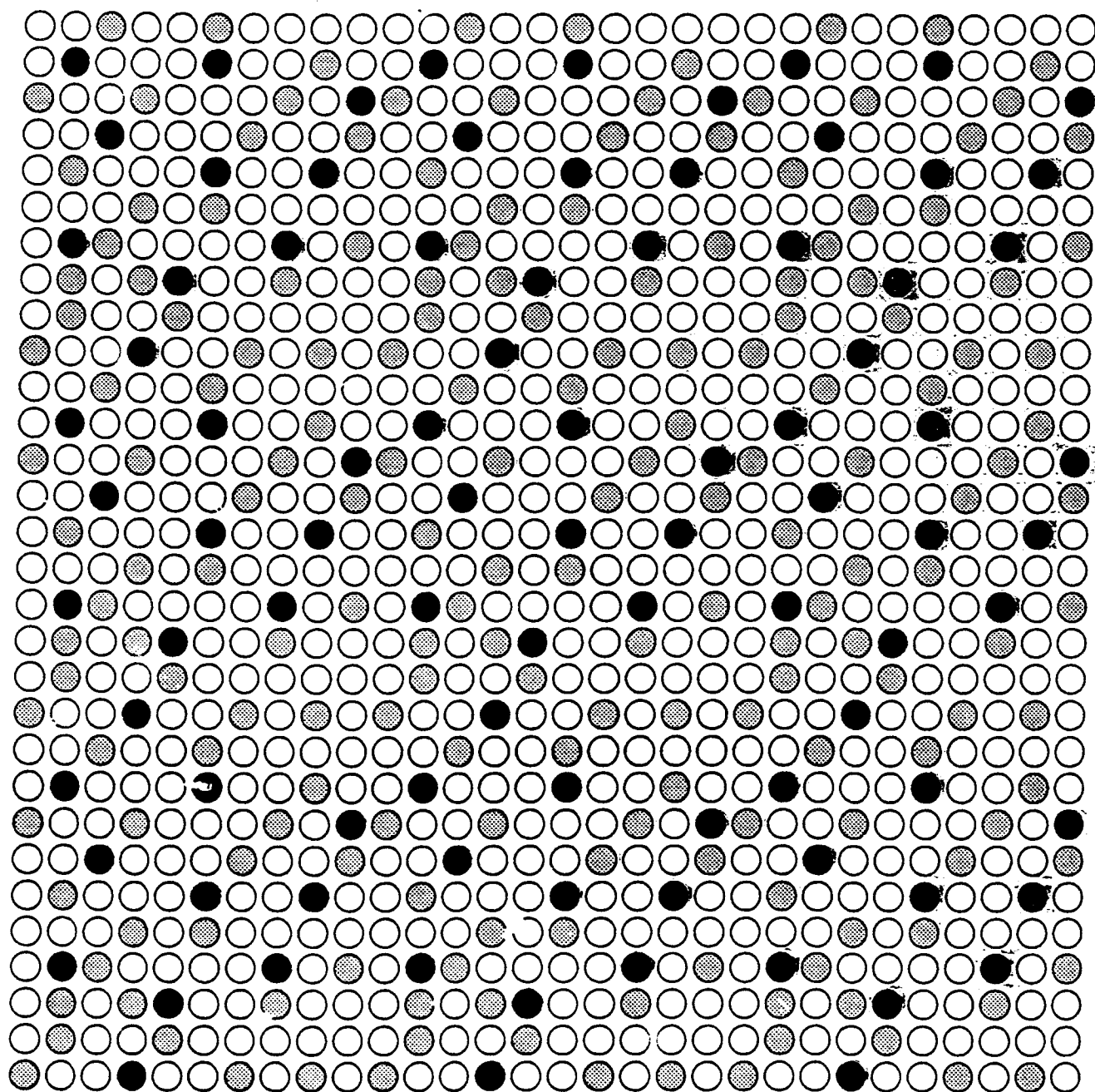

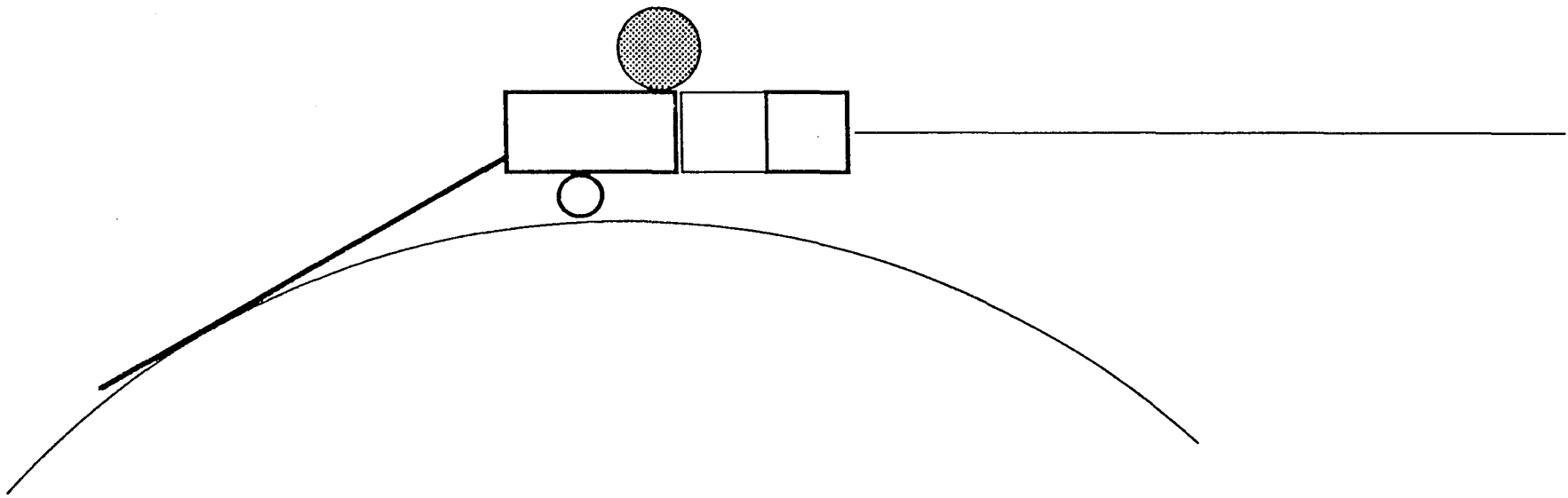

Risolubilised State

○ Fe

◐ Co

● Ti

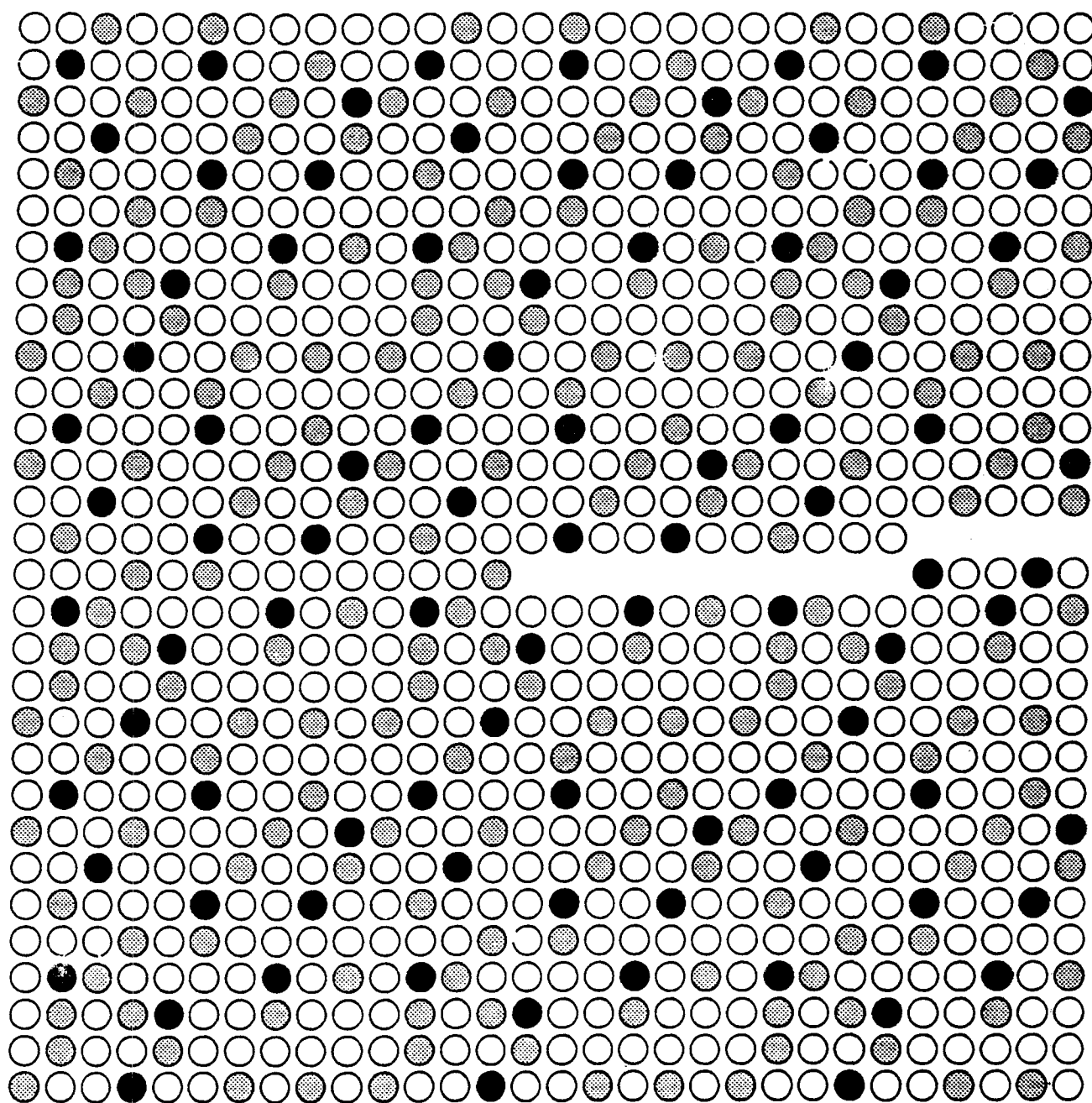

Creep noise

Chemical freezing of crystals

Precipitation hardened steel

Maraging

Fe + Co + Ni + Ti
5.5% 20% 10% 4%

High purity (no precipitation centers)

- Solution stable in Fusion

- Solid solution stable at > 850°C

- Solid solution thermodynamically unstable < 450°C
in 10^{many} years would precipitate

Ti-Co nano-crystals inside Fe crystals

Precipitation hardened steel

Precipitation process is impeded
at room temperature
by lack of Co and Ni diffusion
inside Fe crystals

Solubilised form metastable at 20°C

At 450°C Fe Crystal are still stable but

Co, Ti, Ni atoms can diffuse

typical diffusion distance 30 nm

Every 30 nm a nano-crystal forms inside the
otherwise un-perturbed Fe Crystal

about 10⁶ nano-crystals/Crystal

Precipitated State

○ Fe

◐ Co

● Ti

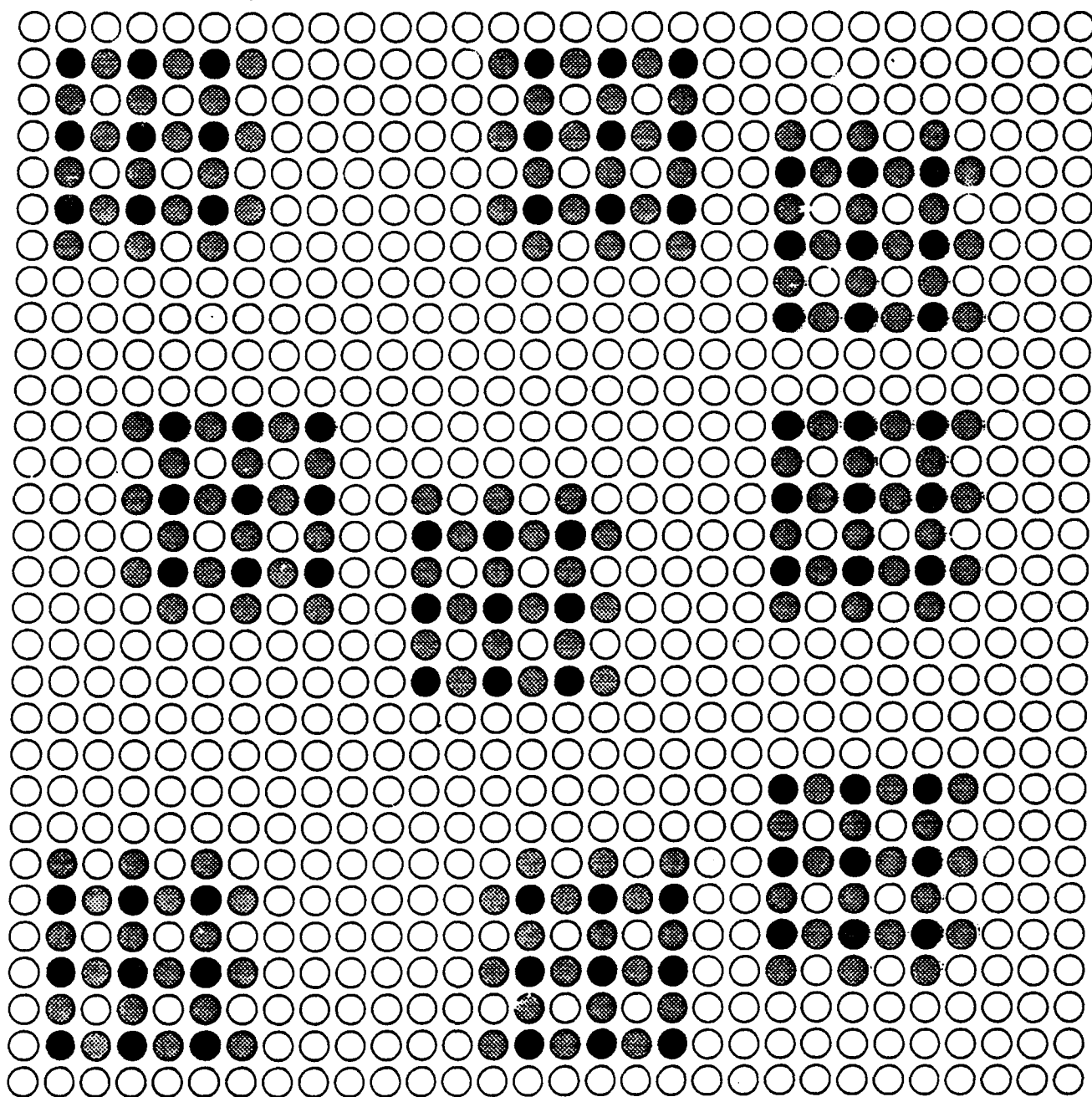

Precipitation hardened steel

Nano-crystals inside crystals

form dislocation drift barriers

Dislocations are trapped throughout the Crystal

Dislocations impeded to reach the Crystal border

cannot trigger Crystal slippage

creep stops ! ! !

R. DeSalvo Amaldi conference 2/5 July 1997

Precipitated State

○ Fe

● Co

● Ti

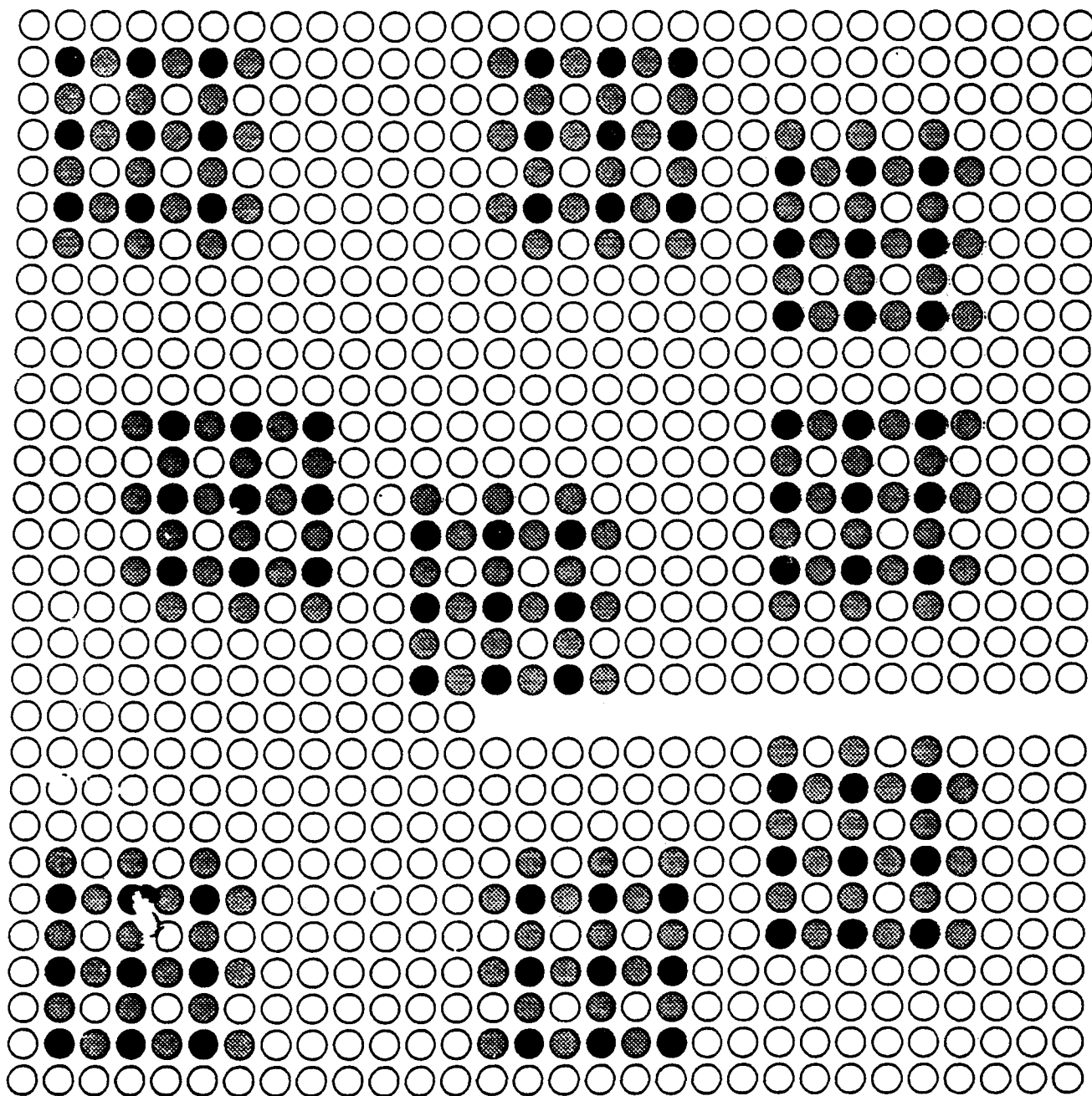

Precipitation hardened steel

After precipitation hardening,

∝ CREEP

creep shows logarithmic behavior vs. t .

Given our measurement errors creep

can be directly measured at $< 50-100$ nm/day

Need an indirect measurement.

Need to guarantee much lower

creep level

35

Blade a2 test

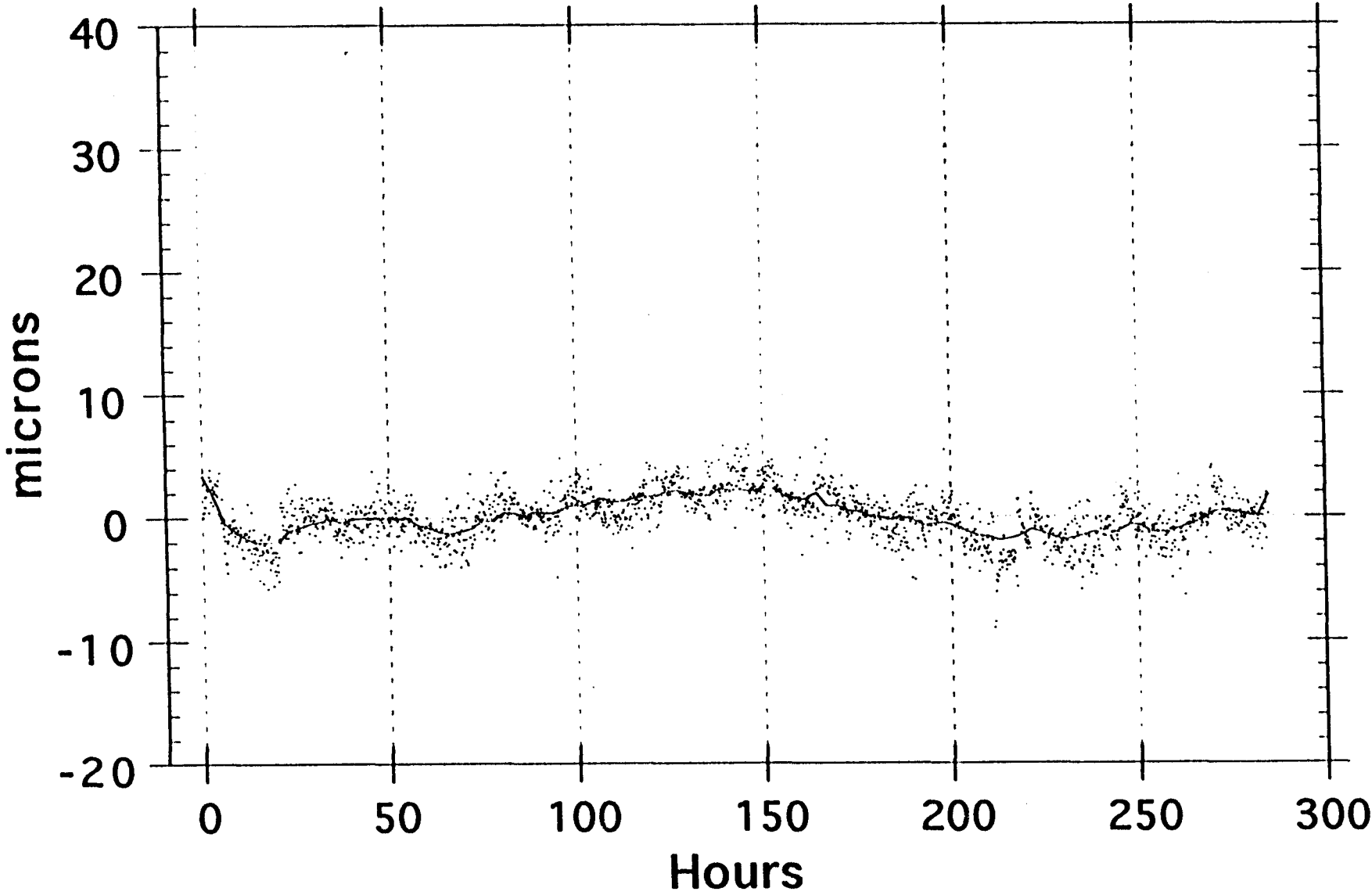

MARAGING VS C70 @ 50 C (preliminary)

CREEP RATES:
-0.06±0.01 microns/hour for Maraging
-5.0±0.5 microns/hour for C70

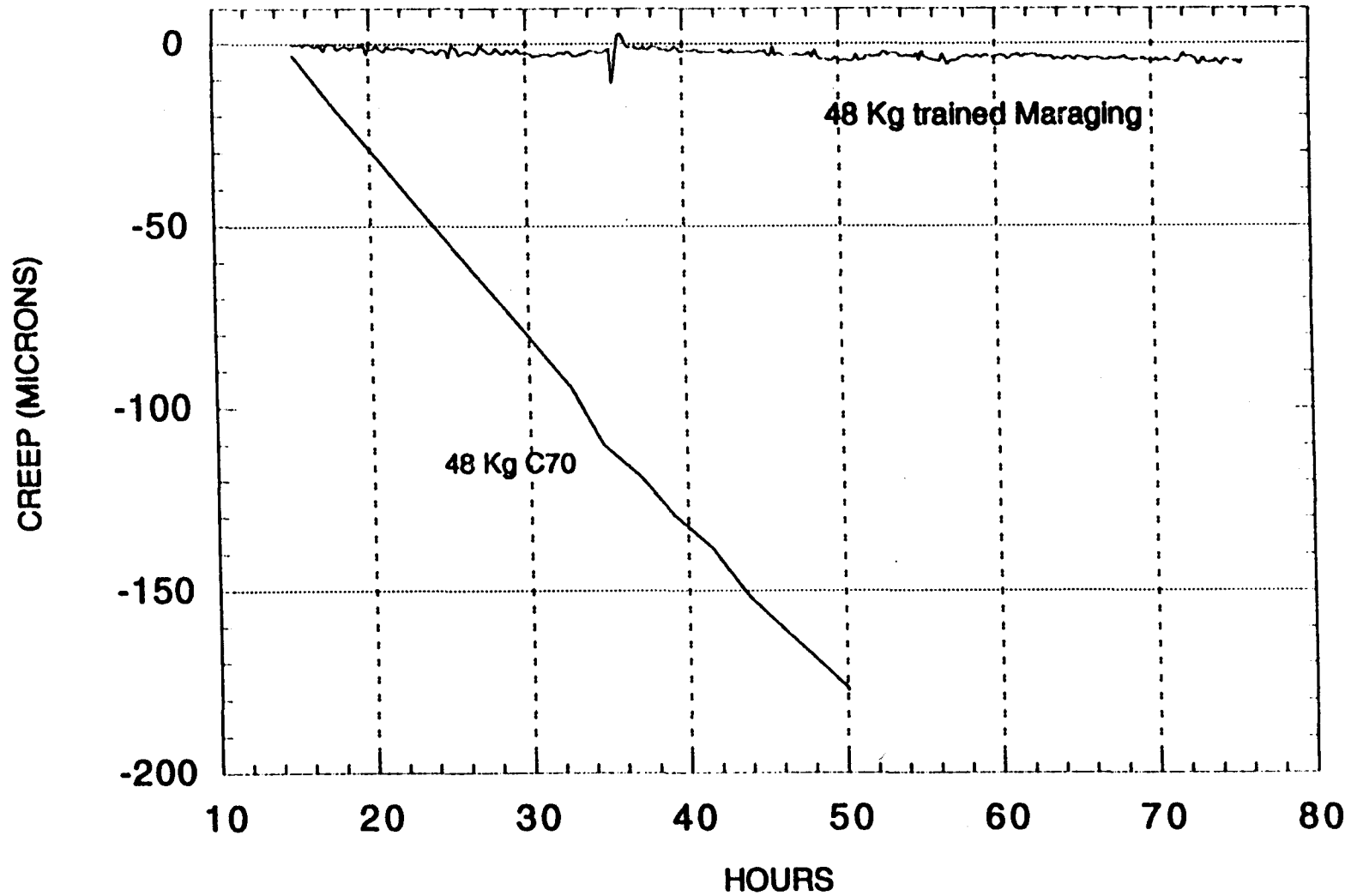

— 50

Blade a2 test

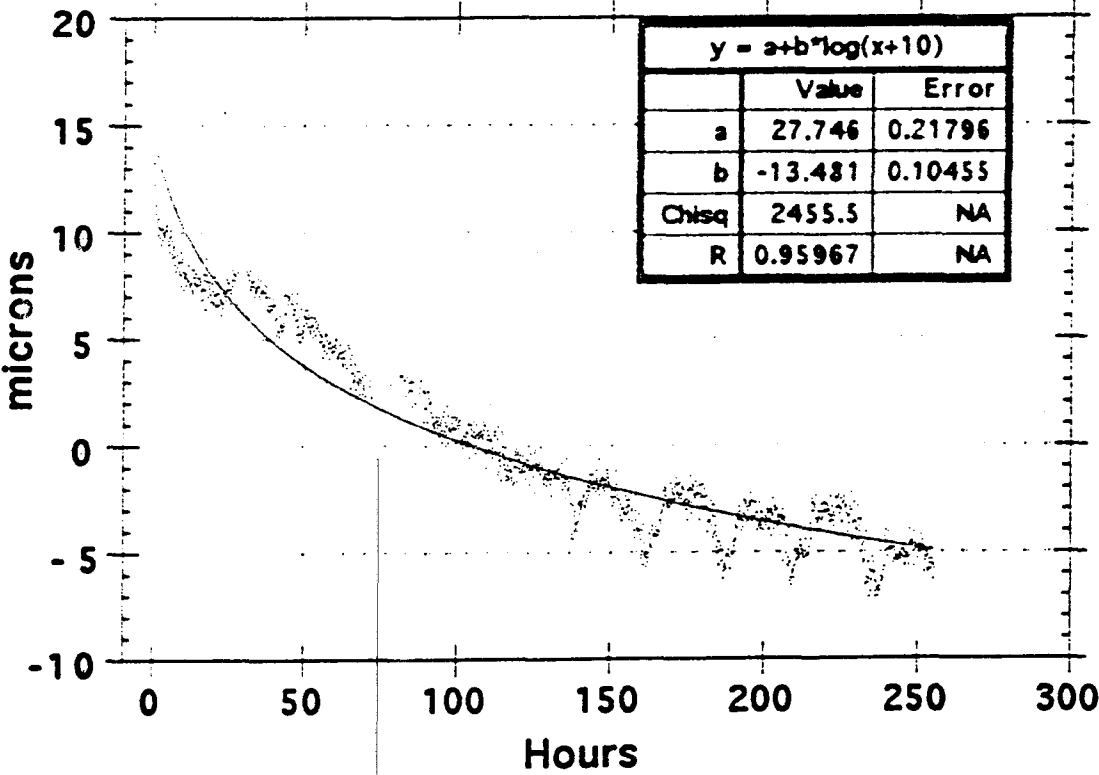

Blade a2 test

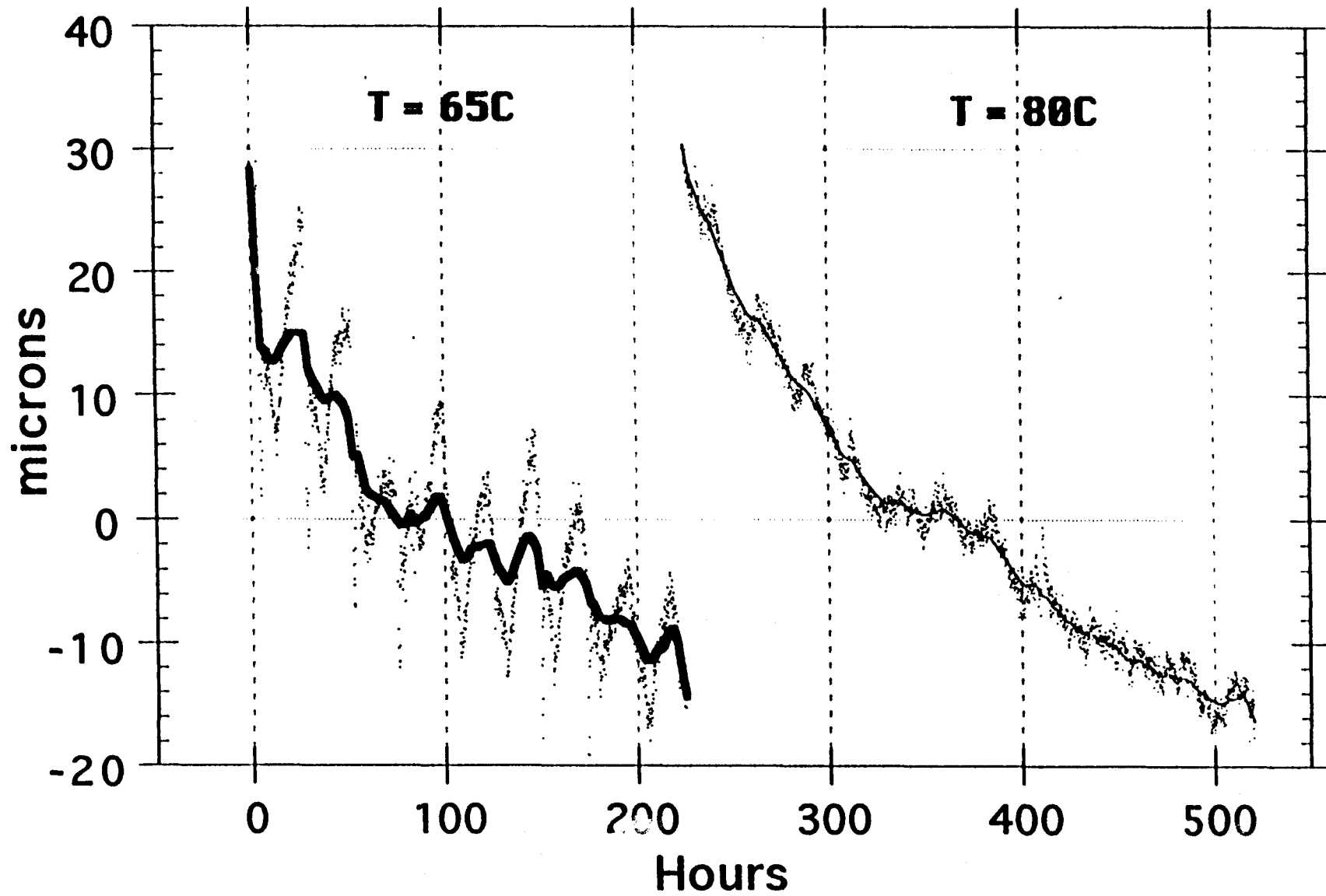
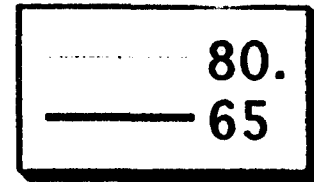

Blade a2 test

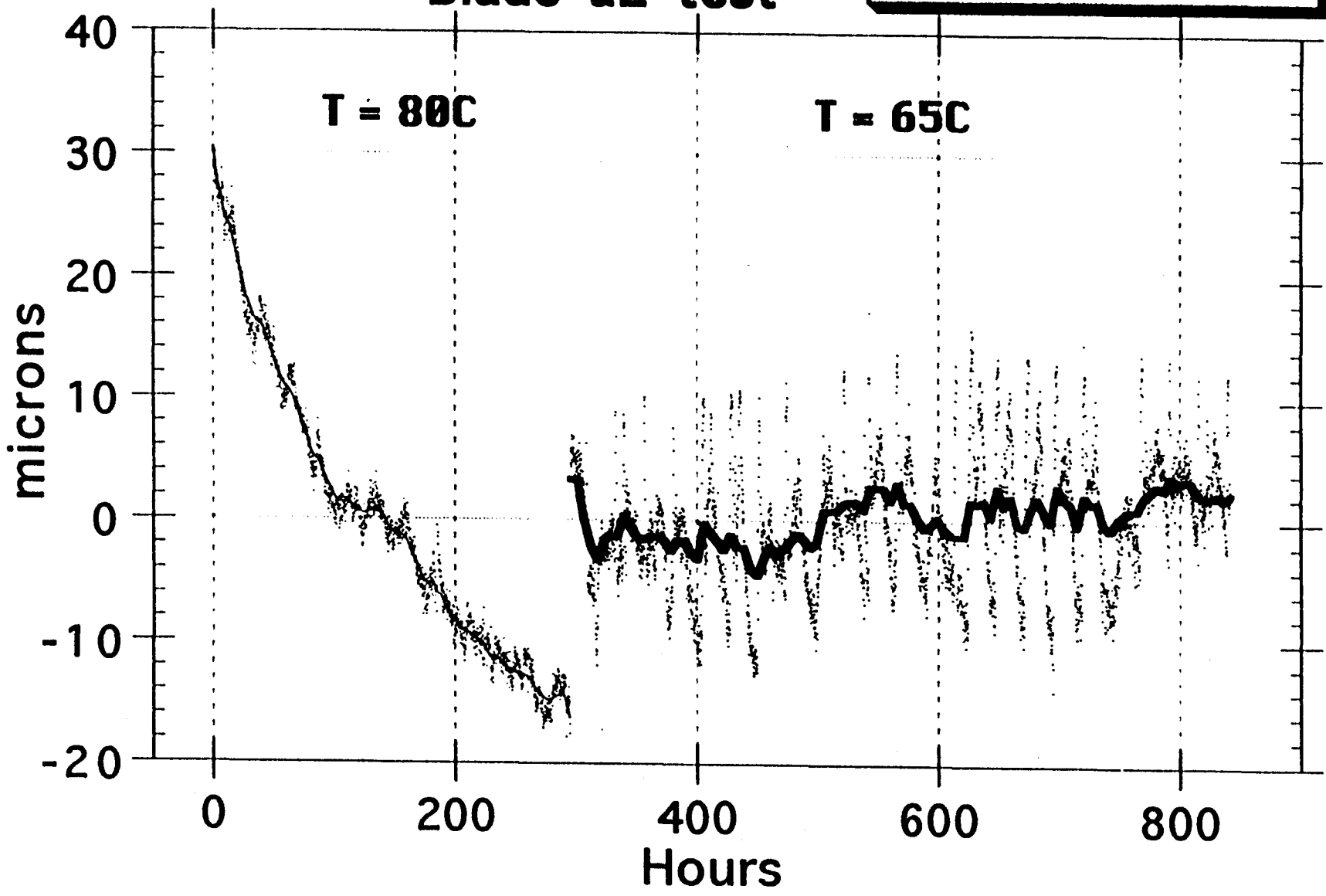
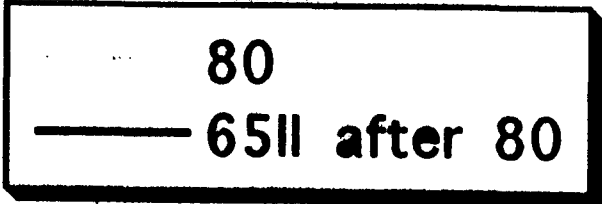

α CREEP (LOGARITHMIC)

Maraging activation energy determination

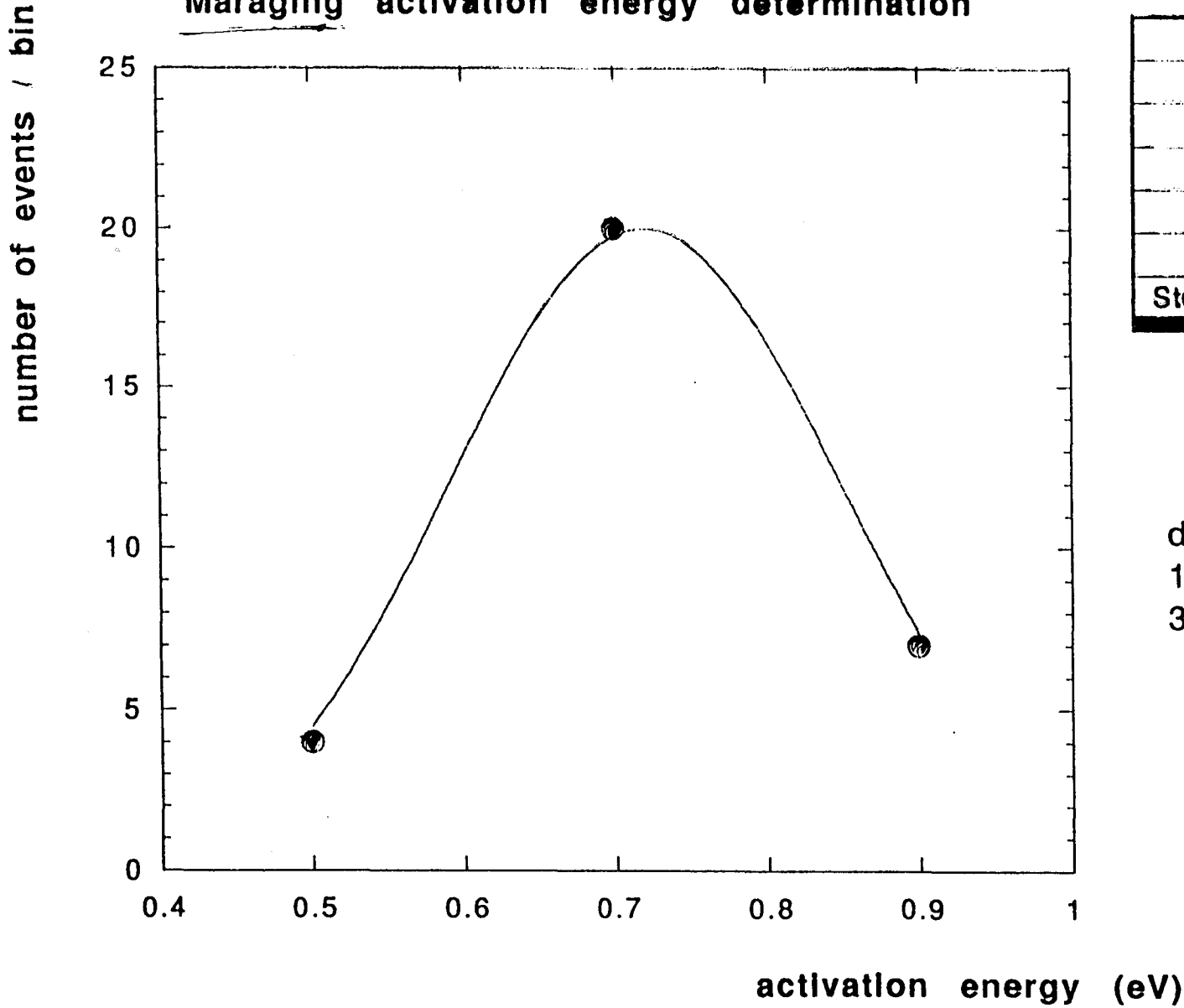

	X
Minimum	0.51405948
Maximum	0.95582467
Sum	22.237414
Points	31
Mean	0.71733593 [eV]
Std Deviation	0.10820836

dE determination on
11 blades and
3 temperature steps

Slope vs Load

- Slope 50
- △ slope 65
- slope 80
- Slope 65 II

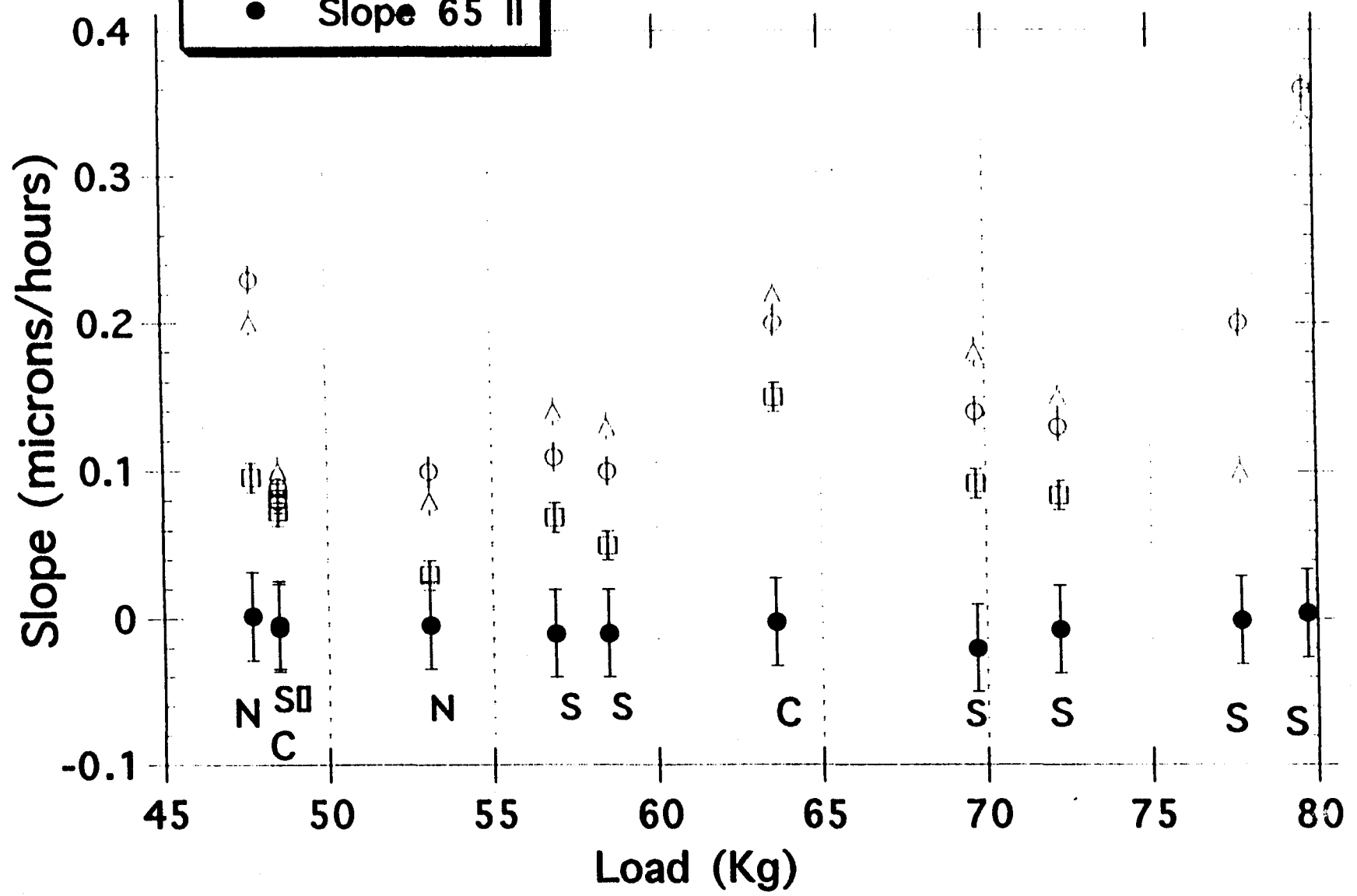

STAY WELL INSIDE OF
LINEAR REGION TO LOW FILTERS

Strain -Stress Curve

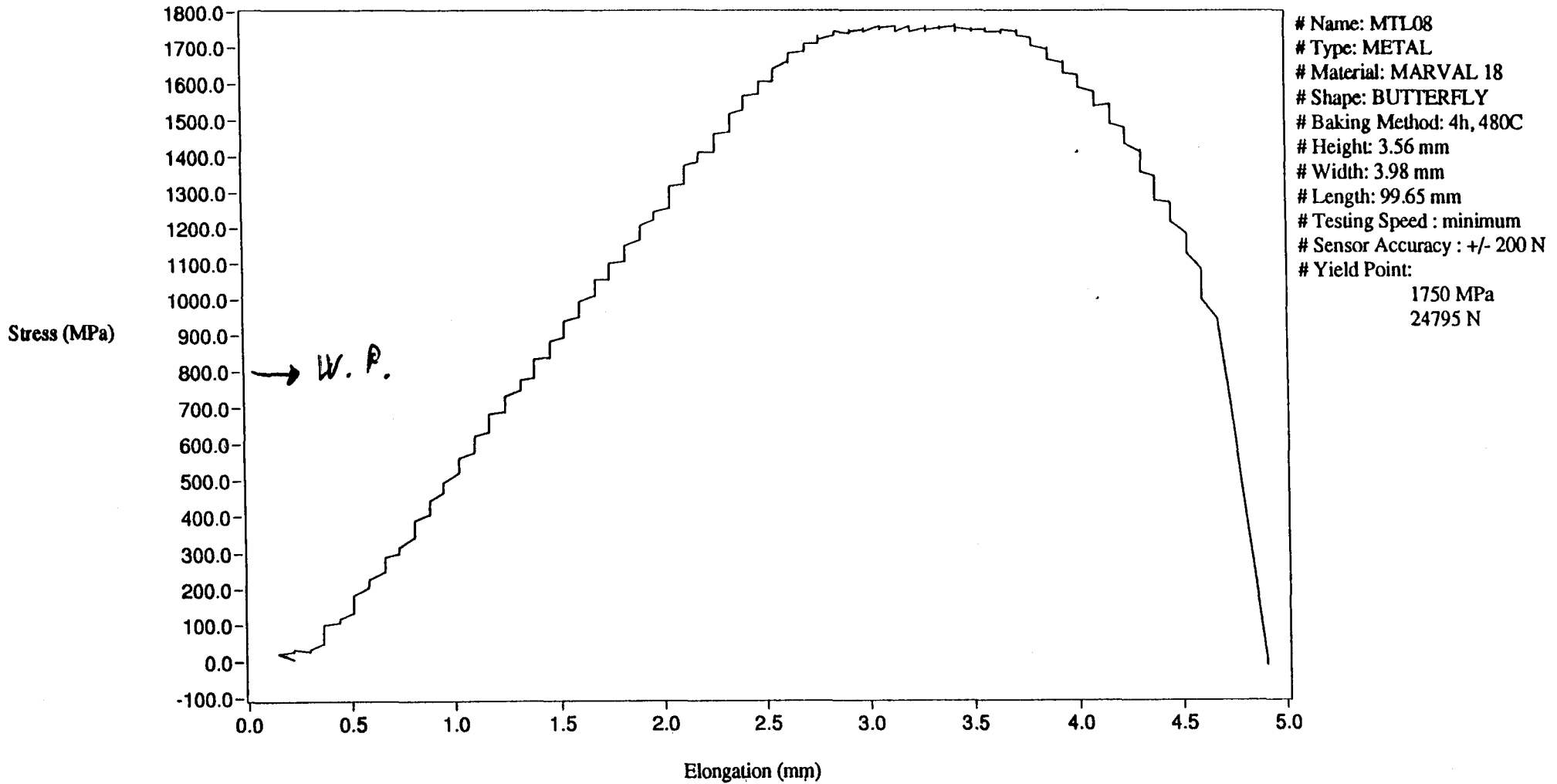

MTL08.HYS

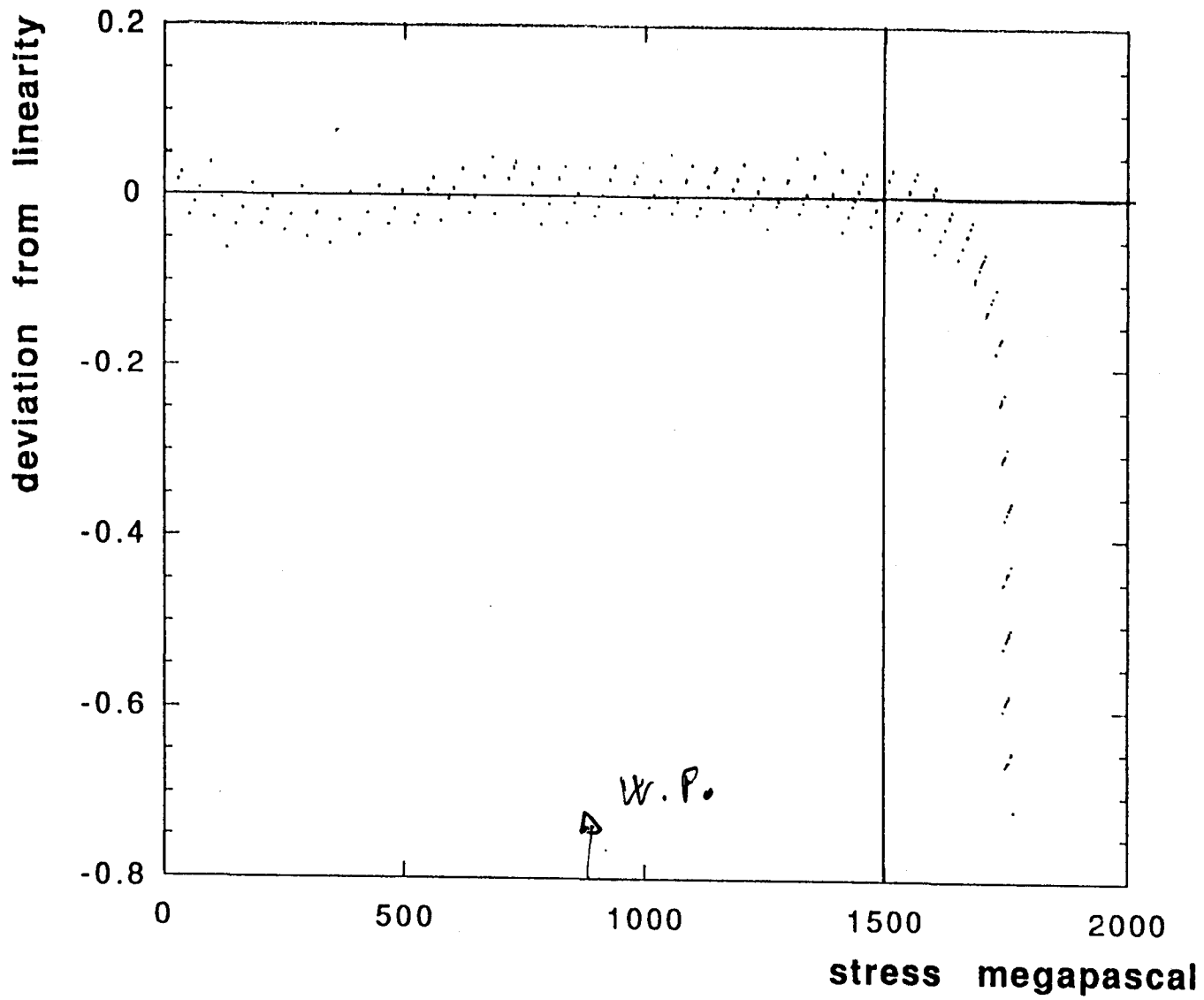

Defences against creep noise

A)

Maraging steel used in all stressed components

B)

>150°C baking of assembled attenuators

relieves excess stresses and

consumes all possible slippage

C)

If will detect problems with Virgo operation

further safety factor by chilling

No low temperature brittleness with Maraging

DEFENCE AGAINST

CREEP LIKE NOISE

FIGHT AGAINST HISTERESIS

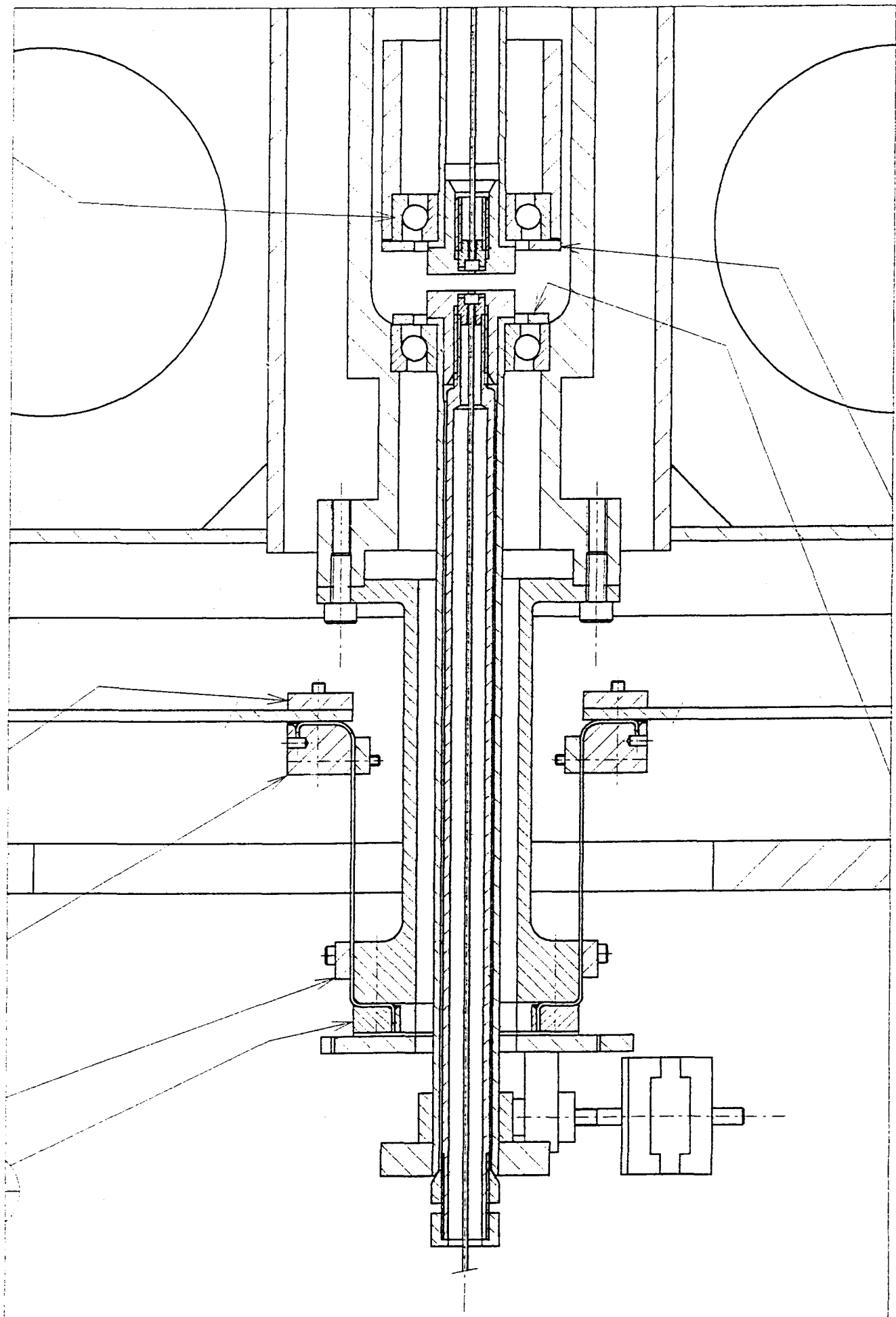

Thermal movement noise and upconversions

if quantised fraction is 10^{-6}

if thermostatisation $< 10 \text{ m}^\circ\text{K}$

and if creep like (10^{-12} m) steps

then thermal movement noise will generate

1 step / hour

but if quantised fraction is 10^{-5}

if thermostatisation $< 100 \text{ m}^\circ\text{K}$

then thermal movement noise will generate

100 steps / hour

Thermal movement noise and upconversions

Filter motions of $300 \mu\text{m}/^\circ\text{C}$

with a thermal stability of $10 \text{ m}^\circ\text{K}$ \Rightarrow

$3 \mu\text{m}$ motions with a time scale of 3 Hours

$\Rightarrow 1 \mu\text{m}/\text{hour}$

of this $1 \mu\text{m}/\text{hour}$ motion

what fraction is smooth?

what fraction is quantised?

10^{-3} ? 10^{-6} ? 10^{-9} ?

\uparrow

$> f_{20M} R$

can expect :

$\begin{matrix} \nearrow \\ \searrow \end{matrix}$ creep like steps

$\begin{matrix} \nearrow \\ \searrow \end{matrix}$ larger steps (screeching noise)

MAGNITUDE OF
THE PROBLEM

Precipitation hardened steel

Additional comparisons between

standard spring steel and

precipitation hardened steel

Comparisons of hysteresis cycles on wires.

R. DeSalvo Amaldi conference 1/4 July 1997

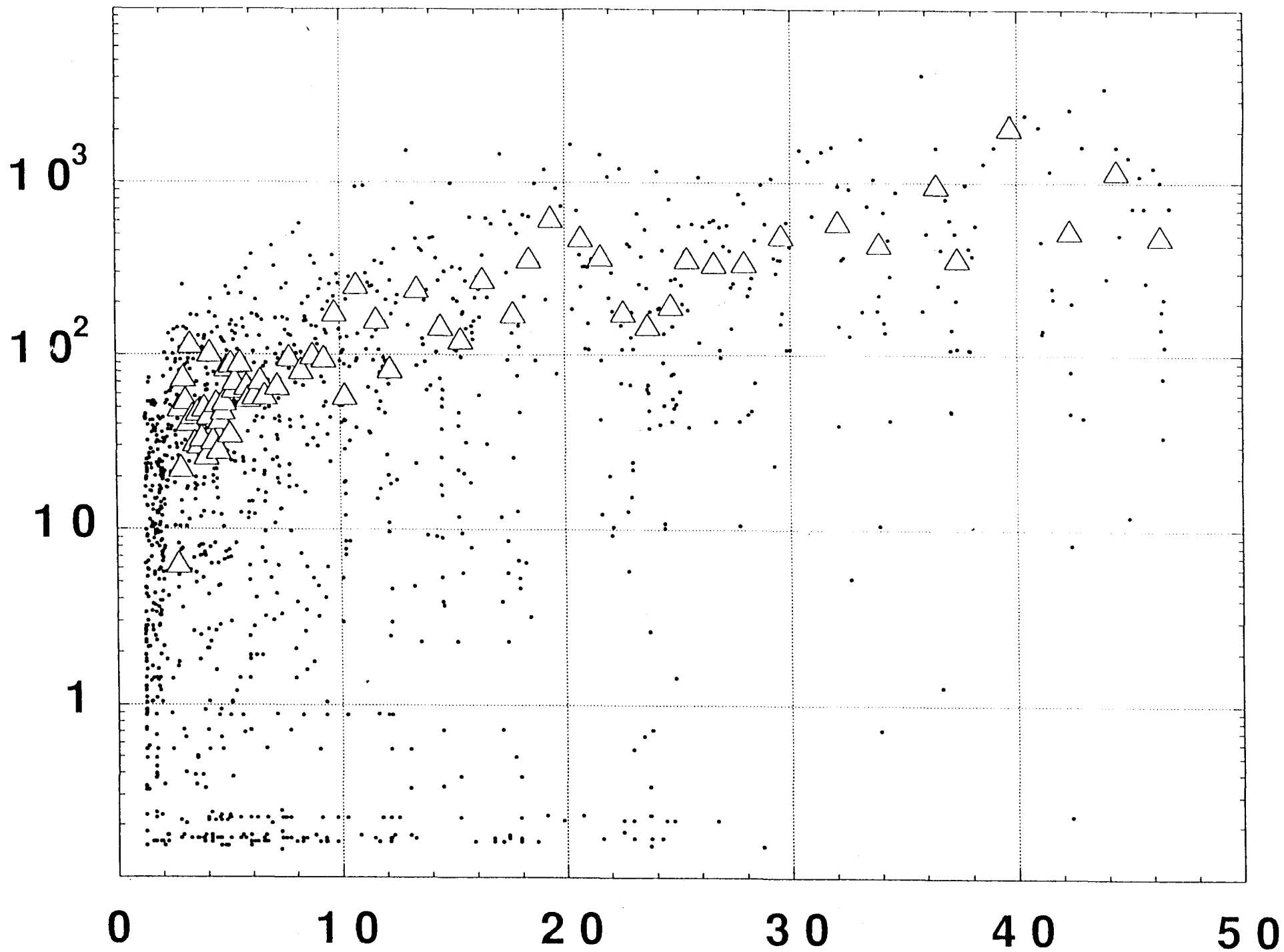

observed after this initial cycle.

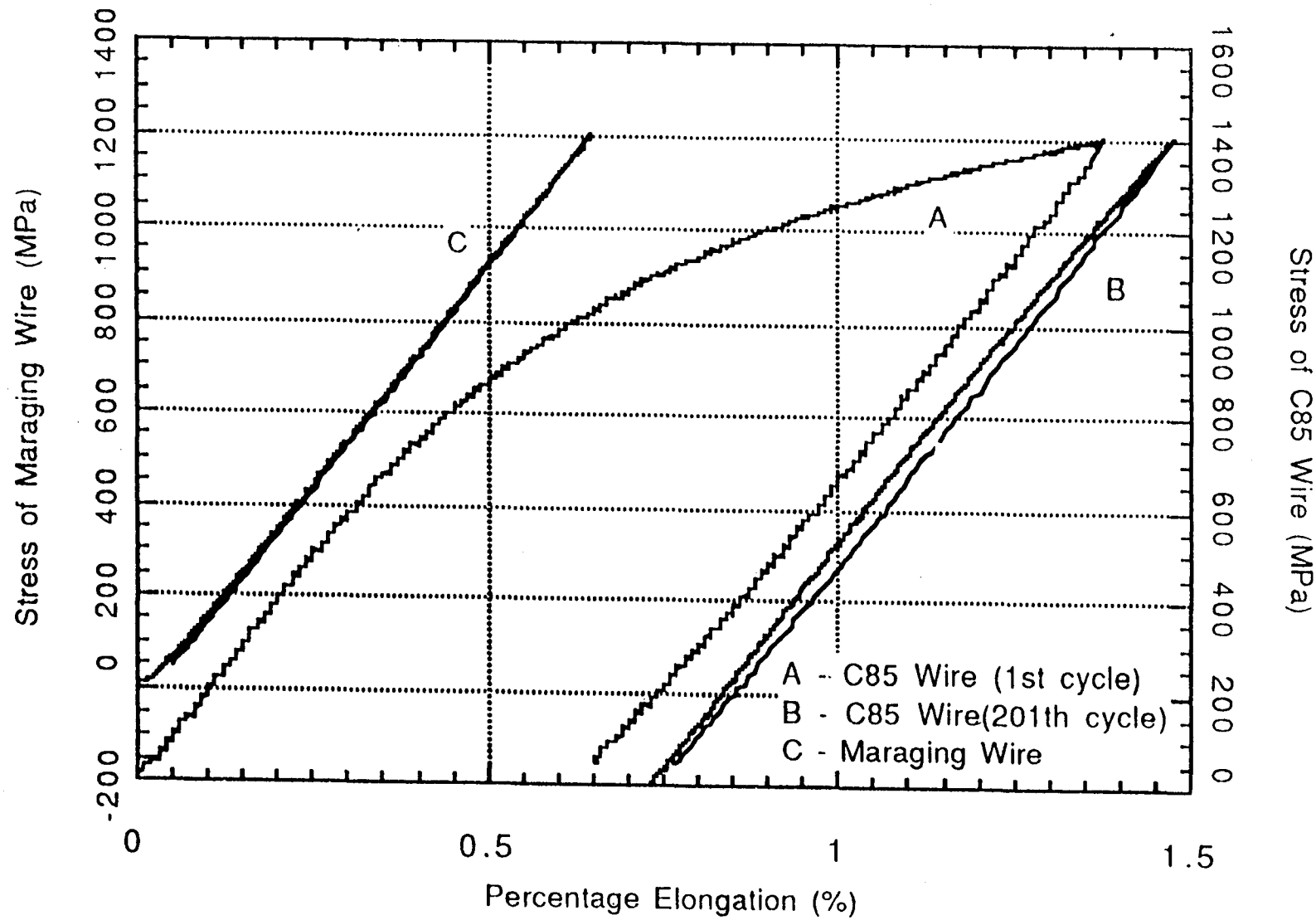
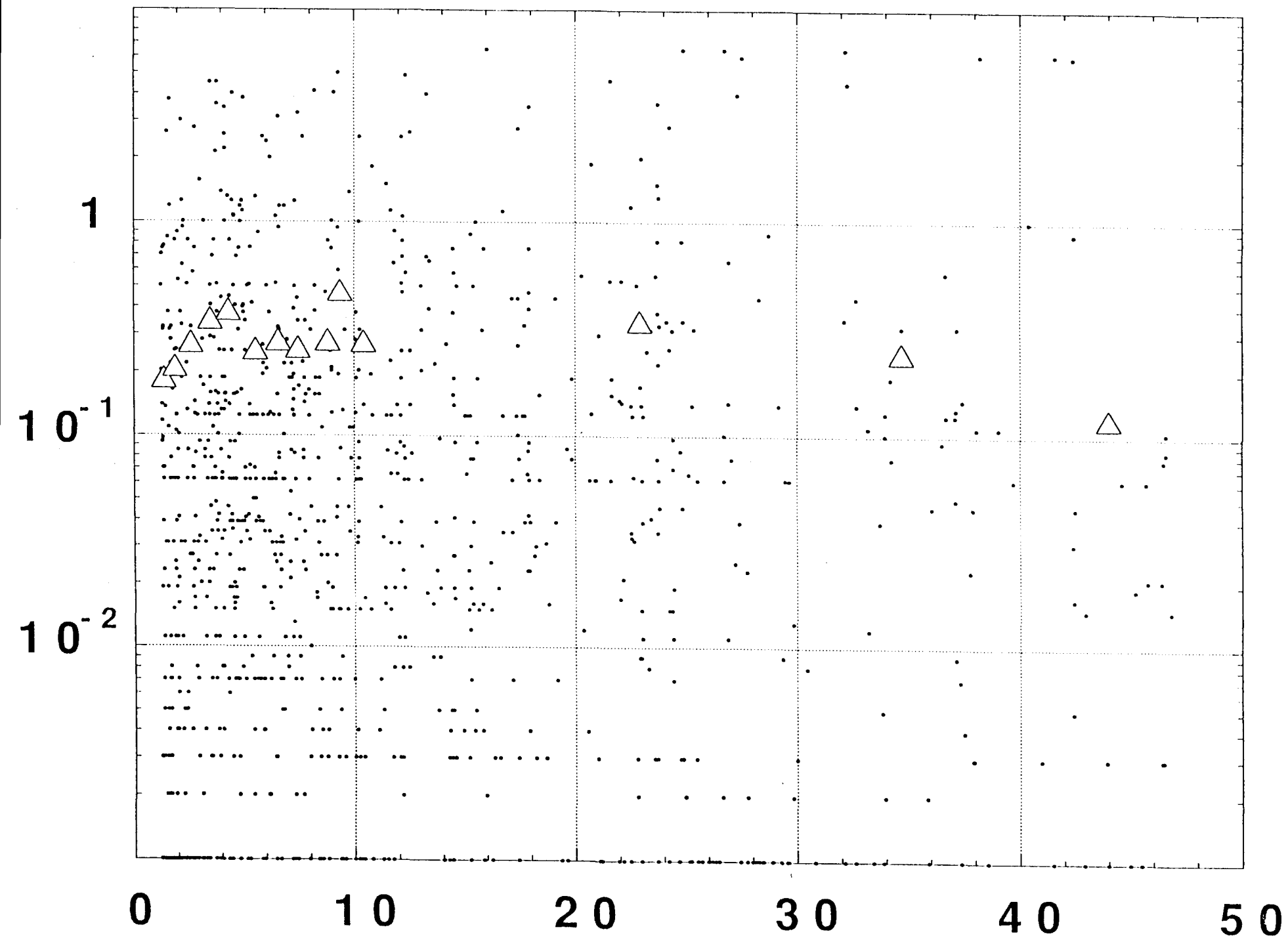

Fig.2 Behavior of Strain and Stress of the Piano and Maraging Wires



SUSPENSION WIRE
HYSTERESIS MEASUREMENT

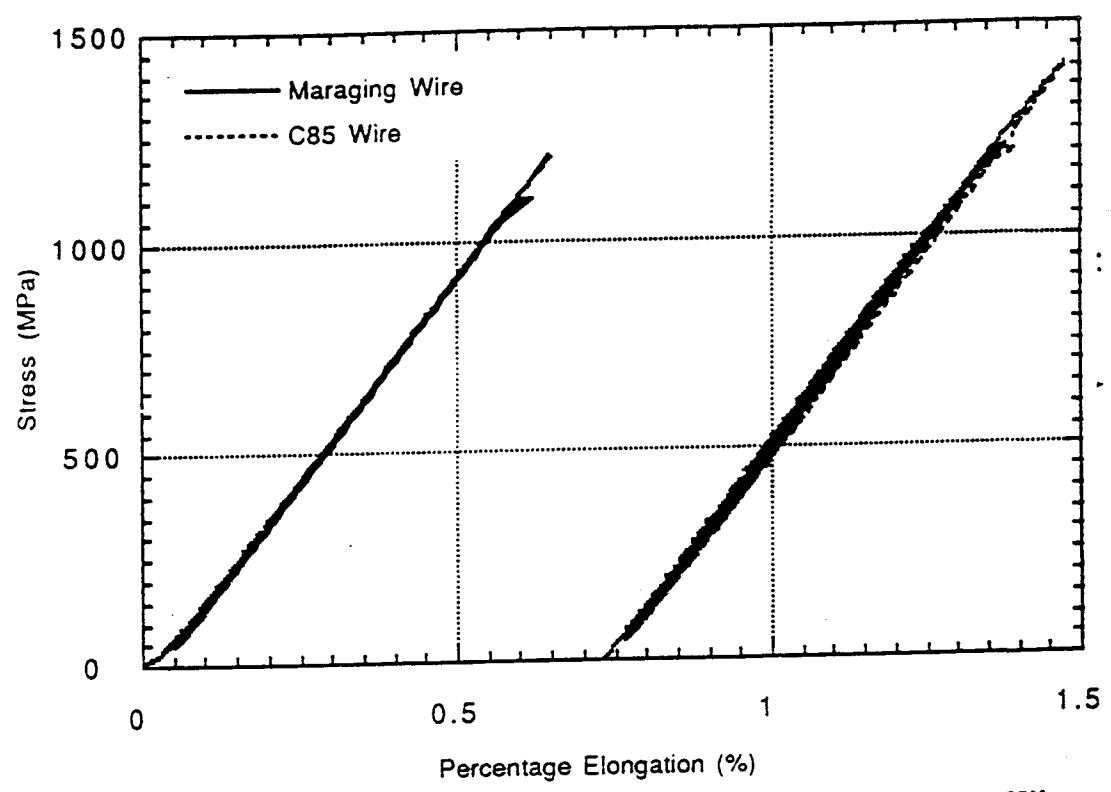
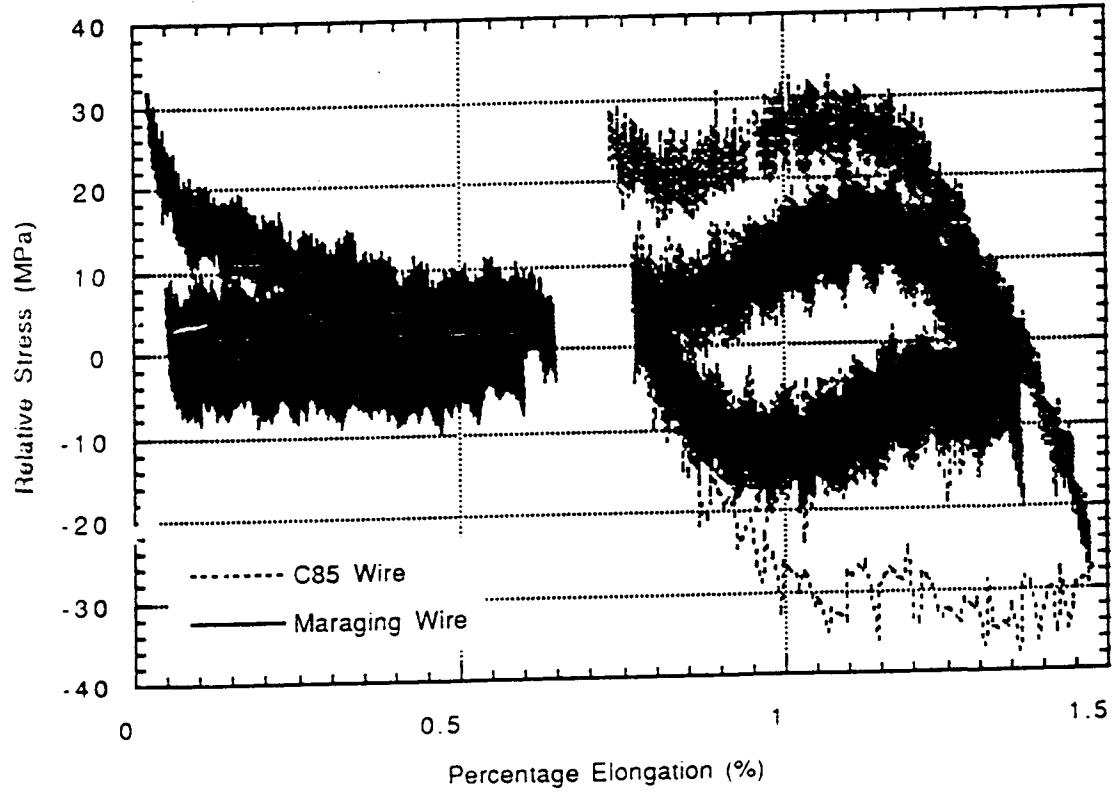

Fig.3 Hysteresis Cycles of the Piano and Maraging Wires



STRESS
MPA 100

x 2

A)

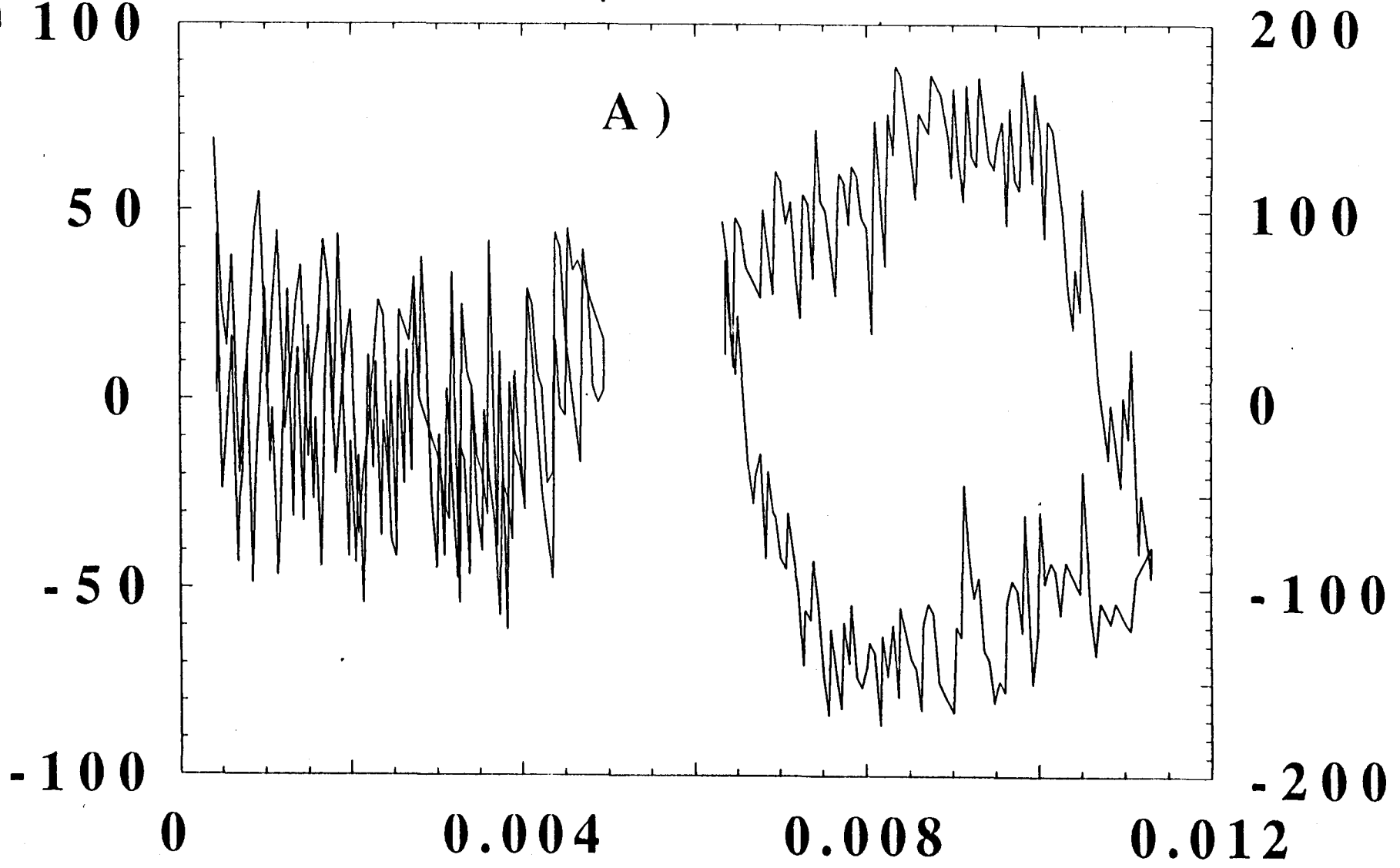

STRAIN

MPa
12000

$\times 10$

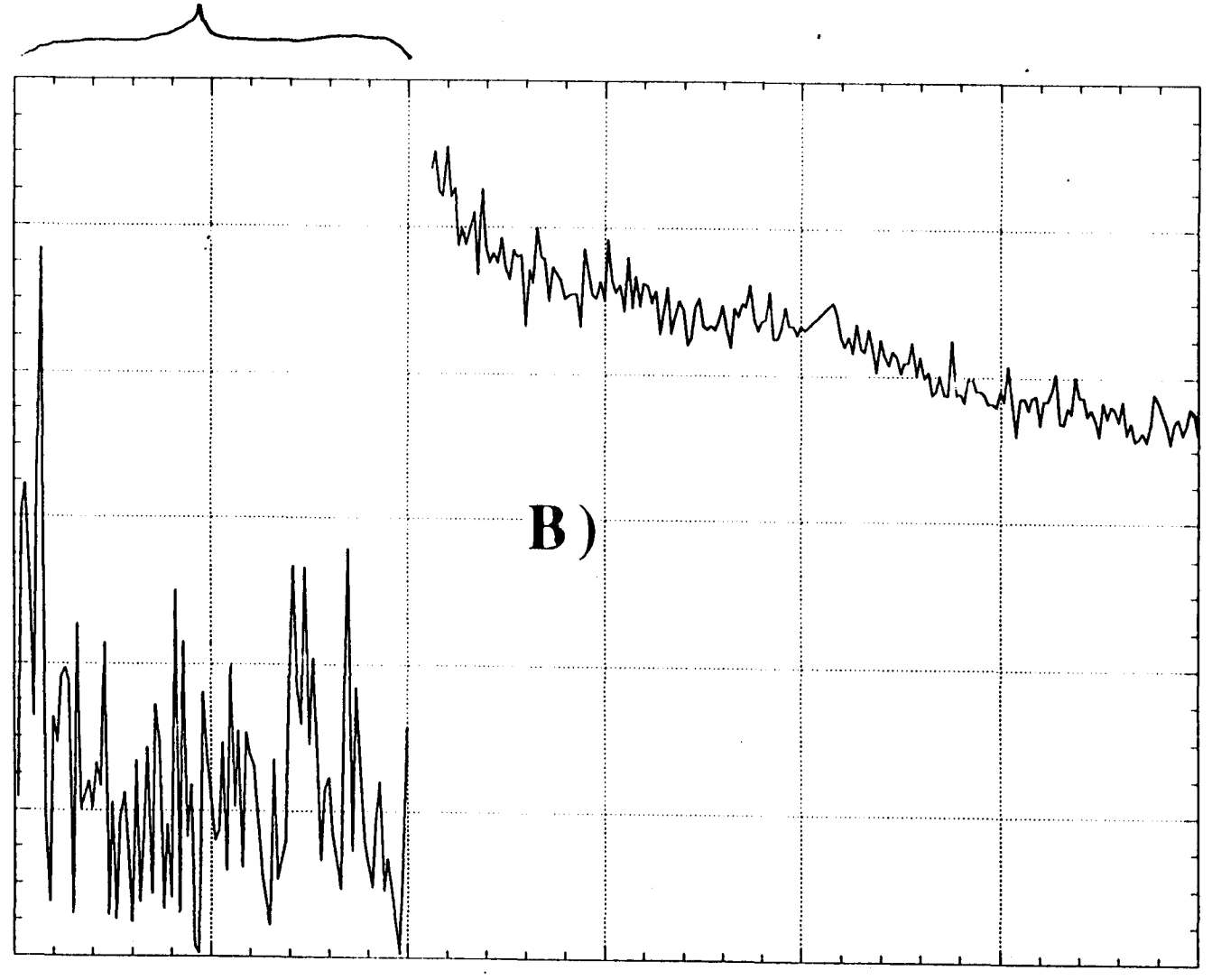

8000

4000

0

0

100

200

300

cy
#

120000

80000

40000

0

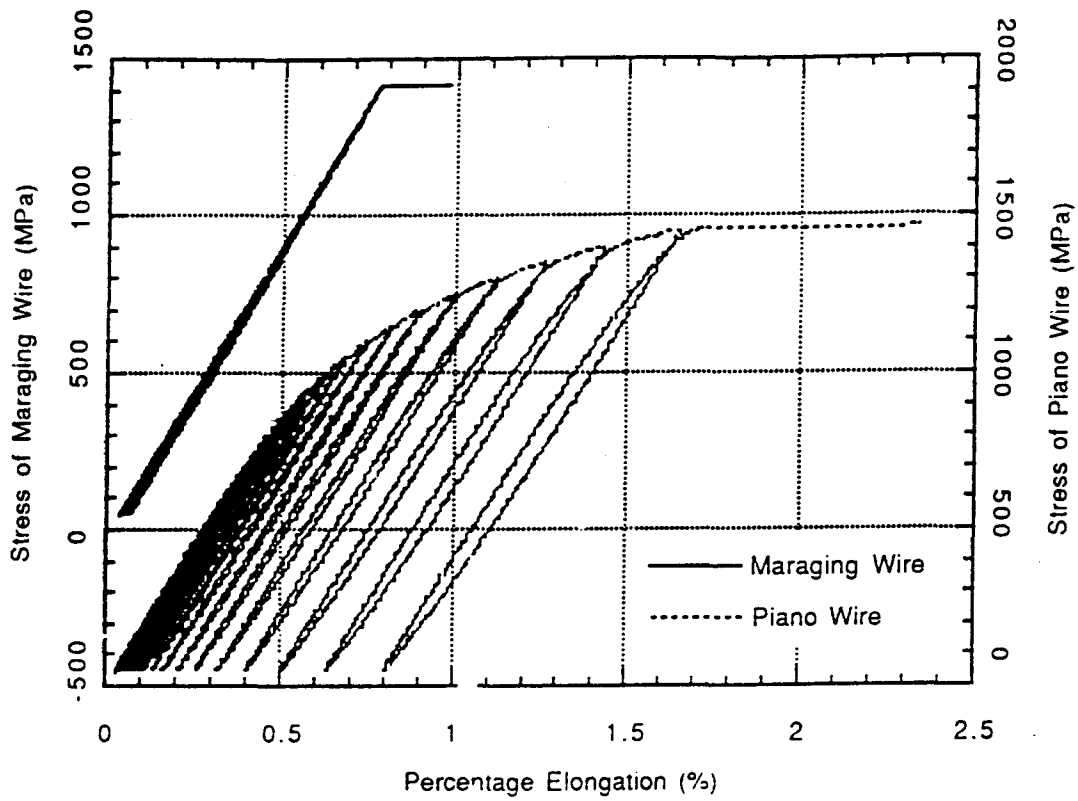

Fig.7 Hysteresis Cycles of the Broken Wires

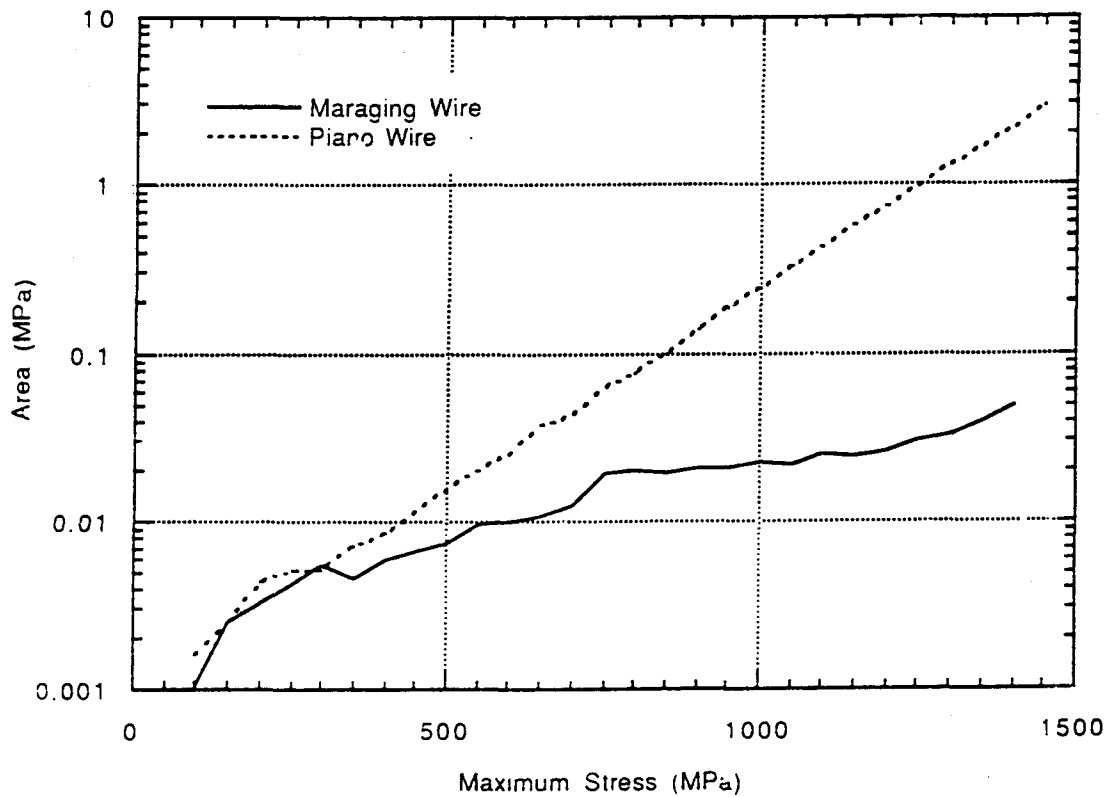
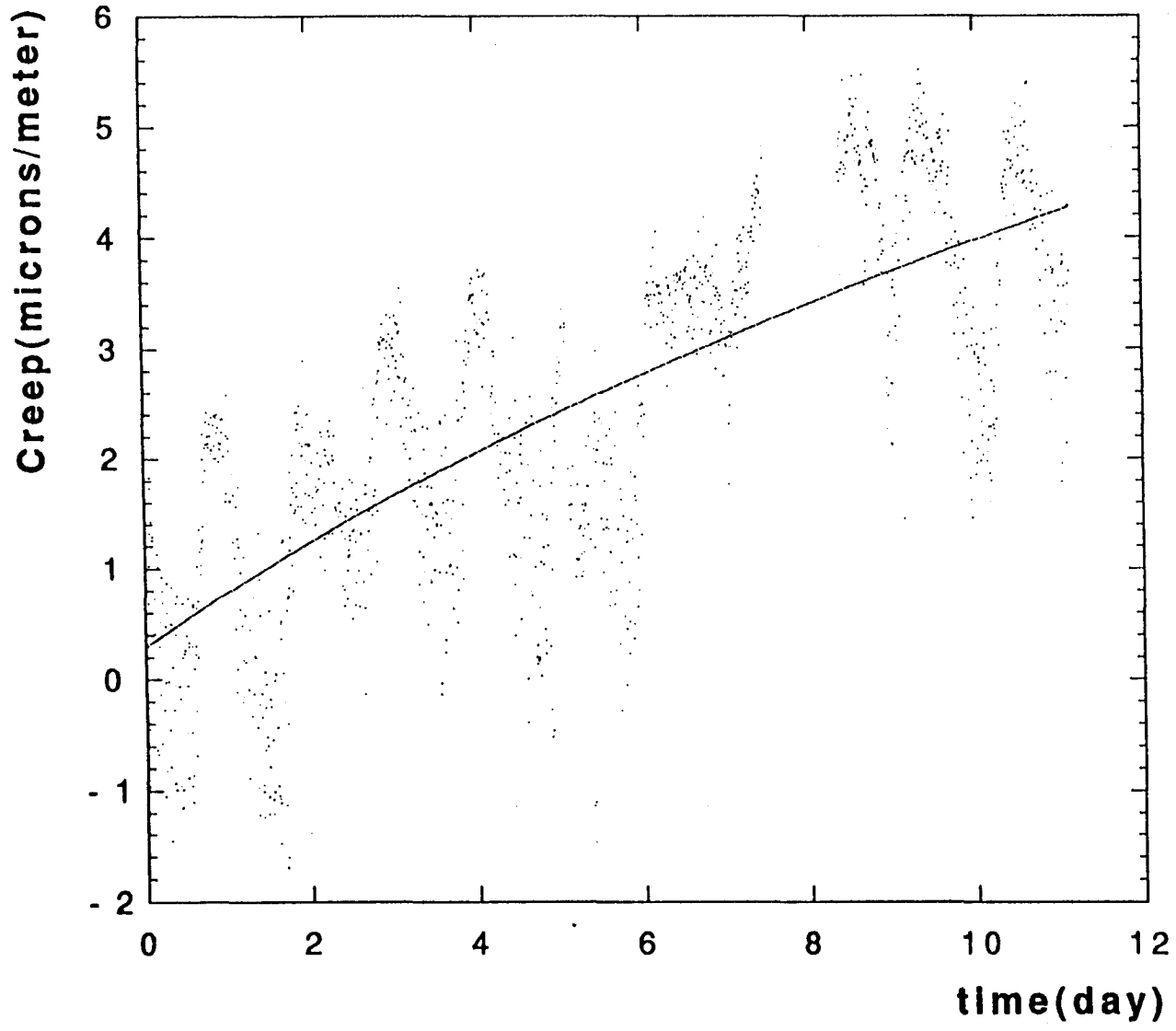

Fig.8 Hysteresis Area of the Broken Wires

Temperature 30°C



WLR

y = a+b*log(m0+c)		
	Value	Error
a	-13.543	5.4837
b	13.214	3.3455
c	11.128	3.9894
Chisq	1564.9	NA
R	0.74596	NA

Temperature 45°C

DIRE

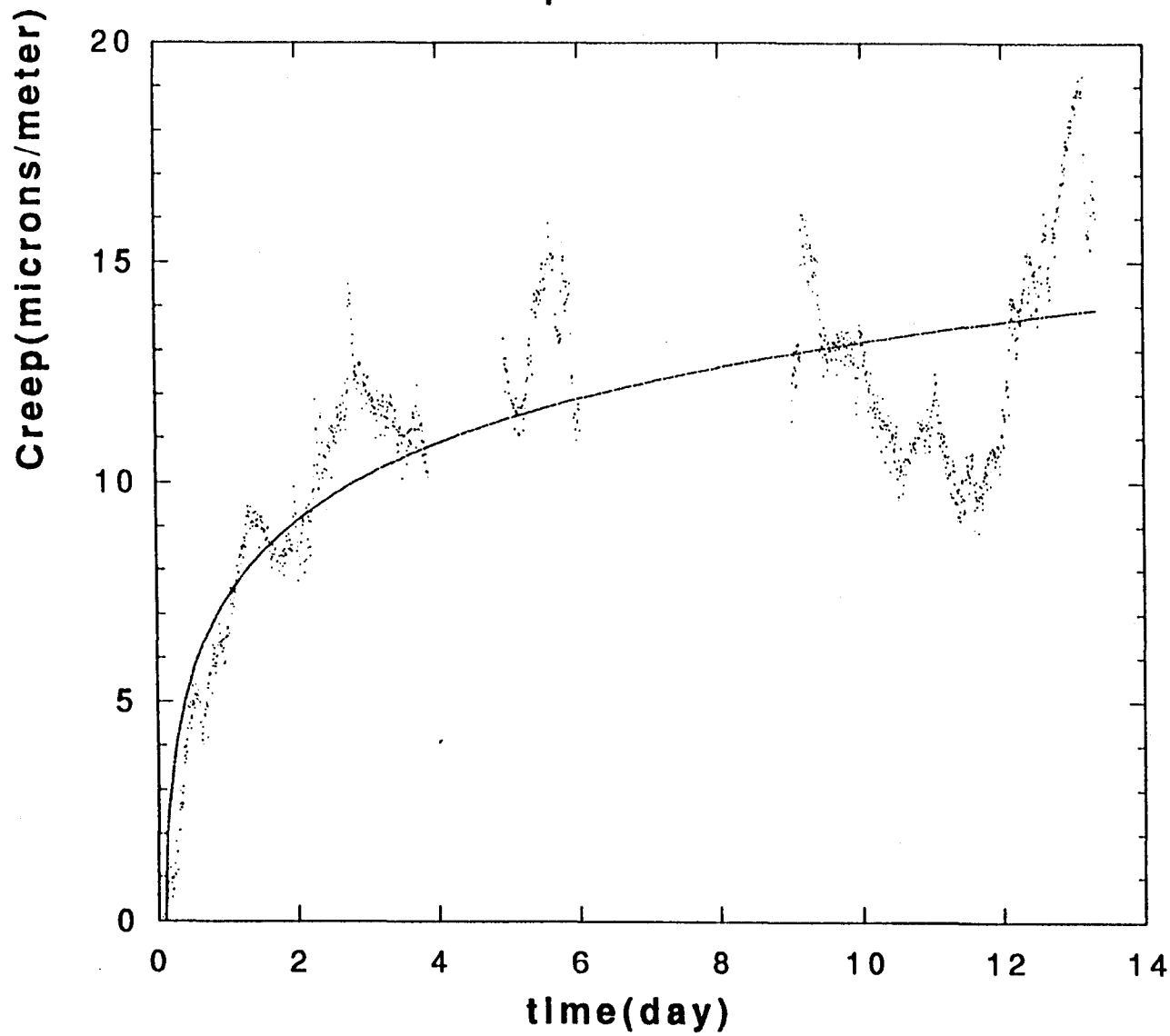

y = a+b*log(m0+c)		
	Value	Error
a	7.3535	0.094554
b	5.8276	0.11665
c	0.0037034	0.0028299
Chsq	5337.4	NA
R	0.82741	NA

WLRG

y = a+b*log(m0+c)		
	Value	Error
a	11.346	0.060988
b	7.8179	0.081742
c	-0.98853	0.0041677
Chsq	1754.9	NA
R	0.95085	NA

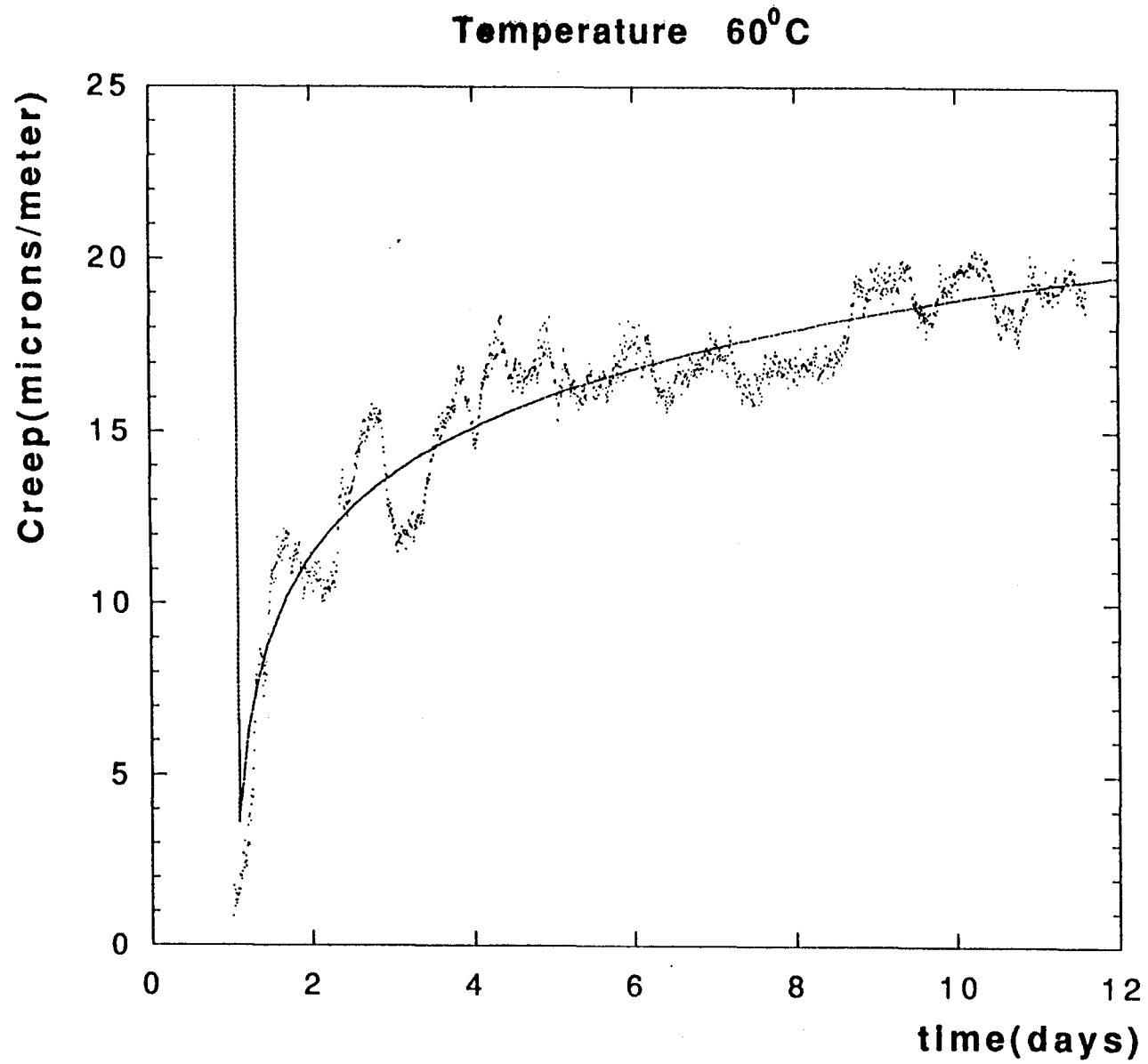

SUSPENSION WIRE TESTS

Temperature 75°C

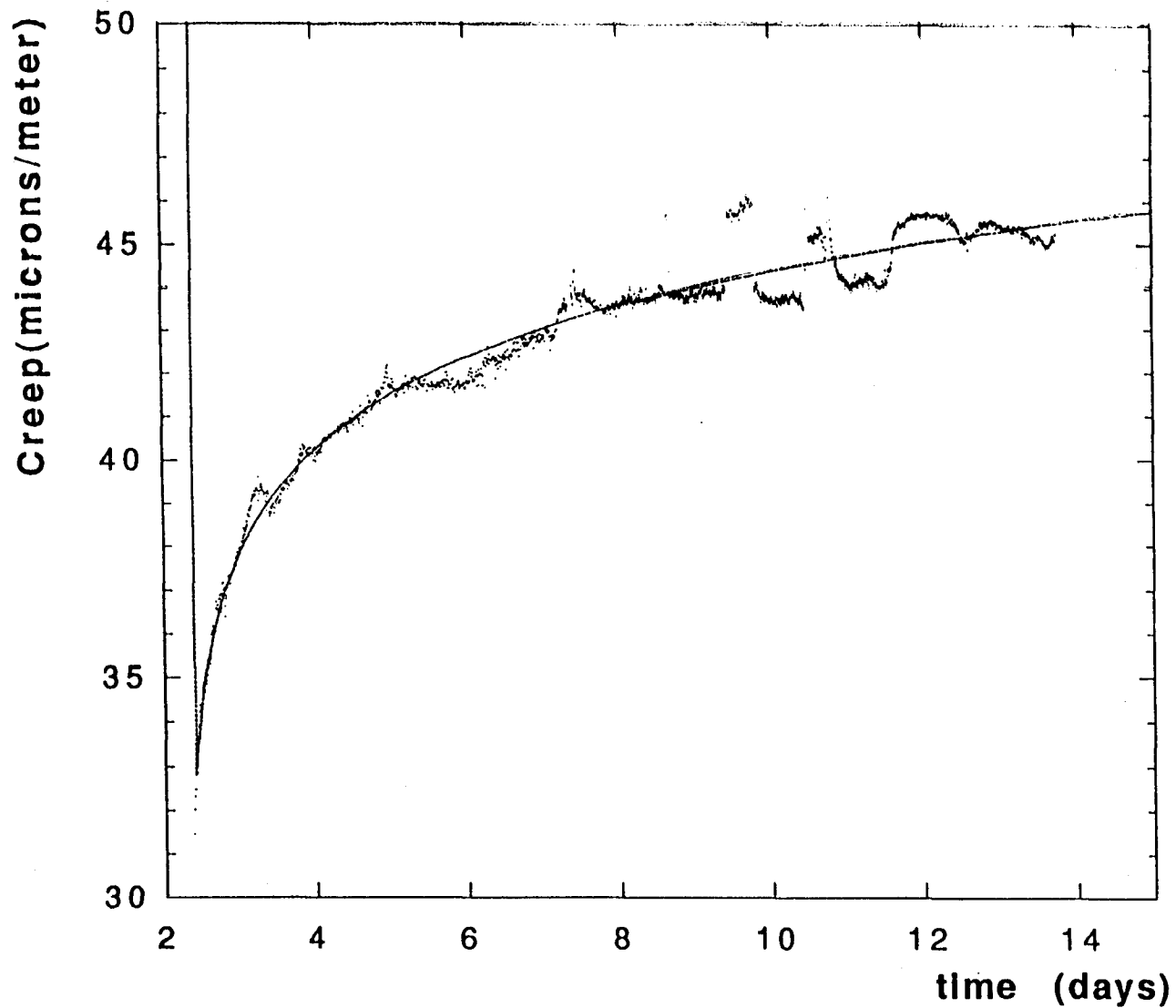

y = a+b*log(mD+c)		
	Value	Error
a	38.891	0.042863
b	6.4114	0.050935
c	-2.2695	0.008277
Chisq	409.32	NA
R	0.98063	NA

SUSPENSION WIRE TESTS

Temperature 70°C

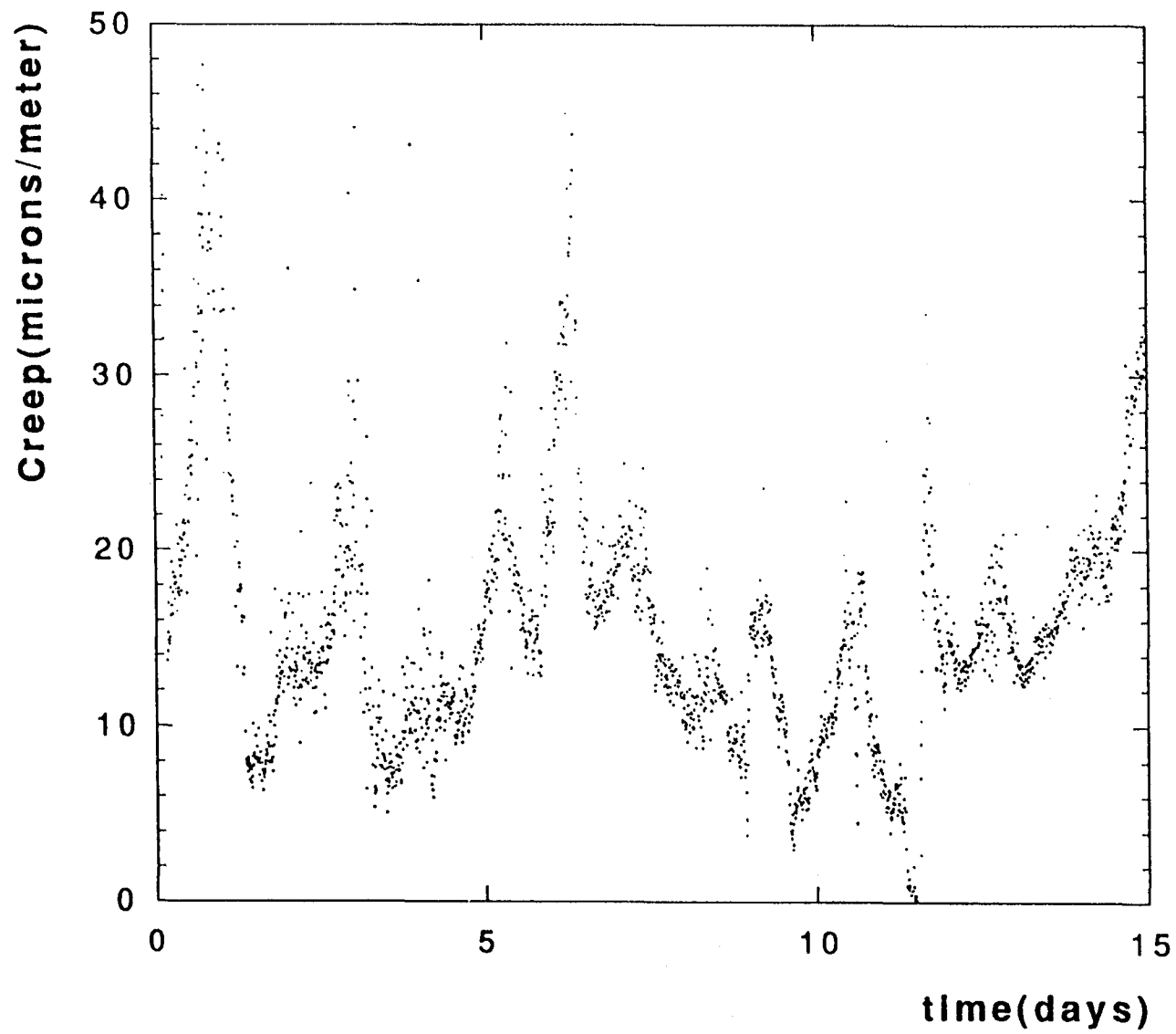

Neutronised State

- Fe
- Co
- Ti

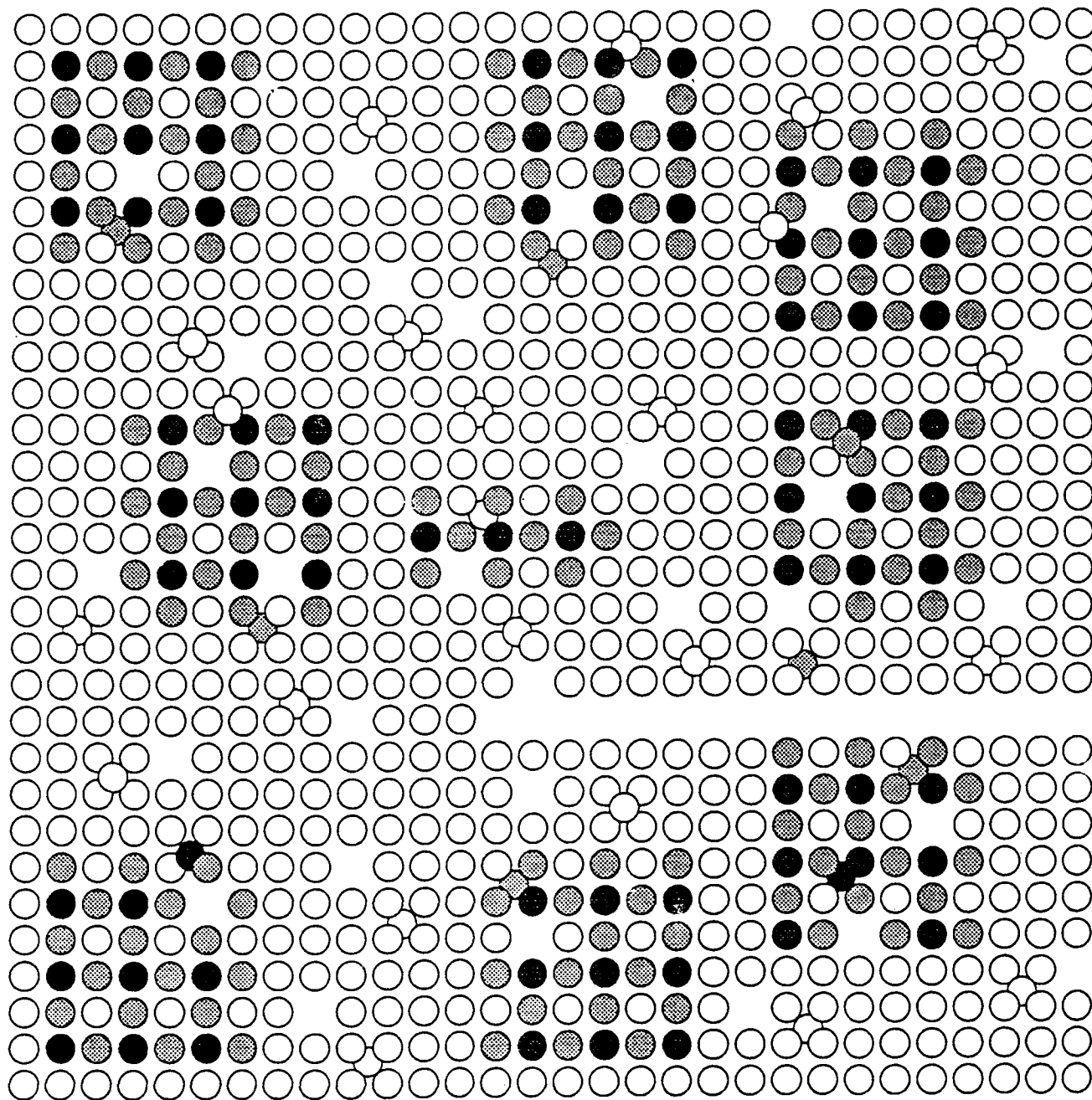

Defences against Thermal movement noise

SCREECHING NOISE

Differential thermal expansion coefficients

kept to a minimum

All points subject to movement

made with flex joints

Best reasonable thermostabilisation

ULTRA LOW HISTERESIS MATERIALS

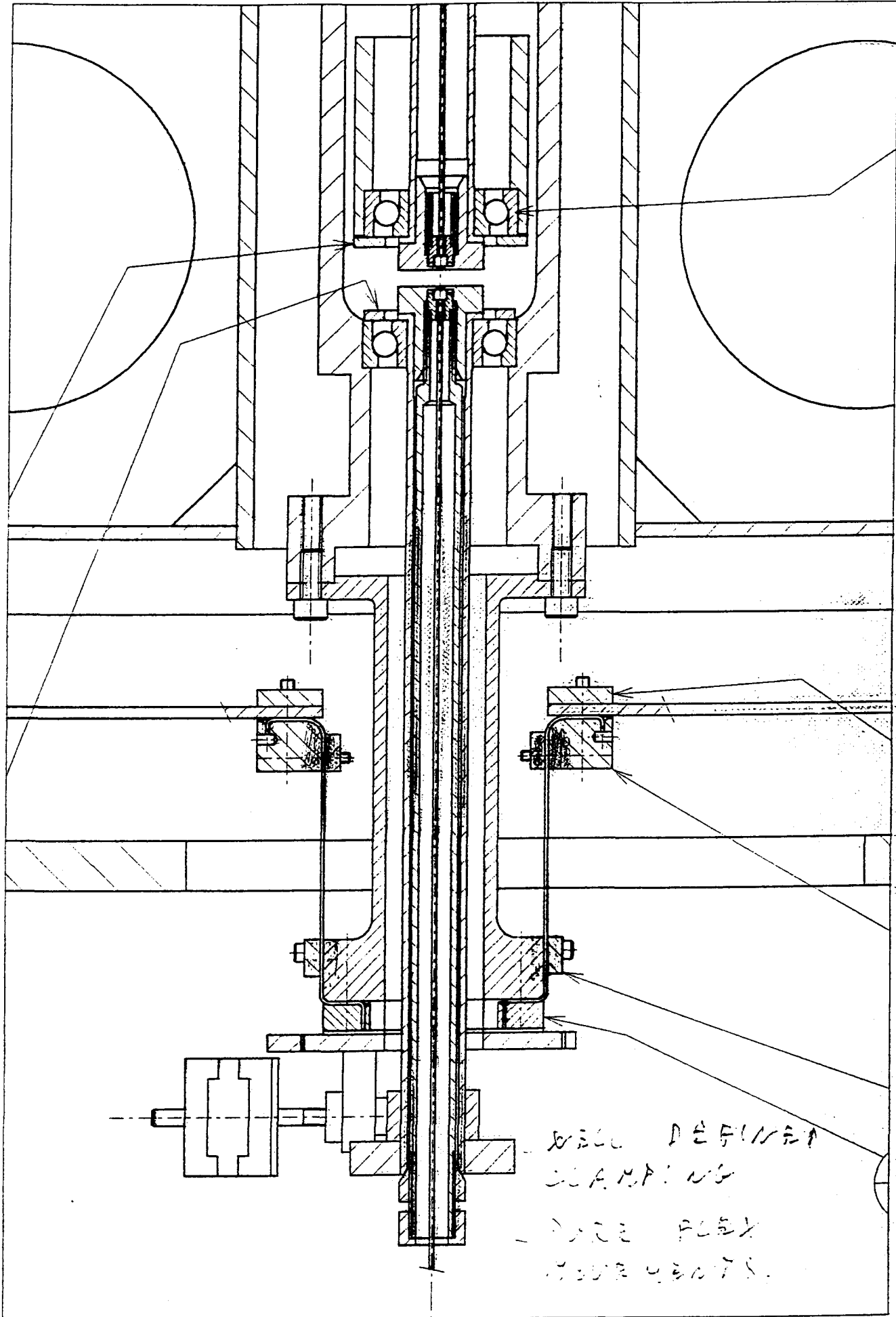

WELL DEFINED
CAMMING
USE PEEK
COMPONENTS.

FIG. 1 B

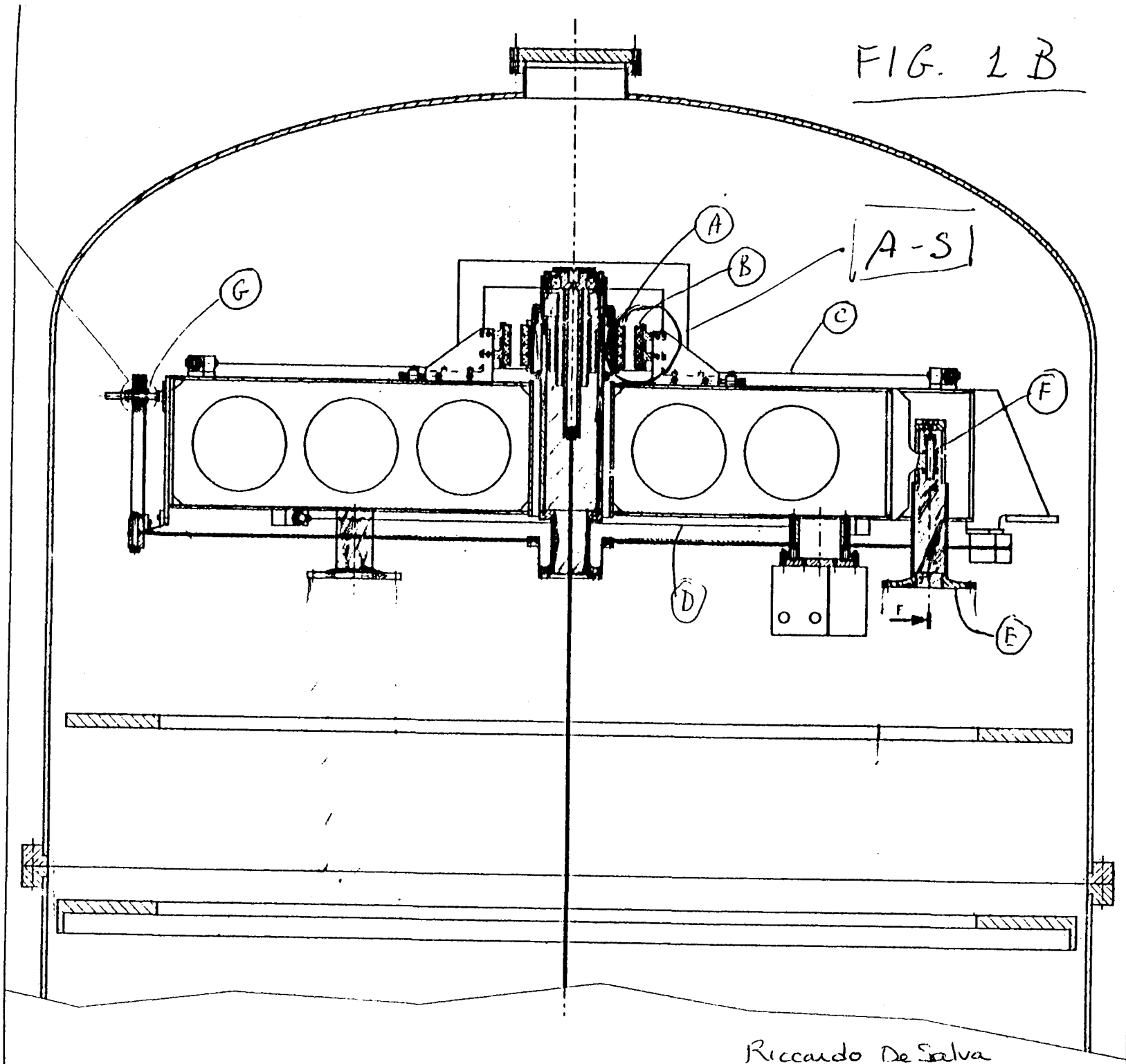

Riccardo De Selva

FIG. 1 A

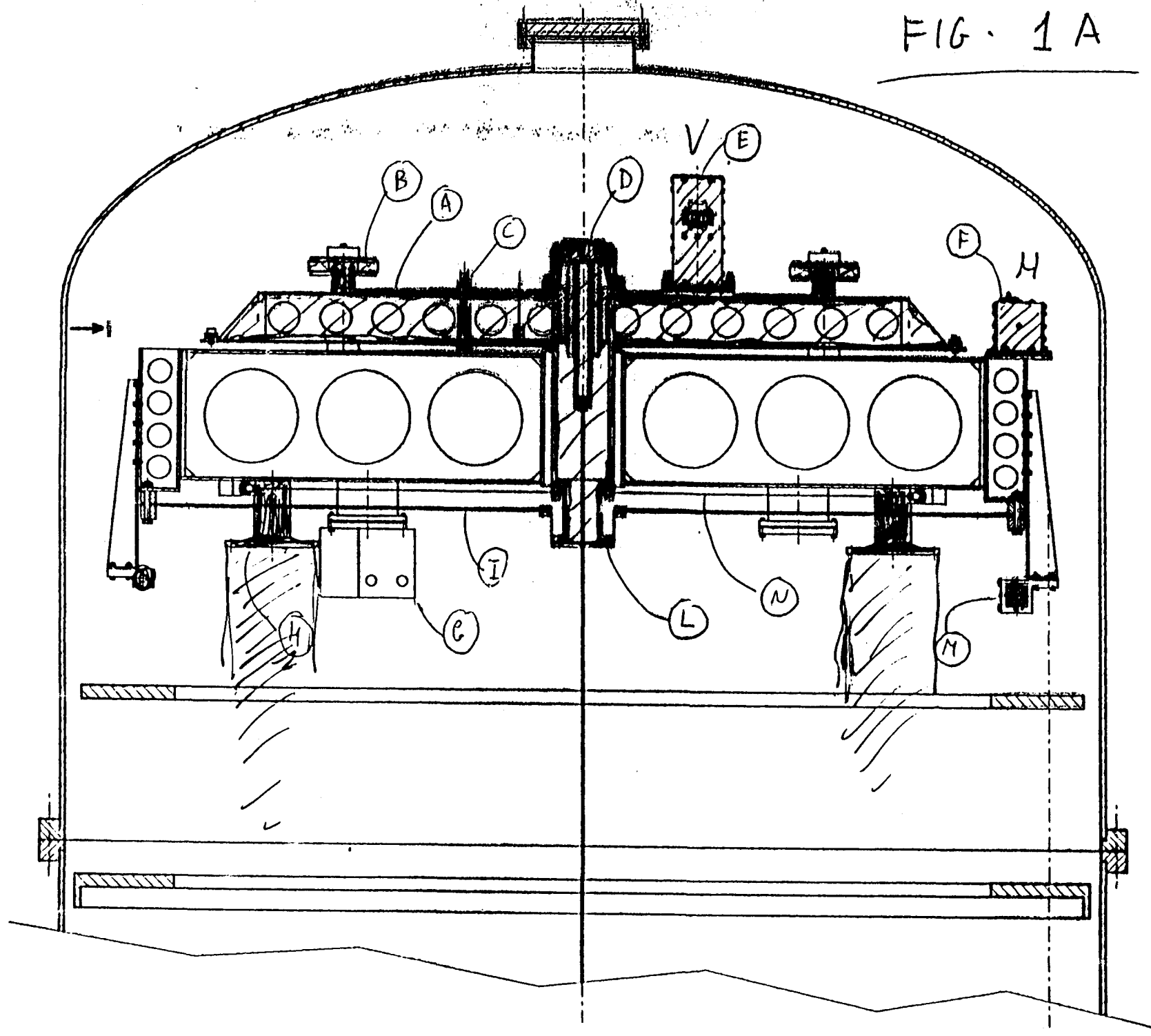

FIG. 1 C

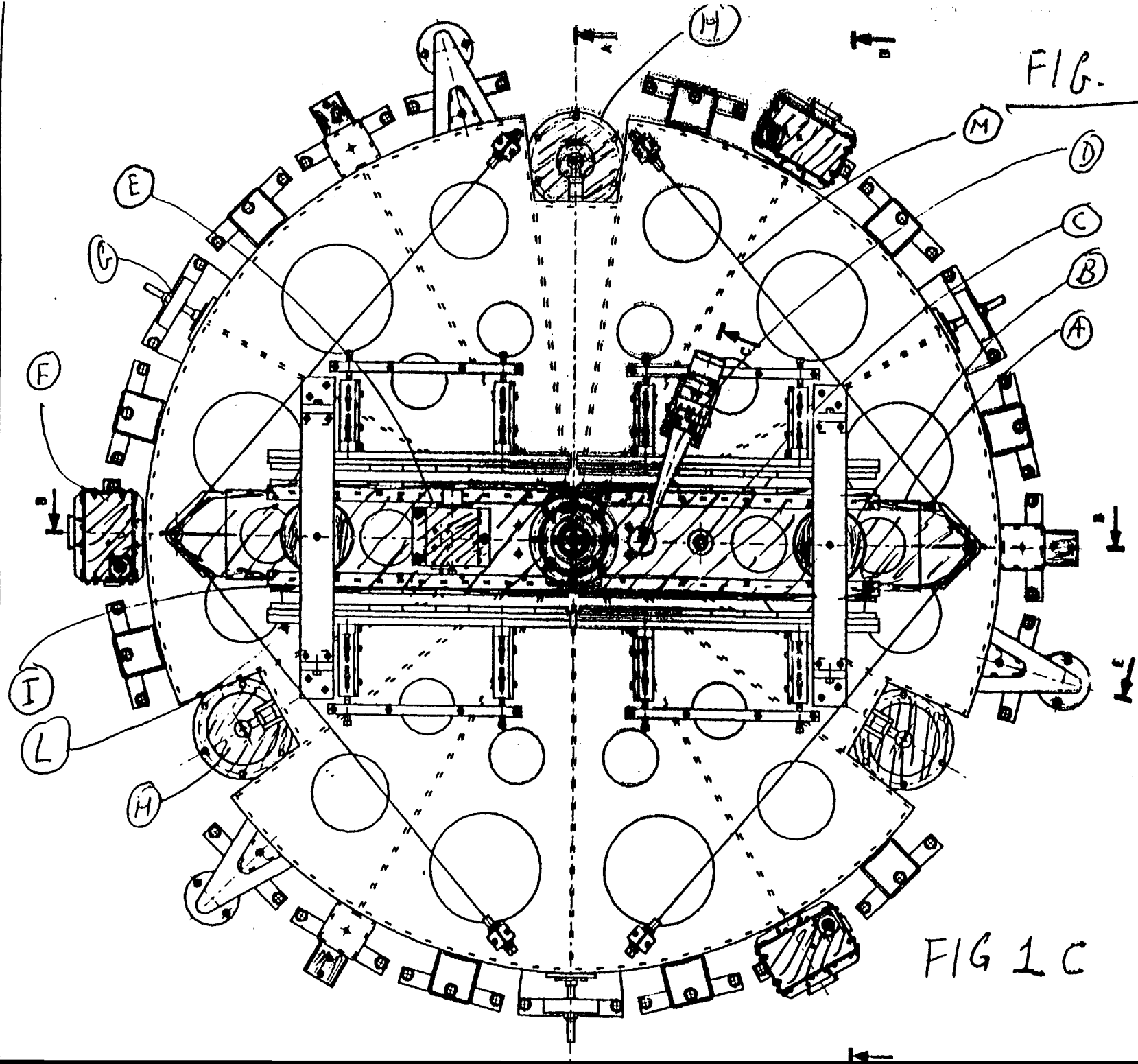

FIG 1 C

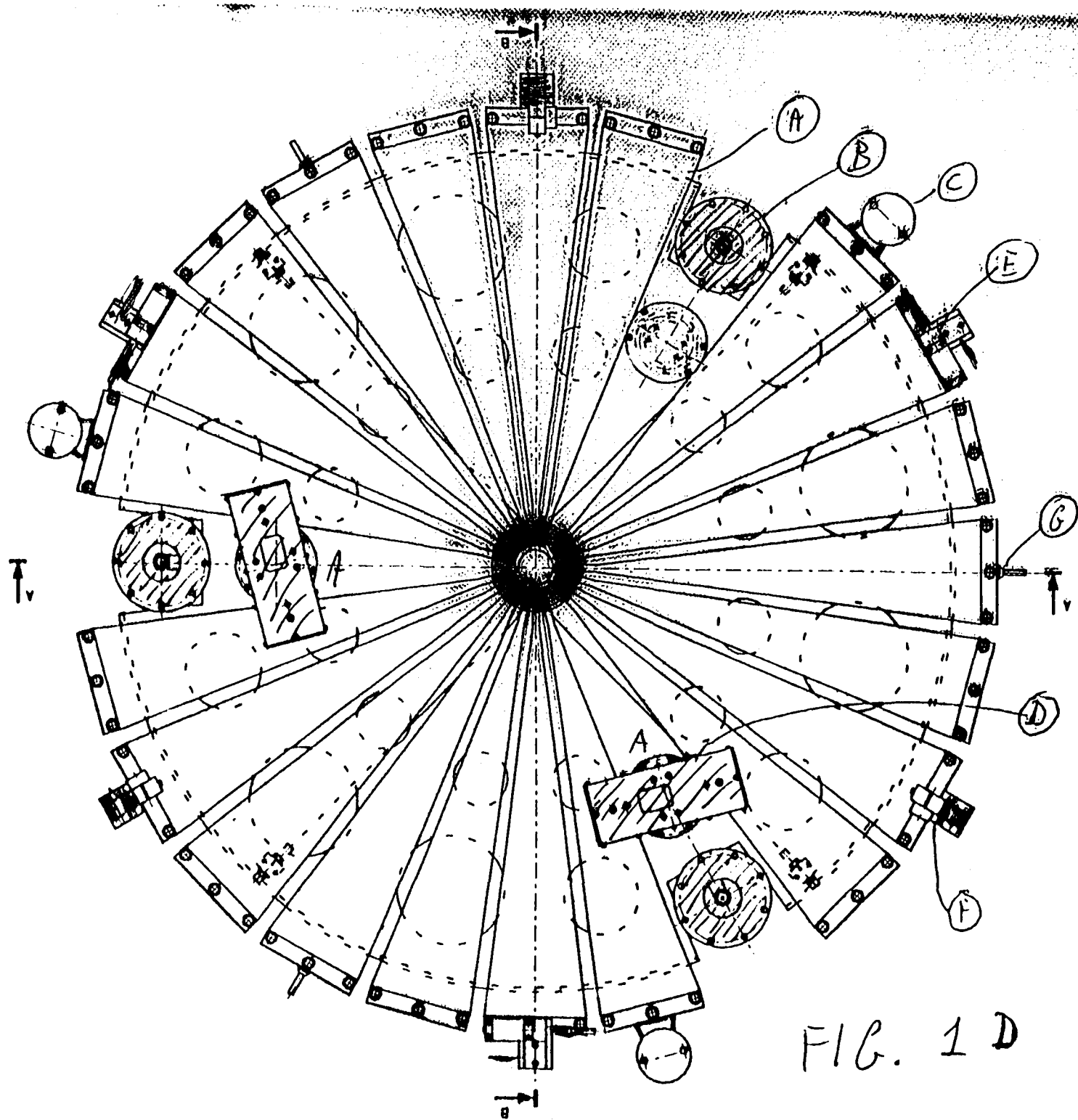
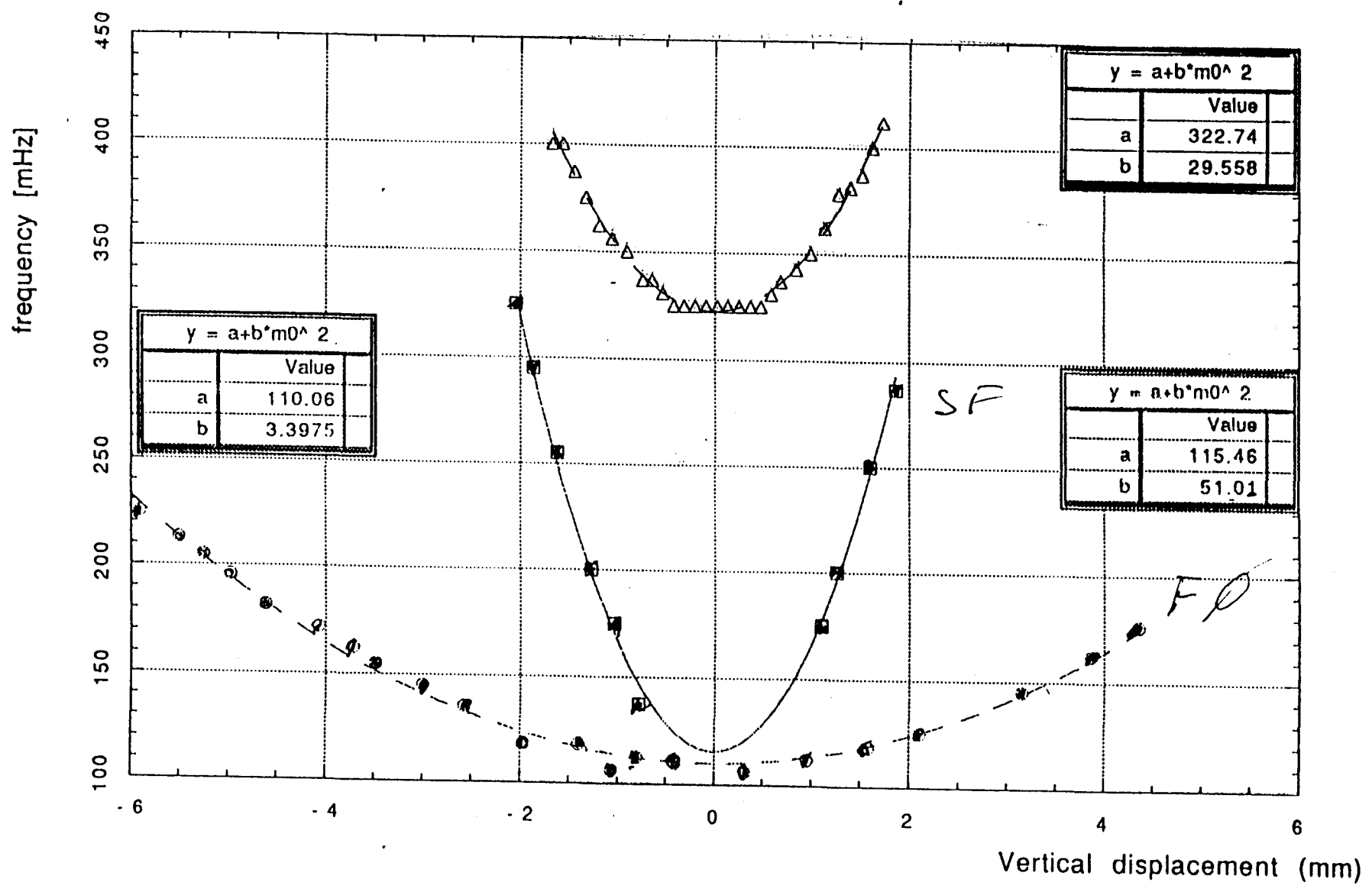

FIG. 1 D

FIG. 2

- Standard filter, tune 320 mHz
- △— Standard filter, tune 115 mHz
- Filter 0, tune 110 mHz



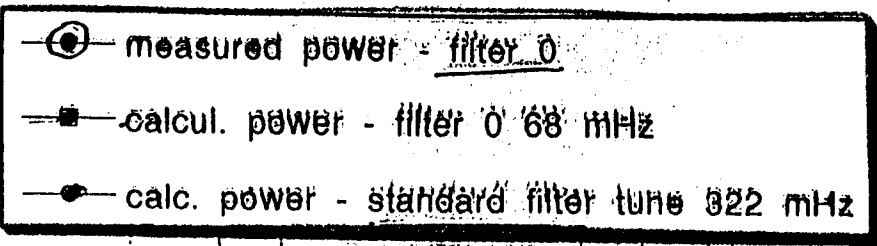
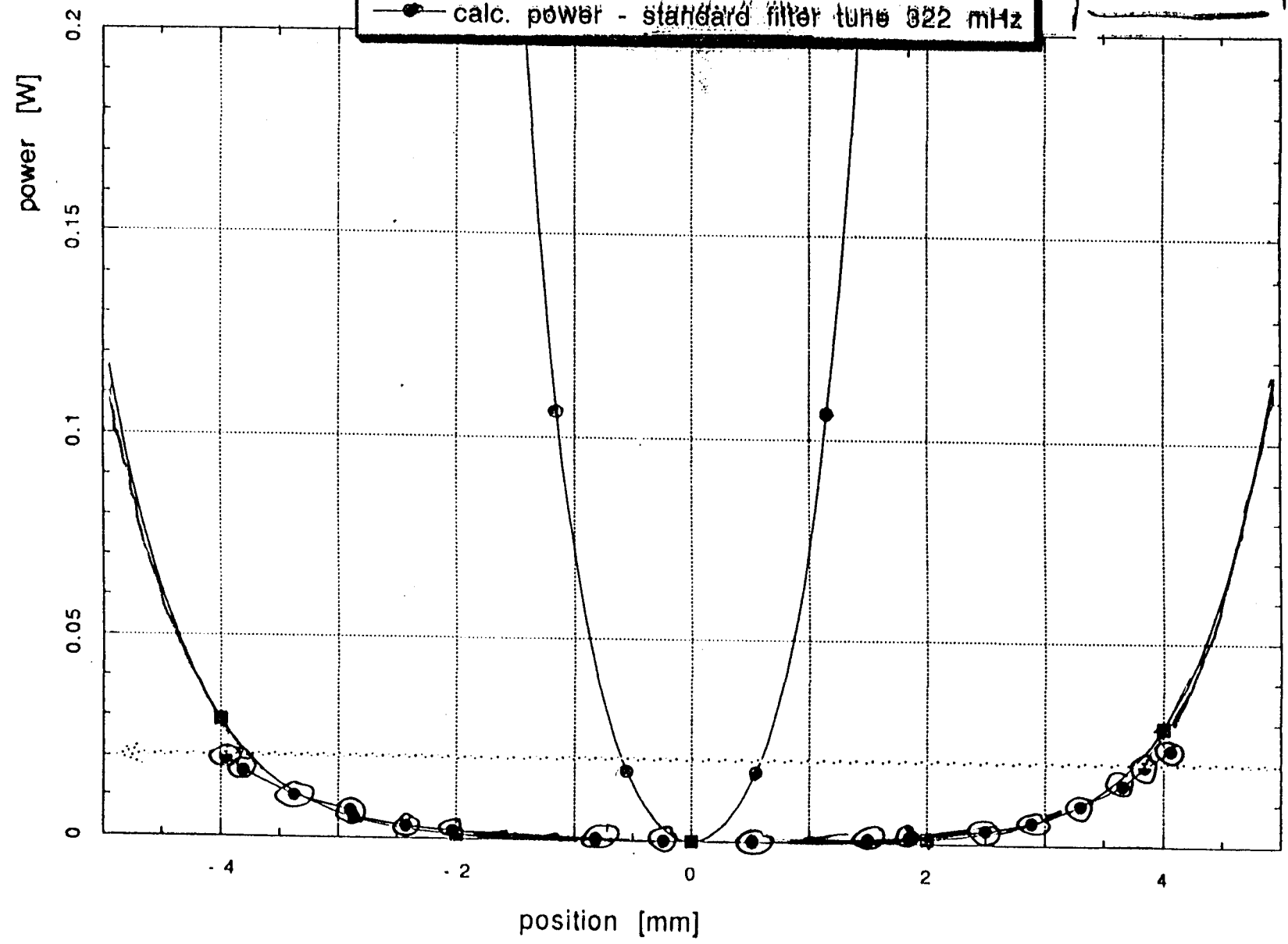

FIG. 7



F003time

$\tau = 109 \text{ sec}$

$F_{ob} = 47.49 \text{ MHz} \leftrightarrow F_{om} = 38.75 \text{ MHz}$

$Q_b = 29.7 \leftrightarrow Q_m = 24.2$

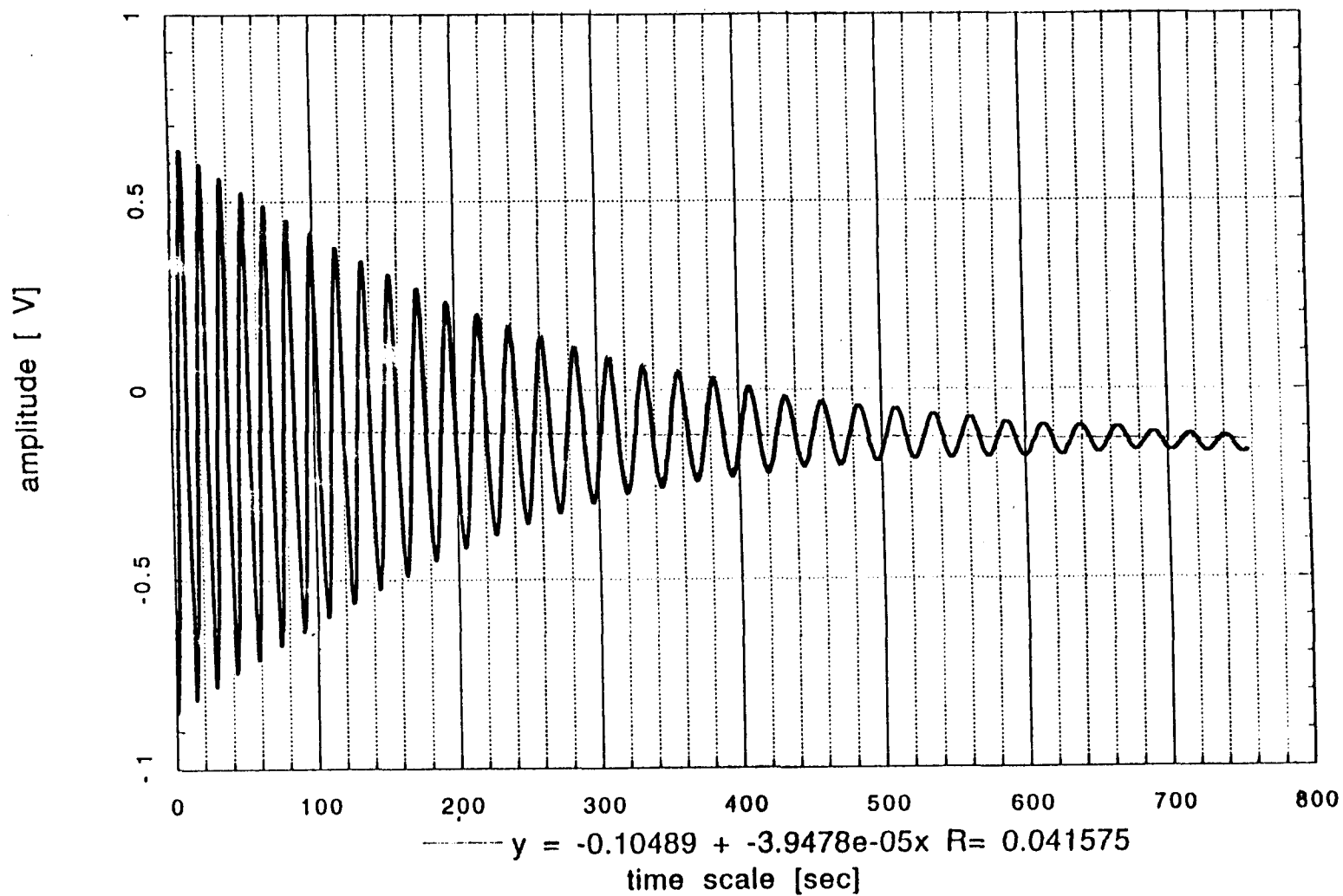

11

... of ... (dots)

FIG. 6

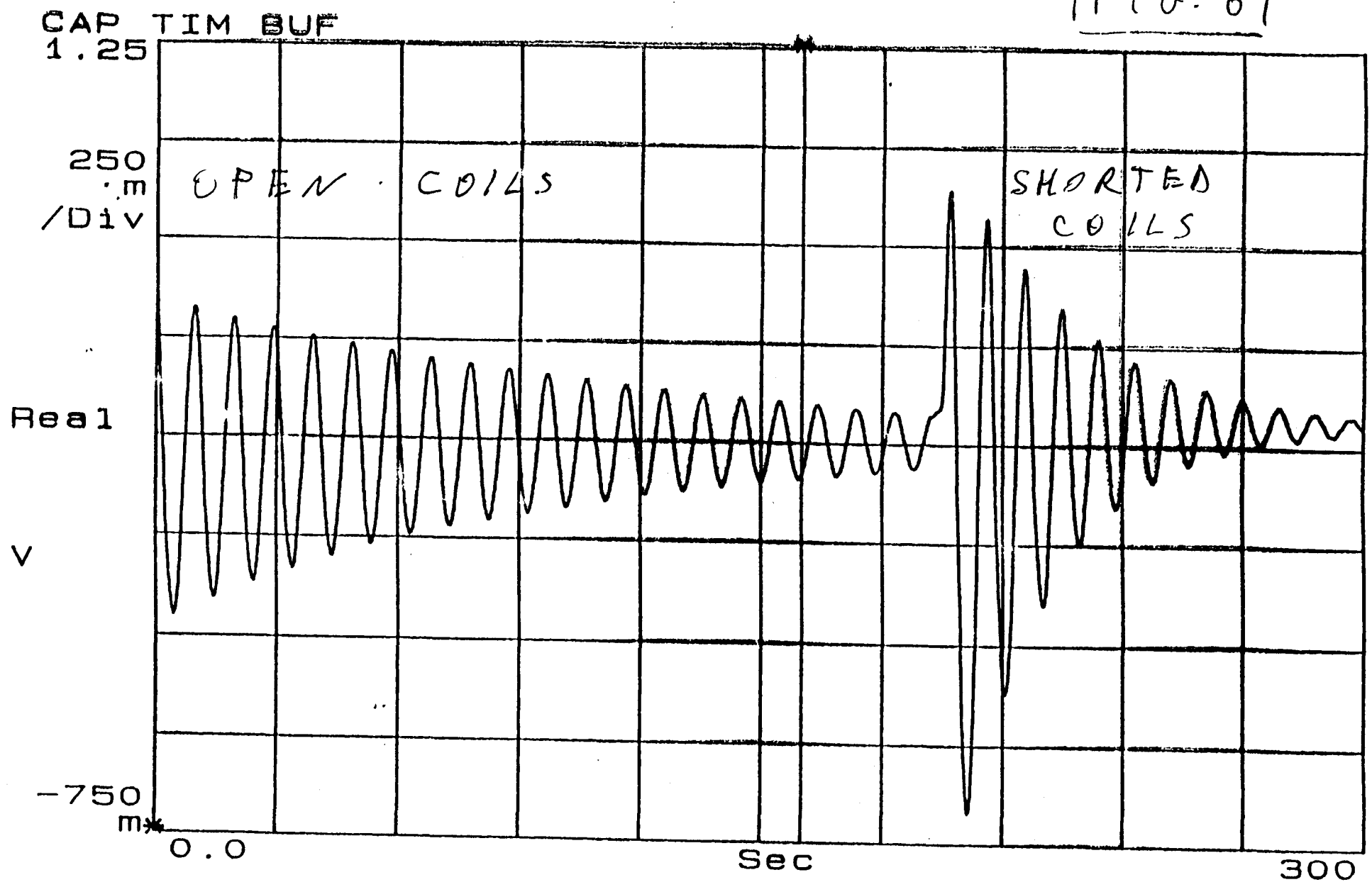

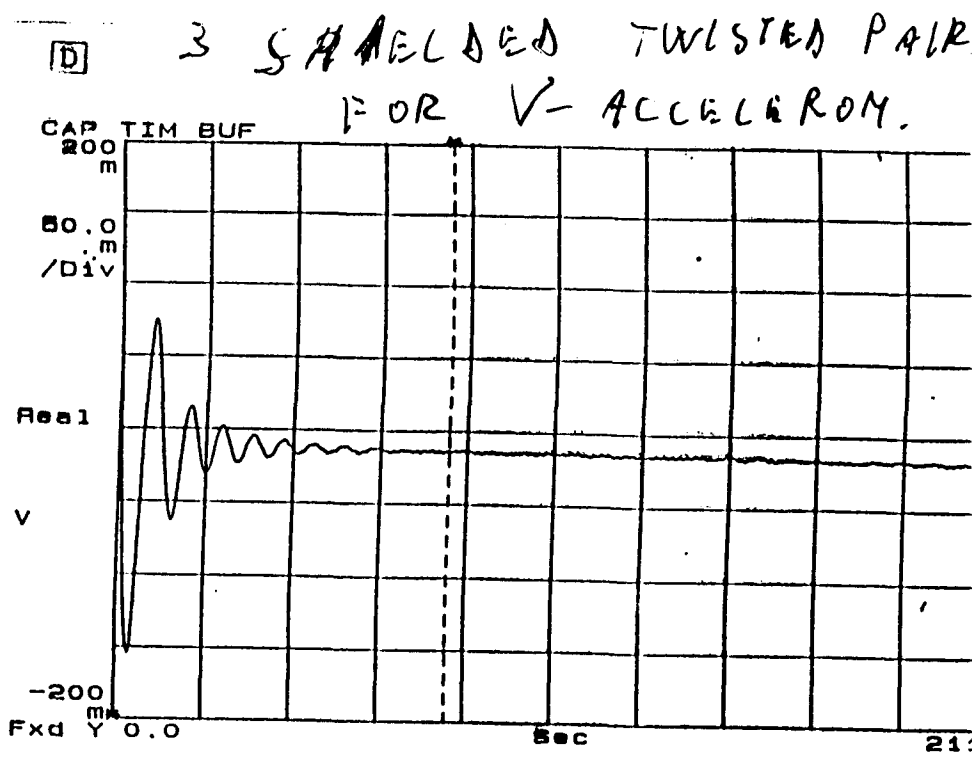
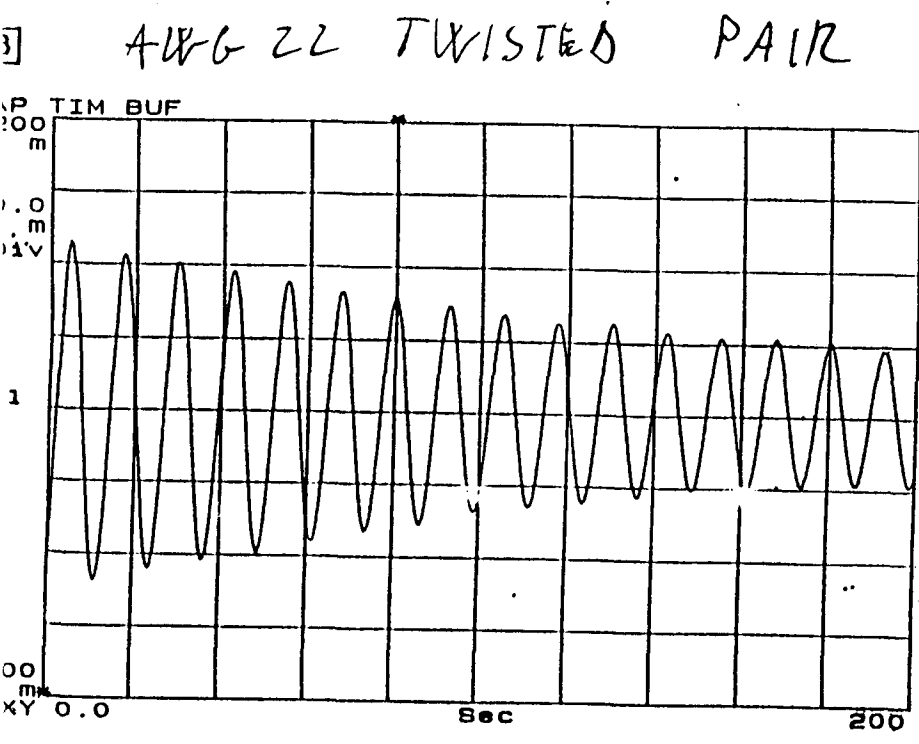
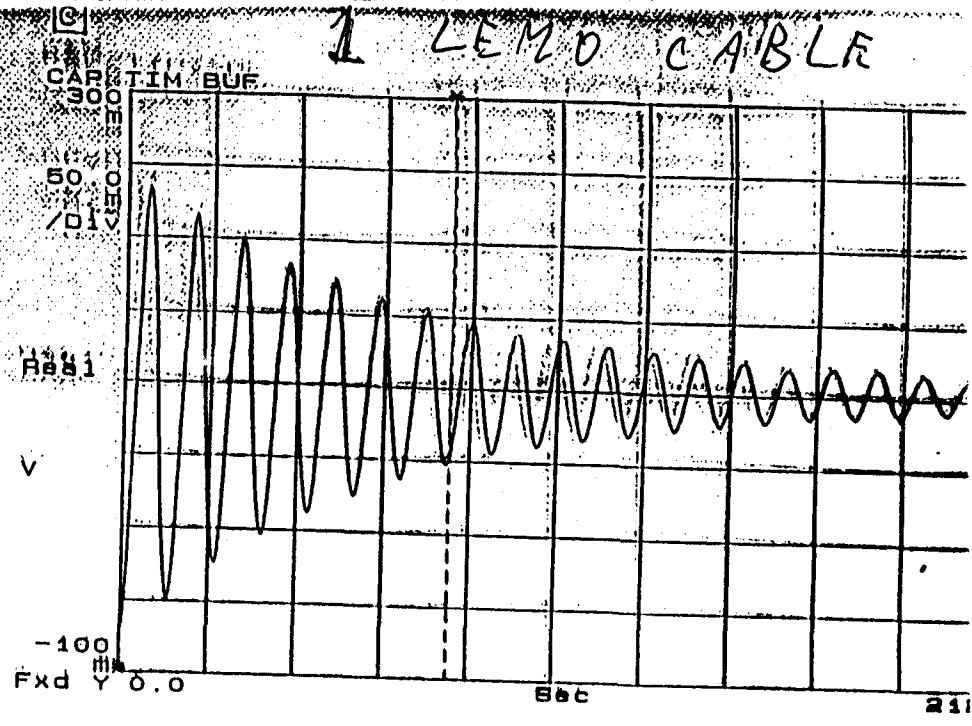
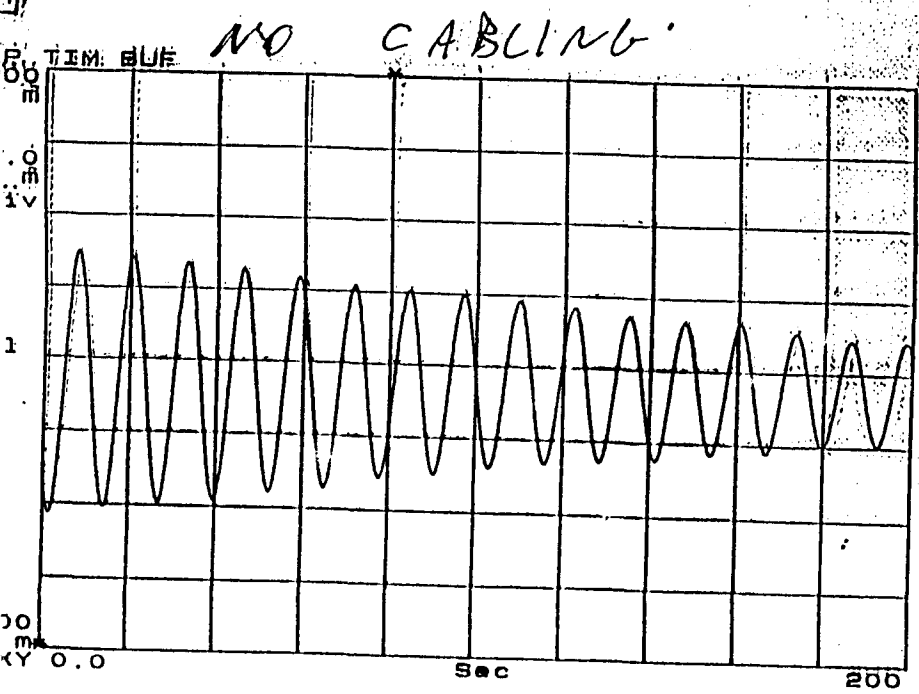

— $y = -19.81 + 0.99262x$ $R = 0.99277$

— $y = 188.17 + 0.45645x$ $R = 0.92017$

QeTau/Fo

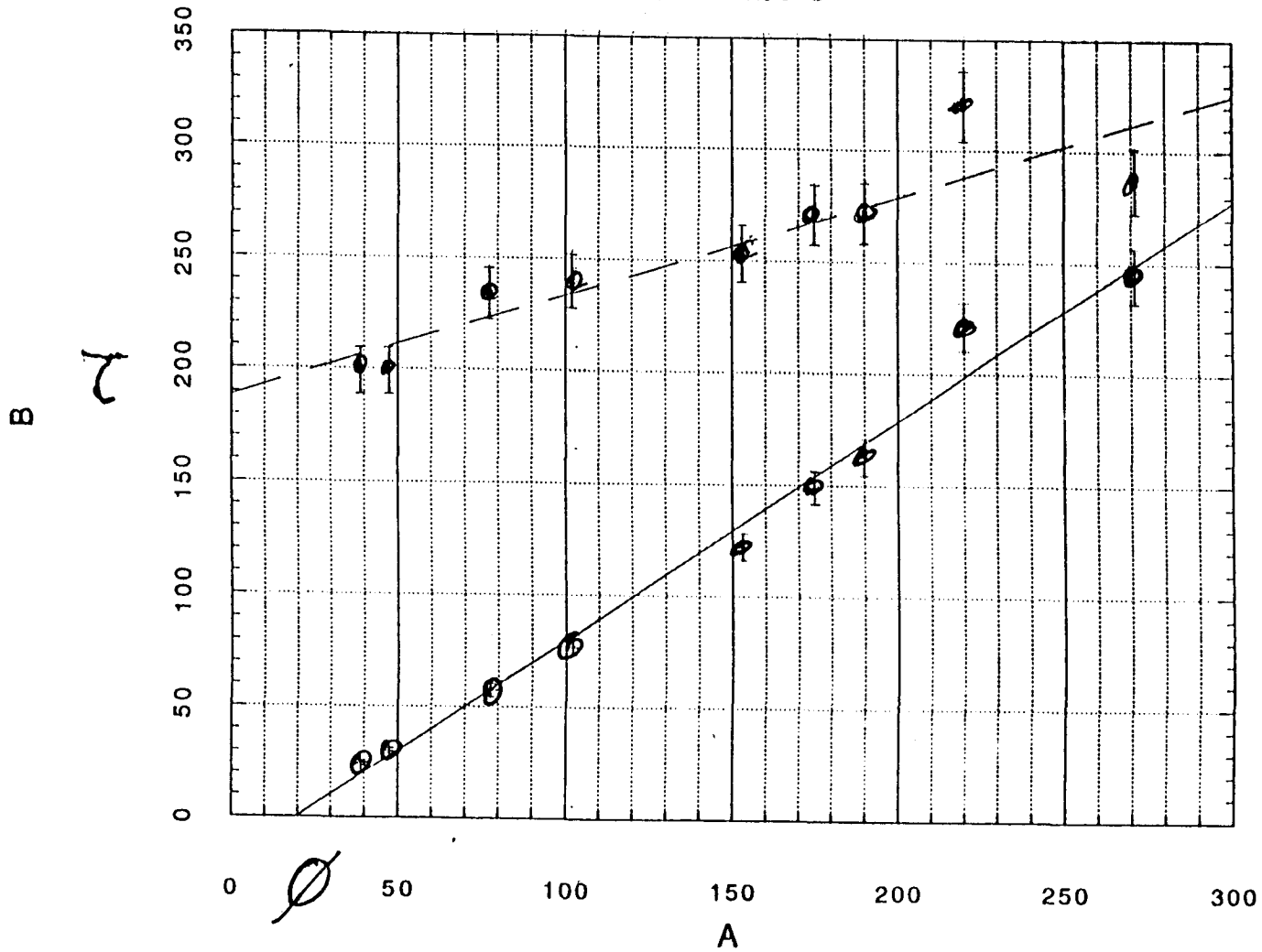

tutti dati
F#0 vecchi e nuovi

70 cm

30

F#7

on MARGING BLADES

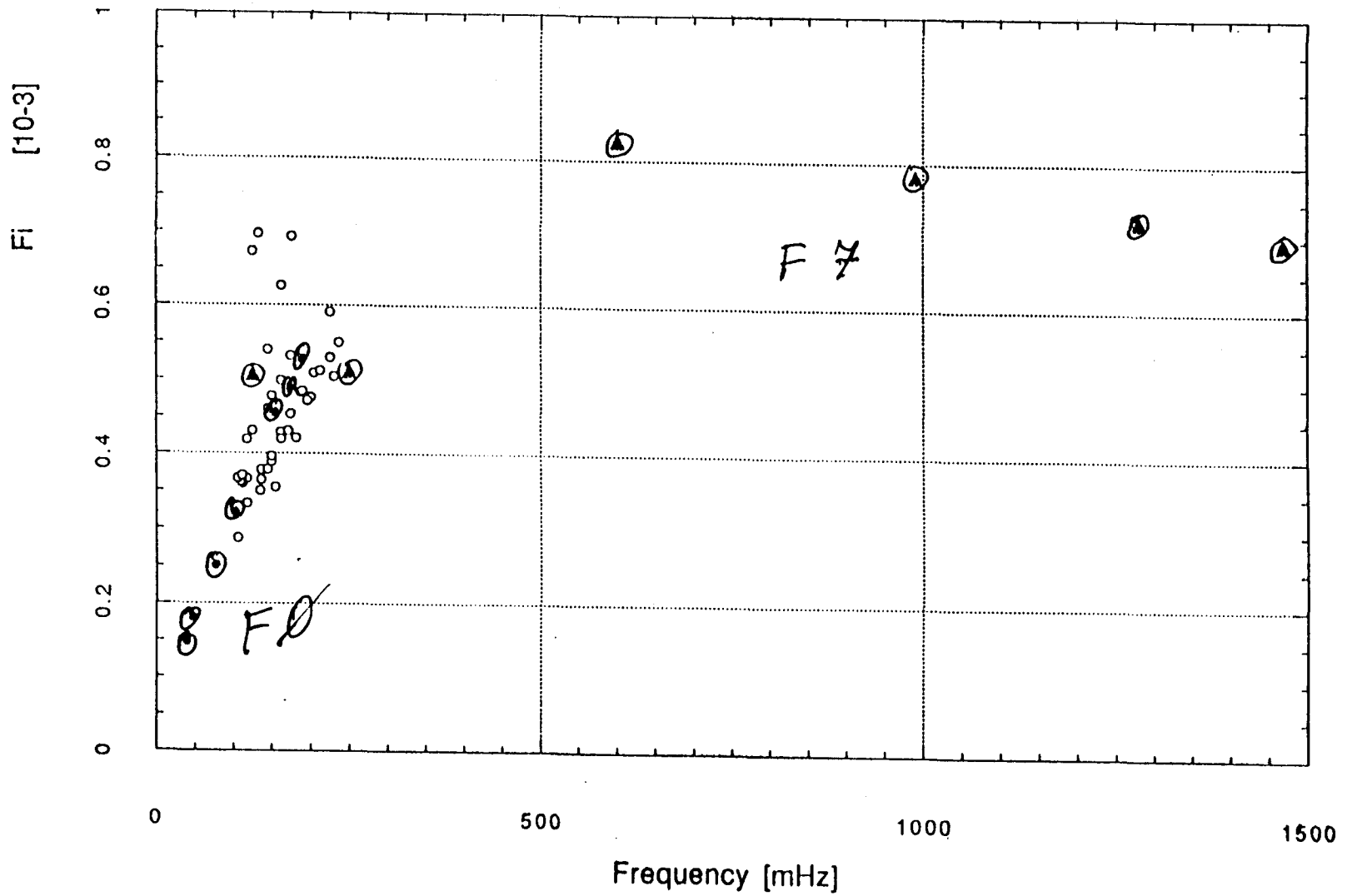

FIG. 3

X=34.25 Hz
Ya=-91.528 dBVrms

Y=-129.96 dBVrms

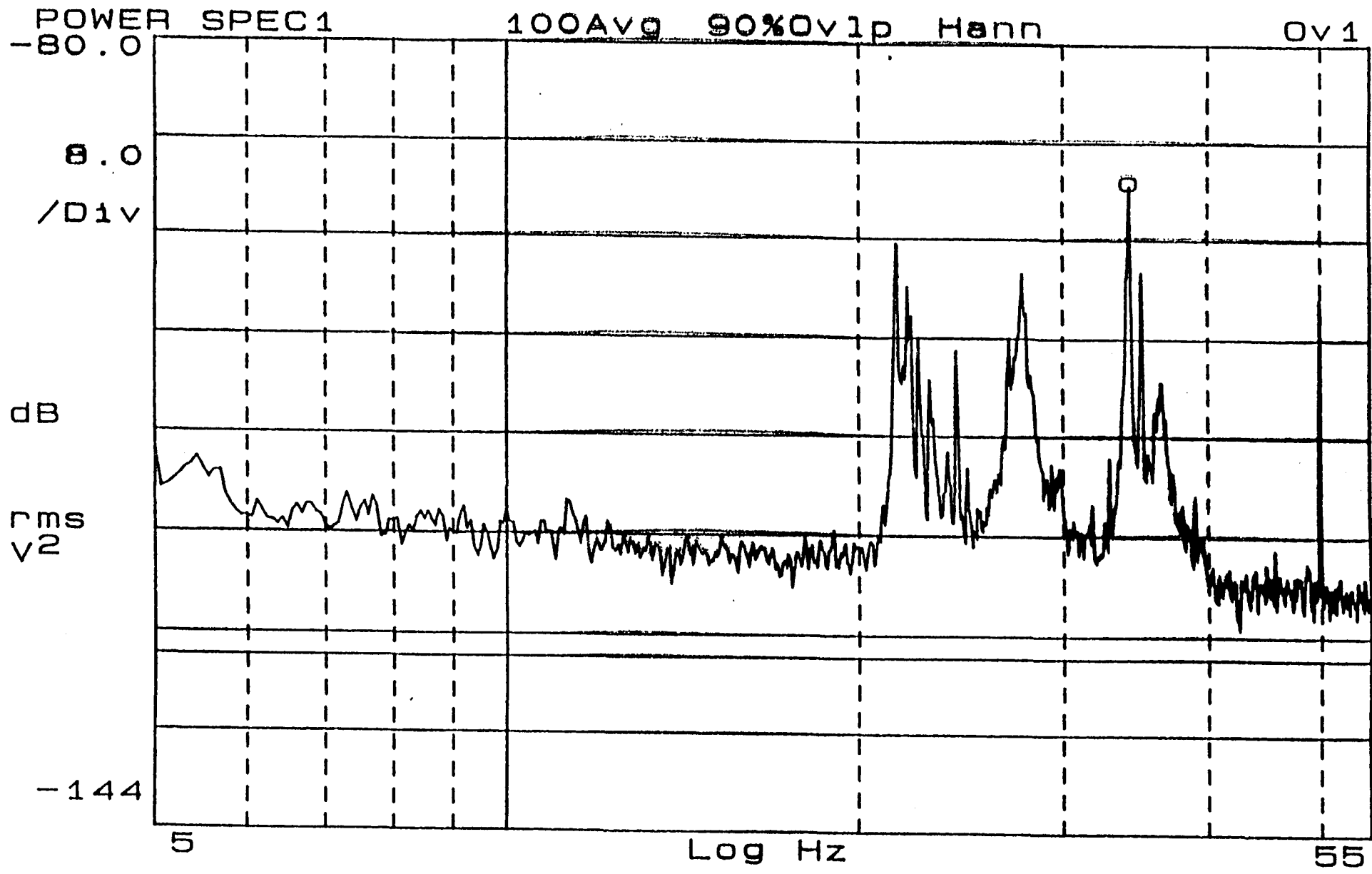
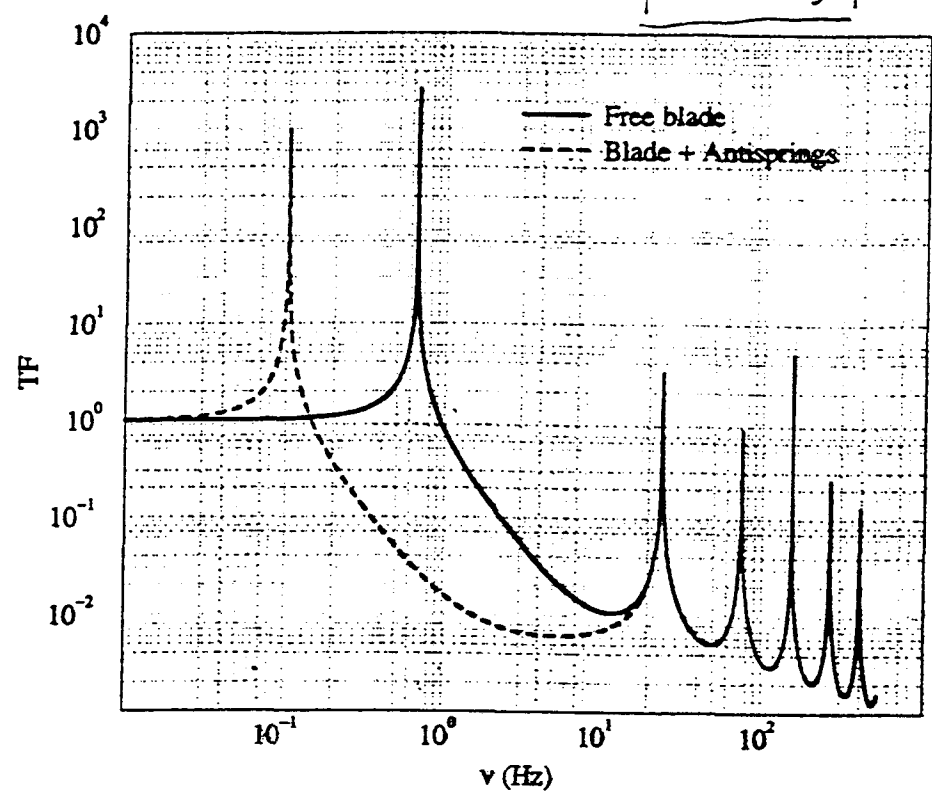

FIG. 9



transfer function of filter 0 - no1

FIG. 8

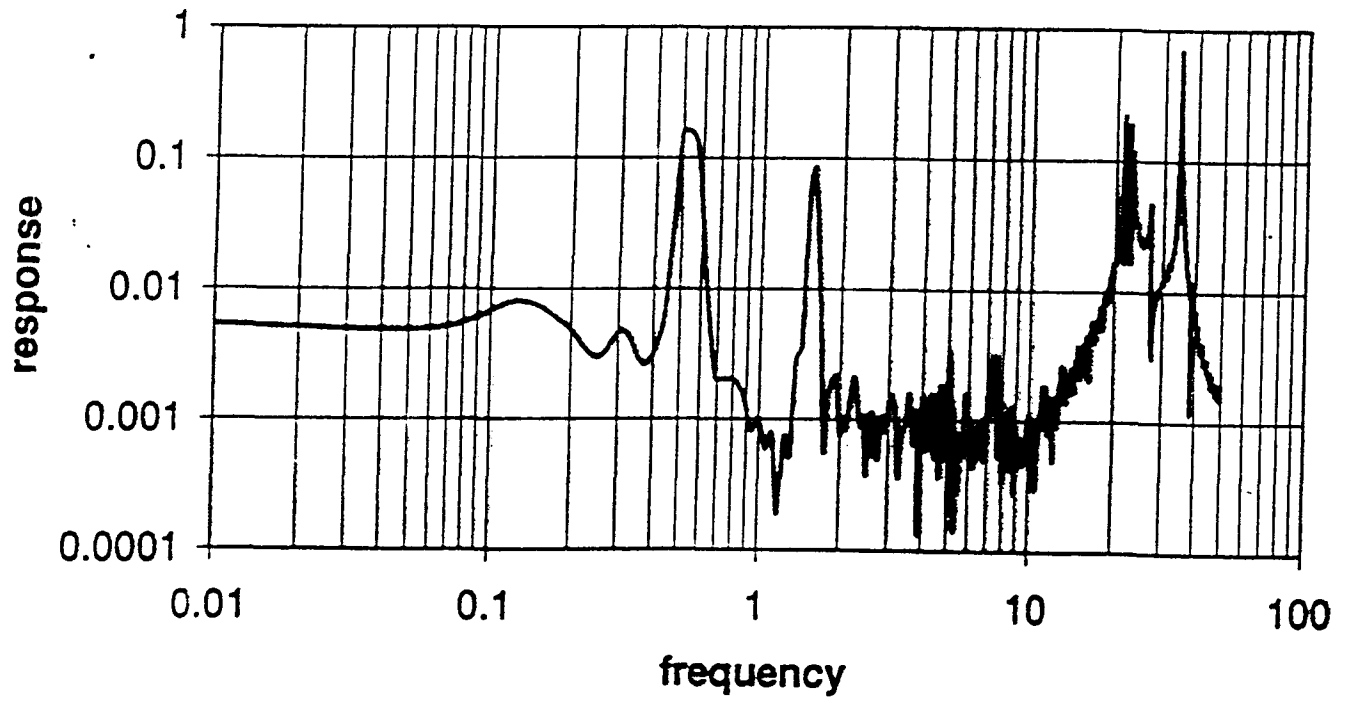
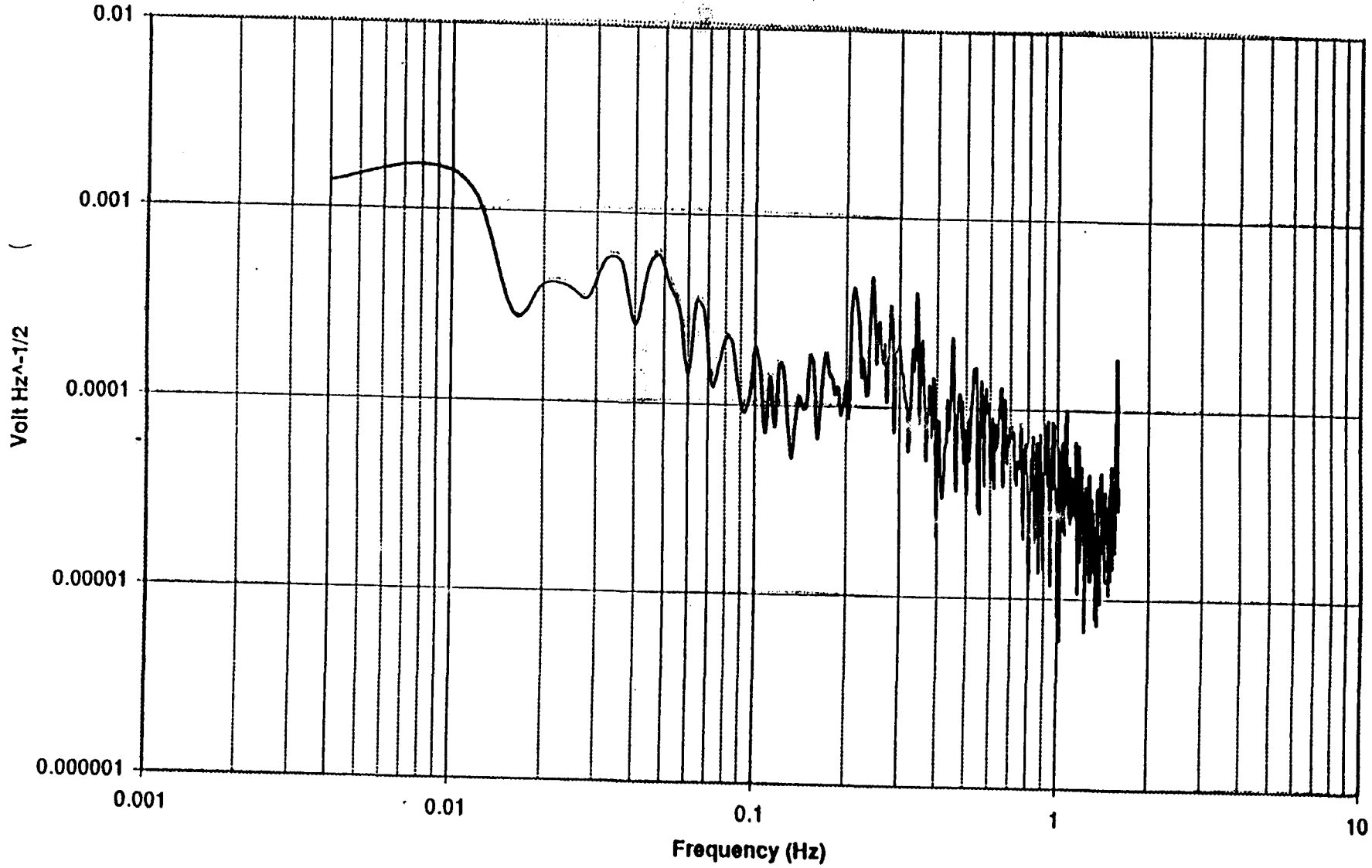

FIG 13

Filter Zero Prototype
Accelerometer Response With Feedback On



← F. B. →

1-5-63

TF from Vessel to Cross

FIG. 16

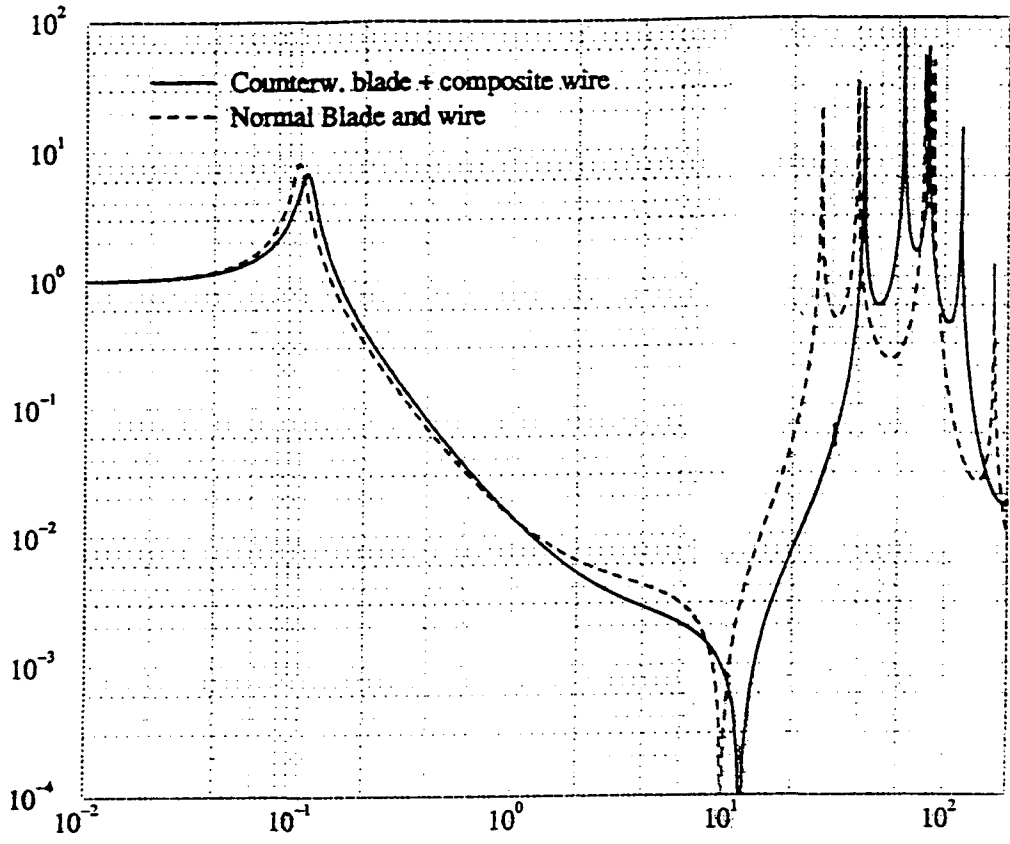
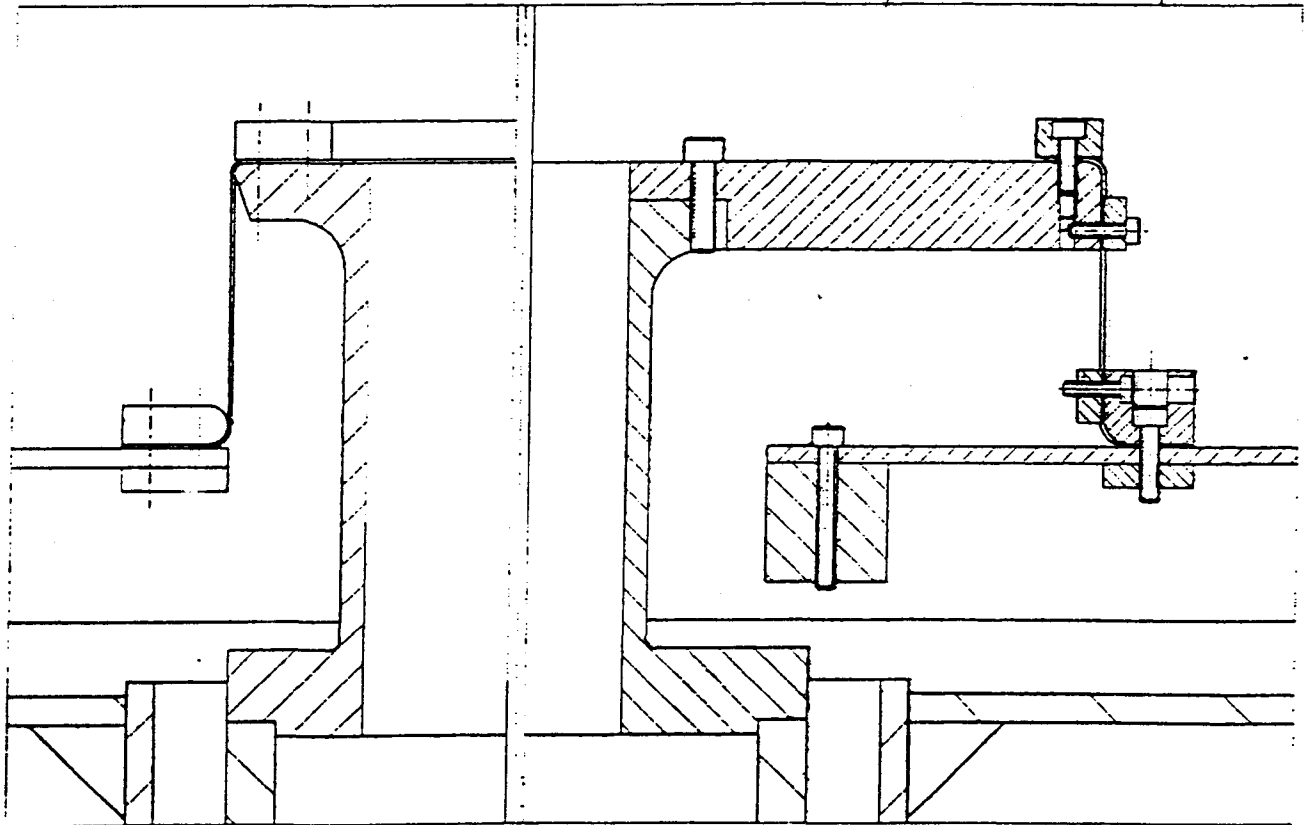
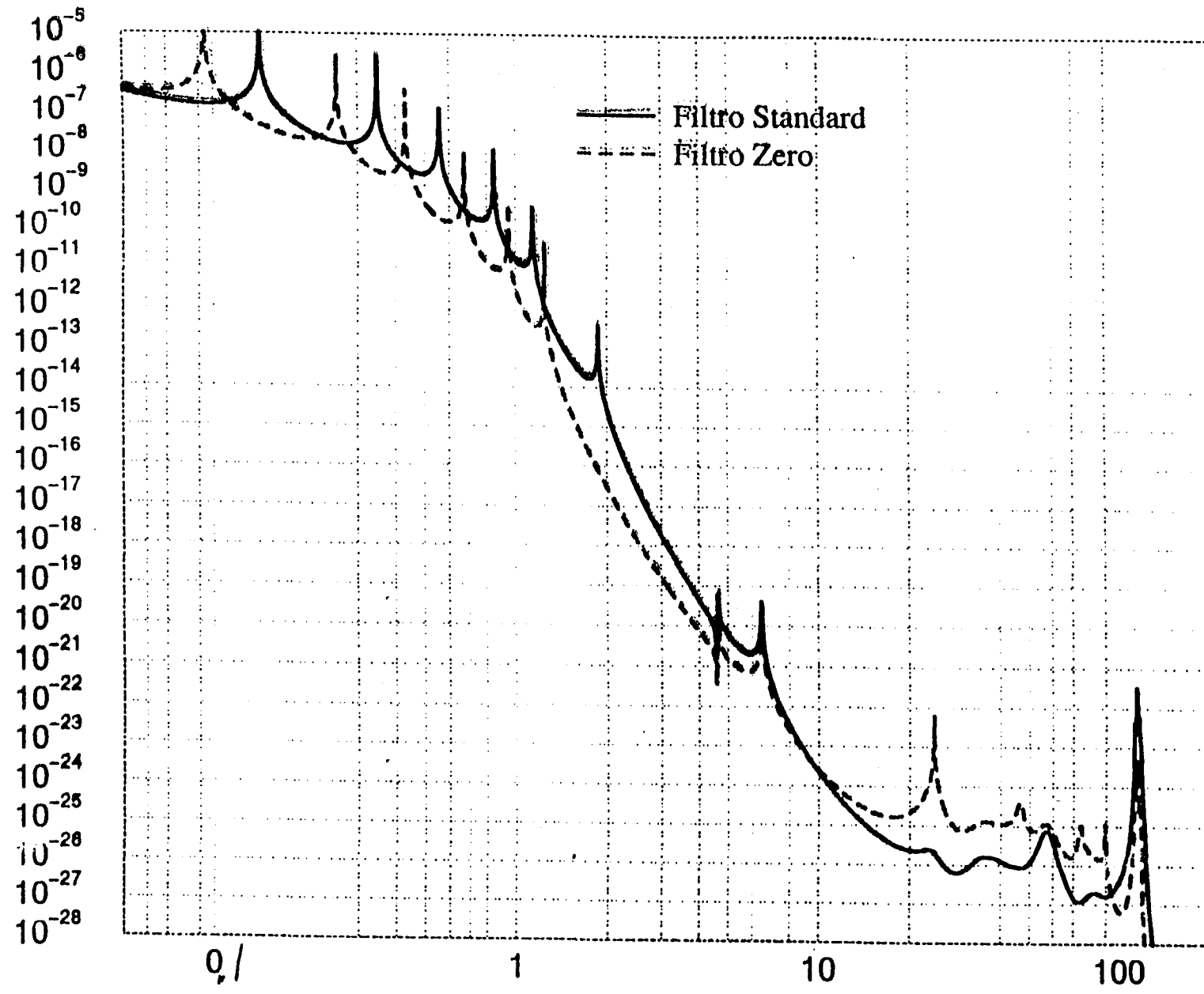
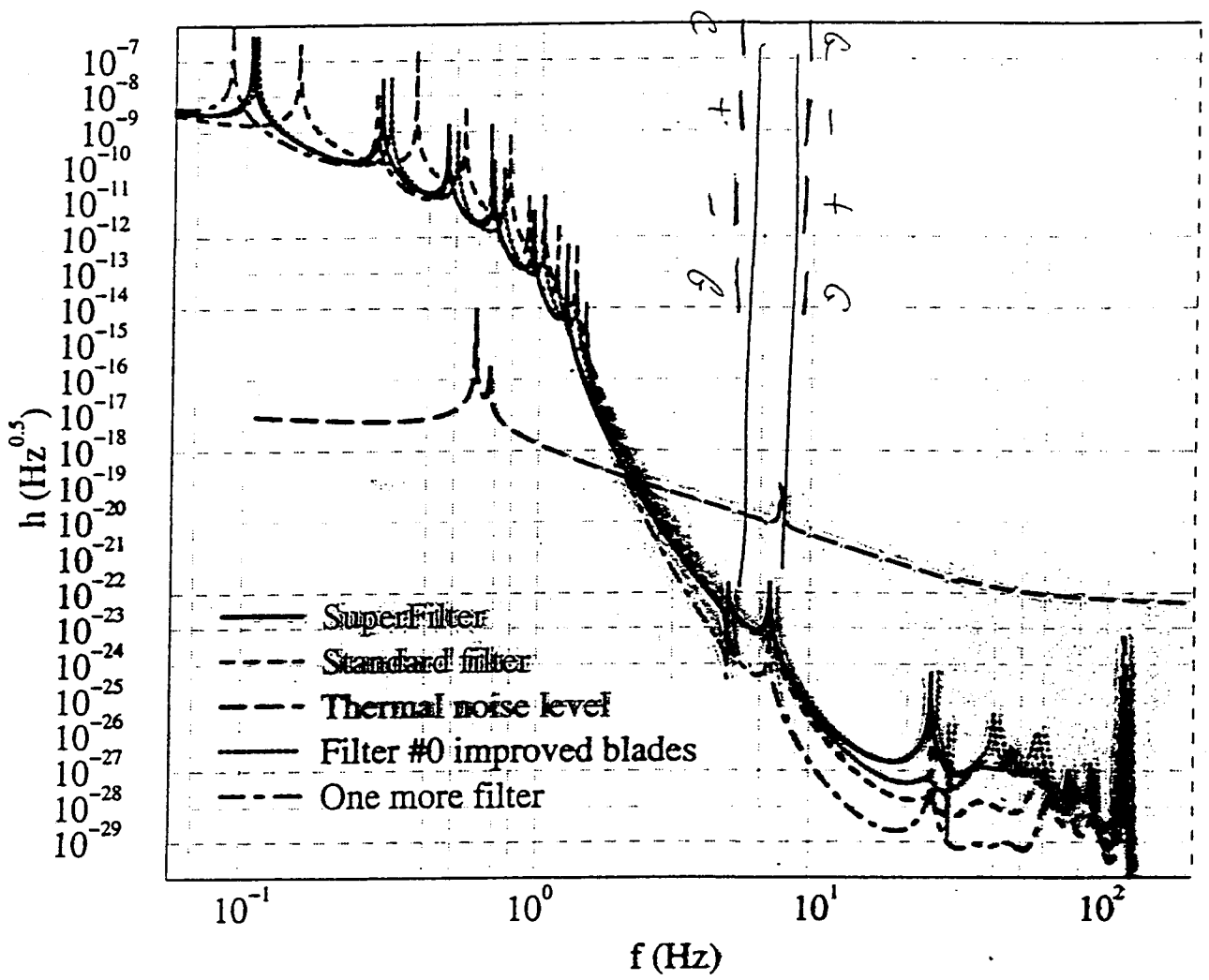

FIG 14





Rumore in h



Tutte le soluzioni sono il livello di rumore termico atteso, ma è possibile che i livelli delle risonanze siano errati.

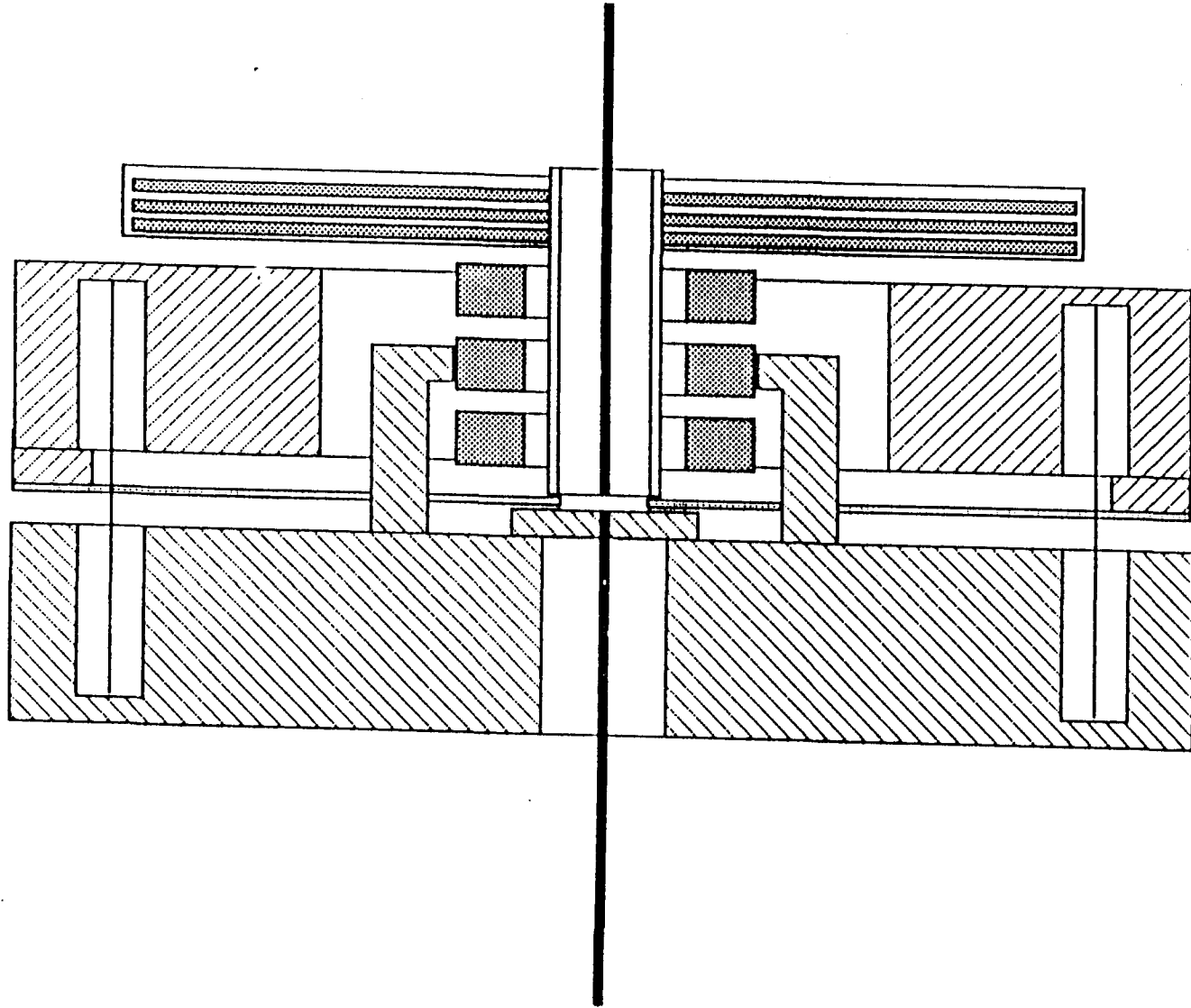

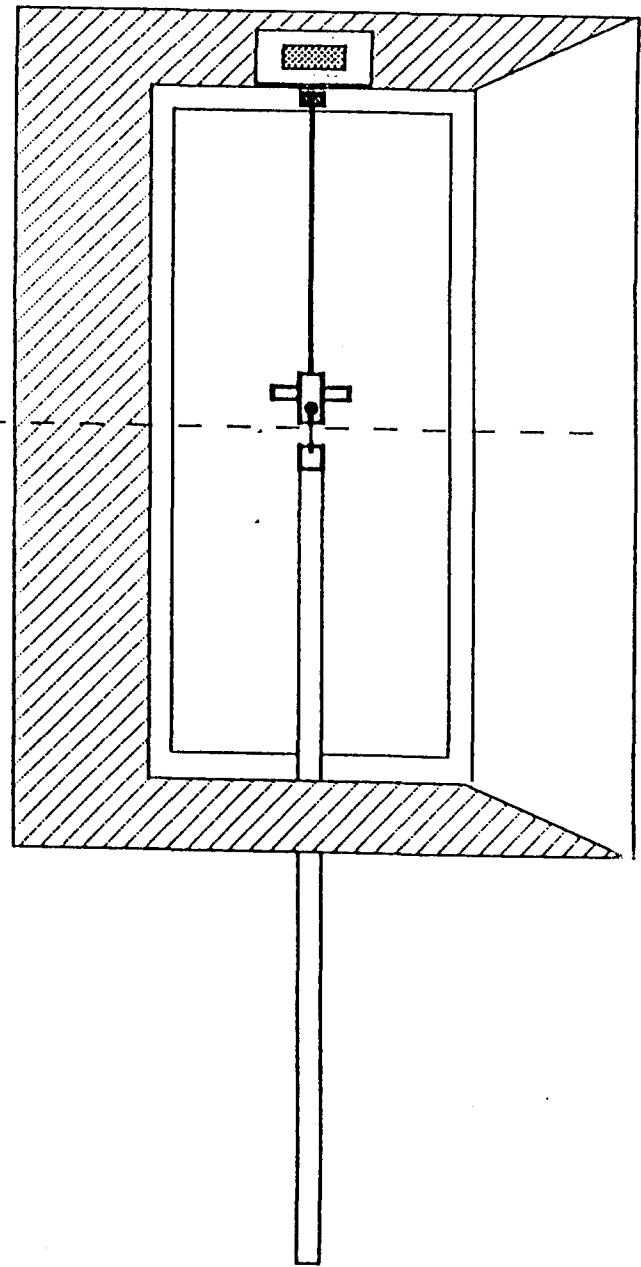
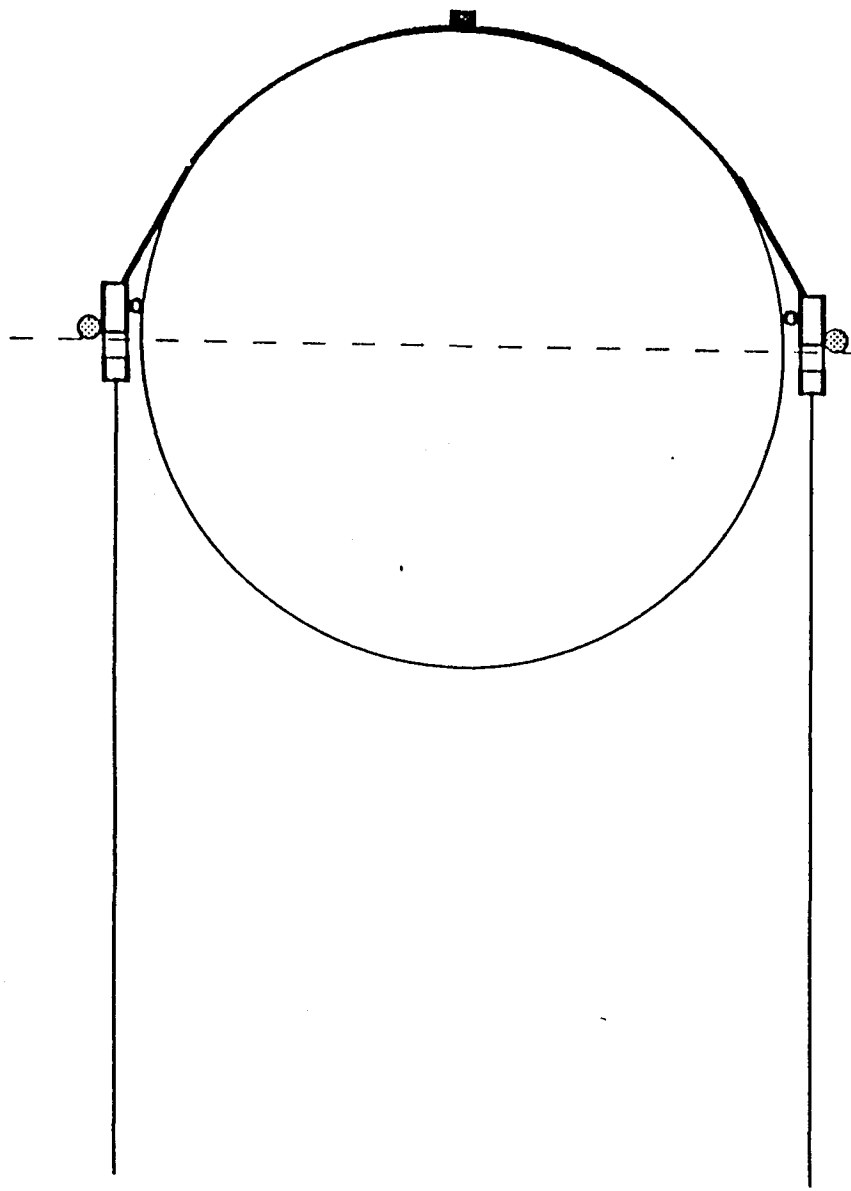

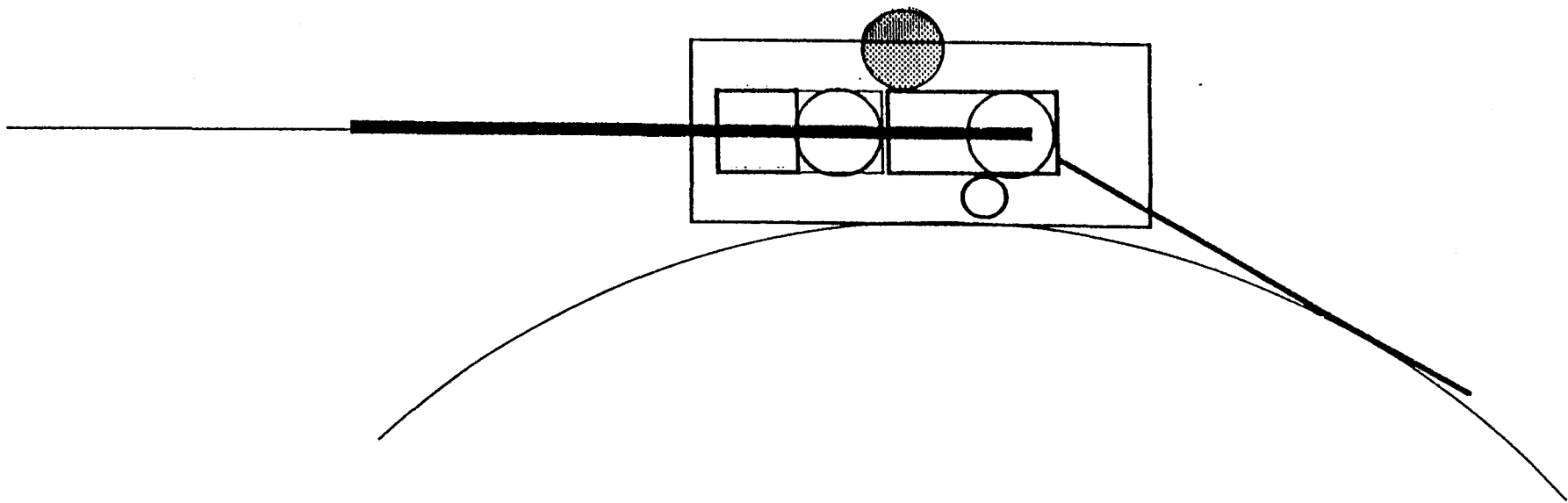

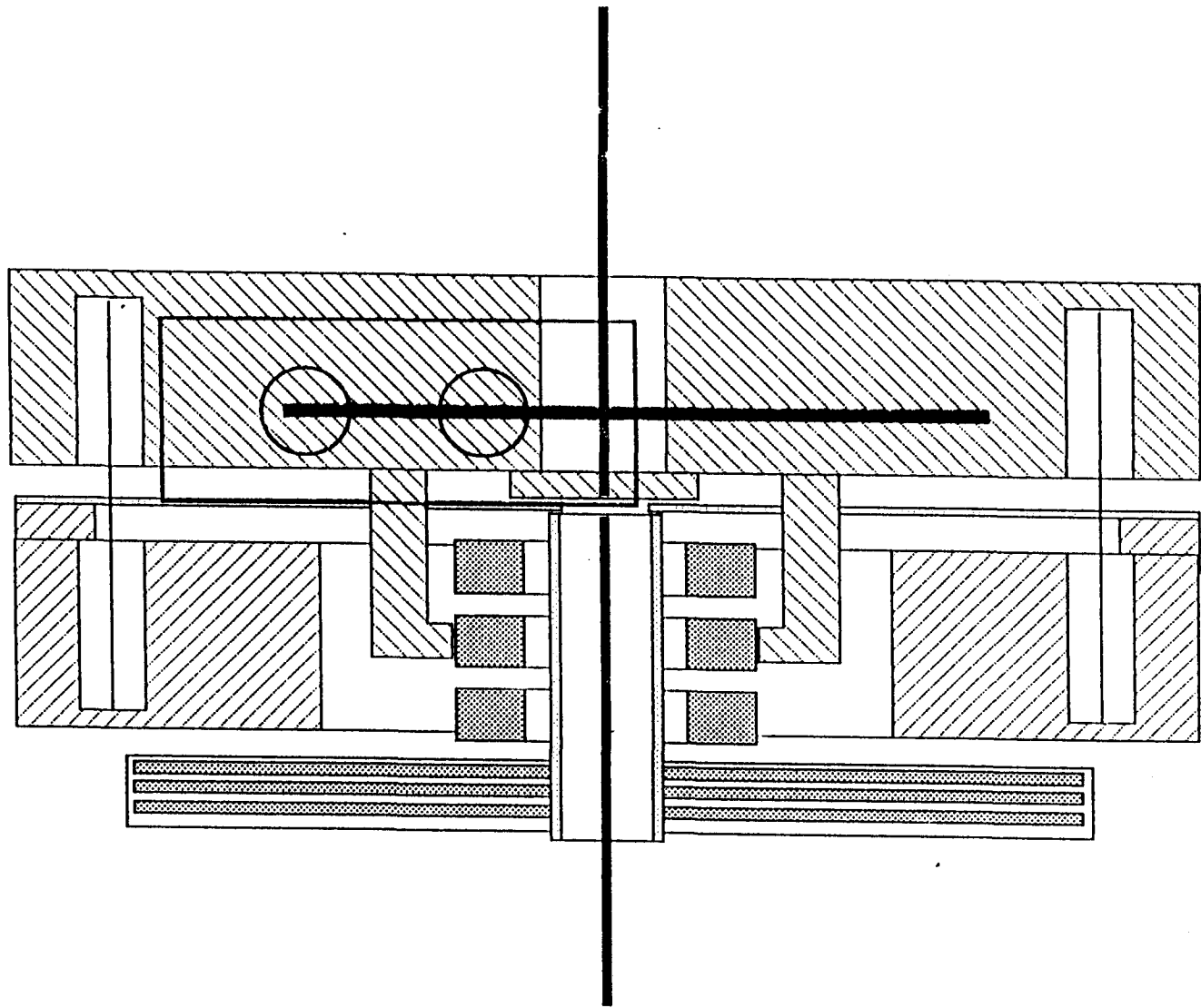

Neutronised State

- Fe
- ◐ Co
- Ti

