

LASER INTERFEROMETER GRAVITATIONAL WAVE OBSERVATORY
- LIGO -
CALIFORNIA INSTITUTE OF TECHNOLOGY
MASSACHUSETTS INSTITUTE OF TECHNOLOGY

Document Type LIGO-T970151-C - D 7/14/00
ASC Initial Alignment Procedures
K. Mason, M. Zucker

Distribution of this draft:

Detector Group

This is an internal working note
of the LIGO Project..

California Institute of Technology
LIGO Project - MS 51-33
Pasadena CA 91125
Phone (818) 395-2129
Fax (818) 304-9834
E-mail: info@ligo.caltech.edu

Massachusetts Institute of Technology
LIGO Project - MS 20B-145
Cambridge, MA 01239
Phone (617) 253-4824
Fax (617) 253-7014
E-mail: info@ligo.mit.edu

WWW: <http://www.ligo.caltech.edu/>

1 SCOPE

The purpose of this document is to establish the procedures and specify the equipment required to initially align the core optic and detector subsystem components. The procedures described are used to align the core optics on the 2 km arms at the Hanford, WA site and the 4 km arms at both the Hanford and Livingston, LA sites.

Offset centerlines will first be established parallel to the X and Y arms of the interferometer at the corner, mid, and end stations. Optical tooling techniques will then be used to translate these offset centerlines parallel to the beam tube centerline.

Establishing offset centerlines offers two main benefits:

1. Beam tubes can be installed and pumped down prior to the rest of the system being installed and aligned.
2. Future alignment or alignment verification can be done with the beam tubes closed off.

Alignment of each core optic consists of 3 adjustments. They are:

1. Transverse and vertical positioning which will be accomplished by moving the LOS until a set of fiducials are sighted with a theodolite.
2. Axial positioning (along the beamline) which utilizes the electronic distance measurement feature on the theodolite.
3. Angular alignment in which the optic will be oriented by autocollimation.

2 REQUIREMENTS

Initial alignment must set the Nd Yag laser beam within the range of adjustment of the COS such that a transition to acquisition alignment can take place. The specifications required for this to occur is specified in LIGO - T970060-00-D (1):

Angular positioning	+/- 0.1 mrad (ITM, ETM,BS, RM, FM)
Transverse positioning	+/- 1 mm (ITM, ETM)
	+/- 5 mm (BS, RM, FM)
Axial positioning	+/- 3 mm (ITM, ETM,BS, RM, FM)

The angular alignment phase is most critical due to the long length of the arms, as well as the relatively small range of adjustment of the suspended optics (0.8mrad pk/pk). Our goal for angular alignment is 10% of the adjustment range of the suspended optic or .08 mrad. Over a 4 km arm length, a .08 mrad angle will bring us within 320mm to the center of our ETM (See fig. 1).

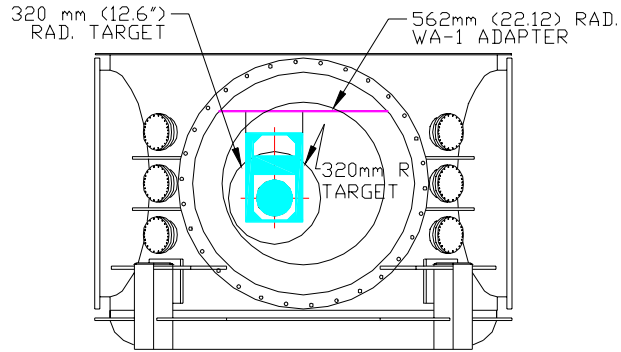

FIG 1. VIEW DOWN END STATION

The Monuments placed as of this date has been found to be within ± 3 mm by Roger's surveying (2). Over a 200 meter separation this results in an error of up to .03 mrad. The total error accumulation including monument locations, procedural and equipment errors is within our goal of .08 mrad as shown in Table 1.

Table 1: Total Error Accumulation

Positioning of monuments	.03 mrad (6 arc seconds)
Sighting of plumb markers	.02mrad (4 arc second)
90 degree autocollimation	.01 mrad (2 arc seconds)
90 degree rotation	.01 mrad (2 arc seconds)
Autocollimation of optic	.01 mrad (2 arc second)
<i>Total</i>	<i>.08 mrad (16 arc seconds)</i>

3 EQUIPMENT REQUIRED

The following equipment or their equivalent will be required:

1. One (1) Sokkia Total Station Theodolite model SET2B with electronic distance measurement (EDM), autocollimating eyepiece, tripod, prism, and optical plummet (pictured below with Newport laser autocollimator).
2. One (1) Brunson model 75-H Optical Transit Squares with autocollimating eyepiece, stand, and coincidence level (pictured below).
3. One (1) Newport laser autocollimator Model LDS1000 with mounts to theodolite.
4. Two (2) 101mm dia. optical flats with mounts (Newport #4024OBD.1 & SL101.6).
5. One (1) 4.0" dia pyrex flat, 1/20 wave, double surface parallel to 1 sec, Al Si O coating both sides. Davidson #D617-4P1P
6. One (1) 12.0" PLX Lateral Transfer Hollow Retroreflector # L-20-1-15.75E
7. One (1) 12.0" PLX Lateral Transfer Hollow Periscope # P-20-1-15.75E
8. One (1) 200mm dia optical flat and mount Davidson #D617-8P2S, Al Si O 1 side.
9. One (1) 200 ft steel tape and tension scale BMI 2473W200T.
10. One (1) Brunson Instrument stand #230-HC and one (1) model 810 stand.
11. One alignment fixture #D980001-A-D with EDM prism and scale.
12. Support stand to bridge conduit & piping LIGO dwgs. D980431 thru D980434.

75-H Optical Transit Square

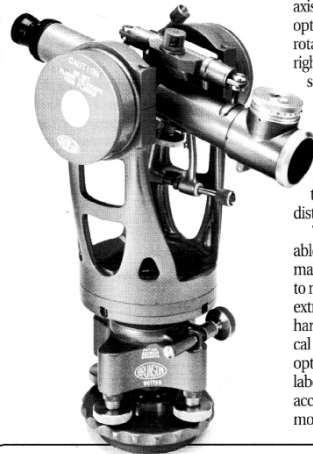

One of Brunson Instrument Company's technological breakthroughs was the development of the see-thru hollow horizontal axis on the model 75-H. A partially coated, optically flat mirror is mounted inside and rotates with the hollow axis. This provides a right angle check of the telescope's line of sight relative to the horizontal axis. Additionally, the hollow axis allows you to view the mirror from either side of the instrument to turn optical right angles. The hollow axis gives you the power to use several instruments on the same optical reference line without disturbing their positions.

The model 75-H possesses the remarkable ability to "prove" each shot as it is made, removing any possibility of error due to maladjustment from rough handling, extreme temperature changes and other harsh environmental conditions. Now optical technicians no longer need to rely on the optical bench of some distant calibration laboratory. They can verify the instrument's accuracy themselves where it counts the most — ON THE JOB.

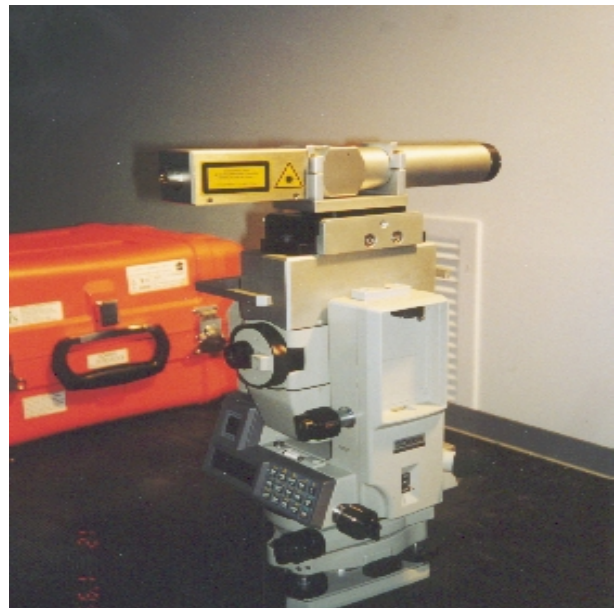

4 CALCULATED OPTIC AND THEODOLITE POSITIONS

Offset centerlines with a clear line of sight are located parallel to the beam tube centerlines in the corner, mid and end stations (see fig 3). These are defined as IAM monuments on drawings D970210 shts 1-5 for Hanford (4) and D980499 shts 1-5 (5) for Livingston. The positional accuracy of the initial alignment monuments must be within +/- 3mm of true position in Ligo Global Coordinates. This applies to X and Y position only.

The Z position is determined from actual positions of door flange centerlines. Scribes are located at each Ham and BSC door locations. The positions of these scribes are measured relative to a control point. For Hanford this control point was 1.0572 meters above BTVE1. The amount of translation required (Z_{offset}) is the difference between the calculated design values and the actual locations of the scribes. A scale is placed on the door flange such that the theodolite can measure directly the Z height. Table 2 contains scribe positions in local coordinates for the Hanford corner station as measured by Rogers Surveying.

Table 2: Elevation Scribe Positions

<i>MONUMENT</i>	<i>ELEVATION</i>	$Z_{actual} (M)$	$Z_{design} (M)$	$Z_{(offset)} (M)$
WGV-6	100.0000 M	.0033	0.0	.0033
WGV-8	99.9719	-.0248	-.0282	.0034
WHAM1	99.9128	-.0839	-.0870	.0031
WHAM-2	99.9028	-.0939	-.0955	.0015
WHAM-4	99.9014	-.0953	-.0994	.0041
WHAM-6	99.9004	-.0963	-.0993	.0030
WHAM-7	99.8823	-.1144	-.1177	.0033
WHAM-9	99.8931	-.1036	-.1076	.0040
WHAM-10	99.8933	-.1034	-.1054	.0020
WHAM-12	99.8952	-.1015	-.1055	.0040
WBSC-2	99.9996	.0029	.0006	.0023
WBSC-4	99.9937	-.0030	-.0053	.0023
WBSC-7	99.9935	-.0032	-.0052	.0020
WBSC-8	99.9993	.0026	+.0005	.0021
WBSC-8 SW	99.9975	.0008	+.0005	.0003

Table 2: Elevation Scribe Positions

<i>MONUMENT</i>	<i>ELEVATION</i>	$Z_{actual} (M)$	$Z_{design} (M)$	$Z_{(offset)} (M)$
LBSC-1	-	-.007	-.001	.006
LBSC-2	-	-.014	-.001	.013
LBSC1-1	-	-.011	-.002	.009
LBSC1-2	-	-.012	-.002	.009
LBSC1-3	-	-.014	-.004	.010
LBSC1-4*	-	-.010	-.004	.006
LBSC3-1*	-	-.013	-.003	.010

* Indicates preferred monument

There are several factors which effect the Z-position and pitch of the optics. The curvature of the earth and physical orientation of the beam tube have to be factored into the setup parameters.

The beam tube orientation and earth curvature add to give the difference between global and local coordinates. This angle was calculated by Albert Lazzarini in Ligo-T980044 (6) from best fit survey data. The curvature of the earth puts our bubble levels at different angles to the straight line formed by the beam tube. We therefore add this constant angle to our beam tube orientation to properly position the theodolite. This data is summarized in table 3. The total angular compensation is added to the pitch orientation of the theodolite.

Tables 4 and 5 contain optic positions per Ligo-T970091 (3) and theodolite/autocollimator positions and orientations. The theodolite/autocollimator data was found by taking the surface normals for each of the optics (T970091) and extending the vector until it intersected the plane created by the off-set centerlines (fig 2). This data includes compensations for curvature of the earth and physical orientation of the beam tubes.

The height of the theodolite does not include the offset distance between the theodolite and the autocollimator and the actual Z scribe reference. The theodolite separation can change therefore must be measured and then subtracted from the value given in tables 4 and 5 column 8.

e.g. In setting the Hanford MMT3 optic the measured separation was 153.2 mm and we used the scribe on WBSC-8 SW.

Therefore $Z_{final} = Z_{theo} - Z_g - Z_{sep}$

$$Z_{final} = -19.135 \text{ mm} - .30 \text{ mm} - 153.2 \text{ mm} \quad Z_{sep} = \text{measured distance}$$

$$Z_{final} = -172.6 \text{ mm} \quad Z_{theo} = \text{value in table 5}$$

$$Z_g = \text{value in table 2}$$

Table 3: Global Direction Cosines

	<i>CORNER</i>	<i>MID STATION</i>	<i>END STATION</i>
X-ARM WA	-619 microrad	-305.83 microrad	7.84 micro- rad
Y-ARM WA	12.5 microrad	325.84 microrad	639.20 microrad
X-ARM LA	-312 microrad	-	314.7 microrad
Y-ARM LA	-611 microrad	-	18.77 microrad

Fig.3. LLO Scribe Locations

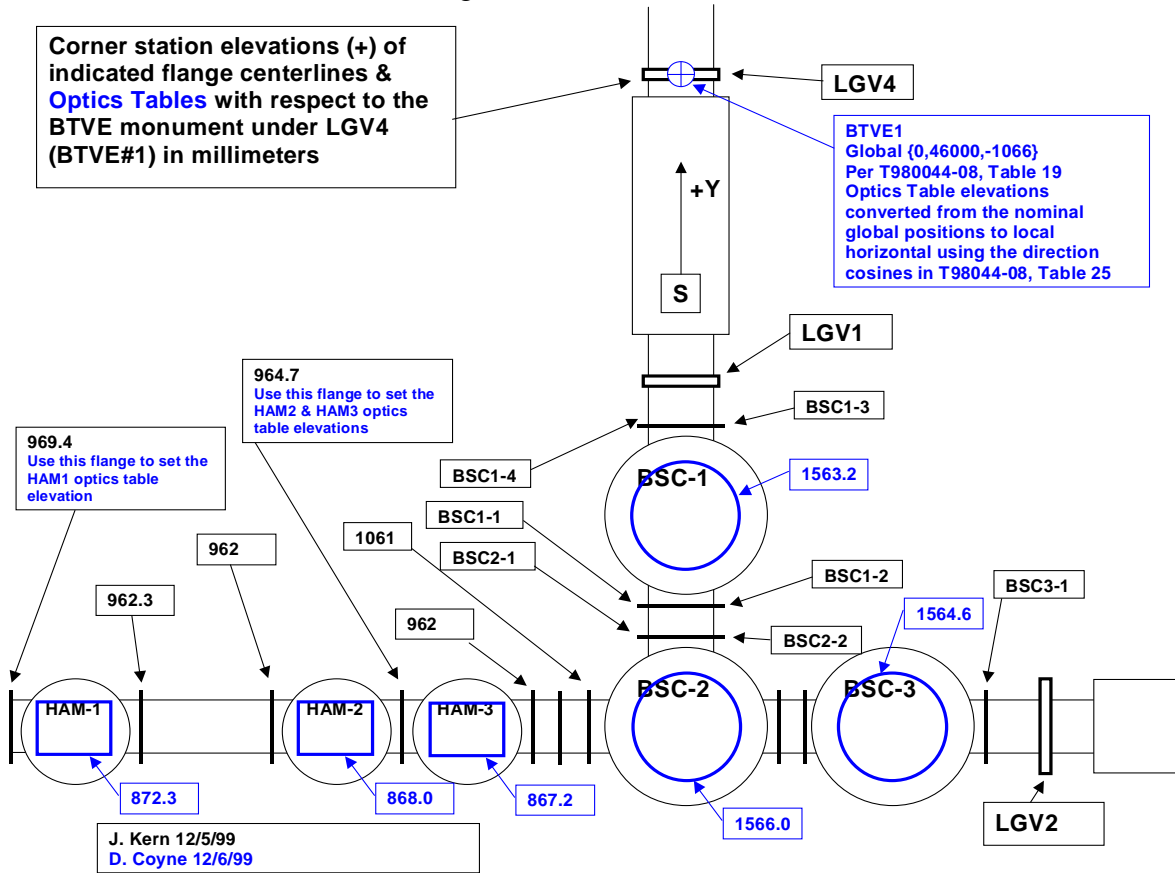

Table 4: OPTIC AND THEODOLITE POSITIONS (2K)

Optic	<u>X</u> optic	<u>Y</u> optic	<u>Z</u> optic	<i>Monu- ment</i>	<u>X</u> the- odolite	<u>Y</u> the- odolite	<u>Z</u> theod- olite	<u>Yaw</u> theodo- lite	<u>Pitch</u> theodo- lite	Axial dis- tance
LIGO GLOBAL COORDINATES							LOCAL COORDINATES			
MMT3	29510.7	9062.1	43.1	IAM13	-3251.1	9305.2	19.13	90°25'30	89°55'23	32763
RM	12184	9060	43	IAM14	-3251.1	9060	-246.8	89°59'32	88°57'9"	15438
RM(a)	12184	9060	43	IAM14A	-3251.1	8657.8	-246.8	89°59'32	88°57'9"	-
OF _y	1614	9072	-95.0	IAM26	-3251.1	9072.1	-108.0	89°59'4"	89°50'43	-
OF _{y(a)}	971.6	9678.8	-96.7	IAM82	-3251.1	7895.3	-96.5	67°29'42	90°0'0"	-
FM _y	199.6	9072.4	-96.3	IAM29A	200.9	38154	-2.4	270°0'7"	90°11'23	29082
FM _{y(a)}	199.6	9072.4	-96.3	IAM81A	-3251.1	9707	-84.7	89°59'16	90°9'58"	-
ITM _y	199.6	9569.1	-98.1	IAM29	199.6	38154	-98.5	270°0'0"	90°0'2"	28585
ETM _y	199.6	2018689	-98.1	IAM121	199.6	2012861	-100.0	270°0'0"	89°58'52	5828
OF _{bs}	10184	9060	-13.2	IAM27	-3251.1	8660.7	-103.8	270°0'0	89°38'24	-
BS _(2k)	9162.6	9059.6	-14.0	IAM32	9163	-3251.2	9.3	270°0'4"	90°9'47	12311
OF _x	9166.2	400	-103.7	IAM32A	9164.4	-3251.2	-121.4	270°1'41	89°48'38	-
FM _x	9162.6	-199.6	-98.4	IAM33A	38154	-186.2	-81.9	89°58'25	90°2'38	28991
ITM _x	9686.6	-199.6	-100.3	IAM33	38154	-199.6	-123.0	0°0'0"	89°57'52	28467
ETM _x	2018807	-199.6	-100.3	IAM131	2012860	-199.6	-98.4	270°0'0"	90°1'5"	5947

(a) designates an alternate method when the line of sight is blocked by an optic or baffle.

Table 5: OPTIC AND THEODOLITE POSITIONS (4K LIVINGSTON))

Optic	<u>X</u> optic	<u>Y</u> optic	<u>Z</u> optic	<i>Monu- ment</i>	<u>X</u> the- odolite	<u>Y</u> the- odolite	<u>Z</u> theod- olite	<u>Yaw</u> the- odolite	<u>Pitch</u> the- odolite	<i>Axial dist.</i>
MMT3	-20883.6	207.8	25.6	IAM78	11600	-8.7	-27.6	90°22'55"	89°53'42"	32484
RM	-4596.0	212.0	26.0	IAM77	11600	214.1	-283.9	89°59'34"	88°53'57"	16199
OF _{bs}	-1740.0	212.4	-27.5	IAM77	11600	214.1	-283.9	89°59'34"	88°53'57"	-
ITM _x	4669.7	199.5	-100.9	IAM76	11600	199.5	-103.1	90°0'0"	89°58'54"	6930
BS _(2k)	-199.4	212.6	-57.0	IAM90	-199.54	11600	-175.8	89°24'11"	89°59'58"	11388
ITM _y	-199.4	4805.2	-98.1	IAM91	-199.4	11600	-102.3	90°0'0"	89°57'52"	6795
ETM _y	-199.4	3999860	-98.1	-	200.6	4002365	-98.3	270°0'0"	90°0'04"	2505
ETM _x	3999725	199.5	-100.9	-	3993700	199.5	-104.6	90°0'0"	89°58'54"	6025

LIGO-DRAFT

5 2K ALIGNMENT PROCEDURES

5.1. ALIGNMENT OF MMT3 AND RM

1. Prepare vacuum equipment. Place clean rooms over WHAM 7, WHAM9 and WBSC8. Doors must be removed to allow loading of the LOS and line of sight for alignment equipment (See fig. 5)
2. Place the LOS with the MMT3 optic suspended onto the optics table in Wham7 in its approximate location (see fig 4).
3. Mount the autocollimator to the theodolite. Mount such that the adjustment screws are on the right when looking into the scope. Strain relieve the autocollimator cable to the clamp supplied.
4. Mount the autocollimator/theodolite on the Brunson stand and position over IAM 13. Level the stand with a machinist level and the theodolite with the bubble level. Using the optical plummet, center the theodolite over the monument.
5. Clamp a 300mm or greater scale to the flange protector on WBSC-8, aligning it to the scribe on the side of the flange.
6. Set the 8.0" diameter optical flat between the offset centerline and scale with the top of the mirror just above the $Z_{\text{theodolite}}$ position from table 4.
7. The theodolite and autocollimator are next set parallel to one another. To do this first autocollimate the theodolite to the optical flat using the autocollimator kit in place of the eyepiece. When autocollimated to within an arc second, adjust the laser autocollimator orientation with the upper right and lower left adjustment screws on the New Focus mount. Readings can be made by either the digital readout or by an oscilloscope connected to the analog output port on the controller for the laser autocollimator. Each instrument must be autocollimated to within 1 arc sec (5 microradians).
8. Measure the separation between the theodolite scope and the autocollimator scope and record this value. Level the theodolite 180degrees, making sure to encompass the travel the theodolite must move. Calculate the z-height per page 8 and set the crosshairs in the theodolite to the appropriate mark on the scale.
9. Rotate towards the monument IAM12 or IAM99 which establishes the offset centerline and align to the monument. Adjust for monument calibration per LIGO-T990017 (7).
10. When aligned to the monument, zero out the horizontal angle and adjust the telescope body to zero the vertical angle. Rotate in yaw and pitch per table 4. The theodolite/autocollimator is now in its final position and should not be moved again.
11. Place the scale on the fixture. With the scale in its upper locked position, the center of the optic should correspond to 6.00" on the scale. Measure off the Z separation (theodolite centerline to autocollimator centerline) on the scale and move the LOS until the theodolite crosshairs are aligned to this position and the edge of the scale.
12. Remove the scale and replace with the prism. Measure the distance to the prism adding the predetermined offset to the optic face dimension to the measurement. To convert to Ligo Global coordi-

nates subtract the x value of the theodolite (-3251.1mm) from the reading. Adjust the LOS until the correct x position is obtained per table 4.

13. Remove the prism to begin autocollimation of the optic hr surface with the laser autocollimator. Place the autocollimator in analog mode and put 2 oscilloscopes in parallel. One should be placed near the autocollimator and the other placed in sight of the person adjusting the alignment fixture.

14. There will probably be 2 reflections off the optic. Distinguish between the reflection off the HR surface and the AR surface. Locate the reflection off the HR surface and guide the reflection through the tube back toward the autocollimator. Adjust manually until a reading is made within 20 microradians. Fine adjustment can now be made by moving the permanent magnets.

15. Once the optic is in its final position, turn on the laser for the optical lever and steer the beam onto the photodetector until it is nulled out. Calibrate the optical lever per Calibration of Optical Levers, LIGO-T990026 (9).

16. Alignment of the RM is identical to MMT3 using the positions found in table 4 and positioning over IAM-14.

17. The doors are replaced and clean rooms removed.

Fig 4. Optical Table Layout

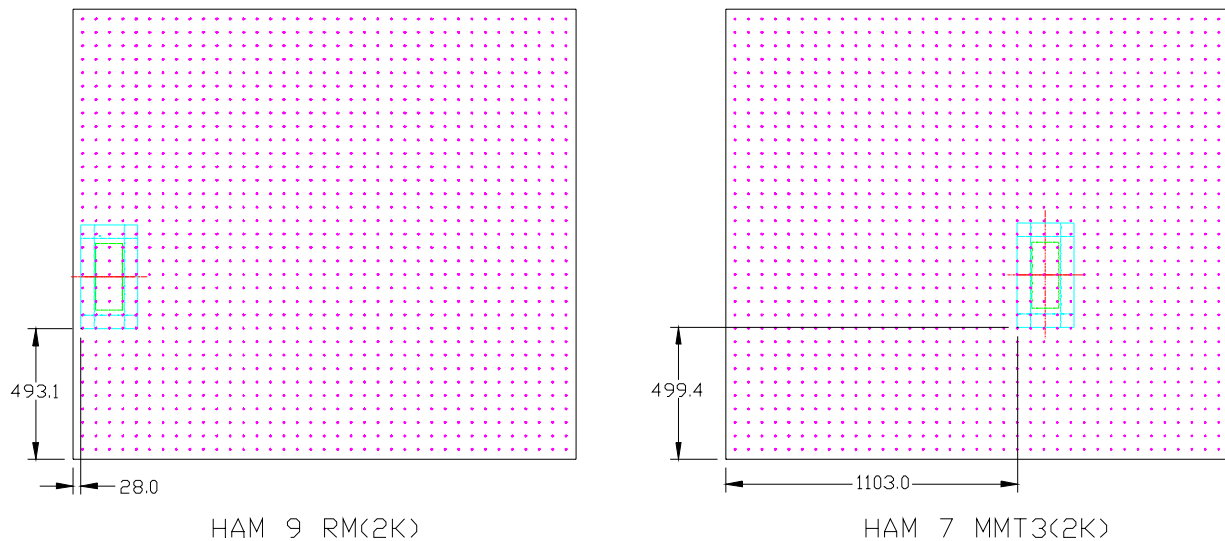

LIG

Fig. 5

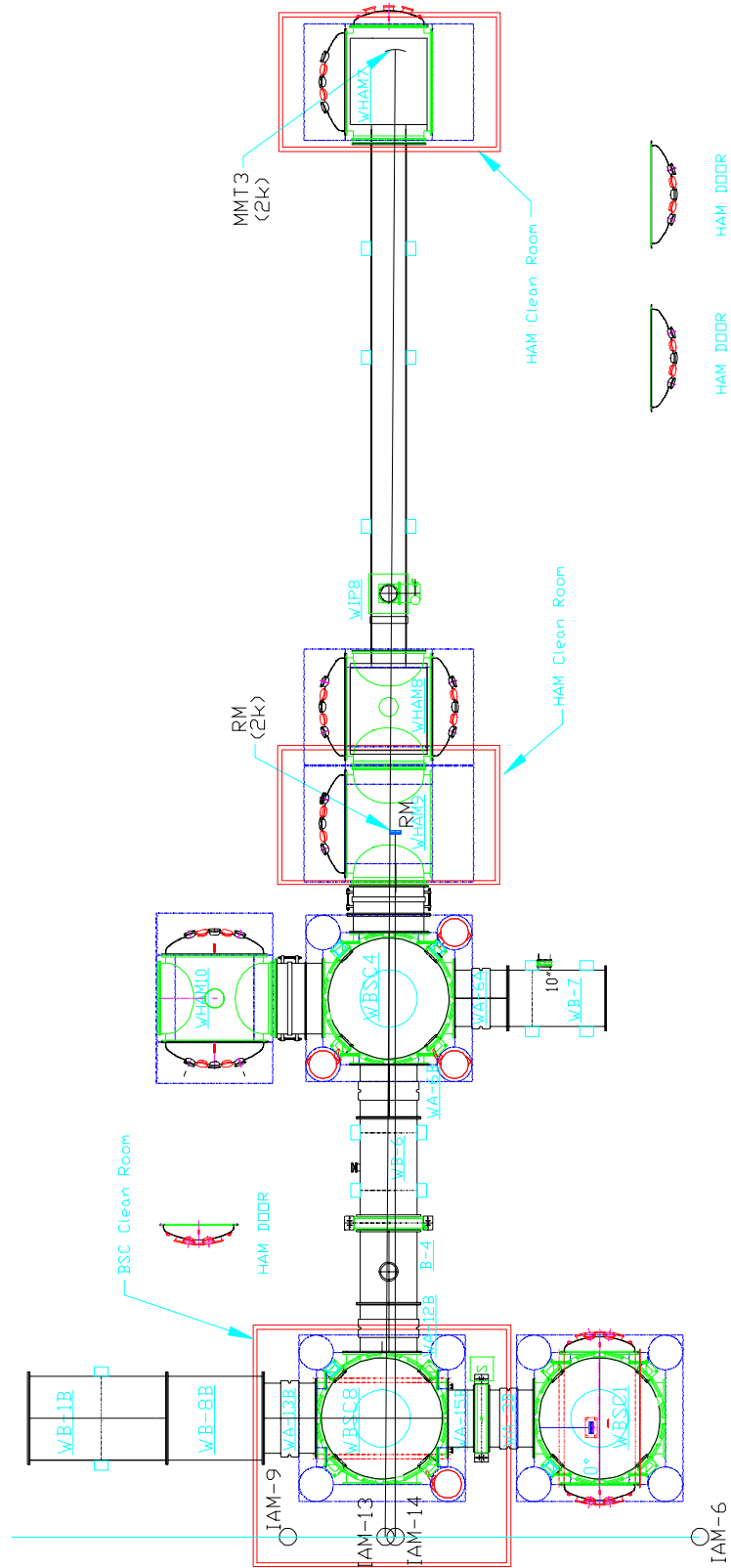

5.2. ALIGNMENT OF BEAM SPLITTER OPTICAL FLAT

1. Prepare vacuum equipment. Place clean rooms over WBSC-8 and WA-1B. Remove the door on WBSC-8 and adapter WA-1B to allow loading of the LOS and a line of sight for alignment equipment.
2. Place the optical flat and mount into adapter WA-12B in its approximate location as shown in fig.6.
3. Mount the autocollimator to the theodolite. Mount such that the adjustment screws are on the right when looking into the scope. Strain relieve the autocollimator cable to the clamp supplied.
4. Mount the autocollimator/theodolite on the Brunson stand and position over IAM 26. Level the stand with a machinist level and the theodolite with the bubble level and then internal level. Using the optical plummet, center the theodolite over the monument.
5. Clamp a 300mm or greater scale to the flange protector on WBSC-8, aligning it to the scribe on the side of the flange.
6. Measure the separation between the theodolite scope and the autocollimator scope and record this value. Level the theodolite 180 degrees, making sure to encompass the travel the theodolite must move. Calculate the z-height per page 8 and set the crosshairs in the theodolite to the appropriate mark on the scale.
7. Set the 8.0" diameter optical flat between the offset centerline and scale with the top of the mirror just above the $Z_{\text{theodolite}}$ position from table 4.
8. The theodolite and autocollimator are next set parallel to one another. To do this first autocollimate the theodolite to the optical flat using the autocollimator kit in place of the eyepiece. When autocollimated to within an arc second, adjust the laser autocollimator orientation with the upper right and lower left adjustment screws on the New Focus mount. Readings can be made by either the digital readout or by an oscilloscope connected to the analog output port on the controller for the laser autocollimator. Each instrument must be autocollimated to within 1 arc sec (5 microradians).
9. Check the separation between the theodolite scope and the autocollimator scope and record this value. Check that the theodolite is level 180 degrees, making sure to encompass the travel the theodolite must move. Recalculate, if necessary, the z-height per page 8 and set the crosshairs in the theodolite to the appropriate mark on the scale.
10. Rotate towards the monument IAM12 and IAM99 which establishes the offset centerline and align to the monument. Adjust for monument calibration per LIGO-T990017 (7).
11. Position the optical flat such that the autocollimator beam is approximately centered on the 4.0" dia. optical flat.
12. Adjust the optical flat mount until autocollimated within 1 arc sec (5 microradians).
13. The optical flat is in its final position and must not be moved or bumped.

5.3. ALIGNMENT OF THE BEAMSPLITTER

1. Prepare vacuum equipment. Place clean rooms over WBSC-4 and WBSC-8. Doors must be removed to allow loading of the LOS and line of sight for alignment equipment.
2. Place the LOS with the BS optic suspended into WBSC-4 in its approximate location as shown in fig.8.
3. Mount the autocollimator to the theodolite. Mount such that the adjustment screws are on the right when looking into the scope. Strain relieve the autocollimator cable to the clamp supplied.
4. Mount the autocollimator/theodolite on the Brunson stand and position over IAM 32 plus .7071(A) per fig.6. Level the stand with a machinist level and the theodolite with the bubble level. Using the optical plummet, center the theodolite over the monument.
5. Clamp a 300mm or greater scale to the flange protector on WBSC-7, aligning it to the scribe on the side of the flange.
6. Set the 8.0" diameter optical flat between the offset centerline and scale with the top of the mirror just above the $Z_{\text{theodolite}}$ position from table 4.
7. The theodolite and autocollimator are next set parallel to one another. To do this first autocollimate the theodolite to the optical flat using the autocollimator kit in place of the eyepiece. When autocollimated to within an arc second, adjust the laser autocollimator orientation with the upper right and lower left adjustment screws on the New Focus mount. Readings can be made by either the digital readout or by an oscilloscope connected to the analog output port on the controller for the laser autocollimator. Each instrument must be autocollimated to within 1 arc sec (5 microradians).
8. Measure the separation between the theodolite scope and the autocollimator scope and record this value. Level the theodolite 180degrees, making sure to encompass the travel the theodolite must move. Calculate the z-height per page 8 and set the crosshairs in the theodolite to the appropriate mark on the scale.
9. Rotate towards the monument IAM3 which establishes the offset centerline and align to the monument. Adjust for monument calibration if necessary.
10. When aligned to the monument, zero out the horizontal angle and adjust the telescope body to zero the vertical angle. Rotate in yaw and pitch per table 4. The theodolite/autocollimator is now in its final position for positioning the optic.
11. Place the scale on the fixture. With the scale in its upper locked position, the center of the optic should correspond to 6.00" on the scale. Measure off the Z separation (theodolite centerline to autocollimator centerline) on the scale and move the LOS until the theodolite crosshairs are aligned to this position vertically.
12. Remove the scale and replace with the prism. Measure the distance to the prism adding the predetermined offset to the optic face dimension to the measurement per fig.6.
13. Place the theodolite/autocollimator over IAM32 and repeat steps 4 thru 10 above. The autocollimator should be in its final position for angular alignment per Table 4. Place the autocollimator in

5.4. ALIGNMENT OF FM_y , ITM_y , FM_x , AND ITM_x

1. Measure the separation from the FM optic face to the prism mount location on the alignment fixture Ligo D980001 and record this distance. Install the scale and verify that a mark on the scale corresponds to the center of the optic and record this value.
2. Locate and verify the position of IAM-29 located on the optical lever stand under adapter WA-1B.
3. Place the LOS with the FM_y optic suspended onto the optics table in WBSC-8 in its approximate location per fig.6.
4. Mount the Brunson Transit square to the Brunson 230-HC stand and place over IAM 28 at the theodolite height for FM_y (table 4).
5. Level the transit square with the coincidence level per appendix 2. Rotate the scope towards IAM12. Adjust the optical micrometer on the Brunson square by $-.077''$ per LIGO-T990017 (7), and sight the string and plumb bob over IAM12. The transit square is now in its final position and should not be moved again.
6. Assemble the Brunson 810 stand onto the optical lever bridge. Place the theodolite/autocollimator on the stand and level the stand with a machinist level and the theodolite with the bubble level. Using the optical plummet, center the theodolite over IAM-29 plus $.7071(A)$ per fig 6.
7. Clamp a 300mm or greater scale to the flange protector on WGV-6, aligning it to the scribe on the side of the valve.
8. Measure the separation between the theodolite scope and the autocollimator scope and record this value. Level the theodolite 180degrees, making sure to encompass the travel the theodolite must move. Calculate the z-height per page 8 and set the crosshairs in the theodolite to the appropriate mark on the scale.
9. Verify the squareness of the transit square with the LDS1000 laser autocollimator per appendix 3.
10. Set the 8.0'' diameter optical flat between the offset centerline and scale with the top of the mirror just above the $Z_{\text{theodolite}}$ position from table 4.
11. The theodolite and autocollimator are next set parallel to one another. To do this first autocollimate the theodolite to the optical flat using the autocollimator kit in place of the eyepiece. When autocollimated to within an arc second, adjust the laser autocollimator orientation with the upper right and lower left adjustment screws on the New Focus mount. Readings can be made by either the digital readout or by an oscilloscope connected to the analog output port on the controller for the laser autocollimator. Each instrument must be autocollimated to within 1 arc sec (5 microradians).
12. Check the separation between the theodolite scope and the autocollimator scope and record this value. Check that the theodolite is level 180 degrees, making sure to encompass the travel the theodolite must move. Recalculate, if necessary, the z-height per page 8 and set the crosshairs in the theodolite to the appropriate mark on the scale.
13. Rotate the theodolite/autocollimator towards the brunson square, and autocollimate off the mirror on the square. Zero out the horizontal angle. Rotate the theodolite in pitch and yaw per table 4. The

theodolite/autocollimator is now in its final position for positioning the optic and should not be moved again.

14. Place the scale on the fixture. With the scale in its upper locked position, the center of the optic should correspond to 6.00" on the scale or other value measured earlier. Measure off the Z separation (theodolite centerline to autocollimator centerline) on the scale and move the LOS until the theodolite crosshairs are aligned vertically.

15. Remove the scale and replace with the prism. Measure the distance to the prism adding the predetermined offset to the optic face dimension to the measurement see fig 6.

16. Place the theodolite/autocollimator over IAM29A and repeat steps 6 thru 13 above. If the Brunson square has not been moved, step 9 can be omitted. The autocollimator should be in its final position for angular alignment per Table 4. Place the autocollimator in analog mode and put 2 oscilloscopes in parallel. One should be placed near the autocollimator and the other placed in sight of the person adjusting the alignment fixture.

17. There will probably be multiple reflections off the optic. Distinguish between the reflection off the HR surface and the AR surface as it comes off the folding mirror and hits the optical flat. Locate the reflection off the HR surface and guide the reflection through the tube back toward the autocollimator. Adjust manually until a reading is made within 20 microradians. Fine adjustment can now be made by moving the permanent magnets to within 5-10 microradians.

18. Once the optic is in its final position, turn on the laser for the optical lever and steer the beam onto the photodetector until it is nulled out. Calibrate the optical lever per Calibration of Optical Levers, LIGO-T990026 (9).

19. Alignment of the ITM_y is similar to FM_y with the exception that the prism is in line with the optic and no angular compensation is required. Autocollimation occurs directly off the face of the optic.

20. Alignment of the FM_x and ITM_x is identical to the procedure above using the positions and angles found in table 4.

LIGO-DRAFT

FIG. 7 OPTIC LAYOUT BSC8

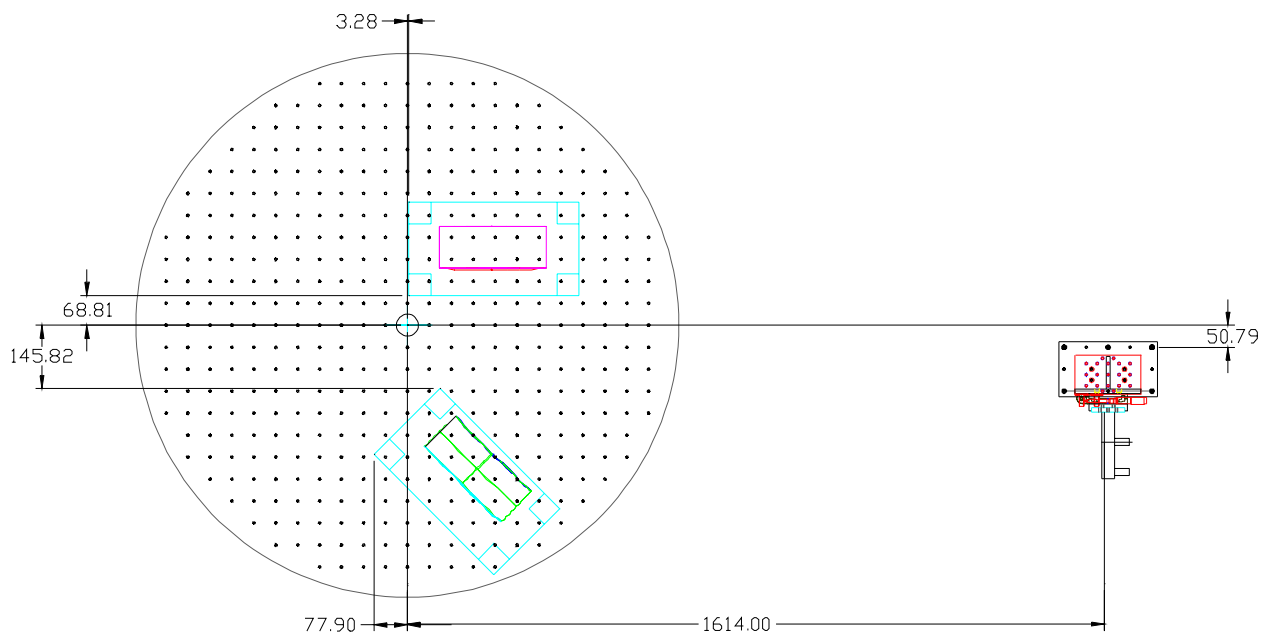
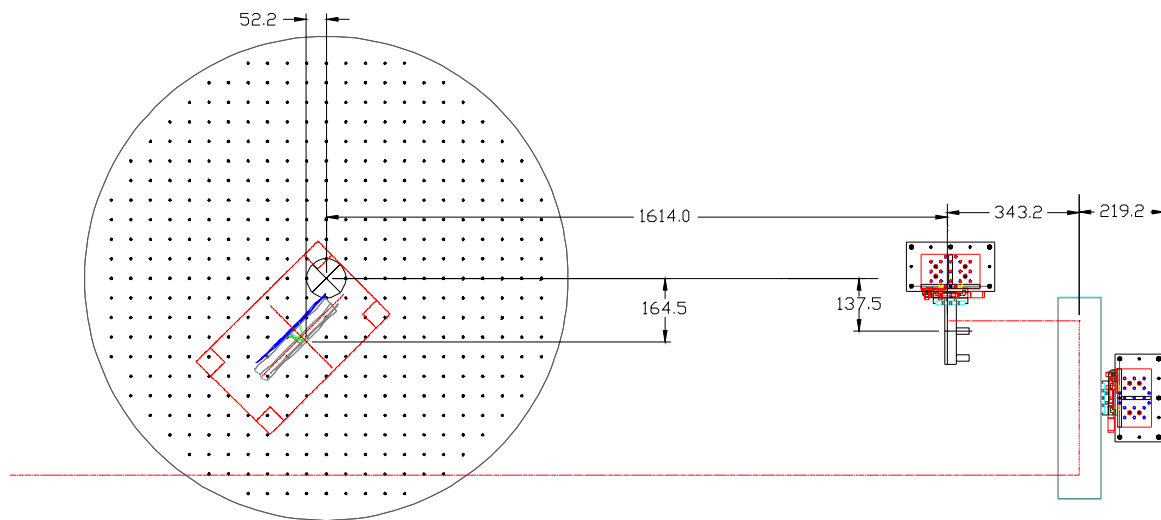

FIG. 8 OPTIC LAYOUT BSC4



LIC

5.5. ALIGNMENT OF END TEST MASSES ETM_Y AND ETM_X

1. Prepare vacuum equipment. Place a clean room over WBSC-6. Remove the door on WBSC-6 and adapter WA-14A to allow loading of the LOS and a line of sight for alignment equipment.
2. Measure the separation from the FM optic face to the prism mount location on the alignment fixture Ligo D980001 (8) and record this distance. Install the scale and verify that a mark on the scale corresponds to the center of the optic and record this value.
3. Place the PLX retroreflector into adapter WA-7A1 and the LOS with the ETM_Y optic suspended in WBSC-6 in their approximate location as shown in fig.9.
4. Mount the Brunson Transit square to the Brunson 230-HC stand and place over IAM 20 at the theodolite height for ETM_Y (table 4).
5. Level the transit square with the coincidence level per appendix 2. Rotate the scope towards IAM19. Sight the string and plumb bob over IAM19. The transit square is now in its final position and should not be moved again.
6. Assemble the Brunson 810 stand onto the alignment bridge. Place the theodolite/autocollimator on the stand and level the stand with a machinist level and the theodolite with the bubble level. Using the optical plummet, center the theodolite over IAM-21A (400mm toward IAM-20 from IAM21) and set the height as specified in table 4.
7. Clamp a 300mm or greater scale to the flange protector on WGV-6, aligning it to the scribe on the side of the valve.
8. Measure the separation between the theodolite scope and the autocollimator scope and record this value. Level the theodolite 180 degrees, making sure to encompass the travel the theodolite must move. Calculate the z-height per page 8 and set the crosshairs in the theodolite to the appropriate mark on the scale.
9. Verify the squareness of the transit square with the LDS1000 laser autocollimator per appendix 3.
10. Set the 8.0" diameter optical flat between the offset centerline and scale with the top of the mirror just above the $Z_{\text{theodolite}}$ position from table 4.
11. The theodolite and autocollimator are next set parallel to one another. To do this first autocollimate the theodolite to the optical flat using the autocollimator kit in place of the eyepiece. When autocollimated to within an arc second, adjust the laser autocollimator orientation with the upper right and lower left adjustment screws on the New Focus mount. Readings can be made by either the digital readout or by an oscilloscope connected to the analog output port on the controller for the laser autocollimator. Each instrument must be autocollimated to within 1 arc sec (5 microradians).
12. Check the separation between the theodolite scope and the autocollimator scope and record this value. Check that the theodolite is level 180 degrees, making sure to encompass the travel the theodolite must move. Recalculate, if necessary, the z-height per page 8 and set the crosshairs in the theodolite to the appropriate mark on the scale.

13. Rotate the theodolite/autocollimator towards the brunson square, and autocollimate off the mirror on the square. Zero out the horizontal angle. Rotate the theodolite in pitch and yaw per table 4. The theodolite/autocollimator is now in its final position and should not be moved again.

14. Place the scale on the fixture. With the scale in its upper locked position, the center of the optic should correspond to 6.00" on the scale or other value measured earlier. Measure off the Z separation (theodolite centerline to autocollimator centerline) on the scale and move the LOS until the theodolite crosshairs are aligned to this position and the edge of the scale.

15. Remove the scale and replace with the prism. Measure the distance to the prism adding the predetermined offset to the optic face dimension to the measurement. In the case of the Fold Mirror a calculation will have to be made to account for the spacing being at 45 degrees. To convert to Ligo Global coordinates subtract the value obtained from the y position of the theodolite (-38154 mm). Adjust the LOS until the correct y position is obtained per table 4.

16. Move the Brunson 810 stand approximately over IAM21. level the stand with a machinist level and the theodolite with the bubble level. Using the optical plummet, center the theodolite over IAM-21 and set the height as specified in table 4

17. Remove the prism to begin autocollimation of the optic hr surface with the laser autocollimator. Make sure the readings on the theodolite are per table 4. Place the autocollimator in analog mode and put 2 oscilloscopes in parallel. One should be placed near the autocollimator and the other placed in sight of the person adjusting the alignment fixture.

18. There will probably be multiple reflections off the optic. Distinguish between the reflection off the HR surface and the AR surface as it comes off the beamspitter. Locate the reflection off the HR surface and guide the reflection through the retroreflector and back to the autocollimator. Adjust manually until a reading is made within 20 microradians. Fine adjustment can now be made by moving the permanent magnets to within 5-10 microradians.

19. Once the optic is in its final position, turn on the laser for the optical lever and steer the beam onto the photodetector until it is nulled out. Calibrate the optical lever per Calibration of Optical Levers, LIGO-T990026 (9).

19. Alignment of the other ETM's are similar using the positions found in table 4.

20. The door and adapter are replaced and clean rooms removed.

LIGO-DRAFT

FIG.9 Y-MID STATION

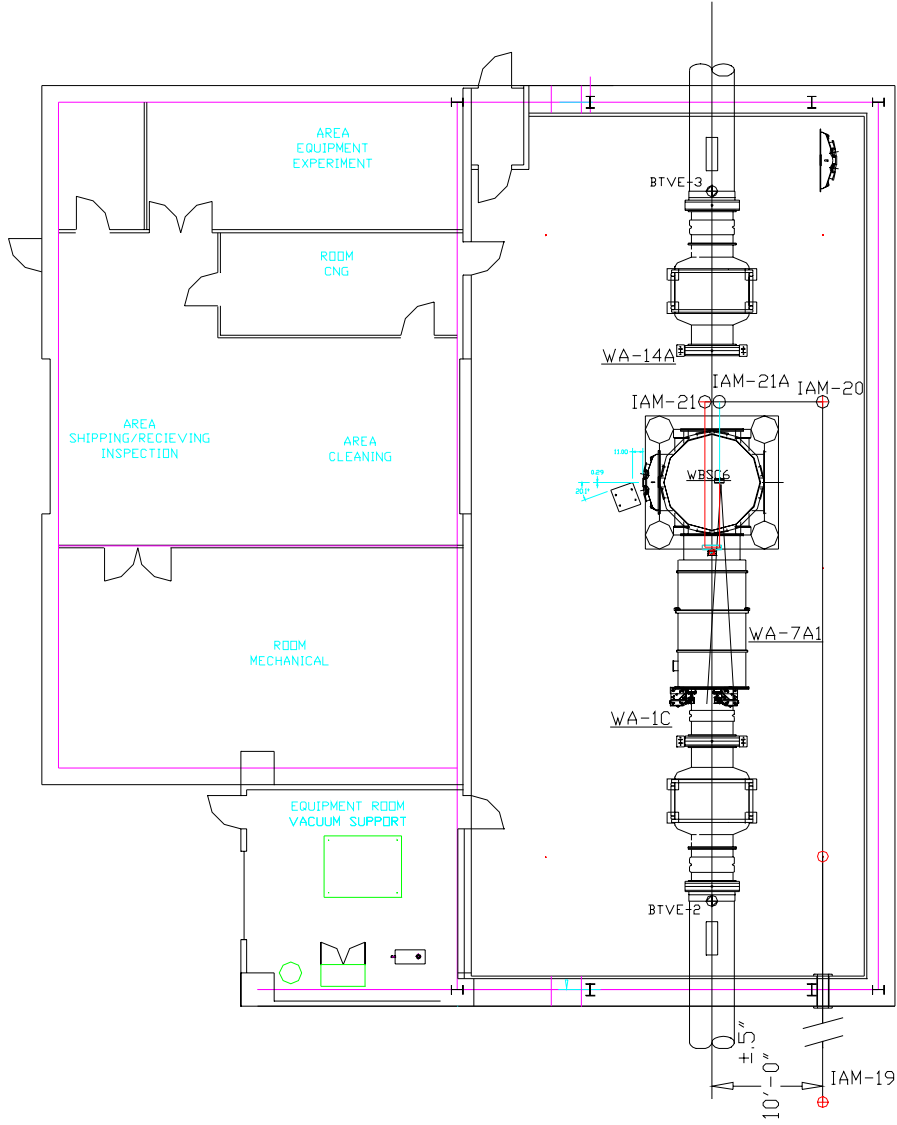

6 4K ALIGNMENT PROCEDURES (LIVINGSTON)

6.1. ALIGNMENT OF MMT3, RM, OF_{bs}, AND ITM_x

1. Prepare vacuum equipment. Place a clean room over spool piece B-1A along the x-axis arm and remove spool piece B-1A.
2. Locate monument 201 along the x-axis offset centerline a distance of 11600 mm from the vertex. Buck in with the Sokkia theodolite over this point using existing markers on the x-arm wall and at the vertex. Focus on the monument on the x-axis wall, level, and zero the horizontal rotation axis.
3. Establish a line at $x=11600$ mm by rotating the theodolite 90deg 0'0" and marking two points on the floor. Scribe monuments at (11600, -8.7), (11600, 214.1), and (11600,199.5). Mark these monuments and record.
4. Clamp a 300 mm or greater scale on a visible flange, and align it to the side of the flange pointing up.
5. Mount the Brunson Transit square to the Brunson 230-HC stand and place over IAM-L21 at the autocollimator height for MMT3 per table 1.
6. Level the transit square with the coincidence level per appendix 2. Rotate the scope towards the monument on the wall towards the beam tube. The transit square is now in its final position and should not be moved gain. Verify the height has not changed.
7. Set up for alignment of MMT3. Assemble the Brunson 810 stand onto the alignment bridge. Place the theodolite/autocollimator on the stand and level the stand with a machinist level and the theodolite with the bubble level. Using the optical plummet, roughly center the theodolite over the appropriate monument and roughly set the height per table 5.
8. Set the 8.0" diameter optical flat between the offset centerline and scale with the top of the mirror just above the Z-theodolite position.
9. The theodolite and autocollimator are next set parallel to one another. To do this first autocollimate the theodolite to the optical flat using the autocollimator kit in place of the eyepiece. When autocollimated to within an arc second(5 microradians), adjust the laser autocollimator orientation with the upper right and lower left adjustment screws on the New Focus mount. Readings can be made by either the digital readout or by an oscilloscope connected to the analog output port on the controller for the laser autocollimator. Each instrument must be autocollimated to within 1 arc sec(5 microradians).
10. Measure the separation between the theodolite scope and the autocollimator scope and record this value. Level the theodolite 180 degrees, making sure to encompass the travel the theodolite must move. Calculate the z-height by subtracting from the height the difference between the actual and design height of the marker and subtracting the separation distance measured from the theodolite height. Set the crosshairs in the theodolite to the appropriate mark on the scale.
11. Verify the squareness of the transit square with the LDS1000 laser autocollimator per appendix 3.

12. Rotate the theodolite/autocollimator towards the Brunson square, and autocollimate off the mirror on the square. Zero out the horizontal angle. Rotate the theodolite in pitch and yaw per table 5. The theodolite/autocollimator is now in its final position.
13. If the optic has not been placed in the chamber. Install the LOS per LIGO E000062-C titled LOS Installation Procedures For BSC Chambers. Have someone place a light on the scribe located on the top of the LOS structure. Rotate the theodolite in pitch until the scribe is located. Move the LOS structure until the crosshairs are aligned to the scribe.
14. Place the prism into the prism holder on the LOS fixture. Measure the distance to the prism adding the predetermined offset to the optic face dimension to the measurement. Move the LOS axially until the theodolite reads the correct axial distance per table 5.
15. Remove the prism to begin autocollimation of the optic hr surface with the laser autocollimator. Make sure the readings on the theodolite are per table 5. Place the autocollimator in analog mode and put 2 oscilloscopes in parallel. One should be placed near the autocollimator and the other placed in sight of the person adjusting the alignment fixture.
16. There will probably be multiple reflections off the optic. Distinguish between the reflection off the HR surface and the AR surface as it comes off the beamsplitter. Locate the reflection off the AR surface and guide the reflection through the retroreflector and back to the autocollimator. Adjust manually until a reading is made within 20 microradians. Fine adjustment can now be made by moving the permanent magnets to within 5-10 microradians.
17. Setup for Alignment of the recycling mirror. Raise or lower the Brunson transit square per table 5 and realign it to the offset centerline. Level the transit square.
18. Move the theodolite to the monument created for the RM and repeat steps 7 thru 16 above.
19. With the theodolite in the position and orientation for the recycling mirror, place an optical flat in the adapter between BSC-2 and HAM-3 per table 5. Adjust micrometers until autocollimated to within 5-10 microradians.
20. Setup for Alignment of the ITMx. Raise or lower the Brunson transit square per table 5 and realign it to the offset centerline. Level the transit square.
21. Move the theodolite to the monument created for the ITMx and repeat steps 7 thru 16 above

LIGO-DRAFT

6.2. ALIGNMENT OF BS AND ITM_Y

1. Prepare vacuum equipment. Place a clean room over spool piece B-1B along the y-axis arm and remove spool piece B-1B.
2. Locate monument along the y-axis offset centerline a distance of 11600 mm from the vertex. Buck in with the Sokkia theodolite over this point using existing markers on the y-arm wall and at the vertex. Focus on the monument on the y-axis wall, level, and zero the horizontal rotation axis.
3. Establish a line at $x=11600$ mm by rotating the theodolite $-90\text{deg } 0'0''$ and marking two points on the floor. Scribe monuments at $(11600, -199.5)$, and $(11600, -)$. Mark these monuments and record.
4. Clamp a 300 mm or greater scale on a visible flange, and align it to the side of the flange pointing up.
5. Mount the Brunson Transit square to the Brunson 230-HC stand and place over the monument created earlier along the y-axis and at the autocollimator height for the beamsplitter per table 5.
6. Level the transit square with the coincidence level per appendix 2. Rotate the scope towards the monument on the wall towards the beam tube. The transit square is now in its final position and should not be moved again. Verify the height has not changed.
7. Set up for alignment of the beamsplitter. Assemble the Brunson 810 stand onto the alignment bridge. Place the theodolite/autocollimator on the stand and level the stand with a machinist level and the theodolite with the bubble level. Using the optical plummet, roughly center the theodolite over the appropriate monument and roughly set the height per table 5.
8. Set the 8.0" diameter optical flat between the offset centerline and scale with the top of the mirror just above the Z-theodolite position.
9. The theodolite and autocollimator are next set parallel to one another. To do this first autocollimate the theodolite to the optical flat using the autocollimator kit in place of the eyepiece. When autocollimated to within an arc second (5 microradians), adjust the laser autocollimator orientation with the upper right and lower left adjustment screws on the New Focus mount. Readings can be made by either the digital readout or by an oscilloscope connected to the analog output port on the controller for the laser autocollimator. Each instrument must be autocollimated to within 1 arc sec (5 microradians).
10. Measure the separation between the theodolite scope and the autocollimator scope and record this value. Level the theodolite 180 degrees, making sure to encompass the travel the theodolite must move. Calculate the z-height by subtracting from the height the difference between the actual and design height of the marker and subtracting the separation distance measured from the theodolite height. Set the crosshairs in the theodolite to the appropriate mark on the scale.
11. Verify the squareness of the transit square with the LDS1000 laser autocollimator per appendix 3.
12. Rotate the theodolite/autocollimator towards the Brunson square, and autocollimate off the mirror on the square. Zero out the horizontal angle. Rotate the theodolite in pitch and yaw per table 5. The theodolite/autocollimator is now in its final position.

13. If the optic has not been placed in the chamber. Install the LOS per LIGO E000062-C titled LOS Installation Procedures For BSC Chambers. Have someone place a light on the scribe located on the top of the LOS structure. Rotate the theodolite in pitch until the scribe is located. Move the LOS structure until the crosshairs are aligned to the scribe.

14. Place the prism into the prism holder on the LOS fixture. Measure the distance to the prism adding the predetermined offset to the optic face dimension to the measurement. Use fig 6 for method of calculation. Move the LOS axially until the theodolite reads the correct axial distance per table 5.

15. Remove the prism to begin autocollimation of the optic hr surface with the laser autocollimator. Make sure the readings on the theodolite are per table 5. Place the autocollimator in analog mode and put 2 oscilloscopes in parallel. One should be placed near the autocollimator and the other placed in sight of the person adjusting the alignment fixture.

16. There will probably be multiple reflections off the optic. Distinguish between the reflection off the HR surface and the AR surface as it comes off the beamsplitter. Adjust the beamsplitter until the reflected beam hits the RM HR surface, reflecting back to the beamsplitter and to the autocollimator. Fine adjustment can now be made by moving the permanent magnets to within 5-10 microradians.

17. Setup for Alignment of ITMy. Raise or lower the Brunson transit square per table 5 and realign it to the offset centerline. Level the transit square.

18. Move the theodolite to the monument created for the ITMy and repeat steps 7 thru 16.

6.3. ALIGNMENT OF END TEST MASSES ETM_x AND ETM_y

1. Prepare vacuum equipment. Place a clean room over LBSC-4 and spool. Remove the door on LBSC-4 and spool piece to allow loading of the LOS and a line of sight for alignment equipment.

2. Measure the separation from the ETM optic face to the prism mount location on the alignment fixture Ligo D980001 (8) and record this distance.
3. Locate monument IAM-L20 on the offset centerline at (3993700,-1854.2). To do this buck in with the Brunson transit between two targets located high on the walls. Scribe a line along the offset centerline in the vicinity of the PSI brass tag located behind the rear door of LBSC-4. Now place a 1.5 meter straight edge over the brass tag mark toward the scribe line and square it off with a precise square. Mark this monument IAM-L21. The coordinates of this monument will be (4002365,-1854.2)
4. Roughly measure from IAM-L21 6025 mm towards the beam tube. Again using the Brunson transit scribe a line along the offset centerline in this area. Remeasure 6025 mm from IAM-L21 along the scribe and mark this monument IAM-L20.
5. With the 1.5 meter straight edge and precise square, place a scribe and monument at coordinates (3993700, 199.5) and mark this IAM-L22.
6. Measure the height of the scribe located on the side of the gate valve relative to BTVE-4 and record this value.
7. Clamp a 300 mm or greater scale to the flange protector on the gate valve, aligning it to the scribe on the side of the valve pointing up.
8. Mount the Brunson Transit square to the Brunson 230-HC stand and place over IAM-L21 at the autocollimator height for ETM_y per table 1. (200.3 mm for AR, -104.6 mm for HR).
9. Level the transit square with the coincidence level per appendix 2. Rotate the scope towards the monument on the wall towards the beam tube. The transit square is now in its final position and should not be moved again. Verify the height has not changed.
10. Assemble the Brunson 810 stand onto the alignment bridge. Place the theodolite/autocollimator on the stand and level the stand with a machinist level and the theodolite with the bubble level. Using the optical plummet, roughly center the theodolite over IAM-L22 and roughly set the height per table
11. Set the 8.0" diameter optical flat between the offset centerline and scale with the top of the mirror just above the Z-theodolite position.
12. The theodolite and autocollimator are next set parallel to one another. To do this first autocollimate the theodolite to the optical flat using the autocollimator kit in place of the eyepiece. When autocollimated to within an arc second (5 microradians), adjust the laser autocollimator orientation with the upper right and lower left adjustment screws on the New Focus mount. Readings can be made by either the digital readout or by an oscilloscope connected to the analog output port on the controller for the laser autocollimator. Each instrument must be autocollimated to within 1 arc sec (5 microradians).
13. Measure the separation between the theodolite scope and the autocollimator scope and record this value. Level the theodolite 180 degrees, making sure to encompass the travel the theodolite must move. Calculate the z-height by subtracting from the height the difference between the actual and design height of the marker and subtracting the separation distance measured from the theodolite height. Set the crosshairs in the theodolite to the appropriate mark on the scale.
14. Verify the squareness of the transit square with the LDS1000 laser autocollimator per appendix 3.

15. Rotate the theodolite/autocollimator towards the Brunson square, and autocollimate off the mirror on the square. Zero out the horizontal angle. Rotate the theodolite in pitch and yaw per table 1. The theodolite/autocollimator is now in its final position.

16. If the optic has not been placed in the chamber. Install the LOS per LIGO E000062-C titled LOS Installation Procedures For BSC Chambers. Have someone place a light on the scribe located on the top of the LOS structure. Rotate the theodolite in pitch until the scribe is located. Move the LOS structure until the crosshairs are aligned to the scribe.

17. Place the prism into the prism holder on the LOS fixture. Measure the distance to the prism adding the predetermined offset to the optic face dimension to the measurement. Move the LOS axially until the theodolite reads the correct axial distance per table 1.

18. Remove the prism to begin autocollimation of the optic hr surface with the laser autocollimator. Make sure the readings on the theodolite are per table 1. Place the autocollimator in analog mode and put 2 oscilloscopes in parallel. One should be placed near the autocollimator and the other placed in sight of the person adjusting the alignment fixture.

19. There will probably be multiple reflections off the optic. Distinguish between the reflection off the HR surface and the AR surface as it comes off the beamsplitter. Locate the reflection off the AR surface and guide the reflection through the retroreflector and back to the autocollimator. Adjust manually until a reading is made within 20 microradians. Fine adjustment can now be made by moving the permanent magnets to within 5-10 microradians.

20. At this point we must setup for alignment of the ETM telescope and ETM transmission monitor per LIGO T990088 titled COS IFO Alignment Procedures. This procedure will vary depending on which surface was used to align the optic.

A. If the HR surface was used for alignment per numbers found in Table 1, Place the 8.0" dia optic flat in front of the laser autocollimator while it is in its final position and autocollimate to the flat. Remove the theodolite and autocollimator by releasing the knob on the side of the Sokkia tribach. Replace the theodolite with the IR laser adapter and IR Laser autocollimator. Autocollimate to the optic flat with the IR autocollimator and remove the optic flat. Align the ETM telescope and ETM transmission monitor per LIGO T990088.

B. If the AR surface was used for alignment using numbers found in Table 1, the Brunson transit square and Sokkia theodolite/autocollimator must be reset to the heights used for aligning the HR surface. Follow steps above for aligning the transit square and theodolite at the values in Table 1 for ETMx(HR). Then place the 8.0" dia optic flat in front of the laser autocollimator while it is in its final position and autocollimate to the flat. Remove the theodolite and autocollimator by releasing the knob on the side of the Sokkia tribach. Replace the theodolite with the IR laser adapter and IR Laser autocollimator. Autocollimate to the optic flat with the IR autocollimator and remove the optic flat. Align the ETM telescope and ETM transmission monitor per LIGO T990088.

21. Once the optic is in its final position, turn on the laser for the optical lever and steer the beam onto the photodetector until it is nulled out. Calibrate the optical lever per Calibration of Optical Levers, LIGO-T990026 (9).

22. The door and adapter are replaced and clean rooms removed

APPENDIX 1 REFERENCES

- [1] LIGO-T970060- 00-D, Alignment Sensing/ Control Preliminary Design
- [2] Gary P. Wagner “Precision Survey of Beam Tube/ Vacuum Equipment Interface”, Rogers Surveying, October 1,1996.
- [3] LIGO-T970091-00, Determination of Core Optic Wedge Angles, Dennis Coyne
- [4] LIGO-D970210, ASC Monument Locations - Wa. Site, K.Mason
- [5] LIGO-D980499, ASC Monument Locations - La. Site, K.Mason
- [6] LIGO-T980044, Determination of Global and Ligo Coordinate axis for the Ligo Sites, Albert Lazzarini
- [7] LIGO-T990017, Calibration of Initial Alignment Survey by Sighting through Y1 Beam Tube, M.Zucker
- [8] LIGO-D980001, Alignment Fixture
- [3] LIGO-T990026, Calibration of Optical Levers, M.Zucker

APPENDIX 2 LEVELING PROCEDURE ON THE BRUNSON 75H TRANSIT SQUARE

1. Level scope by circular level.
2. Set scope such that 2 leveling screws are in line with scope and 2 screws are 90 deg. to scope.
3. Level scope eith tangent screw (brass knob inside transit casting).
4. Rotate 180 deg and take out half error with tangent screw and half with leveling screws until bubbles on coincidence level are in line with one another.
5. Rotate 90 deg and take out with leveling screws.
6. Rotate 180 deg from last position and take out half with tangent screws and half with leveling screws.

LIGO-DRAFT

7. If necessary continue this method of rotating 90 deg adjusting leveling screws, then 180 adjusting half and half until bubble is level over full 360 deg.
8. When close only use leveling screws and tighten only.
- 9 Rotate 360 deg to make sure transit is level.

APPENDIX 3 VERIFICATION AND REALIGNMENT OF INDICATING MIRROR ON THE BRUNSON 75H OPTICAL TRANSIT SQUARE

The Brunson optical transit square's side indicating mirror surface is nominally parallel to the square's optical axis and vertical (azimuthal) rotation axis within 1 arcsecond . However it has been observed to go out of square during shipping as well as between setups. It is therefore imperative to check and, if required, adjust the mirror for squareness each time it is mounted for use.

NOTE: Verification of square adjustment should take approximately 45 minutes for an experienced operator, assuming all equipment is staged and ready. Restoring alignment may take from 2 to 6 hours depending on the degree of misalignment. In what follows it is assumed that the user is familiar with and experienced in the use and maintenance of transit instruments.

1. Set the transit over the desired survey position at the required height, and level using the coincidence level according to procedure in Appendix II. Let the instrument settle and thermally equilibrate for at least 15 minutes and recheck the coincidence level in all directions before proceeding.
2. Verify that the plunge axis and azimuth axis are mutually orthogonal and orthogonal to the optic axis;

LIGO-DRAFT

A. Set the optical micrometer at zero and null the crosshair to a fixed target at least 20' away, preferably at about the same height as the transit. Be sure to lock the azimuth circle.

B. Plunge the transit to come up horizontal on the opposite side; have an assistant scribe a new reference target on a stable surface at least 20' away in the opposite direction, exactly coinciding with the crosshair position. Plunge again to double check that the two target marks and the transit lie on a common line. If there is some error, the transit can be translated slightly using fine horizontal adjustments of the mount (take out half the error by translation and finish with azimuth fine adjustment; iterate until the crosshair splits both marks when plunged).

C. Unlock the azimuth and slew the transit horizontally 180° to locate the second mark. Lock the coarse azimuth and use the fine adjust to split the mark with the crosshair.

D. Plunge the transit through 180 degrees and check that the crosshair once again again splits the first target. Measure any discernible error using the optical micrometer.

E. Recheck the instrument level. If not level, readjust level and start over.

If there a visible difference not attributable to a leveling error, work out its angular magnitude by dividing the micrometer value by the distance between the two temporary test targets. If the angle deviation exceeds 1 arcsecond (5 microradians) the transit square is in need of mechanical recalibration. This requires return to the factory and cannot be done in the field.

F. If the instrument is OK, remember to reset the horizontal position to the survey mark if you moved it for this test.

LIGO-DRAFT

3. Set the LAE-1000 laser autocollimator on a rigid fine-adjust mount at the same height as the transit axis. Turn on the autocollimator and adjust it to autocollimate on the transit square's side mirror.
4. Connect an XY oscilloscope to the LAE-1000 outputs and adjust the scale to represent approximately ± 50 microradians (± 10 arcseconds) full scale. Make certain that the display spot is at screen center with the X and Y inputs grounded. Place the LAE-1000 controller into "analog" mode and verify that the oscilloscope display registers the autocollimation spot. Adjust the autocollimator mount to null the display.
5. Gently release the plunge lock and slowly plunge the transit square through 360 degrees while monitoring the spot position on the oscilloscope. The spot will describe a roughly circular path on the screen, whose diameter indicates the angular runout between the mirror normal and the plunge axis.

NOTE: There is generally 10 microradians of hysteresis which presents an irreducible limit to the precision of squareness.

This may be due to bearing clearances in the transit (of order a micron excess clearance would do it). Plunging the transit in the opposite direction may reveal that the path of described by the autocollimator readout spot is different depending on the direction of rotation. It may also contain discrete jumps.

6. If the total runout seen on the autocollimator readout exceeds 15 microradians peak to peak, the mirror is in need of adjustment. This is a tricky procedure but it can be done in the field using the autocollimator. Proceed as follows:

- A. Be sure the transit azimuth and leveling screws have been firmly locked. Avoid touching the transit frame or telescope unnecessarily

LIGO-DRAFT

during this procedure; using one finger on the eyepiece or objective housing to plunge will help minimize thermal distortion.

B. Gently remove the friction-fit sheet metal cap covering the indicating mirror. This will reveal three small socket-head adjustment screws surrounding the mirror itself.

NOTE: The construction of the mirror mount differs from the cutaway diagram shown in the manual. Our unit has three spring-loaded kinematic adjustment screws on the mirror cell face, and does NOT have a wide spherical bearing with radial adjustments as shown in the documentation. DO NOT TOUCH any screws other than the small face adjustments.

C. Obtain three long-handled hex L-keys to fit the adjustment screws and insert their short legs into the sockets, handles pointing radially away from the axis. A balldriver or T-handled driver will not afford adequate sensitivity. Use a pencil or removable marker to label the screws A, B, and C (or something like that) on the cell face.

D. By plunging the transit clockwise and counterclockwise, attempt to determine the center of the autocollimator readout pattern. Adjust the autocollimator alignment so that the center of the oscilloscope screen corresponds to this pattern center (i.e., so that the spot orbits the origin at equal distance when you plunge through a full circle).

E. Rotate the transit so that a pair of the screws (say A and B) are oriented horizontally, and note the horizontal error on the autocollimator readout. If this happens to be a point where the horizontal error is very small, pick another pair of screws (say A and C).

F. Take out half of the error with each of the two adjustment

LIGO-DRAFT

screws.

NOTE: These screws are INCREDIBLY SENSITIVE. Use a light finger touch on the end of the hex key. Anticipate the "stiction" you will need to overcome before the screw begins to move, and back off the pressure as it starts to rotate. It may take considerable practice to get the feel of it; it may be necessary to reduce the sensitivity of the oscilloscope until you do.

G. Plunge 180 and 360 to verify that the error in the plane of the two chosen screws is zero, that the remaining error is mostly vertical, and that it is symmetrical about the origin.

H. Take out the remaining error with the third screw.

I. Repeat the evaluation. If the runout still exceeds 15 microradians, repeat steps D. through H. Four or five iterations is not unusual.

J. Remember to quit when it's good enough! Experience has shown it isn't worth trying to do much better than 15 microrad peak-peak. This implies the square can only be trusted to ± 1.5 arcsecond; specifications aside, this seems to be the best the instrument can do repeatably.

K. Remove the hex keys (gently!) and replace the sheet metal cover. Record the procedure and final runout figures from the autocollimator readout in the Initial Alignment log.

7. When the total runout is within limits, proceed with setting the transit for use. If feasible, check the runout with the autocollimator occasionally during use, especially after any disturbance or moving of the transit.

LIGO-DRAFT