

LASER INTERFEROMETER GRAVITATIONAL WAVE OBSERVATORY
- LIGO -
CALIFORNIA INSTITUTE OF TECHNOLOGY
MASSACHUSETTS INSTITUTE OF TECHNOLOGY

Technical Note	LIGO-T960113-00 - D	06/26/96
Modal Model Update 1 Interferometer Operators		
Daniel Sigg		

Distribution of this draft:

ASC

This is an internal working note
of the LIGO Project.

California Institute of Technology
LIGO Project - MS 51-33
Pasadena CA 91125
Phone (818) 395-2129
Fax (818) 304-9834
E-mail: info@ligo.caltech.edu

Massachusetts Institute of Technology
LIGO Project - MS 20B-145
Cambridge, MA 01239
Phone (617) 253-4824
Fax (617) 253-7014
E-mail: info@ligo.mit.edu

WWW: <http://www.ligo.caltech.edu/>

1 INTRODUCTION

This document describes the modal model representation of a LIGO-type interferometer consisting of two arm cavities and a recycled Michelson interferometer. It includes a list the necessary conventions for naming, signs, etc. Additionally, the resonance condition of a cavity and the dark port condition of a Michelson interferometer are discussed.

2 CONVENTIONS

2.1 NAMING

We are using two conventions for naming the optical components; they are either called by their name (abbreviation) or by their number. A list of these conventions is found in Table 1.

Table 1: Naming Convention

Name	Abbreviation	Type	No.
on-line arm		arm cavity	1
off-line arm		arm cavity	2
input test mass for the on-line arm	ITM	mirror	1
end test mass for the on-line arm	ETM	mirror	2
input test mass for the off-line arm	ITM	mirror	3
end test mass for the off-line arm	ETM	mirror	4
recycling mirror	RM	mirror	5
beam splitter	BS	mirror	6

2.2 COORDINATE SYSTEM

The z -axis of the coordinate system which is used for the modal model calculations is always pointing in the direction of the beam propagation. For the optical systems we are interested in the beam direction can always be oriented in the horizontal plane. The y -axis is the defined to be vertical and upward. This then makes the x -axis horizontal and perpendicular to beam propagation direction. Since the beam splitter mirrors the image in the horizontal direction, but not in the vertical direction, the coordinate system for the off-line arm is left-handed for the incident beam. After reflection at the ETM mirror, the coordinate systems becomes again right-handed. A summary of the axes orientation can be found in Table 2.

Table 2: Coordinate system orientations.

	incident	reflected
input laser beam	right-handed	left-handed
on-line arm	right-handed	left-handed
off-line arm	left-handed	right-handed
antisymmetric port	right-handed	

2.3 ANGLE ORIENTATION

Since we are concerned about angular misalignment, we have to define rotation vectors for the tilts of the mirrors. As usual, a positive misalignment angle corresponds to a right-handed rotation around the axis defined by the rotation vector (see Fig. 1).

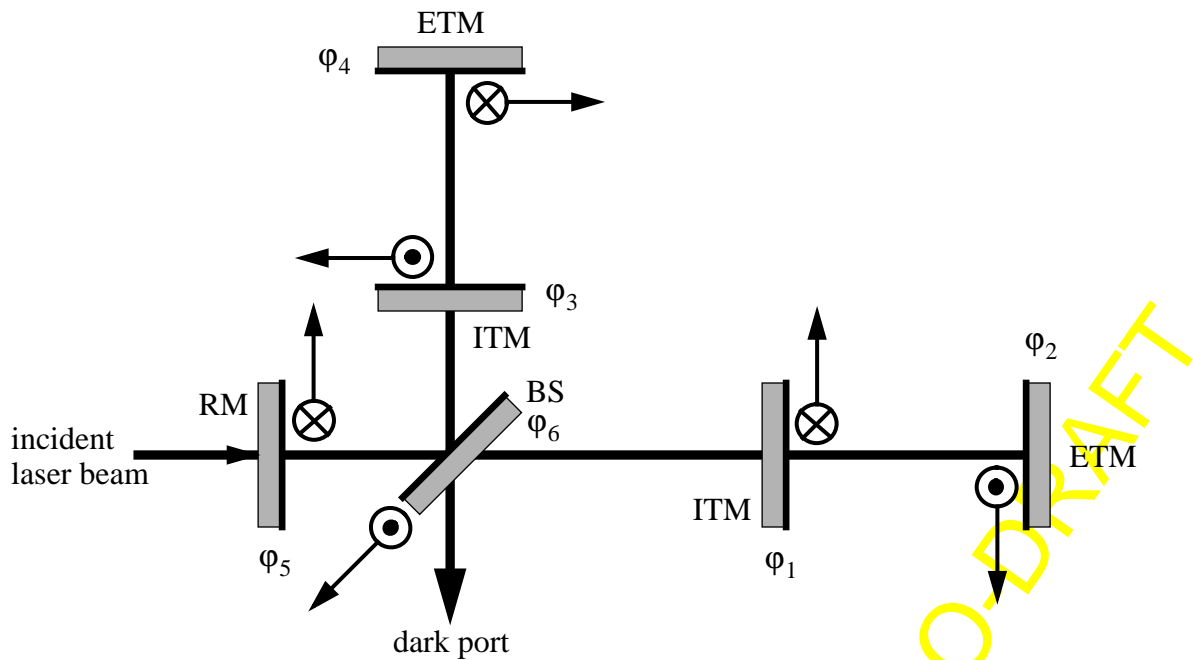

Figure 1: Sign convention of the misalignment angles.
Shown are the rotation axes (vectors) for both horizontal and vertical misalignments. The coated mirror surfaces are drawn with bold lines.

We are defining common (\overline{ETM} , \overline{ITM}) and differential (ΔETM , ΔITM) angles of the input and end test masses, respectively, as follows:

$$\begin{bmatrix} \Delta ETM \\ \Delta ITM \\ \overline{ETM} \\ \overline{ITM} \\ RM \\ BS \end{bmatrix} = \frac{1}{\sqrt{2}} \begin{bmatrix} 0 & -1 & 0 & 1 & 0 & 0 \\ -1 & 0 & 1 & 0 & 0 & 0 \\ 0 & 1 & 0 & 1 & 0 & 0 \\ 1 & 0 & 1 & 0 & 0 & 0 \\ 0 & 0 & 0 & 0 & \sqrt{2} & 0 \\ 0 & 0 & 0 & 0 & 0 & \sqrt{2} \end{bmatrix} \begin{bmatrix} \Phi_1 \\ \Phi_2 \\ \Phi_3 \\ \Phi_4 \\ \Phi_5 \\ \Phi_6 \end{bmatrix} \quad (1)$$

where the $\Phi_1 \dots \Phi_6$ are the angles of the individual mirrors. The matrix of Eqn. (1) is a true rotation matrix. Both the recycling and the beamsplitter angle are not affected by this rotation.

All angles are measured in units of the beam divergence angle in one of the arm cavities Φ_0 :

$$\Phi_0 = \frac{w_0}{z_0} \approx 9.63 \times 10^{-6} \text{ rad} \quad (2)$$

with w_0 and z_0 the beam waist size and the Rayleigh length, respectively.

2.4 AMPLITUDE REFLECTION COEFFICIENTS

We follow the convention that the amplitude reflection coefficients carry a negative sign, if the reflection happens from the coated mirror surface, and a positive sign, if the reflection happens from the substrate side (see Fig. 1).

2.5 RADIUS OF CURVATURES

Surfaces with curvatures where the center of tangent circle lies behind the incident beam have a negative numerical value. For a LIGO-type interferometer this means, in general, that the recycling mirror has a negative curvature, whereas the ETM mirrors have positive curvatures.

2.6 CAVITY AND MICHELSON LENGTHS

The lengths of the arm cavities are denoted by L_1 and L_2 , whereas the Michelson lengths are denoted l_1 and l_2 . It is convenient to define common and differential lengths, they are defined as follows:

$$\begin{aligned} L_D &= \frac{L_1 - L_2}{2} & \text{and} & & L_C &= \frac{L_1 + L_2}{2} \\ l_D &= \frac{l_1 - l_2}{2} & \text{and} & & l_C &= \frac{l_1 + l_2}{2} \end{aligned} \quad (3)$$

The differential Michelson length l_D is also called asymmetry. With the convention from Eqn. (3) a positive asymmetry makes the on-line Michelson length longer than the off-line one.

2.7 ANGULAR MISALIGNMENT OPERATORS

The modal space representation of the operators for propagation and misalignment are given in Ref. [1]. The only uncertainty comes from the fact that one has to specify when to use the mirror matrix M and when to use its Hermitian conjugate M^\dagger . We are using M when reflecting from the substrate surface and M^\dagger when reflecting from the coated surface. This is different from the convention in Ref. [1].

2.8 INPUT BEAM MISALIGNMENT OPERATOR

A misalignment of the input beam to a cavity can be understood as a tilt and shift of the incident laser beam relative to the eigenmode of the cavity. In the modal space representation a misaligned input beam can be calculated from a perfectly aligned beam by applying a rotation and a shift:

$$E_{inp} = M\left(\frac{\alpha}{2}, \frac{\beta}{2}\right) \otimes O(-\Delta x, -\Delta y) \otimes E_{inp}^{align} \quad (4)$$

where M and O are rotation and lateral shift operators as defined in ref. [1], α and β are the angles around the y - and x -axes between the input beam and the optical axis, respectively, and Δx and Δy are the lateral shifts of the input beam in the x and y direction. For small input beam misalignments the order in which the rotation and shift operator are applied doesn't matter. The signs of the input beam tilts are the same as for the recycling mirror angles, whereas the direction of the shift is determined by the coordinate system alone (see Fig. 1).

2.9 MODULATION AND DEMODULATION

The phase modulation of the incoming light is done with a cosine function only. The down-converted signal then carries a factor of $1/2$ from the demodulation with a cosine (I-phase) and sine (Q-phase). This means that the amplitude of the rf photocurrent induced by the light hitting the detector is a factor of 2 larger than one would expect from the photodetector efficiency alone.

2.10 CENTER OF BEAM OPERATOR

One can define the center point of a beam which is described by the field $E(x, y)$ as the center of gravity (CoG) of the field with the following equation:

$$\text{CoG}_x = \frac{\iint dx dy E^\dagger x E}{\iint dx dy E^\dagger E} \quad (5)$$

and similarly for the y -position by exchanging x and y in the above equation. Eqn. (5) can be written in the modal space representation as

$$\text{CoG}_x = \frac{1}{w(z)} \frac{E_{mn}^\dagger C_{mn,kl}^x E_{kl}}{E_{mn}^\dagger E_{mn}} \quad (6)$$

with
$$C_{mn,kl}^x = \frac{1}{\sqrt{8}} \langle mn | H_1(x) | kl \rangle = \frac{1}{\sqrt{2}} T_{mn,kl}^{10} \quad (7)$$

For a definition of $T_{mn,kl}^{10}$ see ref. [1].

3 MATRICES FOR INTERFEROMETERS

3.1 ARM CAVITIES

Following the derivation given in Ref. [1] we write the cavity equation for the reflected field of the on-line arm as:

$$E_{refl} = M_1(r_1 - r_2(r_1^2 + t_1^2))e^{-2ikL_1} M_1^\dagger P_{L_1} M_2^\dagger P_{L_1} (I - r_1 r_2 e^{-2ikL_1} M_1^\dagger P_{L_1} M_2^\dagger P_{L_1})^{-1} E_{in} \quad (8)$$

and for the transmitted field:

$$E_{trans} = t_1 t_2 e^{-ikL_1} P_{L_1} (I - r_1 r_2 e^{-2ikL_1} M_1^\dagger P_{L_1} M_2^\dagger P_{L_1})^{-1} E_{in} \quad (9)$$

The light inside the cavity is described by

$$E_{circ} = t_1 (I - r_1 r_2 e^{-2ikL_1} M_1^\dagger P_{L_1} M_2^\dagger P_{L_1})^{-1} E_{in} \quad (10)$$

The fields for the off-line cavity can be obtained from Eqns. (8), (9) and (10) by replacing L_2 with L_1 and by replacing the subindices 1 and 2 with 3 and 4, respectively.

3.2 RECYCLED MICHELSON INTERFEROMETER

To simplify the equations for the recycled Michelson interferometer, one can write the arm cavities as single operators G_1 and G_2 using the definition from Eqn. (8). By collapsing the two Michelson arms into one operator, the recycled Michelson interferometer acts like a normal cavity.

Defining the common Michelson operator M_C

$$M_C = t_6^2 e^{-2ikl_D} P_{+l_D} G_1(k) P_{+l_D} + r_6^2 e^{+2ikl_D} P_{-l_D} G_2(k) P_{-l_D} \quad (11)$$

the reflected field at the symmetric port becomes:

$$E_{symm} = M_5(r_5 + (r_5^2 + t_5^2))e^{-2ikl_C} M_5^\dagger P_{l_C} M_C P_{l_C} (I + r_5 e^{-2ikl_C} M_5^\dagger P_{l_C} M_C P_{l_C})^{-1} E_{in} \quad (12)$$

The field inside the recycling cavity (just after the recycling mirror) one obtains:

$$E_{RC} = t_5 (I + r_5 e^{-2ikl_C} M_5^\dagger P_{l_C} M_C P_{l_C})^{-1} E_{in} \quad (13)$$

If one defines the differential Michelson operator M_D as:

$$M_D = r_6 t_6 \left\{ e^{-2ikl_D} P_{+l_D} G_1(k) P_{+l_D} - e^{+2ikl_D} P_{-l_D} G_2(k) P_{-l_D} \right\} \quad (14)$$

the fields at the antisymmetric port becomes

$$E_{anti} = t_5 e^{-2ikl_C} P_{l_C} M_D P_{l_C} (I + r_5 e^{-2ikl_C} M_5^\dagger P_{l_C} M_C P_{l_C})^{-1} E_{in} \quad (15)$$

With this definition for the field at the antisymmetric port it doesn't really matter where the beam splitter is positioned relative to the recycling mirror; however, the field is always calculated at a distance equivalent to the one to the recycling mirror.

4 BEAMSPLITTER MATRIX

Up to now we assumed that the beamsplitter is always perfectly aligned. We now introduce the beamsplitter distortion matrix M_6 which rotates the beam splitter by an angle ϕ_6 . This rotation matrix affects the transmitted beam insignificantly (see Ref. [1] for a good argument), but the reflected beam is tilted by the same rotation matrix as the other mirrors.

The Michelson interferometer equations are easily modified by defining new operators for the common and the differential Michelson operators of eqns. (11) and (14):

$$P_{l_C} M_C P_{l_C} = t_6^2 e^{-2ikl_D} P_{l_1} G_1 P_{l_1} + r_6^2 e^{+2ikl_D} M_6^\dagger P_{l_2} G_2 P_{l_2} M_6^\dagger \quad (16)$$

$$\text{and } P_{l_C} M_D P_{l_C} = r_6 t_6 \left\{ e^{-2ikl_D} M_6 P_{l_1} G_1 P_{l_1} - e^{+2ikl_D} P_{l_2} G_2 P_{l_2} M_6^\dagger \right\} \quad (17)$$

5 RESONANCE CONDITION

The resonance condition of a cavity (both arm cavities and the recycling cavity) can be expressed as a condition on the round-trip operator M_{rt}

$$M_{rt} = e^{-2ikL} M_1^\dagger P_L M_2^\dagger P_L \quad (18)$$

When the phase of an eigenmode is an exactly multiple of 2π , the mode resonants. The resonance condition is usually different for each eigenmode, i.e. higher order modes are not resonant, when the fundamental mode is.

If a cavity must be resonant for a given eigenmode E and if we denote its eigenvalue for the round-trip operator M_{rt} by c , the length of the cavity has to be adjusted by a length ΔL , so that

$$-2k\Delta L + \arg(c) = 2\pi n \quad \text{with } n \in \mathbf{Z} \quad (19)$$

Similarly, a condition for an eigenmode to be anti-resonant can be written as

$$-2k \Delta L + \arg(c) = 2\pi \left(n + \frac{1}{2} \right) \quad \text{with } n \in \mathbf{Z} \quad (20)$$

6 DARK PORT CONDITION

The antisymmetric port of the Michelson interferometer in the LIGO configuration is usually the dark port, i.e. no carrier light is leaving the interferometer through this port and all power is reflected towards the recycling mirror. It is this condition which gives the recycling cavity a high finesse. Let E be the eigenmode of the resonant eigenmode of the recycling cavity, then the power at the antisymmetric port can be written as

$$P_{dark} = \frac{1}{2} E^\dagger_{anti} E_{anti} \propto E^\dagger P_{l_c}^\dagger M_D^\dagger M_D P_{l_c} E \quad (21)$$

The derivative can then be approximated by

$$\frac{d}{dl_D} P_{dark} \propto \sin(-4kl_D + \arg(\xi)) + \dots \quad (22)$$

$$\text{with } \xi = E^\dagger P_{l_2}^\dagger G_2^\dagger P_{l_2}^\dagger P_{l_1} G_1 P_{l_1} E \quad (23)$$

where we neglected the terms coming from the recycling cavity resonance built-up. (These terms are zero at the exact dark port condition, i.e. the dependence of the power in the recycling cavity on the differential Michelson length l_D is second order only.) The dark port condition can then be formulated as

$$-4kl_D + \arg(\xi) = 2\pi n \quad \text{with } n \in \mathbf{Z} \quad (24)$$

If both the resonance condition of the recycling cavity and the dark port condition of the Michelson have to be adjusted, it has to be done iteratively. First, the resonant is set and the resonant eigenmode is used to calculate the differential Michelson length correction for the dark port condition. This will slightly change the resonant mode, so the resonance condition has to be applied again. These steps have to be repeated, until both the common and the differential Michelson lengths have converged.

REFERENCE

- [1] Y. Hefetz, N. Mavalvala and D. Sigg, ‘‘Principles of Calculating Alignment Signals in Complex Optical Interferometers’’, LIGO-P960024-00-D (1996).