

**New Folder Name** wavefront Distortion

---

# Wavefront Distortion in Laser-Interferometric Gravitational-Wave Detectors

B. J. Meers and K. A. Strain  
Department of Physics and Astronomy,  
University of Glasgow,  
Glasgow G12 8QQ,  
Scotland.

December 5, 1990

## Abstract

We discuss the limitations placed upon the sensitivity of laser-interferometric gravitational-wave detectors by imperfections in the shape or alignment of the optics, for various different detector configurations. Wavefront distortion is seen to be a serious problem for interferometers which recycle only the light power. We suggest that the use of dual recycling can confer greater tolerance of distortion, and therefore better gravitational-wave sensitivity, upon an interferometer. This suggestion is backed up with results from an experimental implementation of dual recycling. However, in its simple form, dual recycling only helps significantly when the signal bandwidth is narrowed. We propose a new optical arrangement, dual recycling with a compound mirror, which gives greater tolerance of distortion without restricting the bandwidth. This may improve the sensitivity of future gravitational-wave detectors by a factor as high as 5, while at the same time improving their operational flexibility.

## 1 Introduction

There are several current proposals for the construction of large laser interferometers for the observation of gravitational waves [1, 2, 3, 4]. Possible sources include such exotic objects as supernovae, coalescing neutron stars or black holes, pulsars or even the early stages of the big bang; see Thorne [5] for a recent review. While these sources are extremely energetic, the gravitational radiation has only a weak effect upon terrestrial objects, so very sensitive detectors are required.

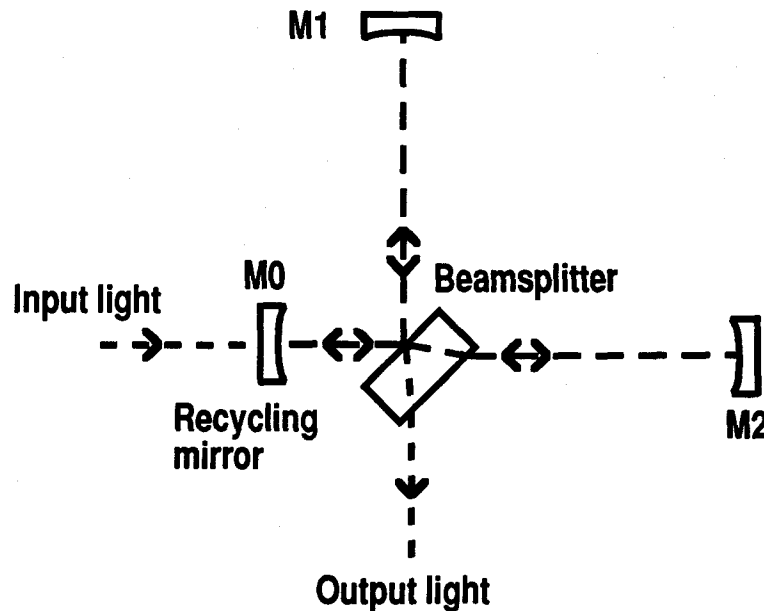

Figure 1: *The optical arrangement of an interferometer using power recycling. Differential phase shifts change the power of the output light. With the interferometer on a dark fringe, most of the light is directed back towards the laser, is caught by mirror  $M_0$  and added coherently to the incoming laser light.*

If a gravitational wave distorts a region of spacetime, any light passing through this region will experience a change in travel time, or phase. This may be converted to a change in intensity by interference with light of a different history, as indicated in figure 1. If this power change at the output of the interferometer is to be detectable, it must be larger than the statistical fluctuations which, at least for unsqueezed vacuum, may be regarded as being due to the finite number of photons observed in the period of measurement. The significance of this photon counting error (or shot noise) is, therefore, reduced if the power level of the light is high. This led Drever [6] to suggest that, with the interferometer operating on a dark fringe, the light effectively reflected back from the interferometer might be recycled so as to increase the circulating power. This is achieved by adding a suitably chosen and controlled mirror, as shown in figure 1. In addition, the output power change, hence the possible gravitational-wave sensitivity, may be enhanced even further for continuous signals by ensuring that at least one of the sidebands induced on the light by the gravitational wave is perfectly resonant within the optical system. The original version of this idea of resonant recycling [6] used a rather different optical arrangement. Recently, a more flexible variant using

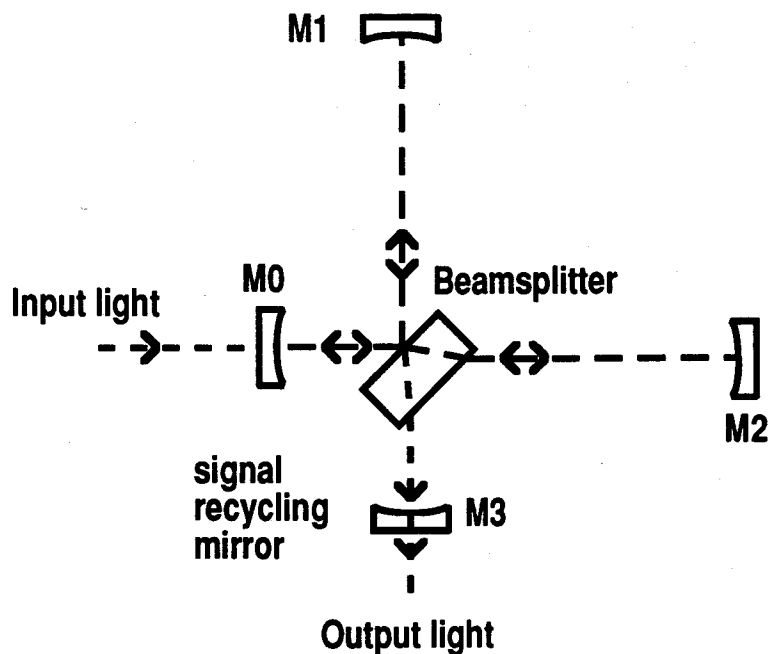

Figure 2: *The optical arrangement for dual recycling. The partially transmitting signal recycling mirror  $M_3$  is placed at the output to resonate signal sidebands induced by a gravitational wave.*

the same basic optical layout of figure 1 has been suggested: *dual recycling* [7] adds a mirror at the output port of the interferometer, positioned so that a gravitational-wave induced sideband is resonant. The optical arrangement is indicated in figure 2. The transmission of the signal recycling mirror  $M_3$  determines the signal storage time and therefore the sensitivity-bandwidth combination of the detector [7, 8]. If recycling systems are to best improve the sensitivity of interferometric gravitational-wave detectors, the optical losses within the interferometer must be very low. Not only must the absorption and scattering at the mirrors be small, but little light can be allowed to leak out due to imperfect interference at the beamsplitter. In this paper we will discuss the significance of poor interference resulting from distortion of the interfering beams and evaluate the requirements that this places upon the quality of the optical components. Much of the discussion will be concerned with the less obvious case of dual recycling, in both broadband and narrowband modes. We will describe an experiment that we have performed that tests our conclusions. We will also suggest a variant of dual recycling that greatly eases the requirements on mirror figure and alignment. This may allow significantly better gravitational-wave sensitivity.

## 2 Distortion in power recycling

If there is imperfect interference between the beams from the two arms of the interferometer, light that would have been directed back towards the laser and recycled will instead leak out towards the photodetector. This has two undesirable consequences: the loss reduces the power buildup; and the extra light hitting the photodiode will increase the level of photon noise. The signal is reduced and the noise is increased.

In order to calculate the reduction in signal to noise ratio produced by poor fringe contrast, consider an interferometer such as that one shown in figure 1. The action of the gravitational wave may be regarded as being a phase modulation of the circulating light, imposing sidebands that exit the interferometer at the beamsplitter. These sidebands are then detected by beating them with some reference beam. This reference beam, or local oscillator, is usually derived from within the interferometer, either by differential phase modulation of the interfering beams (internal modulation) or by splitting off a small fraction of the circulating light, which can then be modulated (external modulation [9, 2, 10]). The latter system avoids problems with losses and distortions associated with modulators, so is the system that we will explicitly consider here (see also section 3.4). Let us assume that a fraction  $\epsilon$  of the power is taken out by reflection off a surface (such as the back face of the beamsplitter) in one arm of the interferometer. We will be conservative and assume that only one of the reflections is used. Now, if the incident laser power is  $I_0$ , then the power circulating within the interferometer is  $\mathcal{F}I_0$ , where  $\mathcal{F}$  is the recycling factor. The observed signal is proportional to the internal field and the reference field (see e.g. ref. [8]), so

$$\text{Signal} \propto \sqrt{\mathcal{F}I_0} \sqrt{\frac{1}{2}\epsilon\mathcal{F}I_0}. \quad (1)$$

The noise power is proportional to the light power:

$$\text{Noise}^2 \propto \mathcal{F}I_0(C + \frac{1}{2}\epsilon), \quad (2)$$

where  $C$  is the contrast ratio between the power leaking out and that circulating. So the signal to noise ratio  $S/N$  is given by

$$(S/N)^2 \propto \frac{\frac{1}{2}\epsilon\mathcal{F}I_0}{C + \frac{1}{2}\epsilon}. \quad (3)$$

If all the incident power is coupled into the interferometer, the power gain  $\mathcal{F}$  is just the reciprocal of the total losses for one round trip of the interferometer [7]:

$$\mathcal{F} = \frac{1}{\epsilon + C + NA^2}, \quad (4)$$

$NA^2$  being the loss associated with  $N$  reflections off mirrors of loss coefficient  $A^2$  in the arms of the interferometer. This gives a signal to noise ratio of

$$(S/N)^2 \propto \frac{\frac{1}{2}\epsilon I_0}{(C + \frac{1}{2}\epsilon)(\epsilon + C + NA^2)}. \quad (5)$$

It is clear that there will be an optimum value for the fraction  $\epsilon$  of the power taken out for the reference beam: too low a value will allow the noise from the light leaking out to dominate, too high a value will reduce the power buildup. The optimum value is

$$\epsilon_{opt} = \left[2C(C + NA^2)\right]^{\frac{1}{2}}. \quad (6)$$

The resultant improvement in signal to noise ratio  $S$  compared to a non-recycled system is

$$S_{opt} = \frac{1}{(C + NA^2)^{\frac{1}{2}} + (2C)^{\frac{1}{2}}}. \quad (7)$$

(The factor of 2 is absent for an arrangement, such as internal modulation, that uses all of the light reflected out of the interferometer [11].) This equation tells us that the contrast ratio should be considerably less than the loss  $NA^2$  in the arms of the interferometer if the best sensitivity is to be achieved. It is, perhaps, easier to see this if we express the result in terms of the normalised contrast  $C_n = C/NA^2$ . The signal to noise ratio can then be compared to the maximum value it could have if the contrast was perfect:

$$\frac{(S/N)}{(S/N)_{max}} = \frac{1}{(C_n + 1)^{\frac{1}{2}} + (2C_n)^{\frac{1}{2}}}. \quad (8)$$

This relation is plotted in figure 3. Note the slow variation of  $S/N$  with contrast. Poor contrast may significantly degrade the sensitivity even when the power leaking out is somewhat smaller than the losses in the arms of the interferometer: it is necessary to have a normalised contrast of  $\leq 3.10^{-2}$  if no more than 20% of the signal to noise ratio is to be lost.

We need to evaluate the implications for the mirror figure and alignment. In order to do this, it is helpful to expand the beam in terms of its normal spatial modes. The reasons for doing this are threefold: any distortion of the wavefront may be represented as the introduction of higher order modes, the magnitudes of which remain constant as the beam propagates through free space; modes in one beam only interfere with modes in another if they are of the same order (i.e. modes are orthogonal); and it is relatively easy to calculate how the different modes resonate if they are enclosed in a cavity (such as the signal recycling cavity). We can choose to use a Cartesian co-ordinate system,

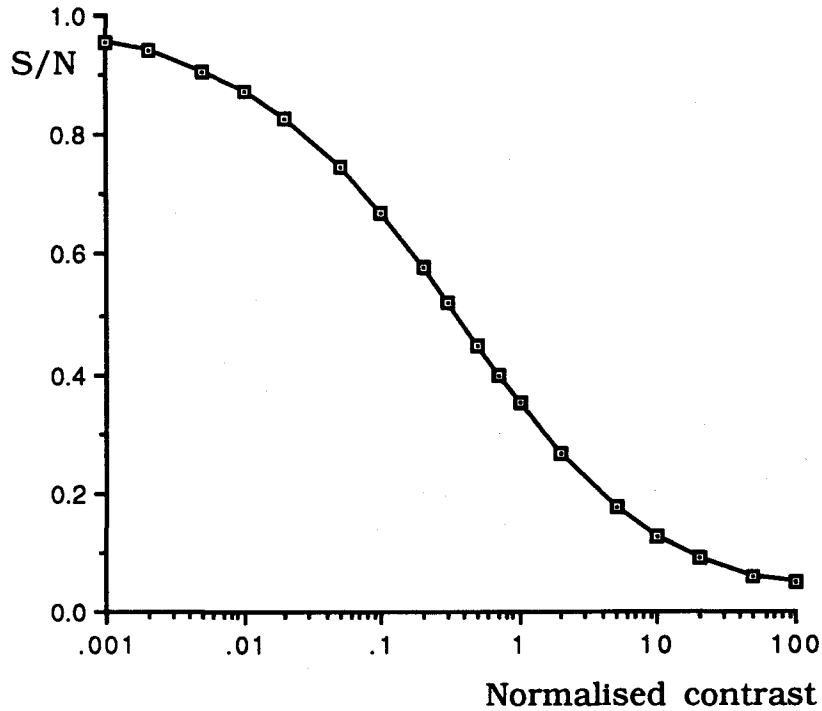

Figure 3: The signal to noise ratio  $S/N$ , compared to its maximum value, for different fringe contrasts.

in which case the field distribution  $E(x, y)$  may be written as

$$E(x, y) = \sum_{m=0}^{\infty} \sum_{n=0}^{\infty} A_m h_m(x) A_n h_n(y). \quad (9)$$

$A_m$  is the amplitude coefficient for the  $m$ th mode. The normal modes  $h_m(x)$  are Hermite-Gaussian functions for spherical mirrors [12]. If we normalise the co-ordinate to the beam radius  $w$ , so that  $X = \sqrt{2} x/w$ , then

$$h_m(X) = \frac{\Gamma(m/2 + 1)}{\Gamma(m + 1)} H_m(X) e^{-X^2/2}, \quad (10)$$

where  $H_m(X)$  is a Hermite polynomial. The Gamma functions  $\Gamma$  are just normalisation factors.

Now, if we imagine two beams interfering, one of which consists purely of the fundamental mode while the other has higher modes introduced by some distortion, the field emerging from the output port of the beamsplitter is

$$E_{out} = \frac{A_0}{\sqrt{2}} \left[ \frac{\Delta A_0}{A_{00}} h_0 + \sum_{m=1}^{\infty} \frac{A_m h_m}{A_{00}} \right], \quad (11)$$

where  $A_0$  is the incident amplitude and  $A_{00}$  is the amplitude in each arm. Note that  $E_{out}$  is normalised to the field amplitude incident on the beamsplitter. Using the fact that the original distortion conserved energy, we can say that the field leaking out gives a fractional power loss of

$$\frac{\Delta I}{I} = \frac{\Delta A_0}{A_{00}}. \quad (12)$$

So we can calculate the effective loss if we know the mode amplitudes. But, for an arbitrary field distribution  $E(X)$ , we can use the mode orthogonality to write

$$A_m = \frac{\int_{-\infty}^{\infty} E(X) h_m(X) dX}{\int_{-\infty}^{\infty} h_m h_m^* dX}. \quad (13)$$

The \* indicates complex conjugation. This useful formula may also be written as

$$A_m = \frac{1}{\Gamma(m/2 + 1) 2^m \sqrt{\pi}} \int_{-\infty}^{\infty} E(X) H_m(X) e^{-X^2/2} dX. \quad (14)$$

Note that  $H_0(0) = \Gamma(1) = 1$  and that  $\Gamma(N + \frac{1}{2}) = (\sqrt{\pi}/2^N)(2N - 1)!!$ . The corresponding power in the  $m$ th order mode, relative to that in the fundamental, is

$$I_m \equiv g_m A_m^2 = A_m^2 \frac{\int_{-\infty}^{\infty} h_m h_m^* dX}{\int_{-\infty}^{\infty} h_0 h_0^* dX} \quad (15)$$

with the expression for the geometry factor  $g_m$  reducing to

$$g_m = \left[ \frac{\Gamma(m/2 + 1)}{\Gamma(m + 1)} \right]^2 2^m m!. \quad (16)$$

For example,  $g_0 = 1$ ,  $g_1 = \pi/2$  and  $g_2 = 2$ . These relations allow us to calculate the amplitudes and powers of the various modes corresponding to an arbitrary wavefront distortion.

Let us take an example, that of one arm of the interferometer being misaligned by an angle  $\theta$ , corresponding to a phase gradient  $\phi(x) = 2\pi\theta x/\lambda$  across the beam,  $\lambda$  being the wavelength of the light. Application of equation 14 then gives an expression for the resultant mode amplitudes :

$$\frac{A_m}{A_{00}} = \frac{(i\theta/\theta_c)^m e^{-(\theta/\theta_c)^2}}{\Gamma(m/2 + 1)}, \quad (17)$$



where the characteristic angle  $\theta_c = \lambda\sqrt{2}/\pi w$ . So most of the additional excitation produced by a small angular misalignment ( $\theta \ll \theta_c$ ) is of the first order mode:

$$|A_1| \approx \frac{2}{\sqrt{\pi}}(\theta/\theta_c)A_{00}, \quad (18)$$

with the fundamental mode amplitude being reduced to

$$A_0/A_{00} = e^{-(\theta/\theta_c)^2} \approx 1 - (\theta/\theta_c)^2. \quad (19)$$

The fractional power loss out of the beamsplitter is then

$$\Delta I/I = 1 - e^{-(\theta/\theta_c)^2} \approx (\theta/\theta_c)^2, \quad (20)$$

with the approximation valid for small misalignments. Note that most of the emerging energy is contained in higher order modes. The power in the fundamental is  $\sim (\theta/\theta_c)^2$  times that in the first order mode. This is a point that we will return to later.

If this power loss is not to degrade the potential sensitivity of the interferometer, it should be considerably smaller than the losses associated with arms of the interferometer. Thus, if an interferometer of length  $l$  has  $N$  reflections in each arm, with a mirror loss coefficient  $A^2$ , the requirements on angular alignment are

$$\theta \ll (2\lambda NA^2/\pi l)^{\frac{1}{2}} \approx 4.10^{-7} \left[ \frac{N}{30} \right]^{\frac{1}{2}} \left[ \frac{l}{3 \text{ km}} \right]^{-\frac{1}{2}} \left[ \frac{A^2}{5.10^{-5}} \right]^{\frac{1}{2}} \left[ \frac{\lambda}{0.5 \mu\text{m}} \right]^{\frac{1}{2}} \text{ rad.} \quad (21)$$

This is quite a tough requirement—remember that our discussion of the effect of poor contrast suggested that the safety factor by which the inequality 21 is satisfied should be  $\sim 5$ .

Two lessons can be drawn immediately from this analysis. First, that the required alignment accuracy is very high and will not be easy to achieve. Second, that the problem is so severe because, although interference gives the beamsplitter a very high effective reflectivity for the fundamental mode of the system, the higher order modes representing any wavefront distortion see a low reflectivity and are therefore able to transport power out of the optical system very easily.

This loss of power via other spatial modes can also be seen when we try to estimate the required mirror figure. If we consider a single spatial Fourier component of a mirror deformation which imposes a phase ripple  $\Phi_0 \cos \Omega X$  on the light,  $\Omega$  being the normalised angular spatial frequency, then equation 14 tells us that the amplitude in the  $m$ th mode is

$$A_m = \frac{1}{\pi} \int_{-\infty}^{\infty} H_m(X) e^{-X^2} e^{-i\Phi_0 \cos \Omega X} dX. \quad (22)$$

If we assume that the imposed phase ripple is small ( $\Phi_0 \ll 1$ ), this integral reduces to a standard form. A little algebra then gives the amplitude remaining in the fundamental mode:

$$|A_0| \approx \left[ 1 - \frac{1}{2} \Phi_0^2 (1 - e^{-\Omega^2/2})^2 \right]^{\frac{1}{2}}, \quad (23)$$

while the amplitude in higher modes is, for even  $m$ ,

$$|A_m| \approx \frac{\Phi_0}{2^{\frac{1}{2}m+1} m!} (\Omega/\sqrt{2})^m e^{-\Omega^2/2}. \quad (24)$$

So deformations of spatial frequency  $\Omega$  typically excite modes of order  $m \approx \Omega$ . The power lost from the system due to this cosinusoidal phase ripple is

$$\Delta I/I \approx \frac{1}{4} \Phi_0^2 (1 - e^{-\Omega^2/2})^2. \quad (25)$$

Note the dependence on the spatial scale of the deformation ( $\lambda_{spatial} = \sqrt{2} \pi w / \Omega$ ): it is figure errors on length scales of the beam size and less that matter. So big beams require accurate figure on large length scales.

If we take the case of small scale deformation  $\Omega \gg 1$ , and express  $\Phi_0$  in terms of a mirror figure error  $z_0$  ( $\Phi_0 = 4\pi z_0/\lambda$ ), then the fractional power loss is just

$$\Delta I/I \approx (2\pi z_0/\lambda)^2. \quad (26)$$

This loss of power is particularly serious for an interferometer with delay lines in its arms, for the figure error seen on each bounce will probably be essentially uncorrelated, taking about the same amount of power out of the fundamental mode on each reflection. In this case, the mirror figure required for the power loss to be less than that due to absorption and scattering is just

$$\frac{z_0}{\lambda} \ll \left[ \frac{A^2}{4\pi^2} \right]^{\frac{1}{2}} \approx \frac{1}{1000} \left[ \frac{A^2}{5.10^{-5}} \right]^{\frac{1}{2}}. \quad (27)$$

This is evidently an extremely stringent requirement for the mirror figure.

This last result is only correct if the mirror figure errors at each reflection are uncorrelated. If they are not, then the amplitudes generated at each bounce must be added with appropriate phase. In this way it is possible for mirror figure to be somewhat less critical. An example is when a cavity forms the multi-bounce system: here the beam sees the same shape at each bounce on a particular mirror, the mode couplings are coherent, the result being that a new shape of fundamental mode is formed, with phase fronts following the mirror surfaces. (This point will be considered

further when dual recycling is discussed.) The requirement on mirror figure for a cavity is

$$\frac{z_0}{\lambda} \ll \left[ \frac{NA^2}{4\pi^2} \right]^{\frac{1}{2}} \approx \frac{1}{150} \left[ \frac{N}{30} \right]^{\frac{1}{2}} \left[ \frac{A^2}{5 \cdot 10^{-5}} \right]^{\frac{1}{2}}. \quad (28)$$

It is straightforward to use the mode formalism to calculate the power lost due to other types of wavefront distortion. For example, a problem of some practical importance is the required curvature accuracy of the mirrors. If the two interfering beams have curvatures  $\mathcal{R}_1, \mathcal{R}_2$ , the fractional power emerging from the beamsplitter will be

$$\frac{\Delta I}{I} = \frac{1}{2} \left[ \frac{\pi w^2}{\lambda} \left( \frac{1}{\mathcal{R}_1} - \frac{1}{\mathcal{R}_2} \right) \right]^2, \quad (29)$$

or, if the beams have sizes  $w_1, w_2$ , then

$$\frac{\Delta I}{I} = \frac{(1 - w_1/w_2)^2}{2(1 + (w_1/w_2)^2)} \approx \left[ \frac{\Delta w}{2w} \right]^2. \quad (30)$$

All of these examples indicate that very high accuracy of mirror curvature, figure and alignment will be needed if the full potential benefits of power recycling are to be obtained. This accuracy is necessary because it is so easy to lose power out of the beamsplitter: any distorted light sees a high transmission to the outside world. We would expect this latter property to be modified if a mirror is placed in the output beam, as it is in dual recycling. We shall discuss this in the next section. Before we do so, we should, perhaps, remind the reader that detuned recycling [13], requiring as it does a very high power buildup in the recycling cavity, is even less tolerant of wavefront distortion than simple power recycling.

### 3 Distortion in Dual Recycling

If a simple two-mirror cavity is misaligned or its mirrors are slightly distorted, then the normal modes of the cavity will also change in direction, position or shape. Perfectly spherical mirrors are not required for a stable mode to exist [14], though sufficiently large deviations will induce instability. In such a situation, the requirements on mirror figure and alignment for near-maximal power buildup are much less severe than for power recycling. For example, we have seen that  $(\theta/\theta_c)^2 \ll NA^2 \sim 10^{-3}$  is needed in power recycling, whereas  $(\theta/\theta_c)^2 \ll 1$  is sufficient for a simple cavity. Roughly speaking, this is because in a simple cavity, any light scattered out of the fundamental mode sees a high reflectivity when it next encounters a mirror (as long it is not deviated by enough to miss the mirror). The deviated light is therefore reflected around the

system many times, forming a new mode in the process. This does not happen in power recycling because distorted light is immediately lost, with no opportunity to re-traverse the optical system and contribute to a new normal mode. This argument suggests that dual recycling, in which a mirror ( $M_3$  in figure 2) is placed at the output of the detector to partially reflect light back in, should be much more like a simple cavity in its behaviour. We shall show that this is indeed the case, though with some significant complications.

In order to determine the power buildup inside the recycling system and the power leakage out of it we need to calculate how the light that is directed towards the signal recycling mirror  $M_3$  resonates in the signal recycling cavity (the cavity formed by  $M_3$  and the mirrors in the arms of the interferometer). We also need to know how this distorts the internal mode, and how efficiently this mode couples to both the local oscillator at the output and the input laser beam. Let us first consider only the problem of how much power is lost via the output port. As we saw in the last section, the light emerging from the output port in power recycling consists mainly of higher order modes resulting from the distortion, with a smaller amount of energy contained in the fundamental mode. The amplitude of the  $m$ th mode emerging from the signal recycling mirror  $M_3$  will be modified by how it resonates in the signal recycling cavity, being multiplied by the resonance factor  $\gamma_m$ :

$$\gamma_m = \frac{T_{3m}}{(1 - R_{3m}R_{Am})(1 + F'_{sm} \sin^2(\delta_m/2))^{1/2}}, \quad (31)$$

where  $T_{3m}$  and  $R_{3m}$  are the amplitude transmission and reflection coefficients of the signal recycling mirror  $M_3$  for the  $m$ th mode,  $R_{Am}$  is the corresponding reflectivity of the arms of the interferometer,  $\delta_m$  is the phase offset in the signal recycling cavity for the  $m$ th mode and the signal finesse  $F_{sm}$  is given by

$$\frac{4F_{sm}^2}{\pi^2} = F'_{sm} = \frac{4R_{3m}R_{Am}}{(1 - R_{3m}R_{Am})^2} \quad (32)$$

The total fractional power loss is then

$$\frac{\Delta I}{I} = \frac{1}{2} \left[ \left( \frac{\Delta A_0}{A_{00}} \right)^2 \gamma_0^2 + \sum_{m=1}^{\infty} \left( \frac{\Delta A_m}{A_{00}} \right)^2 \gamma_m^2 g_m \right], \quad (33)$$

or, if  $\gamma_m$  is approximately the same for all higher modes containing significant power,

$$\frac{\Delta I}{I} \approx \frac{\Delta A_0}{2A_{00}} \left[ \frac{\Delta A_0}{A_{00}} \gamma_0^2 + \gamma_m^2 \left( 2 - \frac{\Delta A_0}{A_{00}} \right) \right]. \quad (34)$$

The signal recycling cavity will have a non-confocal geometry, so all modes other than the fundamental will be off resonance. The power loss in higher order modes

is therefore reduced by a factor  $\sim 1/T_{3m}^2$ . Since higher modes contain most of the leaking power at low distortion levels, the wasted power will be smaller. As long as the deformations are sufficiently small ( $\frac{\Delta A_0}{A_{00}} \gamma_0^2 < 1$ ), the power loss in dual recycling will be less than in power recycling. The value of  $\gamma_0$ , hence the amount of power leaking out in the fundamental, will depend on how the detector is operated.

### 3.1 Broadband Operation

In broadband mode, the signal recycling cavity is arranged to be resonant at the original laser frequency, with a bandwidth comparable to the observing frequency. The amplitude of any of the fundamental mode leaking out because of distortion is then *enhanced* by the about same factor as the gravitational wave signal. This means that the advantages of dual recycling are restricted to situations in which the distortion levels are quite low. This is illustrated in figure 4, which shows how much the power loss due to a misalignment is reduced in broadband dual recycling, for various different signal recycling mirror transmissions. The power loss reduction factor is the ratio of the fractional power loss with only power recycling to that with dual recycling, at the same distortion level. Remember that the normalised misalignment is  $\theta/\theta_c$ . This calculation, together with all of the others in this section, assumes a 30 bounce, 3 km interferometer. While we will take angular misalignment as our example, similar results should hold for more general distortions. The precise value of the improvement factor with dual recycling will depend upon the geometry of the signal recycling cavity, which determines how the various modes resonate. For this calculation, we have assumed  $\sin \delta_1 = 1$ . As expected, the resonant suppression of the first order mode leads to a considerable improvement in the power loss for small misalignments. Sensible values for the transmission  $T_3$  are determined by the requirement for the signal bandwidth to be approximately equal to the gravitational-wave frequency  $\nu_{g0}$  for which the detector is optimised. This implies [8] that  $(F_s/\pi)\sin(\pi\nu_{g0}Nl/c) \approx 1$ , with  $l$  the length of the interferometer and  $c$  the speed of light, giving a transmission

$$T_3^2 \approx 1 - [1 + 2\sin(\pi\nu_{g0}Nl/c)]^{-2} . \quad (35)$$

For example, if  $N = 30$ ,  $l = 3$  km and  $\nu_{g0} = 150$  Hz, then  $T_3^2 \approx 0.4$ . In this case, the misalignment angle which gives a fractional power loss of  $2.10^{-4}$ , for example, is  $0.035\theta_c$ , a factor of 2.5 larger than with the same power recycling system. So, while broadband dual recycling does give greater tolerance of distortion, the benefits are limited by the requirement that the bandwidth should not be narrowed too much.

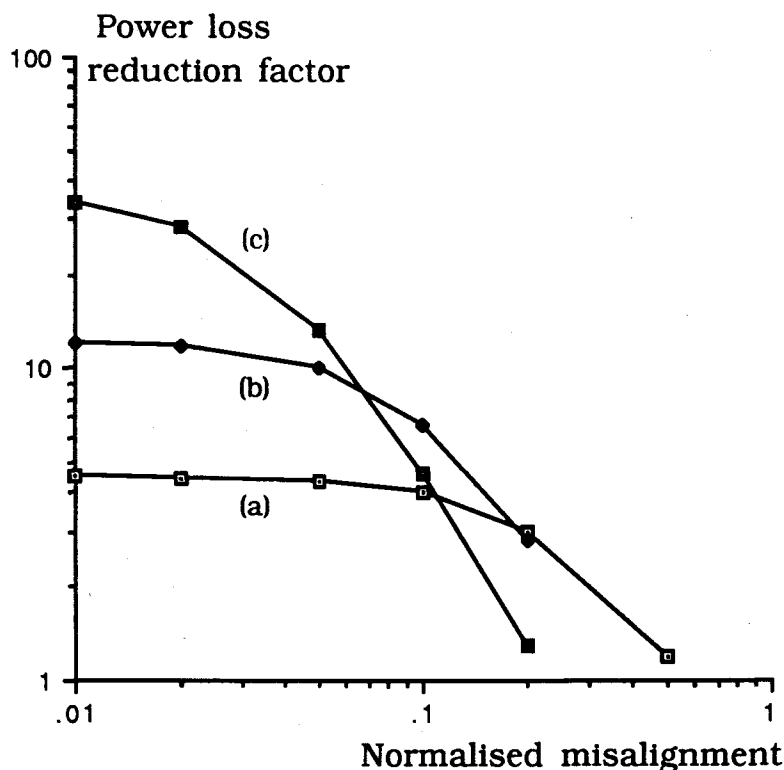

Figure 4: *The reduction of power leakage in broadband dual recycling compared with power recycling: (a)  $T_3^2 = .5$ ; (b)  $T_3^2 = .25$ ; (c)  $T_3^2 = .1$ . Angles are in units of  $\theta_c$ .*

### 3.2 Narrowband Operation

It can be seen in figure 4 that for large misalignments, high signal finesses give worse power losses. This is because the component of the light at the laser frequency in the fundamental mode is resonantly enhanced. In this situation, it is to be expected that lower power loss will be obtained if the signal recycling cavity is tuned so that it is resonant for one of the gravitational-wave induced sidebands. The original laser frequency will then not be perfectly resonant, but will have a mode amplitude enhancement factor  $\gamma_0$  given by equation 31 with  $\delta_0 = 2\pi N l \nu_{g0}/c$ . A higher signal finesse can then reduce the power in all modes at the original frequency. This is illustrated in figure 5. The distortion tolerance of narrowband systems is clearly significantly better than that of broadband systems, especially at high distortion levels. High signal finesses now always give lower power loss, the power loss reduction factor at low distortion levels being  $\sim 4/T_3^2$ . This improvement factor could easily be  $\sim 10^3$  for genuinely narrowband detectors, corresponding to a relaxation of the requirements for mirror

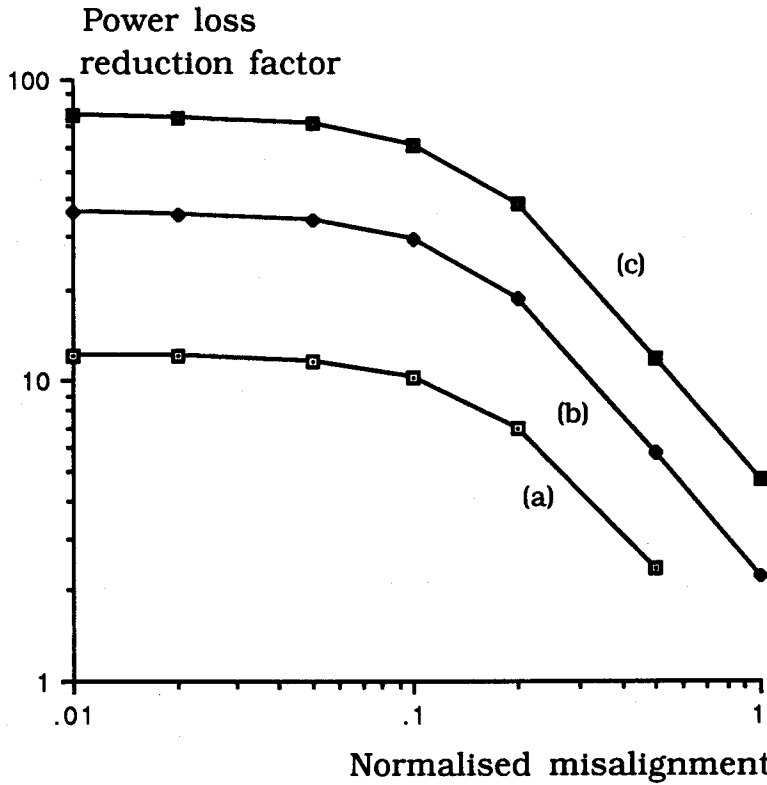

Figure 5: *The reduction factor for power loss in narrowband dual recycling, tuned to 150 Hz: (a)  $T_3^2 = .25$ ; (b)  $T_3^2 = .1$ ; (c)  $T_3^2 = .05$ .*

figure by a factor of  $\sim 30$ .

In narrowband mode, a slightly lower value of the transmission  $T_3^2$  of the signal recycling mirror is required to give a particular bandwidth than in broadband mode [8]. This is because the signal sidebands at the frequency at which the detector has been optimised are at the centre of the detector tuning curve rather than being down the side of it. This means that a choice of  $T_3^2 = 0.1$  will give a bandwidth of  $\sim 75$  Hz, centred on 150 Hz, for our 3 km, 30 bounce interferometer. Such a system would reduce the power loss due to small deformations by a factor  $\sim 30$  compared with power recycling. The alignment stability required for a fractional power loss of  $2 \cdot 10^{-4}$  is relaxed by a factor of  $\sim 5$ . The advantages of such a tuned optical system may well be significant.

Consider the case of an optimally narrowbanded detector, with  $T_0^2 = T_3^2 = NA^2$ . The fractional power loss produced by a small misalignment  $\theta$  (each arm being oppositely misaligned by  $\theta/2$ ) is then

$$\Delta I/I \approx \frac{1}{2} (\theta/\theta_c)^2 NA^2 . \quad (36)$$

This will limit the overall power gain  $\mathcal{F}$  to

$$\mathcal{F} \approx \frac{1}{NA^2 \left[1 + \frac{1}{2} (\theta/\theta_c)^2\right]} \approx \mathcal{F}_{max} \left[1 - \frac{1}{2} (\theta/\theta_c)^2\right]. \quad (37)$$

But this reduction in power buildup is just the same as that of a simple two-mirror cavity which is misaligned with respect to the input beam by an angle  $\theta/2$  (cf equation 19). So a dual recycling system with equal high reflectivity mirrors does indeed look like a simple two-mirror cavity for small misalignments.

It is interesting to see why the similarity of behaviour of a dual recycling system and a two mirror cavity breaks down at high distortion levels, or when the fundamental mode is resonant in the signal recycling cavity. In such situations, the deformation significantly changes the level of the fundamental mode. In a simple cavity, the interference of the fundamental mode with the incoming laser beam stops power leaking out and allows power to couple in efficiently. However, in dual recycling the component of the fundamental mode which emerges through the output mirror  $M_3$  has no beam to interfere with, so power is lost relatively easily. In principle, the broken symmetry might be recovered if some of the laser light was injected into the interferometer through  $M_3$ , with just the right amplitude and phase to cancel the emerging fundamental mode. The dual recycling system would then be exactly equivalent to a two mirror cavity.

### 3.3 Mode distortion

We have seen that dual recycling does reduce the power loss due to distortion from an interferometer. We still need to consider the formation of new internal modes and how these modes couple to the incoming laser and reference beams.

At this point the reader should be reminded that the argument about the formation of new normal modes is only applicable for distortions which are of large enough scale for the light removed from the fundamental mode to still hit the signal recycling mirror—light which is scattered at high angles is gone for good! However, the scales for which it works are probably those that are of the most practical significance. Nevertheless, it may well be sensible to use recycling mirrors of somewhat larger diameter than might naively be thought necessary.

Just as in a two mirror cavity, any distortion of the wavefront inside the dual recycling system will lead to the normal modes having a different shape. We will not attempt here to rigorously derive the form of the new normal modes. However, several important features can be seen without this. First, if the distortion level within the interferometer is  $\sim \lambda/100$ , say, the distortion of the mode shape will be of the same order. Also, the result of two beams adding at the beamsplitter, with one misaligned by



$\theta$ , will look like a beam misaligned by  $\theta/2$ . Similarly, if the curvatures are mismatched by  $\Delta\mathcal{R}/\mathcal{R}$ , the curvature of the new mode will differ by  $\Delta\mathcal{R}/2\mathcal{R}$ . More generally, if the beam in one arm of the interferometer is distorted so that the field distribution in that arm is

$$E(X) = \frac{A_0}{A_{00}} h_0(X) + \sum_m \frac{\Delta A_m}{A_{00}} h_m(X), \quad (38)$$

then the shape of the new mode will look roughly like

$$h'_0(X) \approx \left(1 - \frac{\Delta A_0}{A_0}\right) h_0(X) + \sum_m \frac{\Delta A_m}{2A_{00}} h_m(X), \quad (39)$$

with

$$\left(1 - \frac{\Delta A_0}{A_0}\right)^2 + \sum_m \frac{\Delta A_m^2}{4A_{00}^2} g_m = 1. \quad (40)$$

This last equation just represents conservation of energy. To see that this gives the correct answer, consider the case of a small misalignment  $\theta$  in one arm. Only the fundamental and first order modes have significant amplitude, so

$$\left(1 - \frac{\Delta A_0}{A_0}\right)^2 + \left(\frac{\Delta A_1}{2A_{00}}\right)^2 g_1 = 1, \quad (41)$$

or

$$\frac{\Delta A_0}{A_0} \approx \frac{1}{2} \left(\frac{\Delta A_1}{2A_{00}}\right)^2 g_1 = \left(\frac{\theta}{2\theta_c}\right)^2. \quad (42)$$

We have used equation 18 to obtain the last result. Now a change in  $\Delta A_0/A_0$  at the input must correspond, by equation 19, to an angular change  $\theta_i$  of

$$(\theta_i/\theta_c)^2 = \Delta A_0/A_0, \quad (43)$$

which means that  $\theta_i = \theta/2$ . So the angle of the new mode changes by half the angular change of only one arm, as expected.

We can now calculate the fraction of the energy in the incident laser beam that will be coupled into the distorted internal mode. This may be considered obvious, or equations 13 and 15 may be used to confirm that the coupling of a pure fundamental mode is just

$$\frac{I'_0}{I_0} = \left(1 - \frac{\Delta A_0}{A_0}\right)^2 = 1 - \sum_m \frac{\Delta A_m^2}{4A_{00}^2} g_m, \quad (44)$$

where  $g_m$  is the geometrical factor defined in equation 16. For an angular misalignment  $\theta$ ,

$$\frac{I'_0}{I_0} = 1 - \frac{1}{2} (\theta/\theta_c)^2. \quad (45)$$

It is evident that the coupling efficiency is only reduced significantly when the distortion is quite large. Small deformation levels ( $\theta/\theta_c \ll 1$  or phase deviation  $\Phi_0 \ll 1$ ) leave enough overlap of the mode shapes for efficient coupling. In most situations, the major problem will be the loss of power through the output of the interferometer.

The distortion of the internal mode may reduce the efficiency with which the signal is detected. If the output signal is produced by beating the emerging signal sidebands with a reference beam which is derived from the incident laser light, or if the output beam is passed through a mode selector, then the output coupling efficiency is the same as that at the input. On the other hand, if the reference beam is derived from the internal beam and there is no mode cleaner on the output, then there is no additional loss of signal. In addition, there is a minor difference between the characteristics of interferometers with delay lines or cavities in the arms. In a delay line interferometer, the circulating mode is always the one that generates the signal. A cavity interferometer, on the other hand, can have different mode structure in its different cavities. This will depend on the place at which the distortion occurs. It might be thought that this would severely limit the increase in power build up in the arms of a cavity interferometer if the distortion is at the beamsplitter, for example. However, this will only be a serious problem if the distortion level is large enough to result in poor overlap between the mode incident upon and the mode inside the cavity. For reasonably small distortion, the enhancement of signal to noise ratio due to dual recycling will only be slightly smaller for cavity interferometers than for those using delay lines.

We have seen that the component of the circulating light in the original fundamental mode may be considerably increased by dual recycling, even though the light reflected back by the signal recycling mirror is predominantly in higher order modes. This paradox may be resolved by realising that the original modes of the system are *not* normal modes of the new, distorted system. The new modes are not orthogonal to the old modes. The new fundamental mode contains both the original fundamental mode and the modes representing the distortion, thus producing coupling between the original modes which allows power to be transferred back to the original mode. So distorted light reflected back from the signal recycling mirror couples with high efficiency into the new fundamental mode. We will present some experimental evidence for this in section 3.4, but an explicit calculation of the coupling is also interesting.

The change  $\Delta A'_0$  in the amplitude of the new fundamental mode produced by reflecting back distorted light that would otherwise be lost is

$$\Delta A'_0 = \frac{\sum_m \int_{-\infty}^{\infty} \Delta A_m h_m(X) \frac{\Delta A_m}{2A_{00}} h_m^* dX}{\int_{-\infty}^{\infty} h'_0(X) h'_0{}^*(X) dX} \quad (46)$$

So the distorted light couples back to the fundamental to produce an amplitude en-

hancement of

$$\frac{\Delta A_0}{A_{00}} = \sum_m \frac{\Delta A_m^2}{2A_{00}^2} g_m, \quad (47)$$

which is an increase in energy of the new mode of

$$\Delta I'_0 = 2A'_0 \Delta A'_0 = \sum_m \Delta A_m^2 g_m. \quad (48)$$

But this is just the energy in the original distortion. So the distorted light does, indeed, couple into the new normal mode efficiently. Not only does dual recycling increase the circulating power, it also increases the useful power.

We have seen that dual recycling does, indeed, give the interferometer a greater tolerance to distortions of the wavefront. For tuned, narrowband systems this improvement factor can be very high. For broadband systems, the improvement factor is still significant, but the requirement that the transmission of the signal recycling mirror must be kept fairly high in order to retain the bandwidth is a limitation. Before discussing a method of improving this situation, we shall describe an experimental test of some of the ideas that we have been considering.

### 3.4 A dual recycling experiment

We have recently completed an experimental demonstration that dual recycling does, indeed, work. The main purpose of this experiment was to test the predictions concerning the enhancement of signal to noise ratio, and the functioning of the control systems. These results will be described elsewhere[15]. The experiment also provided an opportunity to test predictions of the tolerance of a dual recycling interferometer to wavefront distortion.

The basic layout of the experiment is indicated in figure 6. It consists essentially of a simple, one-bounce Michelson interferometer with two recycling mirrors, each of 10% transmission. The end mirrors had a radius of curvature of 5 m, the recycling mirrors were of curvature 70 cm and the length of the recycling cavities was 59 cm. The rest of the optics was there to make sure that the interferometer functioned correctly, with an external modulation scheme to extract the signal. The light used to sense the length of the signal recycling cavity was frequency shifted in a double-passed acousto-optic modulator by two free spectral ranges of the signal recycling cavity ( $\sim 500$  MHz); this was done primarily for noise reasons, but alteration of the drive frequency to the acousto-optic modulator was a convenient way of adjusting the tuning of the signal recycling cavity. An argon ion laser (Spectra-Physics model 165, at 514.5 nm) was used as the light source for the experiment.

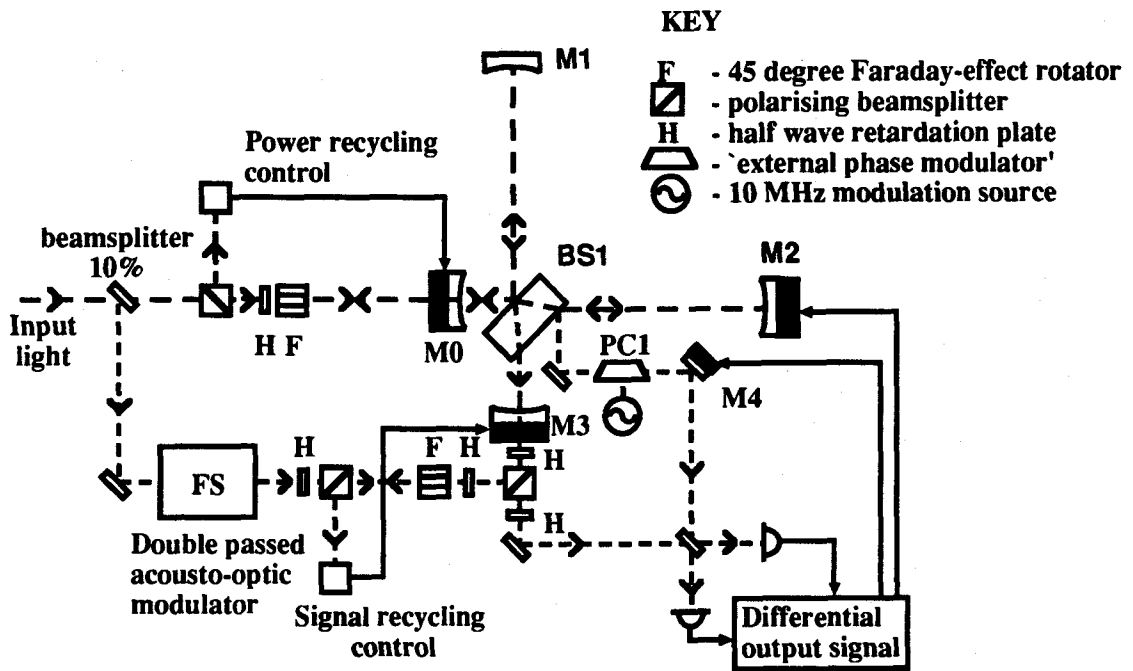

Figure 6: *The optical layout of the dual recycling experiment.*

One of the mirrors in the arms of the interferometer was mounted on a piezoelectric transducer (Burleigh PZAT 80) that enabled its angle to be changed in a controllable way. This allowed us to study the effects of misalignments. We measured the fractional power loss out of the beamsplitter as a function of misalignment angle for both power recycling and dual recycling. The results are shown in figure 7. The top set of points represents the observations with only power recycling. It can be seen that at very small misalignment angles, the fractional power loss was constant at  $\sim 4.10^{-4}$ . This was probably the result of a distortion of a mirror. The curve that is plotted is a prediction of the power loss assuming both this constant loss and the alignment dependence of equation 20. This model seems to be in good agreement with observation. The lower set of points in figure 7 represent the observations with broadband dual recycling. The first thing to notice is that they are lower—dual recycling does improve the fringe contrast. The fractional power loss at small misalignments was only  $\sim 2.10^{-5}$ , a factor of  $\sim 20$  better than with only power recycling. The curve shows the theoretical prediction of this power loss, with the assumption that essentially all of the power leaking out at very small misalignments was in the second order mode. For our cavity geometry,

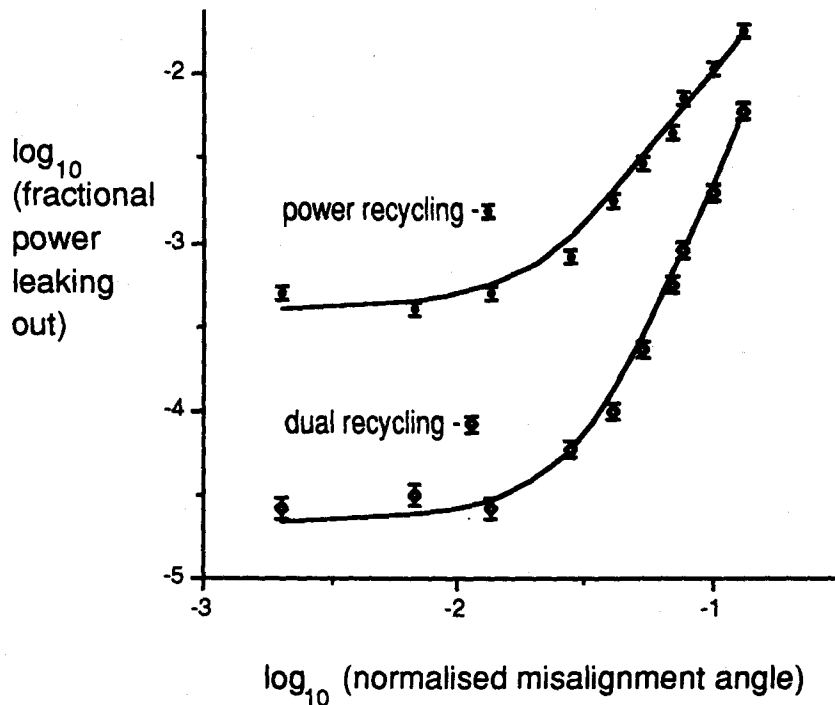

Figure 7: Fractional power loss for different misalignments, with angles again in units of  $\theta_c$ . The top curve indicates the results for power recycling. The lower points compare observation and expectation for dual recycling.

$\gamma_1 = 0.175$  and  $\gamma_2 = 0.236$  (with  $\gamma_4 = 0.163$ ). Once more, the agreement between prediction and observation seems excellent.

We also wanted to test whether the power build up was better within the dual recycling system when the interferometer was misaligned. The circulating power was monitored by measuring the power reflected off the back face of the beamsplitter. The maximum power enhancement from recycling was a factor of 32, the difference between this and the value of 37 predicted from the transmission of the recycling mirror being due to slightly imperfect mode-matching and the presence of RF phase modulation. This rather modest power gain necessitated quite large misalignments if the effects on the power build up were to be evident. The results for power recycling alone are shown in table 1. For the dual recycling interferometer, we measured both the power build up and the size of the signal produced by a modulation of the length of one of the arms of the interferometer at 6 kHz. The results of these measurements are summarised in table 2. So dual recycling does increase the power build up within the interferometer, and in a way that is consistent with improvement in the contrast. Furthermore, the signal level is also increased. Reflecting light back from the signal recycling mirror

Misalignment angle $\theta_n$	Predicted power	Measured power
0.05	0.96	$0.95 \pm 0.05$
0.1	0.84	$0.80 \pm 0.05$
0.2	0.53	$0.60 \pm 0.05$

Table 1: *The power within the recycled interferometer as a function of the normalised misalignment angle. The power has been scaled so that the maximum observed power equals unity.*

Misalignment $\theta_n$	Expected power or signal	Measured power	Measured signal
0.10	0.93	$0.95 \pm 0.05$	$0.90 \pm 0.03$
0.14	0.89	$0.90 \pm 0.05$	$0.85 \pm 0.03$

Table 2: *The effect of relatively large misalignments on the power build-up and signal size with broadband dual recycling. The last three columns have been scaled to a maximum value of unity, as before.*

really does increase the useful power.

In figure 7 it is noticeable how the factor by which dual recycling improves the contrast decreases at high misalignment angles. This is the same fall off that we saw in figure 4. We argued earlier that this was due to a larger fraction of the power leaking out at high distortion levels being in the fundamental mode, which is resonant in the signal recycling cavity. To test this idea, we adjusted the resonant frequency of the signal recycling cavity by altering the drive frequency to the acousto-optic modulator. This reduced the amplitude of light leaking out in the fundamental and so improved the fringe contrast. The results are summarised in table 3. The external amplitude contrast  $\kappa$  is the ratio of the magnitude of the amplitude approaching the beamsplitter from  $M_0$  to that emerging from the interferometer. The agreement between the observed effects of detuning the signal recycling cavity and those predicted indicate that our model of resonating modes is a good representation of reality.

Another characteristic of the interferometer that we wanted to check was the coupling of motion of the signal recycling mirror to the output signal. This is important both as a test of our understanding and for the determination of tolerable noise levels. We can imagine a movement of  $M_3$  phase modulating any light hitting it, generating sidebands which resonate in the same way as a genuine signal. Motion of  $M_3$  should,

Detuning frequency (MHz)	Misalignment angle	Predicted contrast $\kappa$	Measured contrast $\kappa$	Power (normalised)
4	0.1	37.7	$40 \pm 3$	$1.00 \pm 0.05$
4	0.2	11.3	$10 \pm 1$	$0.80 \pm 0.05$
6	0.1	44.7	$48 \pm 3$	$1.00 \pm 0.05$
6	0.2	15.1	$15 \pm 2$	$0.90 \pm 0.05$
8	0.2	17.7	$21 \pm 2$	$0.95 \pm 0.05$

Table 3: *The external amplitude contrast  $\kappa$  and power build up in the misaligned dual recycling interferometer. The power is scaled to a maximum value of unity.*

External contrast $\kappa$	expected ratio	observed ratio
$30 \pm 2$	$9.5 \pm 1$	$12 \pm 2$
$85 \pm 4$	$28 \pm 2$	$24 \pm 4$

Table 4: *The size of the signal produced by motions of one of the interferometer mirrors compared to that produced by movement of the signal recycling mirror. The expected ratio assumes mode coupling efficiency  $\eta = 1$ , while the measured ratio allows for the different sizes of the motions which were imposed.*

therefore, be less important than motion of the beamsplitter by a safety factor

$$s = \eta\alpha, \quad (49)$$

where  $\alpha$  is the internal contrast (the ratio of the magnitude of the amplitude approaching the beamsplitter from  $M_0$  to that leaving the beamsplitter towards  $M_3$ ) and  $\eta$  is a factor which describes the efficiency of coupling of the distorted light incident on the signal recycling mirror into the detected mode. We have argued throughout this paper that this coupling is high,  $\eta \approx 1$ , and the experimental observations seem entirely consistent with this. The effect of a 3 kHz displacement of  $M_3$  on the output of the interferometer was measured for two values (10 and 28) of the internal contrast (the interferometer being slightly misaligned) and compared with the 6 kHz calibration signal. These results are summarised in table 4. It can be seen that equation 49 describes the results well with  $\eta = 1$ , within the experimental accuracy of  $\sim 20\%$ . So the distorted light reflected back from the signal recycling mirror does indeed merge efficiently with the new fundamental mode of the system.

In this experiment we have tested all of the essential features of our model of how distortion affects an interferometer. The excellent agreement between theory and experiment give us confidence in both our model and in ideas which are stimulated by it. We shall discuss one of these in the next section.

### 3.5 Dual recycling with a compound mirror

We have seen that most of the energy loss from the interferometer due to reasonably small distortions is contained in higher order modes of the beam; that the power in these modes is suppressed in a dual recycling system by a factor of  $\sim 1/T_{3m}^2$ , but that this factor is limited in the usual, broadband dual recycling arrangement by the requirement that  $T_{30}^2$  should not be so small as to reduce the signal bandwidth too much. This suggests that what we want is an optical system which gives a very small transmission for higher order modes while allowing quite a high transmission for the fundamental mode: *we need a geometry-selective mirror*. A device which fulfills this requirement is a non-confocal optical cavity. For example, if such a cavity is chosen to have mirrors of equal transmission coefficients which are large compared to the losses, then when the cavity is on resonance for the fundamental mode it has a high transmission  $T_{30}^2 \approx 1$  for the fundamental, but a low transmission for higher modes which are off resonance in the cavity. If this cavity were to take the place of the signal recycling mirror, as indicated in figure 8, signal could still be extracted quickly, with high bandwidth, while higher order modes would be reflected back to contribute to the new internal mode. Note that there is no particular requirement on the length of the extra cavity. Choice of a short ( $\sim 1$  m) cavity will be convenient (although mode-matching will be required) and the large cavity bandwidth will leave the signal frequency response unaffected.

The amplitude transmission coefficient for the  $m$ th mode through the output cavity or compound mirror  $M_3$  is

$$|T_{3m}| = \frac{T_c^2}{(1 - R_c^2)(1 + F'_c \sin^2(\delta_{cm}/2))^{1/2}}, \quad (50)$$

where  $T_c$  and  $R_c$  are the amplitude transmission and reflection coefficients, respectively, of the mirrors in  $M_3$  and  $\delta_{cm}$  is the phase offset for the  $m$ th mode in the compound mirror. The fundamental transmission  $|T_{30}|$  may be varied from  $\sim 1$  down to quite small values by tuning the operating point  $\delta_{c0}$  of the cavity. This will alter the sensitivity-bandwidth combination of the detector. Modes of order greater than zero will be well off resonance for all cavity tunings of interest, so their transmission coefficients will be

$$|T_{3m}| \approx T_c^2/2, \quad (51)$$

which means that the power emerging in higher order modes will be suppressed by a factor of

$$\gamma_m^2 \approx (T_c^2/2)^2. \quad (52)$$

So even a conservative choice of  $T_c^2 = 2.10^{-2}$ , which would give a finesse of 150, would reduce the power emerging in higher order modes by a factor of  $\sim 10^4$ ! This is clearly



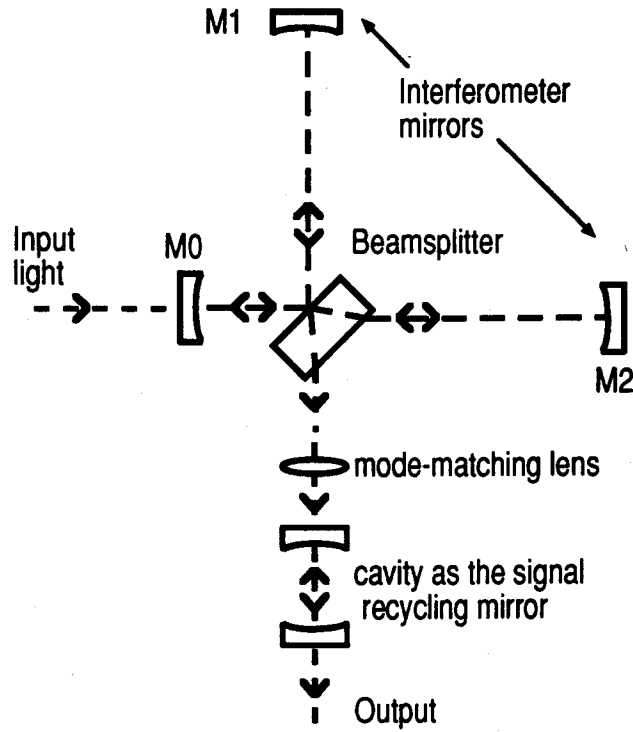

Figure 8: *The optical arrangement for dual recycling with a compound signal-recycling mirror.*

very good. There is still the power leaking out in the fundamental, but this will usually be a very small fraction of the original power loss. Rewriting equation 34, the expression for the power leaking out is

$$\frac{\Delta I}{I} \approx \frac{\Delta A_0}{2A_{00}} \left[ \frac{\Delta A_0}{A_{00}} \gamma_0^2 + (T_c^2/2)^2 \left( 2 - \frac{\Delta A_0}{A_{00}} \right) \right]. \quad (53)$$

If we take our example of a small misalignment, the power leaking out, mostly in the fundamental, is only

$$\Delta I/I \approx \frac{1}{2} (\theta/\theta_c)^4 \gamma_0^2, \quad (54)$$

which is considerably better than in the conventional mode of operation of dual recycling. This is illustrated in figure 9 and 10, which show the improvement in the power loss over a power recycling system by using dual recycling with a cavity of finesse 150 as the signal recycling mirror. Figure 9 shows the performance for broadband systems with no frequency offset, figure 10 assumes tuning of the 3 km, 30 bounce interferometer to a centre frequency of 150 Hz. Remember that the normalised misalignment angle is  $\theta/\theta_c = \theta\pi w/\sqrt{2}\lambda$ . These two figures should be compared to

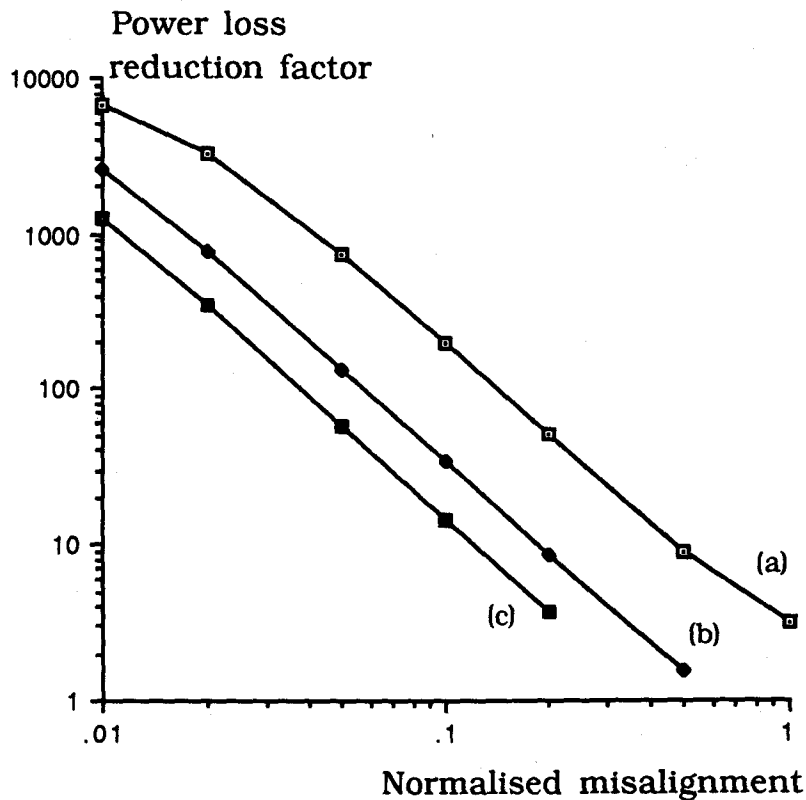

Figure 9: *The improvement of power loss in broadband dual recycling with a compound mirror: (a)  $T_{30}^2 = 1$ ; (b)  $T_{30}^2 = .5$ ; (c)  $T_{30}^2 = .25$ .*

figures 4 and 5 — but notice the compression of the scale. It is clear that significantly better performance is obtained with the cavity as the signal recycling mirror, especially in broadband arrangements.

Some values of the fractional power loss as a function of misalignment angle, for various different optical arrangements, are plotted in figure 11. This both quantifies the required alignment accuracy in power recycling and shows how the different types of dual recycling ease this requirement. Equivalent plots for other types of distortion will not differ greatly. It can be seen, for example, that if the fractional power loss resulting from distortion is 1% with no signal recycling, the corresponding loss with a cavity as the output mirror, set to perfectly transmit the fundamental mode, would be less than  $10^{-4}$ . Looking back to figure 3, we can see that this would increase the signal to noise ratio for a detector with losses  $NA^2 \sim 10^{-3}$  by a factor of more than 5. Somewhat smaller, but still significant, improvements will be achieved with bet-

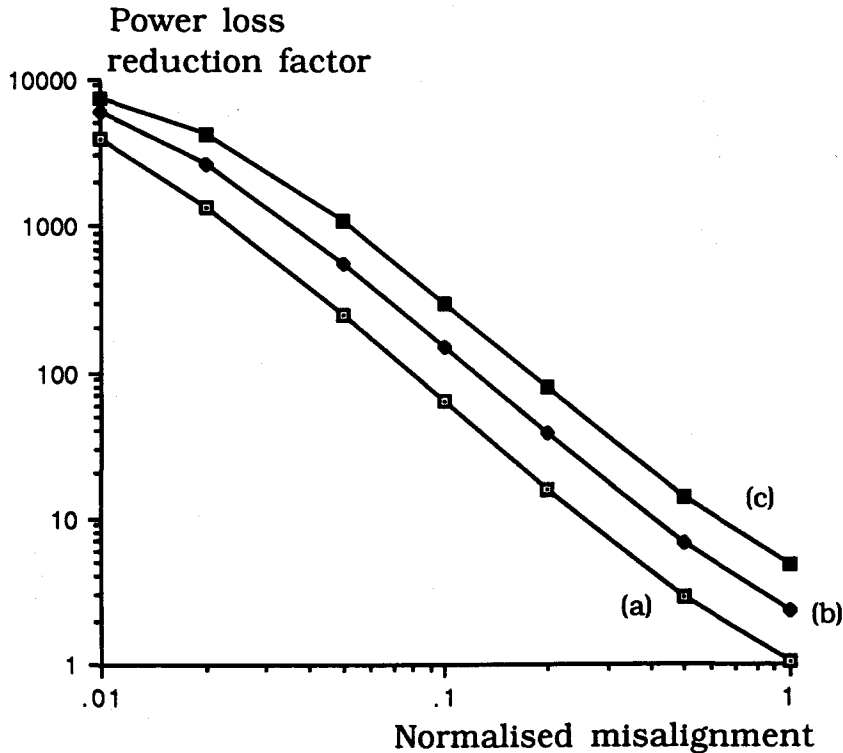

Figure 10: *The improvement of power loss in narrowband dual recycling with a compound mirror: (a)  $T_{30}^2 = .25$ ; (b)  $T_{30}^2 = .1$ ; (c)  $T_{30}^2 = .05$ .*

ter initial contrasts. The tolerable distortion is increased by an order of magnitude. Yet this improvement in performance is achieved without any restriction of the frequency response of the detector. If dual recycling with a compound mirror can be implemented in practice, it is evident that it may greatly improve the performance of laser-interferometric gravitational-wave detectors.

The fundamental mode of the output cavity would normally be matched to the original, undistorted fundamental mode of the interferometer. The coupling of the distorted mode to the cavity would then be just the same as the coupling of the incident laser beam. So as long as the initial distortion is small (spatial deviation  $\ll \lambda/2$  in a beam radius), this coupling will be high, the signal will be enhanced and the frequency response unaffected.

The requirements for the properties of the output cavity do not seem severe. We have seen that a finesse of about 150 is perfectly adequate which, with good quality mirrors should not introduce significant extra loss. The cavity must be non-confocal, but there is no particular requirement on its length apart from ease of mode-matching.

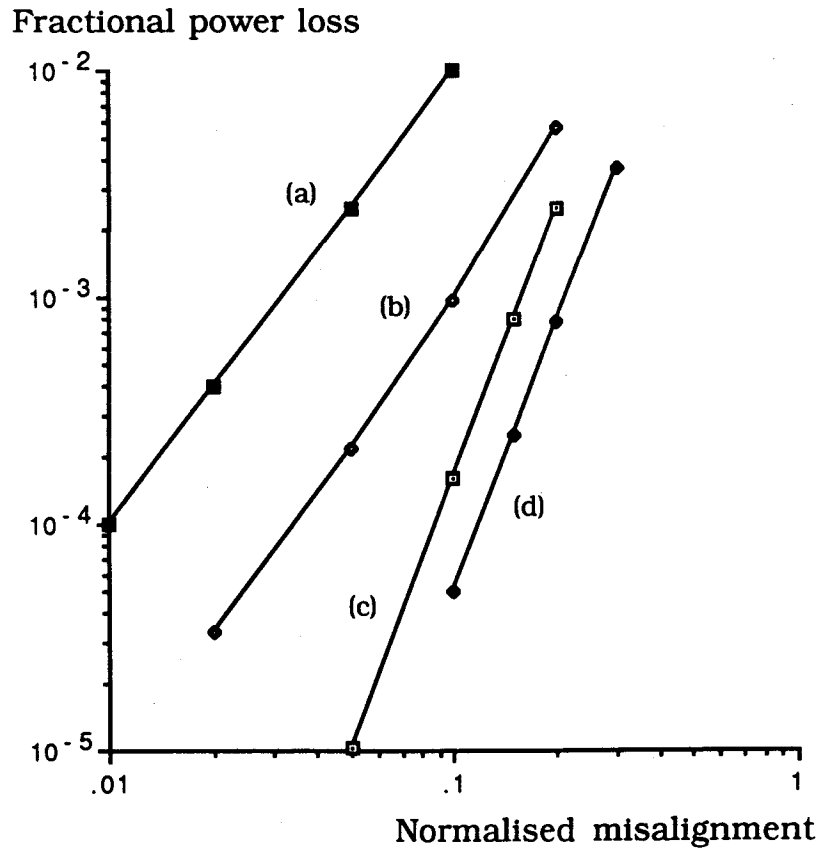

Figure 11: Power loss due to misalignment for several optical systems: (a) standard recycling; (b) broadband dual recycling with  $T_3^2 = .25$ ; (c) dual recycling using a compound mirror with  $T_{30}^2 = .25$ , tuned to 150Hz; (d) dual recycling using a compound mirror with  $T_{30}^2 = 0$ . Angles are in units of  $\theta_c$ .

With a length of  $\sim 1$  m, the linewidth would be  $\sim 1$  MHz, much larger than the frequency of the gravitational waves: this means that the two gravitational-wave-induced sidebands will experience the same phase shift on reflection off this cavity, so the frequency response of the system will be the same as if the cavity was a simple mirror of the same reflectivity. The most difficult practical problem associated with using a cavity as the signal recycling mirror currently seems to be the extra complication of controlling the cavity. Its length must be adjusted to give the correct reflectivity (hence bandwidth), while its overall position determines the gravitational-wave frequency that is resonant. These two adjustments are coupled, for a change in cavity length will alter the phase shift on reflection off the cavity, changing the resonant frequency of the signal recycling cavity. We will not discuss details of the control systems here. However, it

will probably be necessary to sense the state of resonance of the signal recycling cavity with light containing two frequencies: one which resonates in a similar way to a signal sideband, giving information on the tuning of the system; and one which resonates mainly in the output cavity, giving information on the bandwidth.

The use of a geometry-selective signal recycling mirror may have some other advantages. The amount of light that is scattered off a mirror onto the walls of the vacuum pipe and back to hit the final photodiode should be considerably reduced. Any worries about noise generated by this scattered light [16] should be correspondingly less serious. Furthermore, the improvement in fringe contrast in a non-dissipative fashion may increase the factor by which the use of squeezed light can improve the sensitivity [17].

It is clear that dual recycling with a compound signal-recycling mirror has the potential to give very good performance. In view of the possible importance of this system, it is to be hoped that a direct experimental test of the predictions will be made in the not too distant future. Tests using a numerical simulation are underway at ANU, Canberra, and should produce results quite soon.

### **3.6 Conclusion**

We have evaluated the mirror alignment and figure required if the full sensitivity of interferometric gravitational-wave detectors is to be attained. It is clear that in power recycling it is very easy for distortions of the beam to allow light to leak out of the interferometer, reducing the power build up, increasing the light hitting the photodetector and so limiting the sensitivity. The requirements on mirror figure and alignment are severe in this case. Lowering the gravitational wave frequency for which the detector is optimised helps somewhat. Mirror figure requirements are relaxed substantially if the dual recycling system is tuned or narrowbanded. Truly narrowband detectors are tolerant of distortion. In addition, we have seen that there is a solution which allows greater distortion without reducing the detector bandwidth—the use of a non-confocal optical cavity as the signal recycling mirror. This should relax the requirements on mirror alignment and figure by an order of magnitude. The result may well be significantly better gravitational-wave sensitivity, perhaps by a factor as high as 5. Indeed, since the use of a cavity as the signal recycling mirror allows the sensitivity-bandwidth combination of the detector, as well as its tuning, to be varied without physically changing any components, this arrangement should lead to a gravitational-wave detector which is both sensitive and very flexible in its operation.

### 3.6.1 Acknowledgements

We would like to gratefully acknowledge the support of the University of Glasgow, the Science and Engineering Research Council and (for BJM) the Royal Society.

## References

- [1] R. E. Vogt, R. W. P. Drever, K. S. Thorne, F. J. Raab and R. Weiss, *LIGO proposal*, (Caltech, 1989)
- [2] J. Hough, B. J. Meers, G. P. Newton, N. A. Robertson, H. Ward, G. Leuchs, T. M. Niebauer, A. Rüdiger, R. Schilling, L. Schnupp, H. Walther, W. Winkler, B. F. Schutz, J. Ehlers, P. Kafka, G. Schäfer, M. W. Hamilton, I. Schütz, H. Welling, J. R. J. Bennet, I. F. Corbett, B. W. H. Edwards, R. J. S. Greenhalgh and V. Kose, *Proposal for a Joint German-British Interferometric Gravitational-Wave Detector*, Report **MPQ 147**, (MPQ, Garching, 1989)
- [3] A. Giazotto et al, *The VIRGO Project*, (INFN, Pisa, 1989)
- [4] H.-A. Bachor, D. G. Blair, D. McClelland and R. J. Sandeman, *AIGO proposal*, (ANU, Canberra, 1989)
- [5] K. S. Thorne, in *300 Years of Gravitation*, edited by S. W. Hawking and W. Israel (Cambridge University Press, Cambridge, 1987).
- [6] R. W. P. Drever, in *Gravitational Radiation*, edited by N. Deruelle and T. Piran (North-Holland, Amsterdam, 1983)
- [7] B. J. Meers, *Phys. Rev. D* **38**, 2317 (1988)
- [8] B. J. Meers, *Phys. Lett. A* **142**, 465 (1989)
- [9] R. W. P. Drever, *personal communication* (1983)
- [10] C. N. Man, D. Shoemaker, M. Pham Tu and D. Dewey, *Phys. Lett. A* **148**, 8 (1990)
- [11] R. Schilling, *personal communication* (1986)
- [12] G. D. Boyd and J. P. Gordon, *Bell Syst. Tech. J.* **40**, 489 (1961)
- [13] J.-Y. Vinet, B. J. Meers, C. N. Man and A. Brillet, *Phys. Rev. D* **38**, 433 (1988)

- [14] L. Ronchi, in *Laser Handbook I*, edited by F. T. Arecchi and E. O. Schulz-Dubois (North-Holland, Amsterdam, 1972)
- [15] K. A. Strain and B. J. Meers, paper submitted to *Phys. Rev. Lett.*
- [16] K. S. Thorne, *Caltech Golderod Preprint* GRP-200 (1989)
- [17] J. Gea-Banacloche and G. Leuchs, *J. Mod. Opt.* **36**, 1277 (1989)