

Preliminary Optical Fiber Stabilization for AdvLIGO Pre-Lock Acquisition System

Jaclyn R. Sanders

Mentors: Dick Gustafson, Paul Schwinberg, Daniel Sigg

Abstract

Advanced LIGO requires a seismic platform interferometer to reduce the relative mirror velocity in the long arm cavities. An arm cavity can be locked independently by injecting laser light through the end mirrors. This requires the transfer of an optical wavelength standard to the end stations using fibers. A fiber stabilization system is required to compensate for thermal drifts and acoustic excitations of the fibers. Acousto-optic modulators (AOMs) are used to add frequency shifts to the outgoing and return light. A feed-forward system then alters the input light to compensate for the fiber noise.

1 Introduction: Cavity Locking and the Need for a Phase Standard

Key to the function of the LIGO interferometer is the system that brings the arms into "lock". The design of the interferometer is such that the laser light travels into a 4 km long Fabry-Perot resonant cavity rather than a straight 4 km mirror reflection. The effect of using these resonant cavities is to simulate an interferometer with a baseline on the order of hundreds of kilometers. In order for the interferometer to work, both arm cavities must be in resonance, and these cavities must be in resonance with the entire interferometer. In iLIGO and eLIGO, the interferometer is brought into lock by letting the optics swing freely, then catching them with electromagnets and holding them in resonance. Although this works in practice, this system introduces undesirable amounts of electronic noise into the interferometer, and hence it is slated to be replaced with an alternative system for cavity locking.

The system of choice is a frequency-shifted Pound-Drever-Hall system. A key difference between the current LIGO interferometer and the setup required for this system is that the interferometer cavities are brought into resonance with the assistance of a secondary signal from the other end of the cavity. This signal must be in phase with the primary signal, and to do this, the secondary laser is phase-locked to the primary laser. This requires a phase standard to be transmitted from the primary to the

secondary laser over a distance of 4 km, and due to the setup of the optics, the phase standard cannot be injected through the vacuum.

The best alternative to transmission to the vacuum that is available is optical fibers. These have been used for transmitting data signals for decades, and as such there is an existing network at both LHO and LLO that can be used for transmitting light from the initial laser to the end-station where it can be phase-locked to the secondary laser. However, the phase information in the laser light is easily disturbed by vibrations in the fiber, and after traveling 4 km the phase information will be completely lost. Hence, in order to transmit this information, a scheme must be developed to stabilize the light as it passes through the fiber. Another complication involved in using the existing fiber network is that the optical fibers are optimized for transmitting light with a wavelength of 1310 nm, while LIGO's lasers operate at 1064 nm. This results in significant power loss that makes transmitting the phase standard more difficult.

One possibility is to eliminate vibrations and other noise sources within the fiber. However, this would be nearly impossible, as it would require completely isolating four kilometers of fiber from acoustic and seismic noise sources. The National Institute of Standards and Technology devised a functional scheme for optical stabilization and published a paper discussing it in 2003. In their work, NIST was using a similar philosophy as the desired result for AdvLIGO- injecting frequency references into an existing communications fiber network. Their study also concerned the injection of a 1064 nm carrying frequency into fibers optimized for 1310 nm. In short, the NIST study proves that the levels of stability needed for the AdvLIGO phase standard is possible with the existing fiber networks at the observatories.

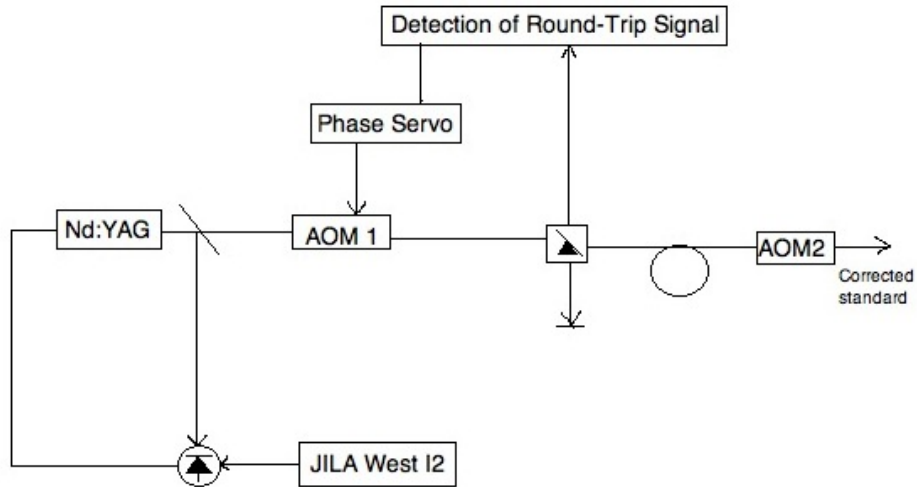

Figure 1: A reproduction of the figure from the NIST study.

In section four of the 2003 paper, the NIST group describes their scheme for the active cancellation of fiber-induced phase noise. The two key elements are the *acousto-optic modulators* (AOMs) and the feed-forward electronics, or *phase servo*. The acousto-optic modulators shift the frequency of the light, and the servo analyses the beat between the frequencies of the incoming and outgoing light. Light from the laser is shifted upwards a constant amount by the first AOM, then transmitted through the fiber. Then it is passed through the second AOM, which removes the constant upshift from the light, and passed through again, shifting the light downwards. This light is transmitted back through the optical fiber and into the phase servo, where it is mixed with the input light to form a beat signal. This beat signal is then divided by two and fed into the first AOM, where it adds an error signal onto the constant signal already on the AOM. The end result is that the light going into the fiber from the first AOM is shifted so that the noise in the optical fiber removes the error signal, leaving a clean signal at the output.

With this NIST work as a guide, the transmission of a stable optical signal through fiber optics is a viable solution to the need for phase locking. The focus of this summer's work on optical fiber stabilization was recreating the NIST system at the LIGO Hanford Observatory optics lab. The construction of and characterization of this system was merely begun over my ten-week research appointment, and the remainder paper details the work completed, the photonic principles behind the construction, and problems uncovered during the summer's work.

2 Design Considerations

The main difference between the optical system constructed at LHO and the NIST system is that the LHO system, being a prototype, can have negligible spatial separation between both ends of the fiber. In other words, it was determined that, rather than have two optical tables four kilometers apart, an existing fiber connection loop between a part of the interferometer two kilometers away would be used, allowing for both ends of a four-kilometer fiber to rest on the same optical table. The ability to have both ends of the fiber on one table allows for analyzing the input and output signals simultaneously to determine the effectiveness of the stabilization system.

The desire to have an analysis signal requires slight changes to the NIST design.

In this basic function diagram, the main difference from the NIST design is the addition of the beamsplitters and the second photodiode. This photodiode will allow for the signals at the laser and at the output to be directly compared.

2.1 Laser

LIGO's main laser is currently a 35W neodymium-doped yttrium-aluminium-garnet (Nd:YAG) non-planar ring oscillator (NPRO), with a wavelength of 1064 nm. To simulate the light emitted from this laser, a smaller NPRO

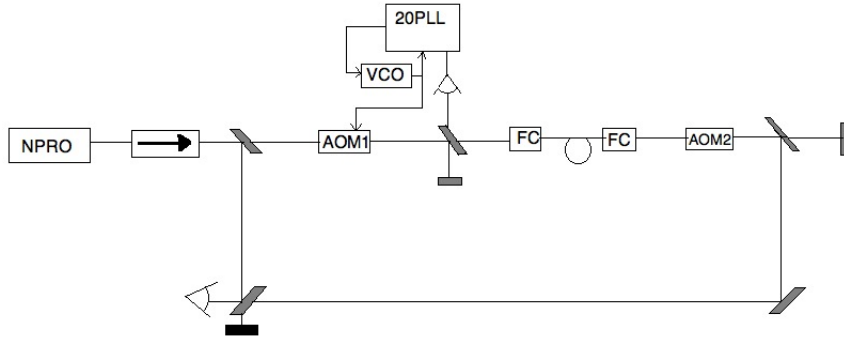

Figure 2: A zero-order function diagram.

with a maximum power of 1W was used for this project. The advantage of this type of laser is that it suppresses standing-wave patterns in the laser cavity and produces a stable single-frequency beam. If it was not a single-frequency beam, the stabilization system would have to work against the instability of the laser as well as the noise in the optical fibers.

2.2 Optical Fibers

Optical fibers are generally optimized to a particular wavelength. Unfortunately, communication standard wavelengths are 1310 nm and 1540 nm, meaning that there will be high losses over the course of the transmission. Over the course of the construction and analysis, one-way power transmissions of 50% were typical over test lengths of fiber, and 30% transmission is expected over the 4 km fiber.

Another quality of optical fibers is whether they are single or multi-mode fibers. Multi-mode fibers are wider and allow for more power to be transmitted. However, they also have unnecessary modes of propagation that induce more noise in the output signal. Single mode fibers have a narrower transmission medium, and only allow for one mode to pass through. This results in the cleaner signal needed for this application with a higher requirement for precision- the beam must be focused so that it travels through a $10 \mu\text{m}$ entrance aperture for optimal transmission.

For the portion of the construction detailed in this paper, a 10 m long test fiber was used. In later testing and in the final application, the laser will be injected into 4 km of communications fiber currently installed in the LIGO observatory.

2.3 Acousto-Optic Modulators

The two acousto-optic modulators are key to the function of the system. AOMs are photonic devices; that is to say, their function relies on both

optical and electronic principles. At the core of an AOM is a crystal that is selectively sensitive to vibrations. This crystal is driven such that acoustic waves travel through it, producing acoustic energy that can be expressed as a stream of *phonons*, small particles of sound energy, which collide with the photons passing through the crystal. The phonons traveling through the crystal collide with the photons and shift their energy, diffracting them in the process. These in turn carry the frequency shift. AOMs produce zero-order, first-order, and higher-order beams. The zero order beam is not deflected and has no frequency shift. The first-order beam is deflected by θ and is shifted by ω . Nth-order beams are deflected by $n\theta$ and are shifted by $n\omega$.

In this system, two ISOMET 1205C-843 AOMs were used. This choice of AOM set the frequency to be used at $\omega = 80\text{MHz}$.

2.4 RF Photodiodes

Two RF, or radio-frequency, photodiodes were used for detecting the light signals in the system. The particular model used, New Focus 1811, have both DC and AC outputs. The DC output measures the amount of power incident on the photodiode aperture, while the AC output only records beat signals, or differences between the frequencies of different beams of light incident on the photodiode. This is ideal for this application, as we are comparing shifted and unshifted beams of light at different frequencies and using these beat signals to control the electronics.

3 Construction

3.1 Optics

A $\lambda/2$ wave retarder is used for initial power control. The orientation of the wave retarder with regards to the polarization of the input beam determines how much of the laser light passes through. Thus, one was placed at the beginning of the system in a rotating mount so it could be turned in relation to the polarization to control the amount of light that passed through it.

Wave retarders also are a key component of the *optical isolator*, also known as an optical diode. The purpose of this arrangement is to drastically reduce the amount of light passing through the diode in one direction. Since the system involves reflecting light so that beams are traveling in two directions through the same components, an optical diode was installed to protect the laser from overload due to back reflection. The diode installed in this system incorporates a wave retarder, a Brewster angle polarizer, a Faraday rotator, another Brewster angle polarizer, and another wave retarder in series. The effect of this is to allow light to pass through in one direction, but to rotate the polarization of the returning light such that no light can pass through the first wave retarder.

The fiber couplers used for this project, New Focus 9091, have 5 degrees of freedom built in to the coupler itself: x , y , and z translation, and θ_x and θ_y rotation. Since the single-mode fibers used for the system

have apertures with diameter on the order of $10\ \mu\text{m}$, two planar mirrors were used to aim the beam into the fiber coupler before using the aligner's degrees of freedom.

One factor that must be avoided in aligning the fiber is the possibility of cladding modes, where the laser light travels not through the central single-mode fiber but through the outer coating, or cladding, of the fiber. In order to ensure proper alignment, the free end of the fiber was placed in front of an infrared-sensitive CCD camera. Cladding modes can be seen on the screen as dumbbell-shaped spots of light, while the dominant central mode is more circular.



Figure 3: An image of IR light emitted from the fiber.

Convex lenses were chosen from a lens kit to refocus and shape the beam. Note the placement of lenses in front of the photodiodes and the AOMs. This is to narrow the beam for maximum transmission through the small apertures of the AOMs and the photodiodes. At points, a beam camera was used to measure the width of the beam, and this data was used to guide the choice of lens.

Recall from the above discussion that if a spherical mirror is placed in the path of a Gaussian beam such that the curvature of the beam is equal to the curvature of the mirror, the beam will reflect back along its path. Recall also that nine degrees of freedom were available for placing the beam into the first fiber coupler. A spherical mirror was used at the end of the system to propagate the return beam, and due to this property of Gaussian beams, it reflects the beam back into the fiber.

The overall layout of the system was designed to accommodate recombining shifted and unshifted beams. Note the first optic encountered after leaving the laser, a 98% reflective partially silvered mirror. The output

leg was placed so that the 2% transmitted light could be recombined with the output light for viewing at the analysis photodiode.

Similarly, this beamsplitter was placed so that the beam going into the fiber and coming out of the fiber could easily be combined at the control photodiode. These RF photodiodes, as discussed above, can either measure beat signals or DC power. Placing these photodiodes so that two different signals can fall on them with minimal optical loss is essential to the measurement of beat signals.

3.2 Electronics

In the LIGO version of the system, the electronics are not a true servo. Servo implies a feedback system, while this version uses a feed-forward system; the system detects changes and feeds a response into the input, while a servo would feedback to keep the system at a steady point. Although the feed-forward approach is theoretically less stable, as it will apply changes whether or not the system is trending towards instability, using a feed-forward system is more desirable in this case because of the distances involved.

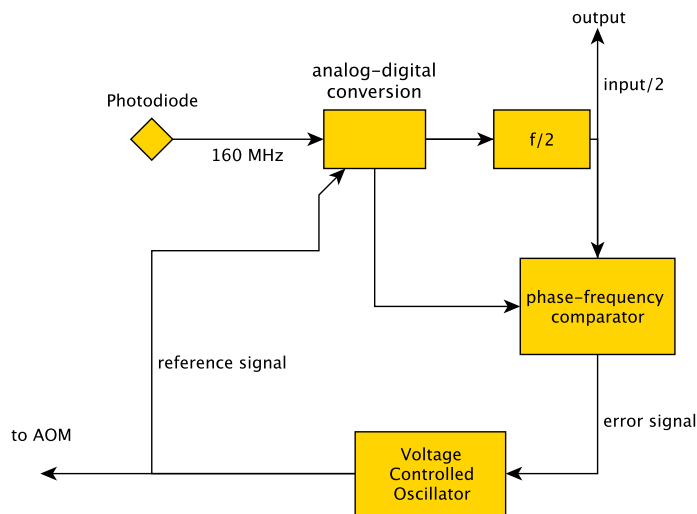

Figure 4: Block diagram of the 2Ω phase-locked loop. A circuit diagram is included as Appendix ii.

A previous summer student had developed a phase-locked loop circuit that coincidentally performs the exact task needed for our feed-forward system.

The board, called a 2Ω Phase-Locked Loop, functions by comparing the beat signal at the control photodiode, dividing it by two, then com-

paring it to the instantaneous driving signal of AOM1. It then outputs the difference in the frequency to the signal generator driving AOM1. This board should lock to a state with no difference between the input frequency and the signal generator. After construction, we were able to see the beat signal and its lock.

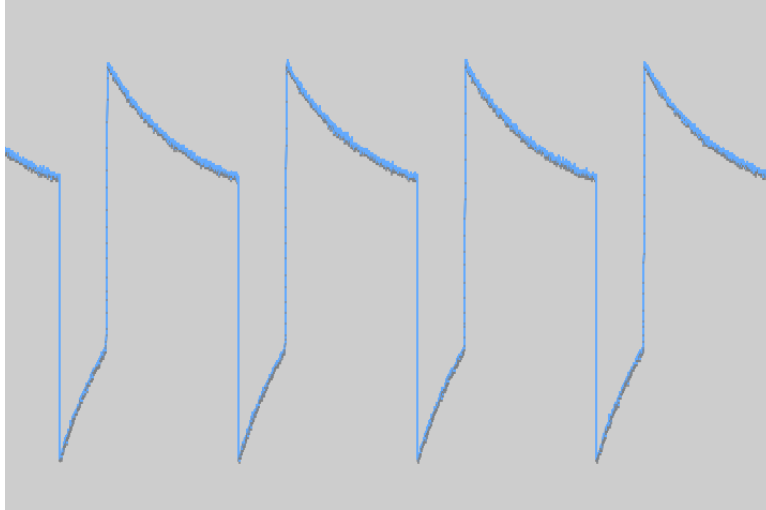

Figure 5: Oscilloscope beat between signal at 160.0001 MHz and 80 MHz without 2Ω PLL locked.

Pertinent characteristics of the board were also measured. It was determined that the board has appropriate voltage response down to an input of 50 mV, bringing us to the conclusion that we need at least 50 mV of signal. This led to the use of RF amplifiers, devices that take radio-frequency signals, such as the one going into the board, and increase their power.

To drive the AOMs, laboratory signal generators were used. Two different models were used: one HP ESG1000A, and one IFR 2023A. These two models have the ability to emit and exchange a frequency standard, so that they both produce uniform waveforms. The HP model was used to provide a constant frequency signal to AOM2, while the IFR model was used for the feed-forward system and the driving of AOM1.

4 Encountered Problems

Immediately upon completion of assembly, it was noted that the system was not working properly. With the light from the fiber blocked, an 80 MHz peak was observed at the analysis photodiode.

Recall that RF photodiodes either measure DC power or AC beats. This plot implies that there is a beat at 80 MHz. However, no light was incident on the photodiode at the time. This is a clear sign of coupling between the photodiode and the signal generators.

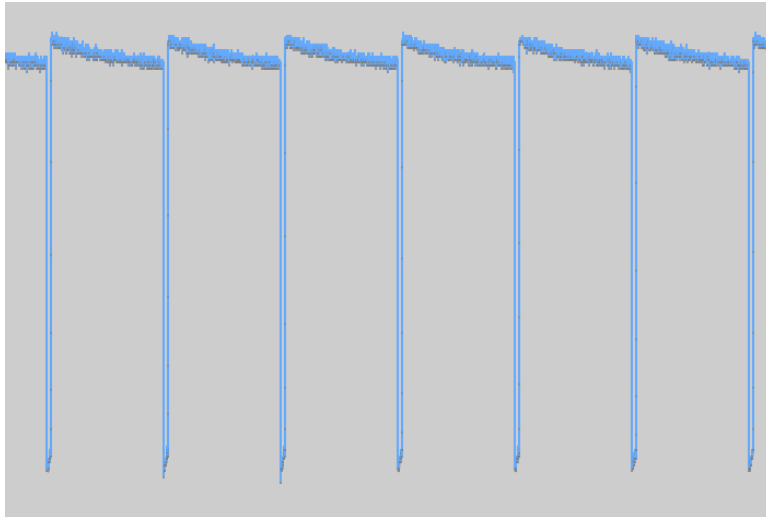

Figure 6: Oscilloscope beat between signal at 160.0001 MHz and 80 MHz with 2Ω PLL locked.

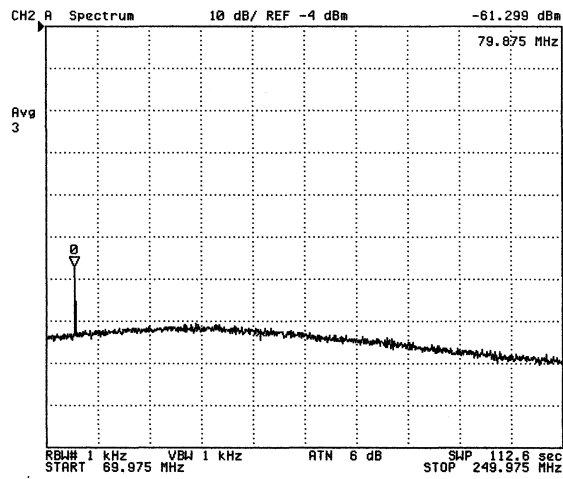

Figure 7: 80 MHz peak at analysis photodiode.

Noise contamination such as this beat signal was prevalent throughout the system.

If these plots were from the same setup, it would not be a problem. However, as the labels show, the top figure was only the photodiode readout from the light passing through the fiber, while the bottom figure had both the fiber output and the initial laser sample incident on it. No change in peak height was observable. Clearly, the noise within the fiber output

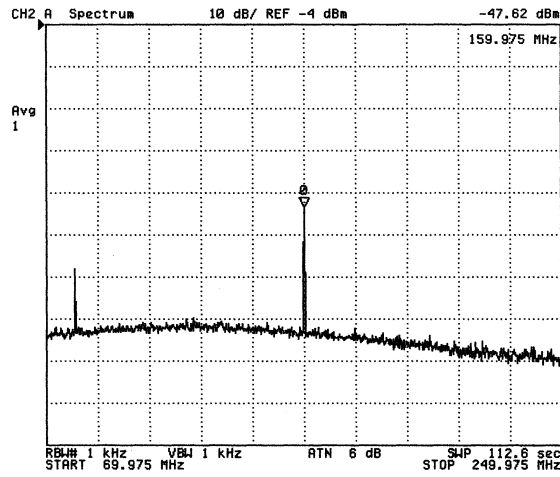

Figure 8: Analysis photodiode with system light.

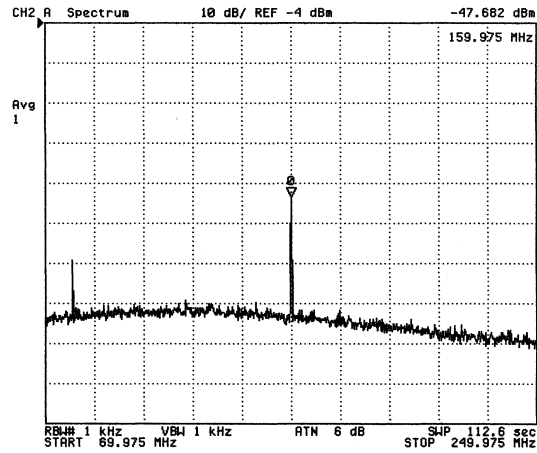

Figure 9: Analysis photodiode with system and laser light.

signal overwhelmed the beat against the 0 MHz laser sample. With the signal at the same frequency as the noise, the ability of the system to clean any induced fiber noise could not be measured.

Compounding this was back reflection from the surfaces in the fiber coupler. After some work, it was determined that the reflection came from the end of the optical fiber itself. What this means for the physical system is that there is always reflection of the input signal mixing with the output signal at the fiber. This results in exaggerated interference at the control photodiode that could not be cleaned.

All of the contamination present in the system resulted in the board not being able to lock onto the 160 MHz signal at the control photodiode. This meant that the feed-forward system could not begin to work, hence, no fiber stabilization could be observed.

5 System Revisions

Analysis of noise signals before and after the AOMs suggested that interference due to reflection from the AOM casing and clipping of laser light around the edges of the aperture could be a factor in the self-interference signals observed. The observed beats at 80 MHz and 160 MHz would be consistent with a mixture of zero, first, and second-order frequencies within a single beam. All of this implied that greater attention should be paid to the positioning of the beam as it entered and exited the AOMs to prevent mixing of frequencies of different orders.

Aside from improving the beam shaping with different lenses, the AOM situation was improved by increasing the power to the AOMs. In the first system, about a half a watt of power was supplied to each AOM. In the revision, RF amplifiers were placed in series with the signal generators and AOMs, increasing the power to each AOM. The increased power led to clearer beams of each mode and allowed more power to be allocated to the first-order mode. While changing the AOM power, it was noted that the second AOM was in the wrong orientation. Switching this angle also helped clean the signal. A CAD drawing of the system may be viewed as Appendix i.

The physical arrangement of the AOMs and their resulting beams was not the only issue to be addressed. As noted above, the signal generators were coupling into the RF photodiodes. By turning the signal generators on and off, it was determined that the HP generator was exhibiting coupling behavior, while the IFR was not. A second IFR generator was procured and installed in place of the HP generator, which reduced the noise coupling.

Also, it was noted that there was significant broadcasting, or leakage, of RF signals from poorly clad cables and connections. Each cable connection in the system was checked, and if it was found that the cable was compromised, it was replaced. For connections where broadcasting could not be eliminated, attenuators were installed to reduce the effect of said broadcasting.

Another problem noted was that the board was not tuned to 160 MHz. In order to fix this, some electronics had to be replaced. One resistor was increased from 49.9Ω to 210Ω , and the inductor in the tuning RLC circuit was changed to a heavier inductor. This allowed the circuit to be re-tuned to 160 MHz. Despite all of these changes, the system had an inherent instability that made locking the board with the system nearly impossible. The board was observed to lock for a matter of microseconds before falling out of lock.

In its revised form, however, the system did not exhibit the self-interference problem observed at the analysis photodiode in the initial system. This meant that the effect of induced fiber noise on the system

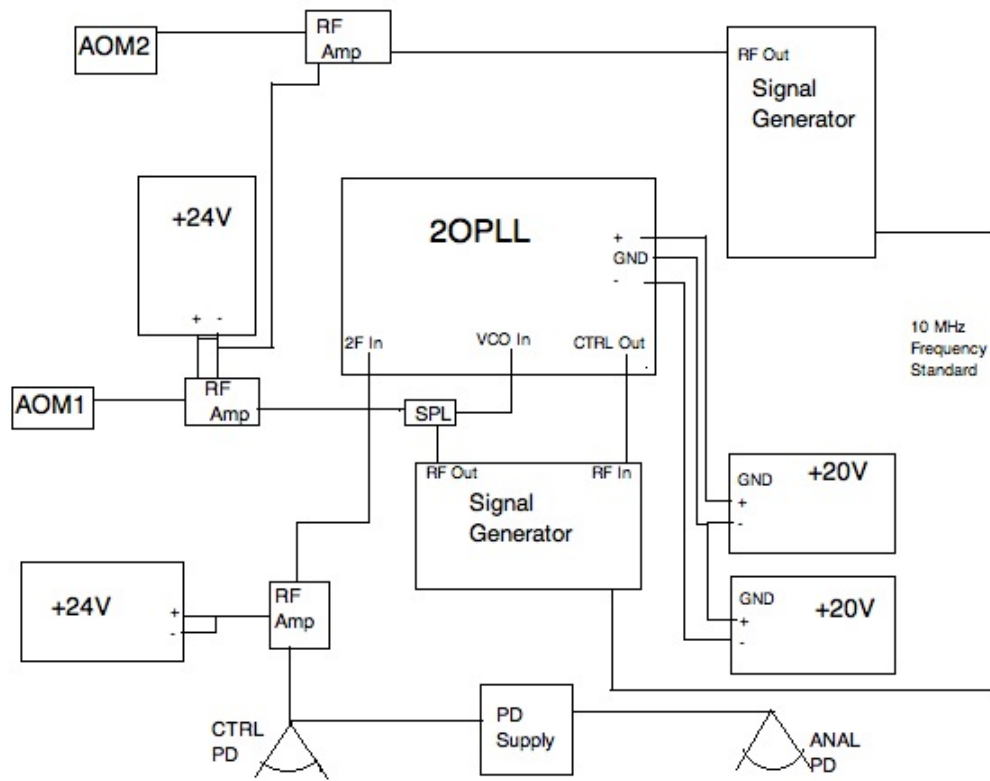

Figure 10: Functional diagram of the system electronics.

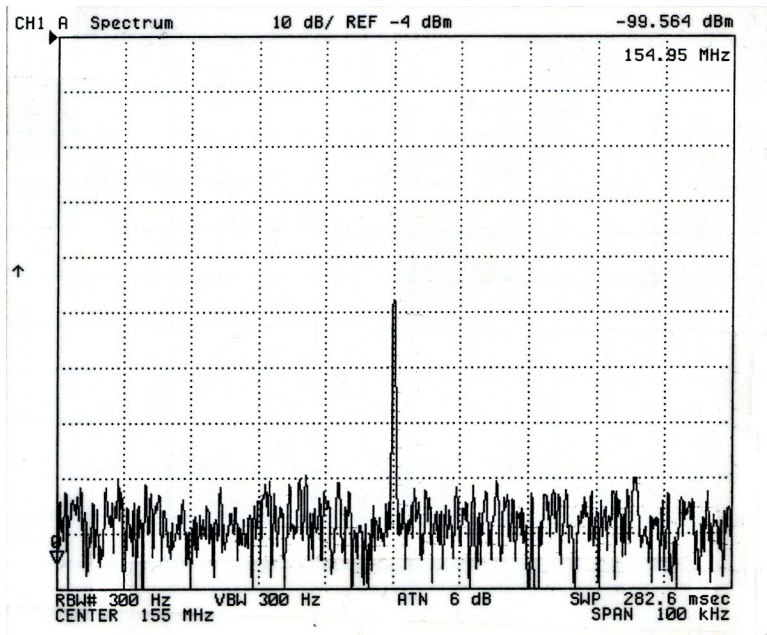

Figure 11: Signal through the test fiber without noise injection..

could be observed over the test fiber. In this aspect the system performed admirably, with clearly visible noise effects at the analysis photodiode.

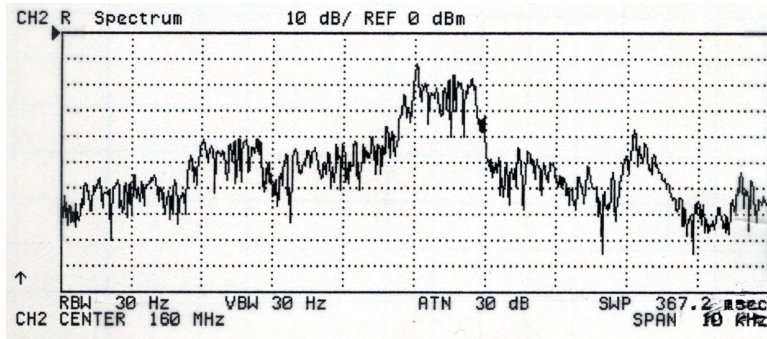

Figure 12: An example of the effect of random noise injection.

This is the steady signal on the analysis photodiode after passing through the system. Here and in the subsequent figures in this section, the fiber output and initial laser light are both incident on the photodiode.

A random noise injection was performed by manually shaking the bundle of optical fiber.

Here, a piezoelectric buzzer was set adjacent to the fiber, driven by a simple signal generator at 3 kHz with voltage 1 V_{pp}. Note the 3 kHz

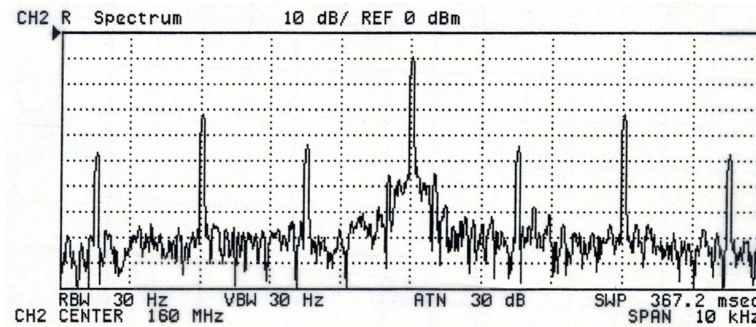

Figure 13: The characteristic comb noise pattern from a 3 kHz noise source.

harmonics on either side of the central peak.

6 Conclusion

After my departure from LIGO, other members of the group picked up the fiber stabilization project. The board itself was the first order of investigation. After checking for cold solder joints in the components and re-tuning the board, there has been some preliminary success in locking the board. According to Dick Gustafson, locks on the order of ten seconds have been observed.

Other ideas proposed for cleaning the signals are realigning and checking polarization of the interfering beams at the RF photodiodes. It is possible that interference fringes are causing additional noise at these photodiodes. Another idea up for implementation is the installation of fiber leads. These short fibers have apertures with an angled cut on one end and a port for inserting another fiber on the other end. The angled cut would drastically reduce the effects of back reflection, and having ports would allow for easy swapping of test fibers and the 4 km fiber for full-scale testing.

Although the question of applying optical fiber stabilization is still not completely answered, what is known is that it is possible to lock such a system in laboratory conditions at the LHO. Therefore, the Pound-Drever-Hall pre-lock acquisition system is still viable, and will likely be implemented for AdvLIGO with help of the completed fiber stabilization system.