



LIGO Laboratory / LIGO Scientific Collaboration

LIGO-T040096-02-R

ADVANCED LIGO

20th July 2004

Upper-Intermediate Mass for ETM Controls Prototype Quad Pendulum
Suspension

Product Design Specification

M. Perreur-Lloyd¹, N.A. Robertson^{1,2}, Calum Torrie³

1 Institute for Gravitational Research, University of Glasgow

2. Stanford University

3. California Institute of Technology

Distribution of this document:
LIGO Science Collaboration

This is an internal working note
of the LIGO Project.

California Institute of Technology
LIGO Project – MS 18-34
1200 E. California Blvd.
Pasadena, CA 91125
Phone (626) 395-2129
Fax (626) 304-9834
E-mail: info@ligo.caltech.edu

LIGO Hanford Observatory
P.O. Box 1970
Mail Stop S9-02
Richland WA 99352
Phone 509-372-8106
Fax 509-372-8137

**Institute for Gravitational
Research**
University of Glasgow
Kelvin Building
Glasgow G12 8QQ
Phone: +44 (0)141 330 3340
Fax: +44 (0)141 330 6833
Web: www.physics.gla.ac.uk/gwg

Massachusetts Institute of Technology
LIGO Project – NW17-161
175 Albany St
Cambridge, MA 02139
Phone (617) 253-4824
Fax (617) 253-7014
E-mail: info@ligo.mit.edu

LIGO Livingston Observatory
P.O. Box 940
Livingston, LA 70754
Phone 225-686-3100
Fax 225-686-7189

<http://www.ligo.caltech.edu/>

Upper-Intermediate Mass for the ETM Controls Prototype Quad Pendulum Suspension

PRODUCT DESIGN SPECIFICATION

NOTE: This is a working document. Please consult the authors for the latest specifications for the Upper-Intermediate Mass.

Revision 00: First draft of the Upper-Intermediate Mass PDS

Revision 01: Alterations to Section 4 – Table inserted of geometric and mass values for U-I mass; Section 5 - Additional/revised renderings of the latest mass design; Additional information on global actuators; Additional information on consideration of future interfacing sub-assemblies; Attachment of Appendix 1 – Discussion of changes to blade/suspended mass wire clamp; Addition of Appendix 2 – Introduction to Analysis of mass bending.

Revision 02: Slight reformatting – addition of revision notes.

1. INTRODUCTION

This product design specification for the Upper-Intermediate Mass (U-I Mass) is written to ensure that no design factors are ignored or omitted during the development of the design. The first draft of this document contains all known specifications at the time of writing. The PDS will however evolve during the design process and, on completion of the physical assembly, match the characteristics of the upper-intermediate mass.

The U-I Mass for a quadruple pendulum is constructed from what looks like, two triple pendulum upper masses (one inverted) joined together one above the other to form something resembling a sandwich. The ‘filling’ within the sandwich consists of two cantilever blades (that interface with the wires that suspend the penultimate mass) and some clamping fixtures for the wire coming from the middle blades. Alignment at the U-I stage is done via four coil-magnet actuator assemblies located between the main and reaction U-I masses.

The specifications for the U-I Mass are primarily set by the output values from the MATLAB Quadruple Suspension model for the ETM. However, other factors determine the final design of the mass and alter its make-up from the ideal model MATLAB produces. These include ease of assembly, installation and interference of parts.

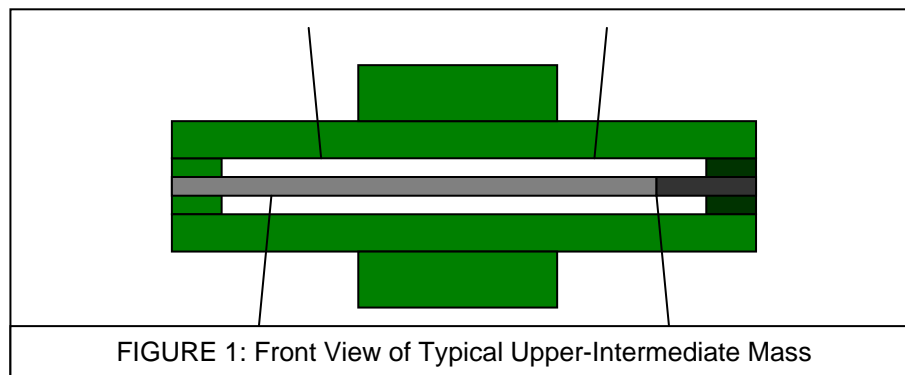

FIGURE 1: Front View of Typical Upper-Intermediate Mass

2. PAST QUADRUPLE PENDULUM UPPER-INTERMEDIATE MASS MODELS

Experience and techniques from the design, manufacture and installation of the MIT Quad model and recent triple suspensions should be considered thoroughly during the design of the U-I Mass.

In the build up to developing a full working ETM Quad Controls Prototype Suspension, a layout design was drawn up in August 2003. This model should be referred to as the starting point for any further conceptual and detailed design.

3. MATLAB QUADRUPLE SUSPENSION MODEL

The MATLAB Model is a mathematical model that gives specifications for a suspension design based upon the desired requirements for isolation and sensitivity. These requirements and output specifications are shown in document T010103¹ (the numbers have since been updated in document T040028²).

All target parameters for geometry, mass and moment of inertia given by the MATLAB model will change as the CAD solid model of the U-I Mass advances. The target parameters are very much the ‘best’ theoretically but not the ‘optimum’ in terms of producing a design for ease of assembly, interfacing or use.

The design of the mass should be seen as an iterative process where any changes or additions to the solid model, and therefore changes to the mass and moments of inertia, will be passed to Norna Robertson to run through the MATLAB model. By so doing, a complex Upper-Intermediate Mass model can be designed that has parameters that are within the allowable tolerance of all targets.

¹ T010103; Advanced LIGO Suspension System Conceptual Design; N.A. Robertson for the GEO Suspension Team + LIGO Suspension Team

² T040028; Investigation of Wire Lengths in Advanced LIGO Quadruple Pendulum Design for ETM/ITM; N.A.Robertson

4. PERFORMANCE

The dynamic performance of the U-I Mass is dictated by the parameter limits given in the MATLAB Quad Suspension Model. Below are quoted some of the numbers from the initial MATLAB Model (refer to footnotes 1 and 2) but to avoid confusion the most up-to-date numbers can be obtained from Norna Robertson. The symbols shown in brackets, e.g. (ab), are those used in the MATLAB model. A full list of descriptions of these symbols with supporting diagrams are contained within document T040072³.

- The target geometric and mass values are as follows:

Dimensions for CPTYPE ETM U-I Mass (D040350 - D040360) Date: July 16, 2004

Dimension		Target Value	Actual Value	Notes
Mass	m	22kg	21.97kg	Aiming to match 22kg
Width of main body	nx	130mm	130mm	
Length of main body	ny	500mm	520mm	
Thickness of main body	nz	84mm	78mm	
Width of t-section	tnx	130mm	90mm	at thickest part
Length of t-section	tny	200mm	170mm	
Thickness of t-section	tnz	60mm	29.5mm	at highest part
Moment of Inertia X-dir	lnx	0.4678 kg-m ²	0.502 kg-m ²	"Actual" Values quoted are for the Main U-I Mass. U-I Reaction Mass values are similar.
Moment of Inertia Y-dir	lny	0.0436 kg-m ²	0.0576 kg-m ²	
Moment of Inertia Z-dir	lnz	0.4858 kg-m ²	0.509 kg-m ²	

- The **dimensions** for the **T-sections** of the U-I Mass are determined by several factors:
 - Aiming to best match the MATLAB Model's parameters for Moment of Inertia
 - Avoid interference with upper/lower wires
 - Provide accommodation for OSEM coils
 - The Top Mass must support the suspension of two further masses of total mass 80kg via the bottom blades.
 - The bottom plate of the sandwich, that supports the blade assemblies, should be checked via hand calculation and FEA to ensure that they are stiff enough to support this weight without significant bending (see Appendix 2).
- The Main and Reaction U-I Masses must be able to be suspended within 5mm of each other without interference.

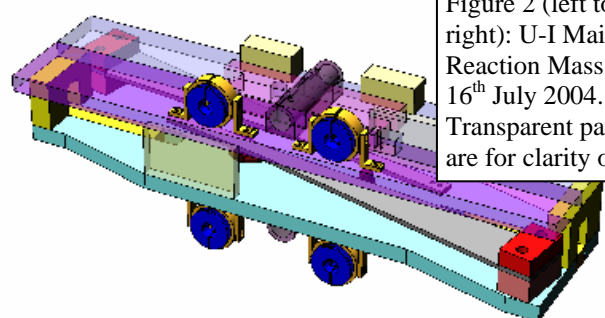
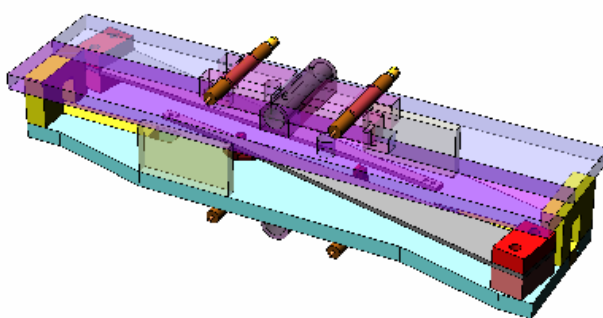

Figure 2 (left to right): U-I Main & Reaction Mass as of 16th July 2004. Transparent parts are for clarity only.

³ T040072 'Pendulum Parameters and Naming Conventions'

5. INTERFACING SUB-ASSEMBLIES

There are a number of interfacing subassemblies that need to be considered in during the design of the top mass. It is worth noting that the persons responsible for design of the sub-assemblies in the CPTYPE ETM are specified in the 'Task List' document, T040016.

Key interfacing sub-assemblies of the design are as follows:

- The **blades** for the Top Mass will have/be⁴:
 - Length (l_{2b}) = 370mm
 - Width (a_{2b}) = 49mm
 - Thickness (h_{2b}) = 4.3mm
 - a crossed layout with a $\frac{1}{2}$ break-off separation (n_2) = 140mm (see figure below)

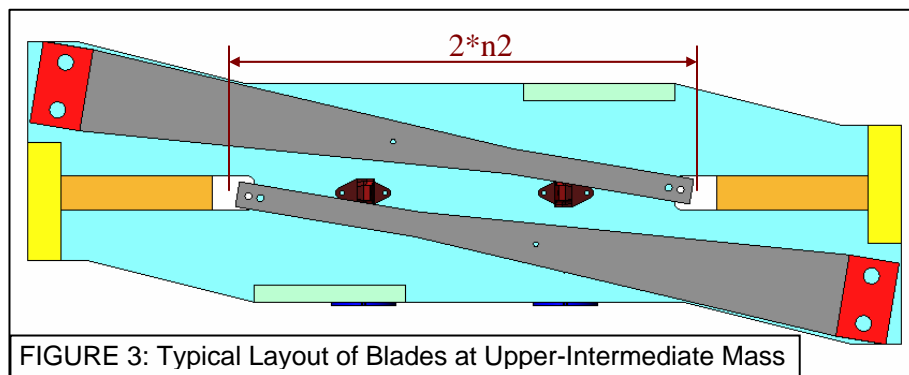

- Positioned within the U-I Mass such that the Penultimate Wires break-off⁵ at 1mm below the centre of mass (d_1)
- The **Upper-Intermediate wires** must have suitable **break-off clamps** positioned such that the wire break-off point:
 - Is at 1mm above the centre of mass (d_0)⁵
 - Is 60mm from the central y axis (n_1) i.e. 120mm total
 - There are **two** U-I wires at each break-off clamp.
- **Middle Wire Break-off Clamps:**
 - may be adjustable as per those in the MIT Quad or the ETM Quad Layout Design (see figure, right)
 - must fit between the two bottom blades without interference (refer to Appendix 1)

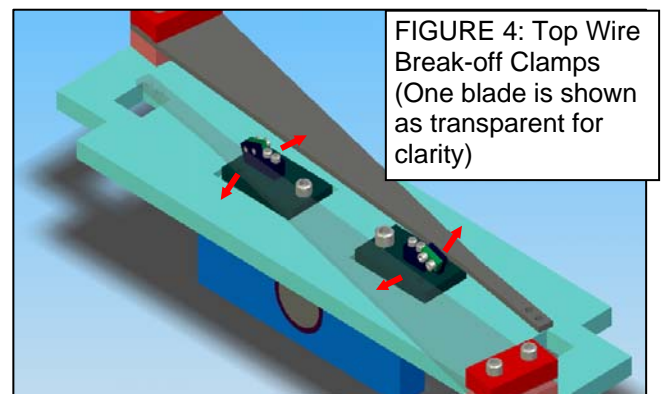

⁴ See email from Norna Robertson, April 04 2004 entitled 'revised blade sizes'

⁵ The stated break-off point is the wire flexure or bending point and not the physical break-off points where the wire leaves the clamp. For the calculation, see document D040183 Flexure Point of a Steel Wire.

- The **Top Plate** of the mass must be constructed such that the bottom half of the mass can be assembled and suspended without its attachment. Experience from past designs has shown that this makes it easier to attach the unloaded blades and attach of the top wire break-offs. Again, this could be done as per the MIT Quad or the ETM Quad Layout Design (see below)

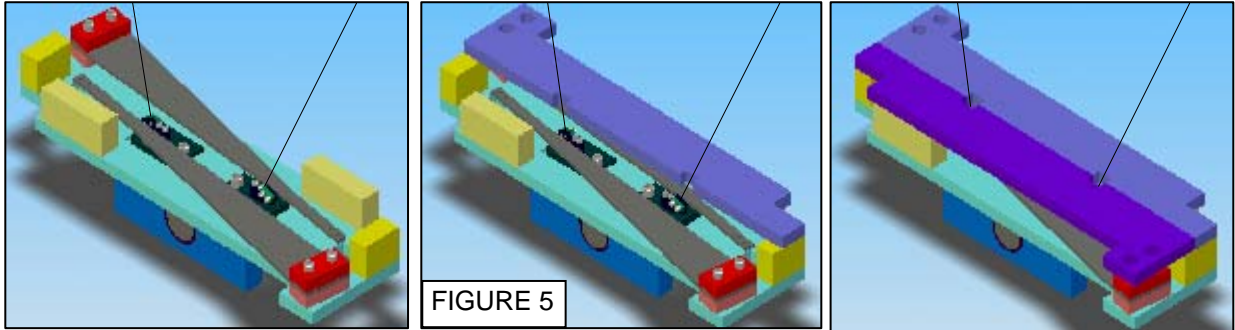

- A method of **Pitch Adjustment** similar that in the layout design of the ETM Top Mass (see figure below) must be incorporated into the U-I mass design. The size that the pitch offset mass should be will be derived from the results of a comparison between the physical MC Pitch adjuster and the MATLAB predictions⁶.

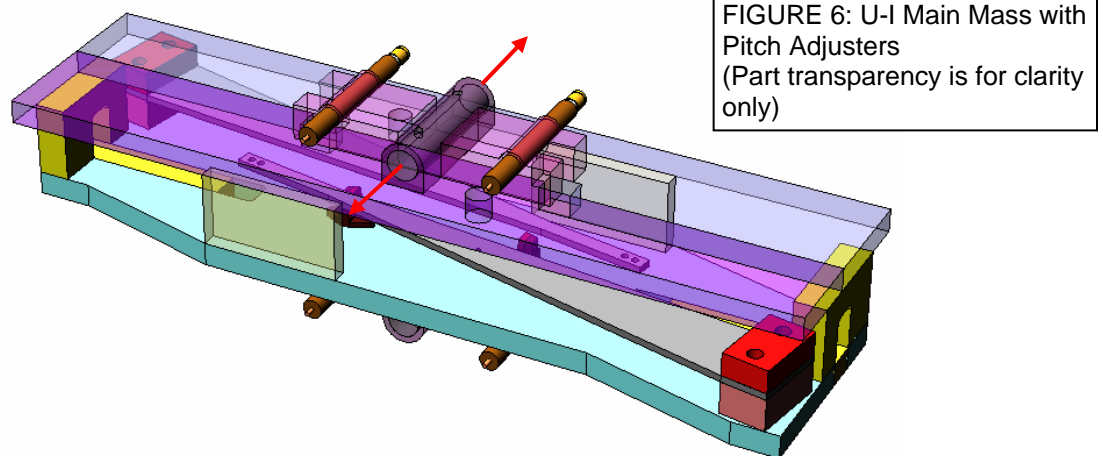

- These **pitch adjusters** could be developed with a facility for the addition or removal of mass as per the Recycling Mirror concept⁷
- **Global control** in the form of **coil-magnet actuators** will be positioned between the main and reaction upper-intermediate mass assemblies.
 - There are to be four actuators mounted between the two U-I masses.
 - The actuators should be positioned on the front face such as the dimension in the y-direction is the same as that in the z-direction i.e. positioned in a square pattern (see figure below). Currently this is set at $Y=Z=120\text{mm}$.

⁶ T030716; Concepts for Mode Cleaner Pitch Adjustment; M.Perreur-Lloyd, A.Grant; C.I.Torrie, B.Bland

⁷ T030734; Concept for Addition/Subtraction of 500g to/from the Recycling Mirror Intermediate Mass; M.Perreur-Lloyd, A.Grant; C.I.Torrie

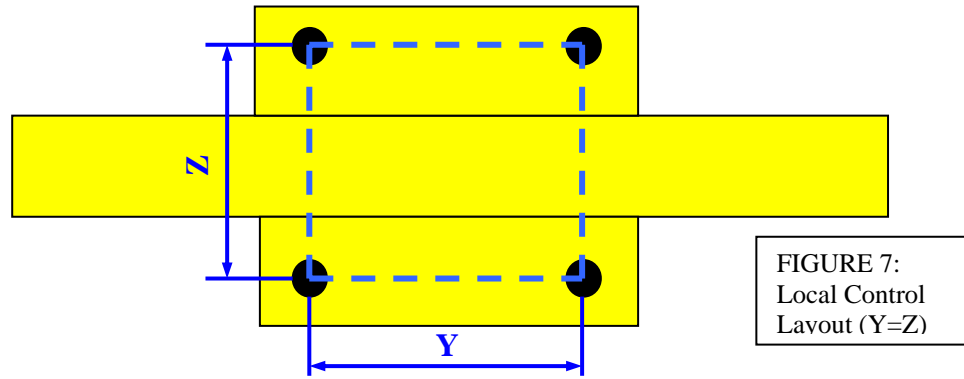

FIGURE 7:
Local Control
Layout (Y=Z)

- The **magnets** that attach to the Main Chain are of diameter 10mm and 10mm in length.
- The **coils** used will be global control specific versions of the Hybrid OSEMs (D030105).
- The **Magnet-Flag Assemblies** and **Coils** on the main and reaction U-I masses respectively, should, between them, have adjustment in pitch, longitudinal and vertical directions.
 - The current design incorporates an OSEM coil with vertical and pitch adjustment whilst the Spacer-Magnet-Flags adjust longitudinally (see figure below-right).
 - This design was deemed the better (as opposed to using fixed magnet-flags and fully adjustable OSEMs) for the following reasons:
 - It takes in to account that the Main and/or Reaction U-I masses may be suspended at an angle to ensure the test mass is accurately aligned with the beam.
 - It allows for the whole magnet-flag assembly to be removed should a flag-magnet assembly break.
 - Simplifies the OSEM adjustment mechanism in a restricted environment (ergonomically).

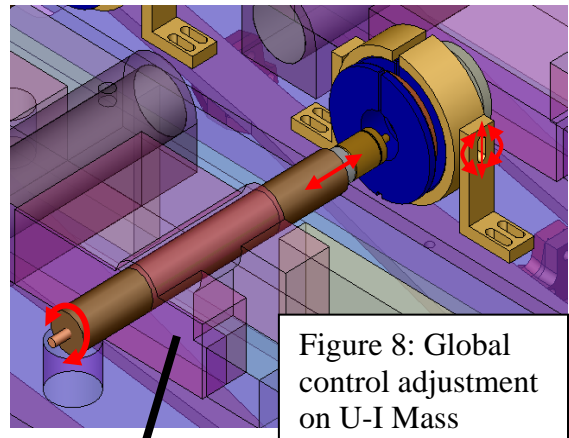
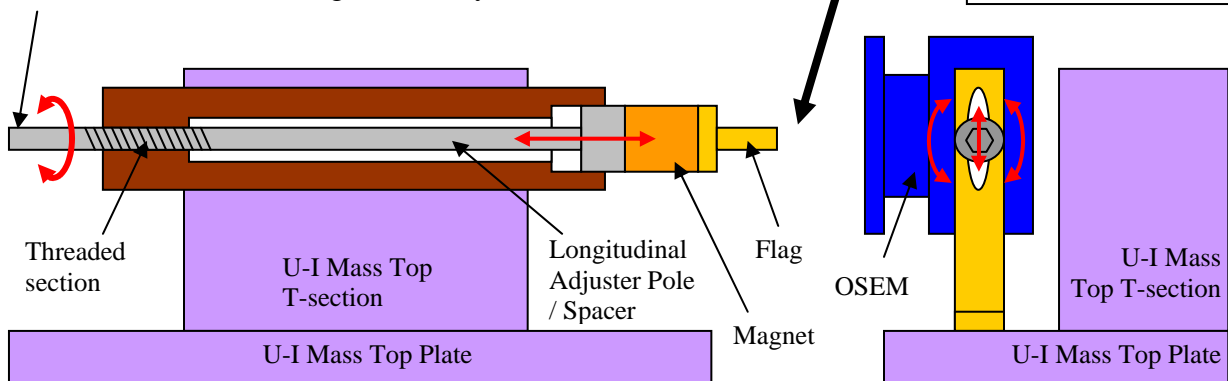
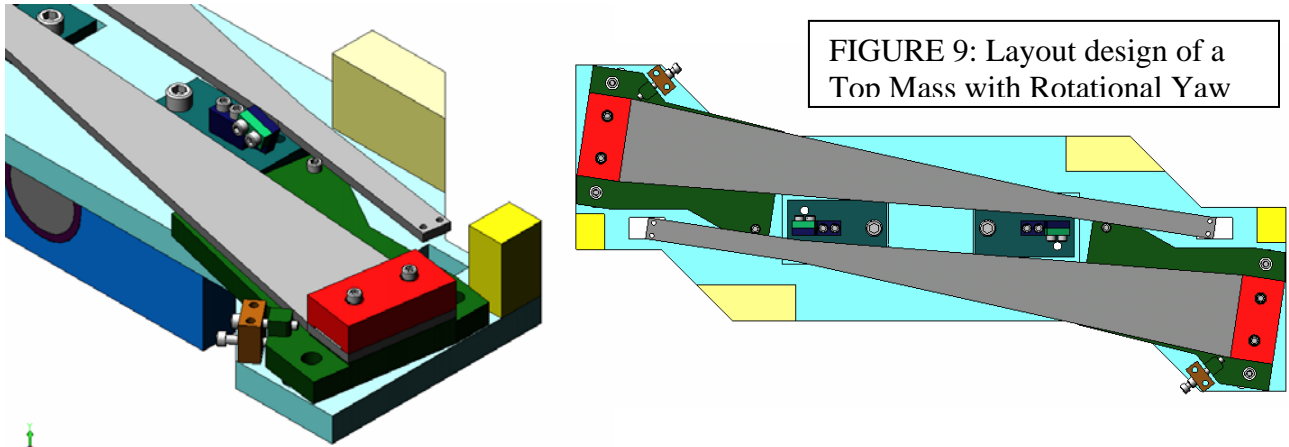

Figure 8: Global control adjustment on U-I Mass

Pole can be turned at this end to adjust longitudinally



- **Rotational (Yaw) adjusters**, such as those shown in one of the top mass layout design's configurations (see below), should be incorporated if space is available.



- **Future Interfacing Sub-Assemblies** - Thinking ahead to the Noise Prototypes, where the penultimate and test masses in the main chain will be of monolithic sapphire construction, the penultimate wires will probably have to be mounted upon movable arms attached to the Silica Mass Catcher⁸. The reason for this is due to the requirement for the wire to be in place, between the fibres, prior to welding. In consideration of this requirement, slots have been cut in the U-I Mass bottom plate to allow for these arms moving a Clamp-Wire-Clamp assembly (see below):

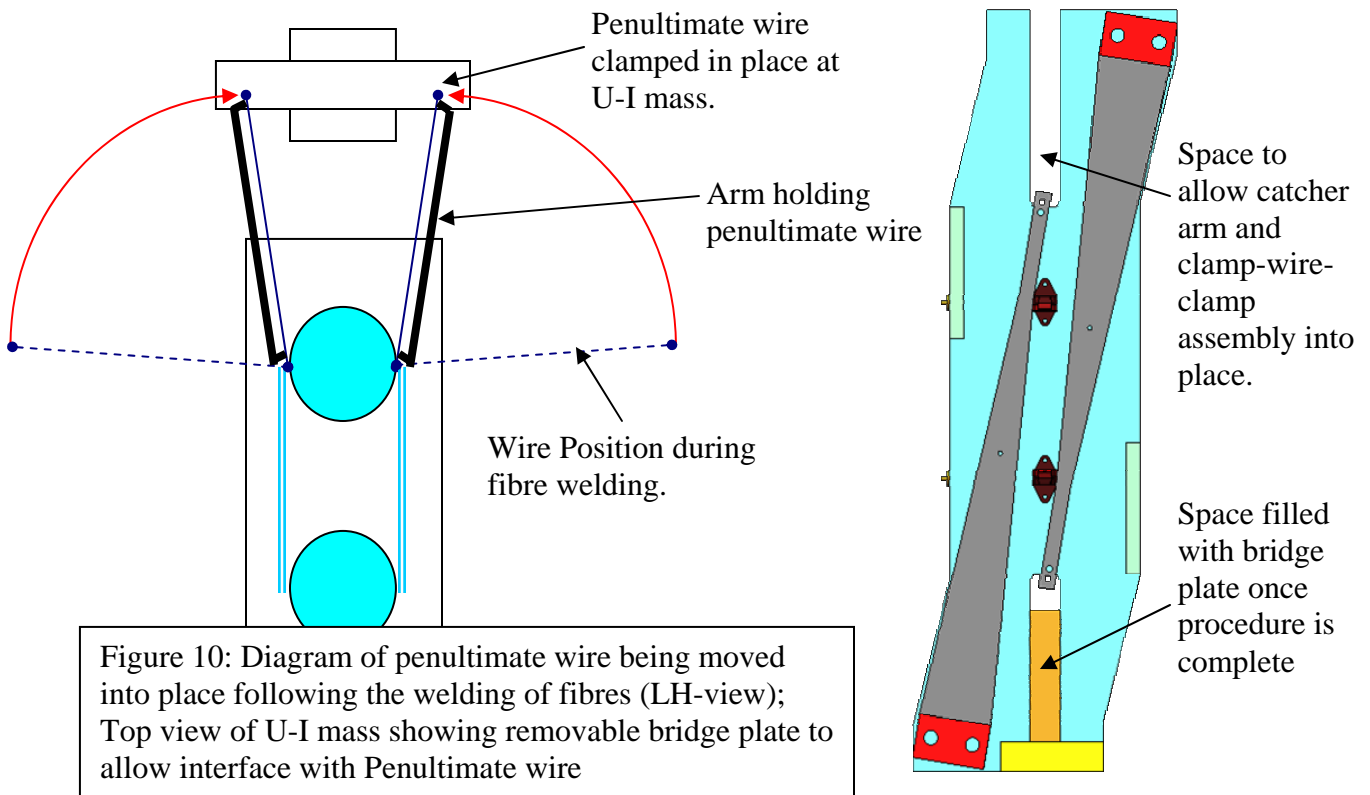

⁸ T040080; Advanced LIGO SUS ETM Catcher Jig Design Specification; Russell Jones

6. MANUFACTURE AND CLEANING OF PARTS

- All parts should be manufactured using water soluble lubricants as specified in the notes of the LIGO ‘Smart’ CAD Templates⁹
- All parts for the U-I mass assemblies should be cleaned to LIGO Standard¹⁰

7. MANUFACTURING AND ASSEMBLY DOCUMENTATION

- Part and assembly design, creation of manufacturing drawings and appropriate release documentation should be completed in accordance with the LIGO Mechanical Drawing Guidelines¹¹.

8. ASSEMBLY AND INSTALLATION

- Must be easily assembled preferably using stock imperial fasteners.
- As no lubricants (e.g. grease, oil) can be used during assembly or installation, parts should be designed to avoid cold welding (galling) by the following methods:
 - All threaded holes should use oversized taps
 - +0.003in for #2-56
 - +0.005in for #4-40 and larger
 - Bolts into Aluminium parts should be stainless steel
 - Bolts into Stainless Steel parts should be silver plated stainless steel
 - All clear holes should be specified in accordance with the Advanced LIGO guidelines¹² and ASME guidelines
- Installation of a heavy mass such as this should be considered in the design.
 - Supplementary parts may need design to aid the installation.
 - Modular construction may ease the installation.
- The un-deflected blades will be installed onto the bottom plate of the U-I mass. Additional tooling will be required to flatten the blade whilst the top plates and blade stop is applied.

9. ENVIRONMENT

- Parts must be suitable for usage in an Ultra High Vacuum environment
- The top mass must be easily assembled and installed in clean room conditions.

⁹ D030382; Summary of the Drawing and Data Templates, Macros, Bill of Materials and Customized Toolbox created for SolidWorks and an Introduction to the LIGO Caltech PDMWorks Vault

¹⁰ E960022; LIGO Vacuum Compatibility, Cleaning Methods and Qualification Procedures

¹¹ E030350; Mechanical Drawing Guidelines; Dennis Coyne, Janeen Romie, Calum Torrie

¹² T030118 Guide for Specification of Imperial Bolts, Threads and Hole Fits in Advanced LIGO Parts

10. MATERIALS

- The MATLAB model assumes an assembly made up of Stainless Steel and Aluminium (not including the blades). A suitable combination of these materials should be selected to achieve the mass, moments of inertia and strength characteristics required.
- All materials used must be suitable for High Vacuum usage and must be on the LIGO approved materials list¹³
- Parts must be manufactured from non-magnetic materials as the performance of the suspended masses can be affected by stray magnetic fields.
 - Stainless Steel 316 is the grade of steel most likely to be non-magnetic, although it cannot be said to be fully non-magnetic, and is the recommended 300 series steel to use in the suspension design.

11. QUANTITY

- A total of two full assemblies of the U-I mass are required to act as main and reaction masses. The main and reaction masses will differ however this should be limited to a small number of components that attach to an identical main body.
- Shelf spares should be manufactured/ordered for all parts
 - There should be enough shelf spares for at least one spare mass
 - For smaller parts and wire clamps numerous spares should be manufactured as these are often lost or damaged during the controls prototype build and disassembly process.

12. TESTING

- During the development of the design it may be useful to periodically test aspects of the design in relation to interfacing parts (e.g. sub-assemblies, blades, etc)
- On completion of the manufacture of each part, dimensional accuracy should be checked using micrometer, callipers or a height gauge/granite block.

¹³ E960050 LIGO Vacuum Compatible Materials List

ETM CONTROLS PROTOTYPE U-I MASS

QUESTIONS FOR DESIGN MEETING 013, MONDAY JUNE 28TH 2004

Problem: Limited space on U-I Mass bottom plate causes interference between blades and the suspended mass wire clamps.

Calum recommends that we need to have 2-3mm between the blade and the wire clamp to allow for alignment and adjustment.

Targets: Mass = 22kg
 $L_{xx} = 467,800,000 \text{ g} \cdot \text{mm}^2$
 $L_{yy} = 43,600,000 \text{ g} \cdot \text{mm}^2$
 $L_{zz} = 485,800,000 \text{ g} \cdot \text{mm}^2$

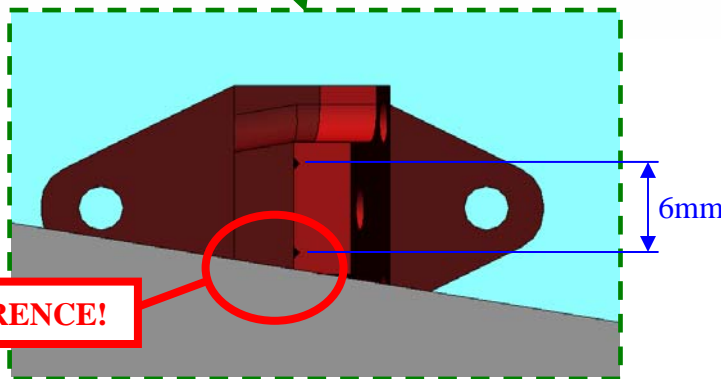
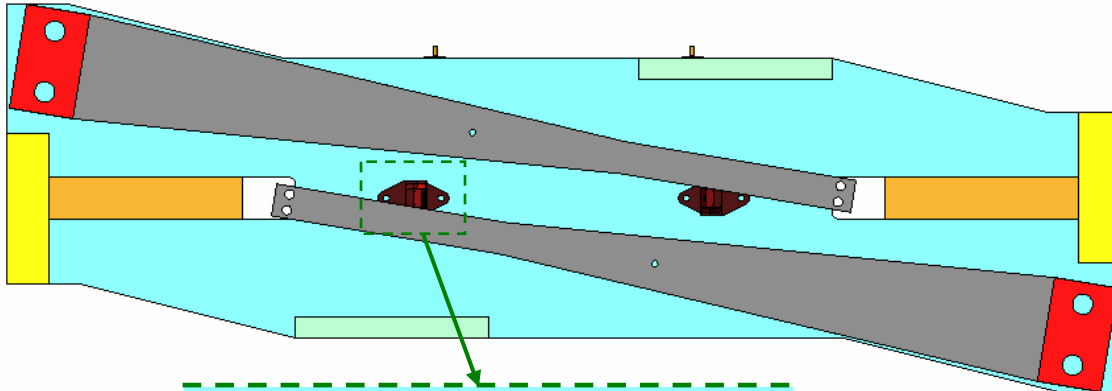
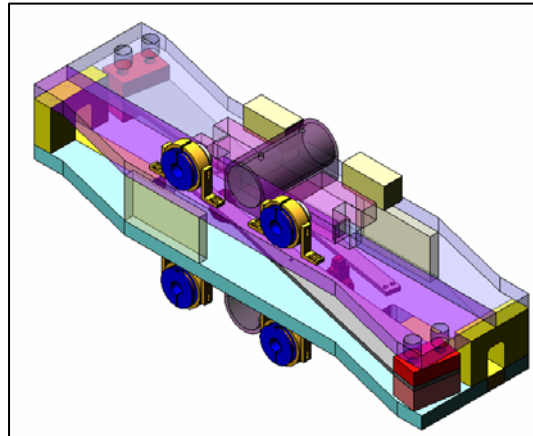

INTERFERENCE!

Mass = 21931.77 grams		
Moments of inertia: (grams * square millimeters)		
Taken at the center of mass and aligned with the output coordinate system.		
$L_{xx} = 499905516.38$	$L_{xy} = 36781749.05$	$L_{xz} = 326.19$
$L_{yx} = 36781749.05$	$L_{yy} = 59535598.76$	$L_{yz} = 0.00$
$L_{zx} = 326.19$	$L_{zy} = 0.00$	$L_{zz} = 506724169.15$

Proposed Solutions:

1) Reduce the 'n1' (half separation of the break-offs in y-dir) from 70mm to 50mm:

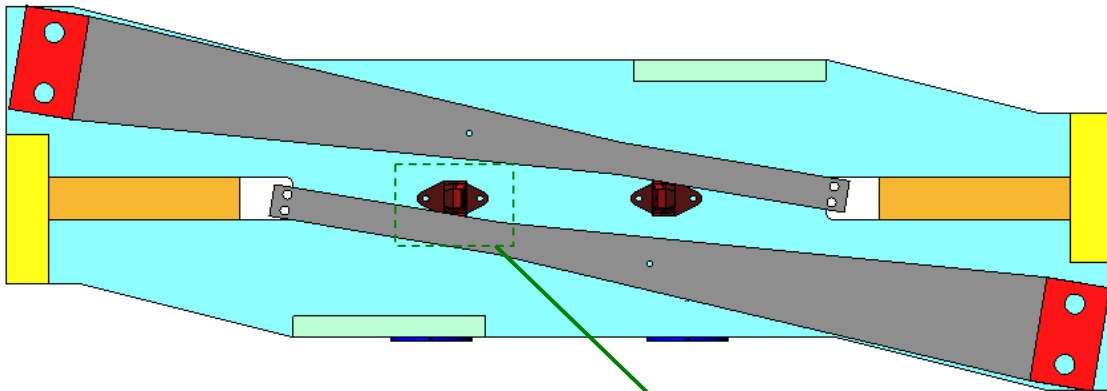

Distance between blade and wire-clamp: 2.96mm

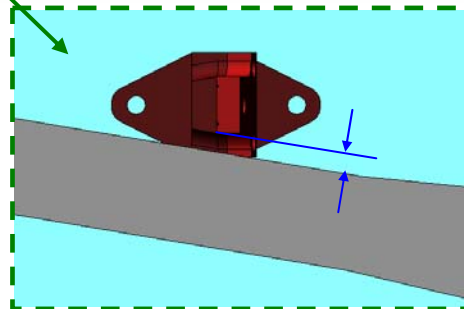

Mass = 21874.46 grams		
Moments of inertia: (grams * square millimeters)		
Taken at the center of mass and aligned with the output coordinate system.		
Lxx = 499427830.09	Lxy = 36794155.55	Lxz = -6.58
Lyx = 36794155.55	Lyy = 60447239.31	Lyz = -4174.08
Lzx = -6.58	Lzy = -4174.08	Lzz = 507949236.63

Comments:

- i. Can this be done without affecting the suspension performance?

Extract from email from NAR to MPL (concluded Sat, July 3, 2004 4:06 pm) :

>>>> Hi Norna.
>>>>

>>>> I need to know whether it would be possible to reduce the n1 value
>>>> on the Quad to 50mm from 70mm. The problem is that with the current
>>>> layout the blade will interfere with the clamp. Calum thought that
>>>> reducing n1 to 50mm shouldn't affect suspension performance greatly
>>>> considering that the n0 is 200mm.

>>> Hi Calum and Mike
>>> ...

>>> Changing n1 to 0.05 and also l1 to 0.313 (from 0.304) to keep
>>> overall length of quad the same does have a slight adverse affect on
>>> the yaw. The frequencies are Ok but coupling to the highest mode

>>> (at around 3.1 Hz) gets worse - typically the Q doubles. Although
>>> this isnt directly affecting the settling time, which is dominated
>>> by the lowest mode, I am musing about whether there could be any
>>> problems (for example applying Ken's latest ideas about damping as
>>> combination of active for the low freqs and ECD for the higher
>>> ones). I want to muse a bit longer. Will get back to you soon.

>> Mike

>>

>> I have input the numbers below into the model - looks Ok

>>

>> I wanted to ask if making n1 0.06 is enough of a change to fit in
>> wire clamps - it gives a less significant change to the yaw
>> behaviour. I am still musing on whether the 0.05 is acceptable but
>> thought i would ask anyway.

> Hi Norna.

>

> As we are looking at altering the blade to having a narrower tip it is
> not necessary to move the break-off as far from the 0.07m as I
> proposed. I have checked the model - moving the wire clamp to 0.06
> from the centre of mass - and this seems to be okay.

>

> We can stick with this value and forget about moving to the 0.05m.

HI Mike

That's good! Let's settle for n1 = 0.06. I'll check what l1 has to be to
keep overall length same.

Cheers

Norna

2) Angle blades further. Diagram shows increase from 9.5degrees to 12degrees:

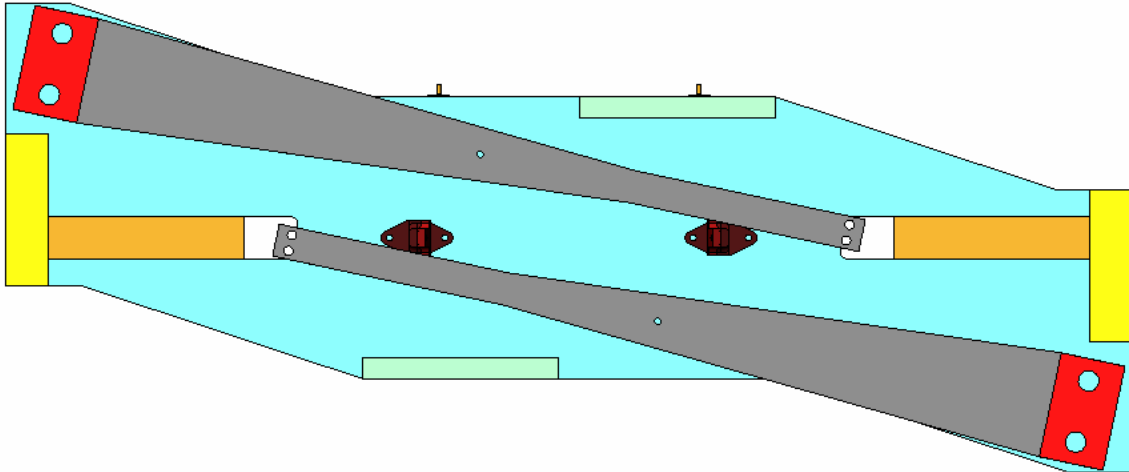

Distance between blade and wire-clamp: 2.56 mm

NOTE: Blades 11degrees gave a distance between the blade and clamp of 1.42mm

Mass = 21899.01 grams		
Moments of inertia: (grams * square millimeters)		
Taken at the center of mass and aligned with the output coordinate system.		
Lxx = 494768034.76	Lxy = 70809039.77	Lxz = 326.82
Lyx = 70809039.77	Lyy = 67849886.96	Lyz = 0.00
Lzx = 326.82	Lzy = 0.00	Lzz = 509986145.36

Comments:

- i. Off-axis Moments (Lxy, Lyx, highlighted in **RED**) increase such that they are higher than Moments in the Y plane (Lyy).
- ii. Norna – I expect that this is not good?!

3) Reduce blade width at tip to 10mm:

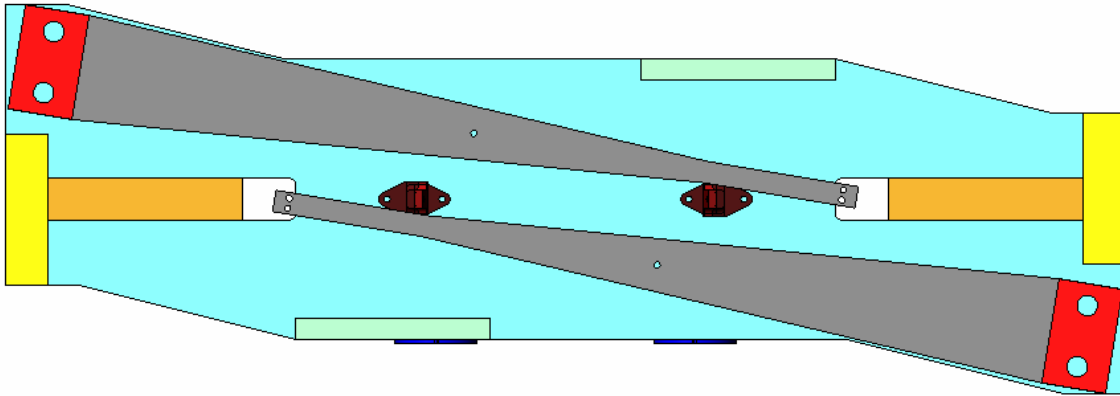

Distance between blade and wire-clamp: 2.16 mm

Mass = 21845.50 grams

Moments of inertia: (grams * square millimeters)

Taken at the center of mass and aligned with the output coordinate system.

Lxx = 499309960.58	Lxy = 36813068.34	Lxz = -6.55
Lyx = 36813068.34	Lyy = 60443359.65	Lyz = -4174.30
Lzx = -6.55	Lzy = -4174.30	Lzz = 507827602.04

Extract from an email between MPL and MVP Jun 24th 2004

```
>>>I have a quick question about blades. I am having some problems
>>>related
>>>to lack of space and interference at the U-I mass of the ETM quad and
>>>was wondering if this could be solved by making the blades slightly
>>>narrower. The bottom blades are 370mm long 49mm wide and currently
>>>have a width of 15mm at the thin end. The thin end of the blade is
>>>straight all the way down rather than getting wider from a neck.
```

```
>>>
```

```
>>>So my question is:
```

```
>>>Would it be okay to move to a 10mm width at the thin end instead of
>>>15mm?
```

```
>>>
```

```
>>>I know that in the past that you generally preferred not going below
>>>12mm however I imagine this may have been in the situation where
>>>there was a neck?!
```

```
>>>
```

```
>>>Let me know.
```

```
>>>Thanks.
```

```
>>>Mike P-L.
```

```
>>To answer your question about the blades. It sounds like the design
>>you are proposing has a trapezoidal shape. Is this correct? I suppose
>>the issue then is how much material there is around the holes drilled
>>for the clamp. If the holes are one behind the other then 10 mm width
>>is probably OK. Of course the spring constant of the blade will be
>>slightly
>> different with this revised shape but it is hard to say how much it
```

>>will change.
 >>
 >>Regards
 >>Mike Plissi

>Hi Mike.
 >Thanks for getting back to me. Just to make sure we are both talking
 >about the same shape of blades I have drawn up a quick diagram.
 >
 >See the attached and confirm that this shape of blade was what you were
 >considering with your earlier reply.
 >Thanks.
 >Mike P-L.

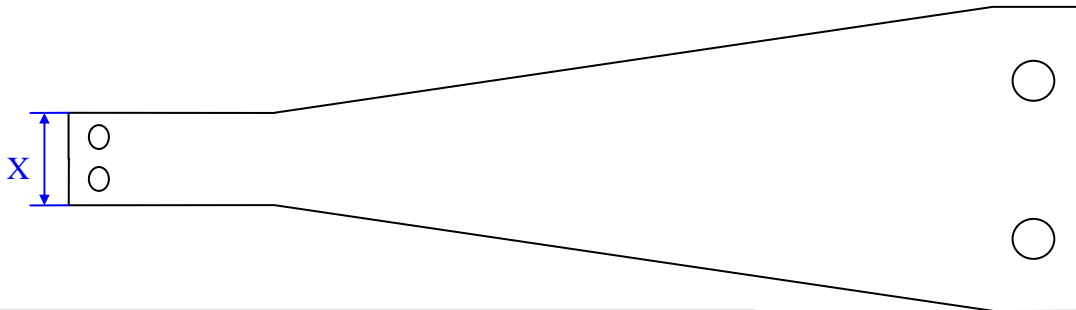

The blades look like this (approximately!).

Currently the bolts are #8-32 (4.2mm DIA) and the width X=15mm

However, I want to change these to bolts #4-40 bolts (2.8mm DIA) and a width of X=10mm.

OK, I now understand the shape that you described. It looks reasonable assuming that:

1. The bolts are strong enough for the loads involved
2. The bolt heads do not interfere. (I would think that the holes must be drilled fairly close to the edge for this not to be a problem, unless you envisage a special clamp design).

Regards
 Mike Plissi

NOTE: #4-40 Socket Head bolts have a maximum head diameter of 0.183in (4.65mm) therefore two can fit laterally on a 10mm blade tip.

Comments:

- i. Is this going to affect the blade performance? Shouldn't be a problem – Comments from DM013.
- ii. Can we use #4-40 bolts for the blade wire clamp? Probably be okay (original BWC concepts has #2-56 but deemed fiddly to work with) but maybe we could use #8-32 but position the holes along the blade.

4) Raise Blades to Avoid Interference:

The blade collides with the clamp in the Y-Z plane by around 1.5mm. Could we raise the height of the blade to avoid this interference (adjusting for the break-off height via the blade wire clamp)?

e.g.

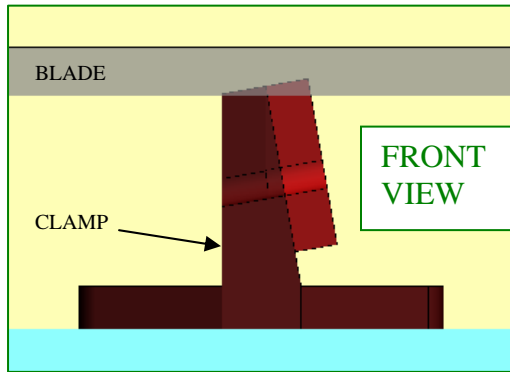

NOTE: The central axis of the plane originally was set at 1mm below the centre of gravity for the U-I mass.

i.e.

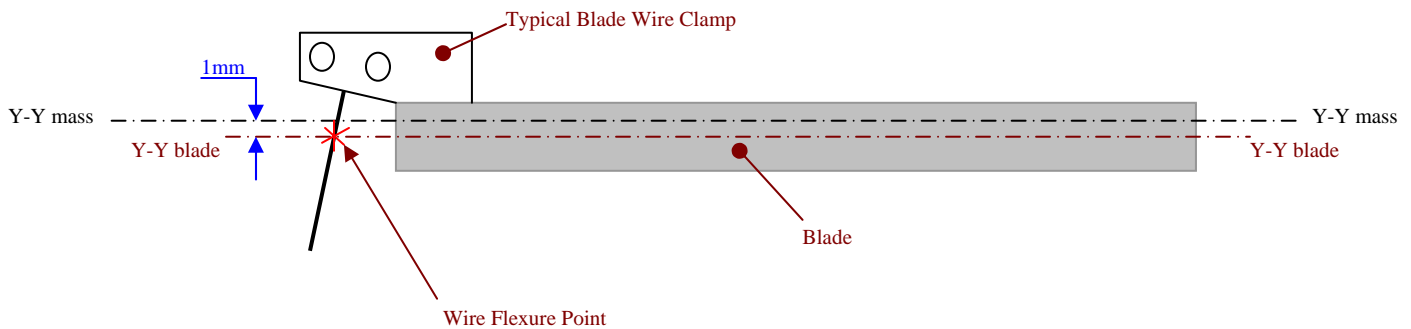

Comments:

- i. As the blade is not guaranteed to be perfectly flat under load, there is still a possibility that the blade will hit the clamp when loaded.
- ii. Moving the blade from the default position, and compensating with the clamp, will cause a cross coupling which will in-turn affect the suspension performance.

CONCLUSION TO DISCUSSIONS

It is best that a combination of solutions proposed in 1 and 3 are adopted for the design.

- Use a narrow blade design with #8-32 holes along the length of the blade.
- Reduce n1 to 60mm.

Top Mass Bottom Plate Bending Analysis – continuing...

