



MEMORANDUM

Title: Notes on As-Built Pin Valving for the HEPI Actuator
Refer to: LIGO-T040078-01
Date: 27 April 2004
Author: Dennis Coyne

Revision 01:

- a) Revised small pin dimensions per revision B of D020359. Revision B was used for the production but not (yet) filed in the DCC.
- b) Revised small pin hole dimensions in the actuator plate per revision B of D020285. Revision B was used for the production but not (yet) filed in the DCC.
- c) Revised small pin hole dimensions in the manifold plate per revision B of D020300. Revision B was used for the production but not yet filed in the DCC.
- d) Added notes on serrated edges at sealing point and chips found in a few holes, burrs at side port in a few holes.
- e) Added measurements/tests on 5 other actuators (6 total)
- f) Revised the recommended modifications to the small pin valves

The problems:

The small pins do not properly seat against their conical tips. This is based on two observations:

- Several of the installed actuators in the x-end station have significantly less displacement for a commanded voltage than the others (factors of 10 less). When the pin valves are torqued more, their sensitivity increased by still far less than the others.
- On 6 yet to be assembled actuators, the 5 pin holes and pins were tested for sealing and (for some) their dimensions measured (see below). All of the 12 manifold small pin valves make a seal. Only 3 of the 18 actuator plate small pin valves sealed.

The manufacturer for the machined parts of the actuator was supposed to confirm that the pin valves seated properly (using marker on the conical tip), but failed to catch this problem. The problem is basically a design problem with too little tolerance allowed for thread depth (nominal dimensions work with a 0.031" tolerance). While a minimum length of the o-ring bore length (nominal 0.262" dia.) was specified, an equally important maximum length (or conversely minimum thread depth) was not specified. The marker test that the pin valves seat properly should have caught this problem when the parts were inspected and before welding into the actuator assembly.

On several of the holes burrs were observed at the side port near the bottom of the small pin valve bore hole. While these burrs may not impede the small pin valve from seating they represent a small risk of migration and blockage.

In several of the holes a metal chip was found (order of .02" to .06" in size).

The bottom of the pin valve bore (nominal 0.262" diameter), which forms the sealing edge (with the nominal 0.110 through hole orifice), has significant chatter in many of the actuator plate

holes. This makes the sealing edge serrated. While this may prevent a perfect seal, it is deemed acceptable since small leakage (weeping) past the pin valves in actuator run mode is acceptable.

Suggested solution:

- 0) Check all bores and remove side port burrs and metal chips.
- 1) Modify the existing pins as follows (revision C, see figure 4):
 - a) reduce the threaded region length by 0.043" (from 0.168" to 0.125") by lathing off about 1 thread, thereby increasing the piston length. This will leave 3 threads remaining.
 - b) lathe down the thread major diameter to 0.363" (from 0.373"). This is the minimum diameter for a 3/8 – 24 UNF thread.

Measurements & Tests:

Permanent marker test: Check to see if the pin tip seats in the hole, or if rubbing occurs along the 'piston' diameter of the pin by marking the surfaces with permanent marker. See results in the table below.

Measurements were made on actuator assembly D020285-B, as indicated in the figures and table below, for serial numbers: 037, 042, 043, 056, 063 and 076.

Modifications were made to the pins step by step and measurements and tests of sealing made at each step, for serial number 042 (as indicated in the table below).

Figure 1: Actuation Plate (D020285-A) holes (3) [N.B.: production revision is B, A is shown here just to indicate which holes are designated A, B and C]

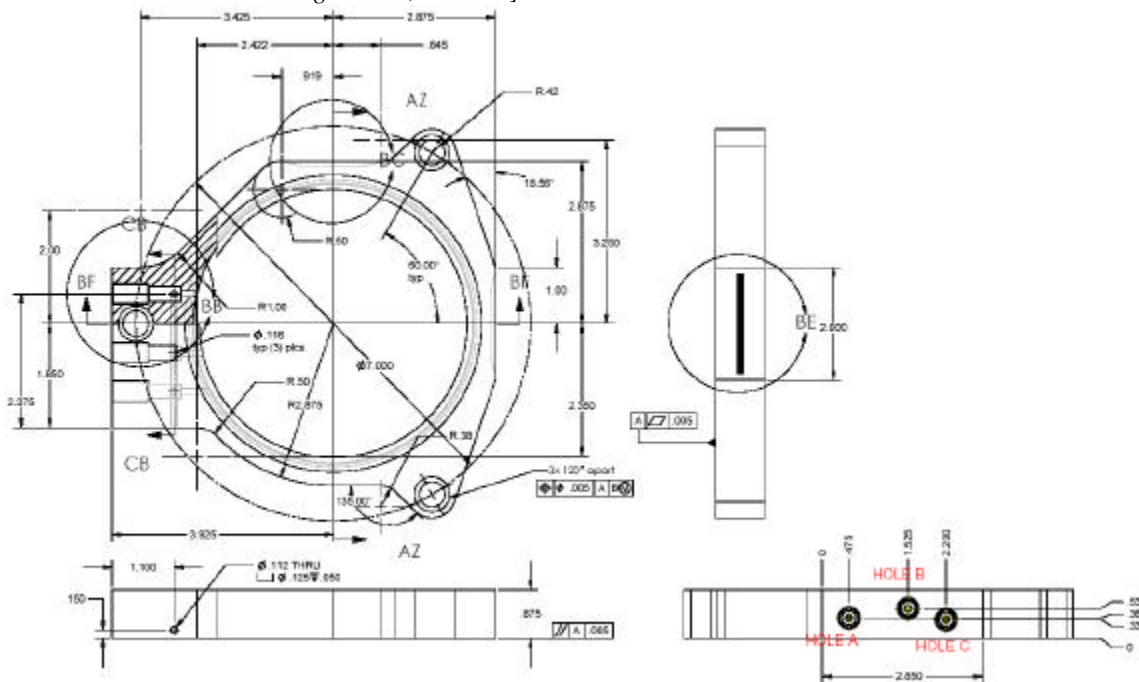

Figure 2: Actuation Plate Hole Dimensions (D020285-A with Revision B markups indicated)

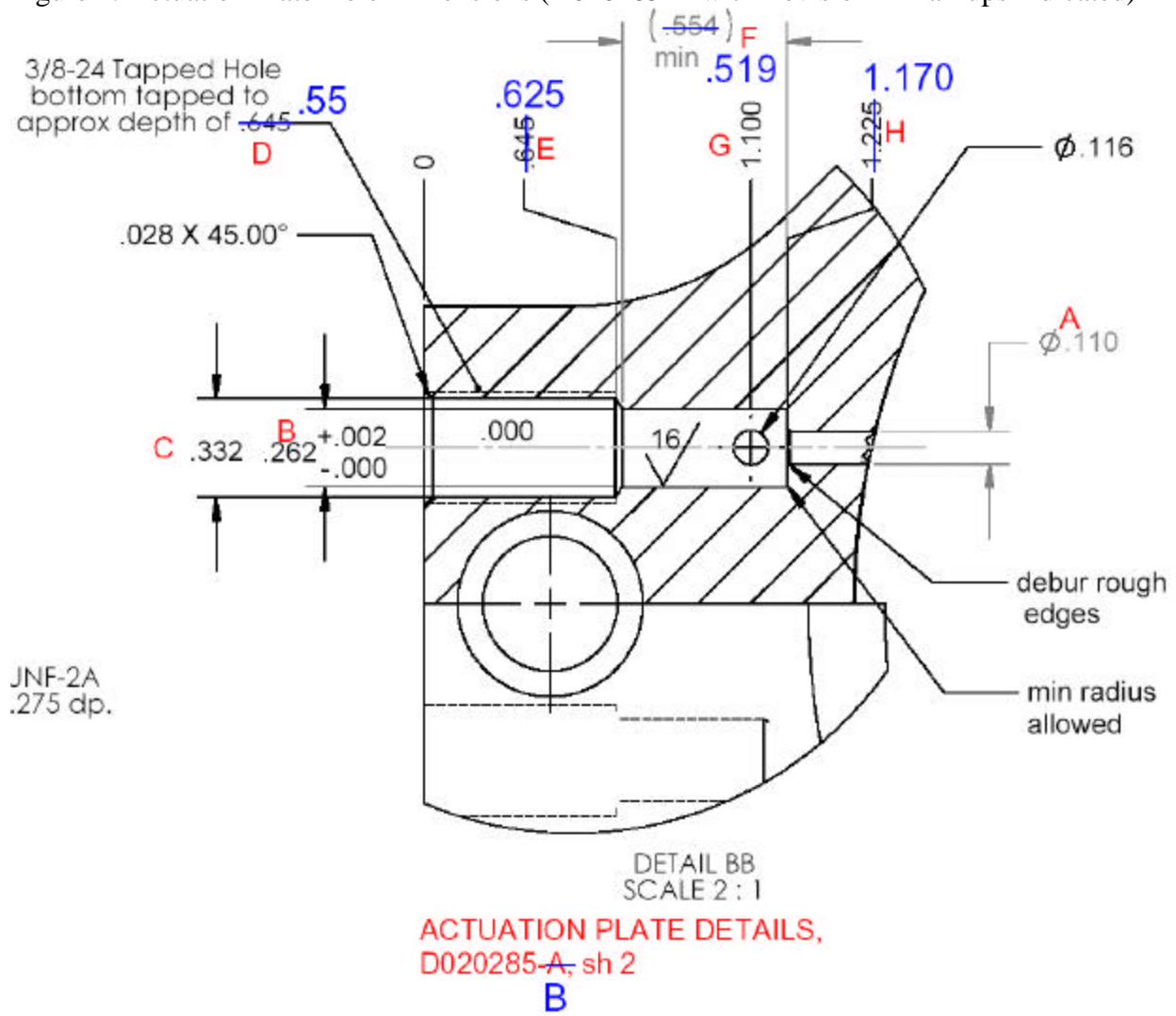

Figure 3: Small Pin Dimensions (D020359-B, sh 1) [Initial Production Revision]

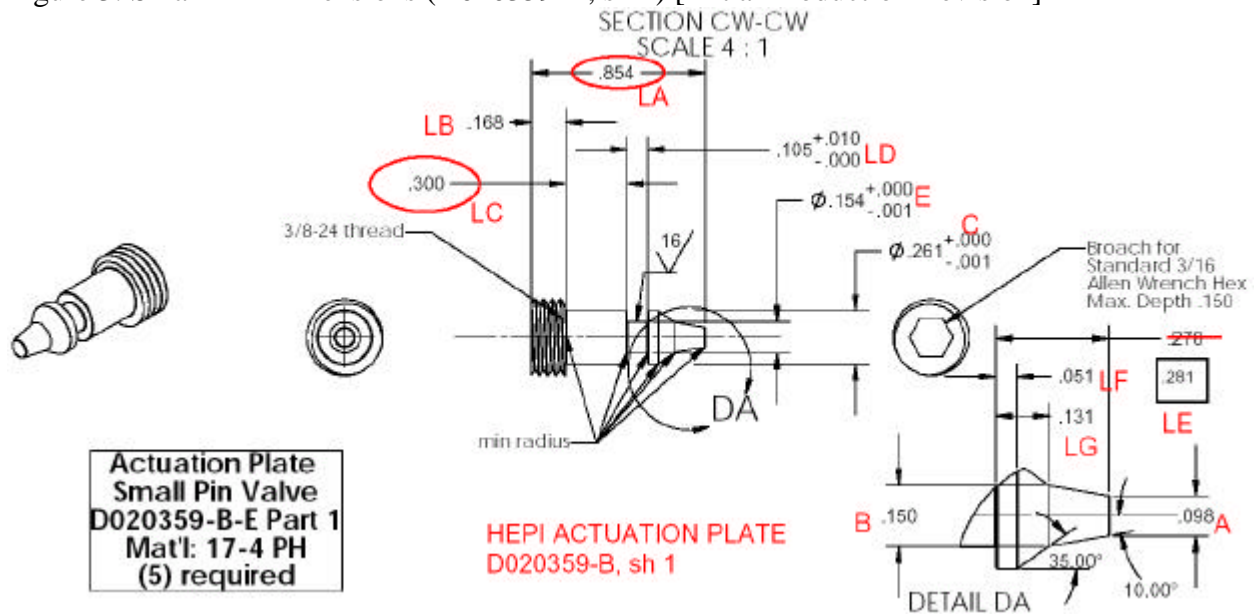

Figure 4: Small Pin Dimensions (D020359-C, sh 1) [Proposed Revision]

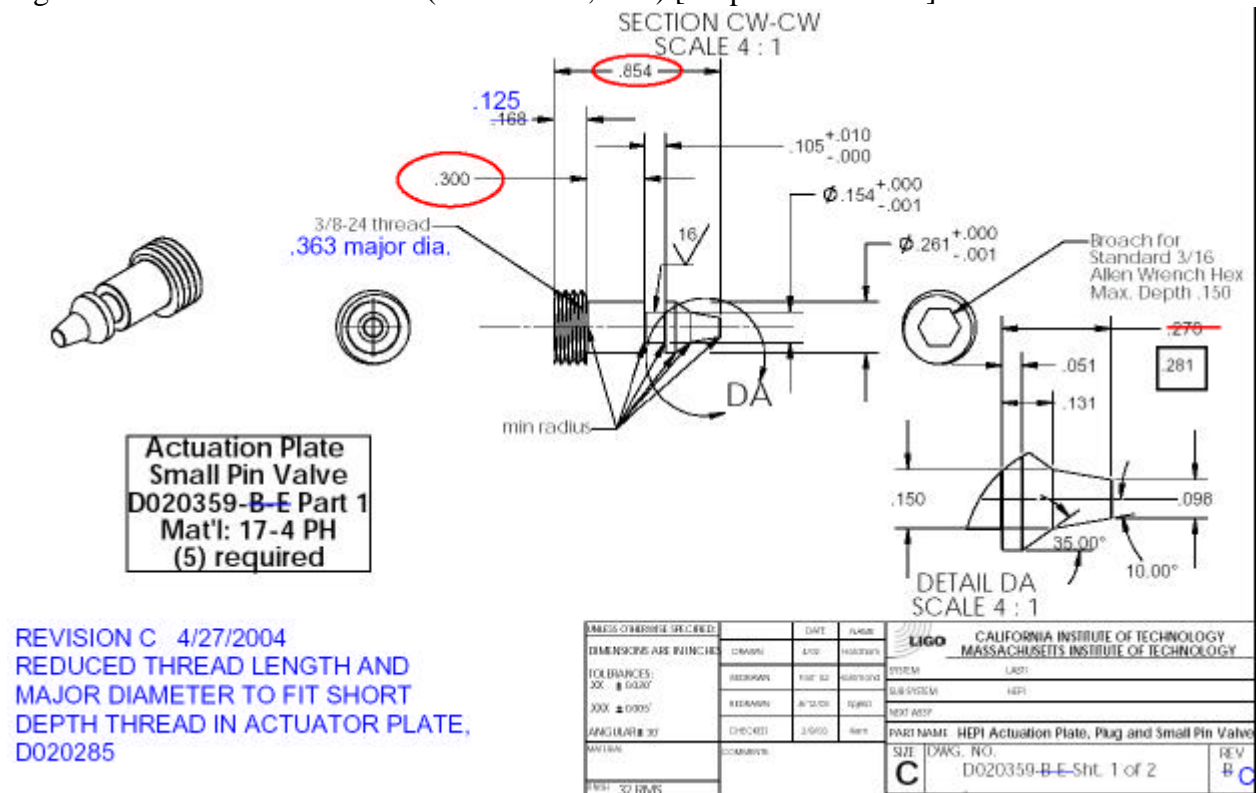
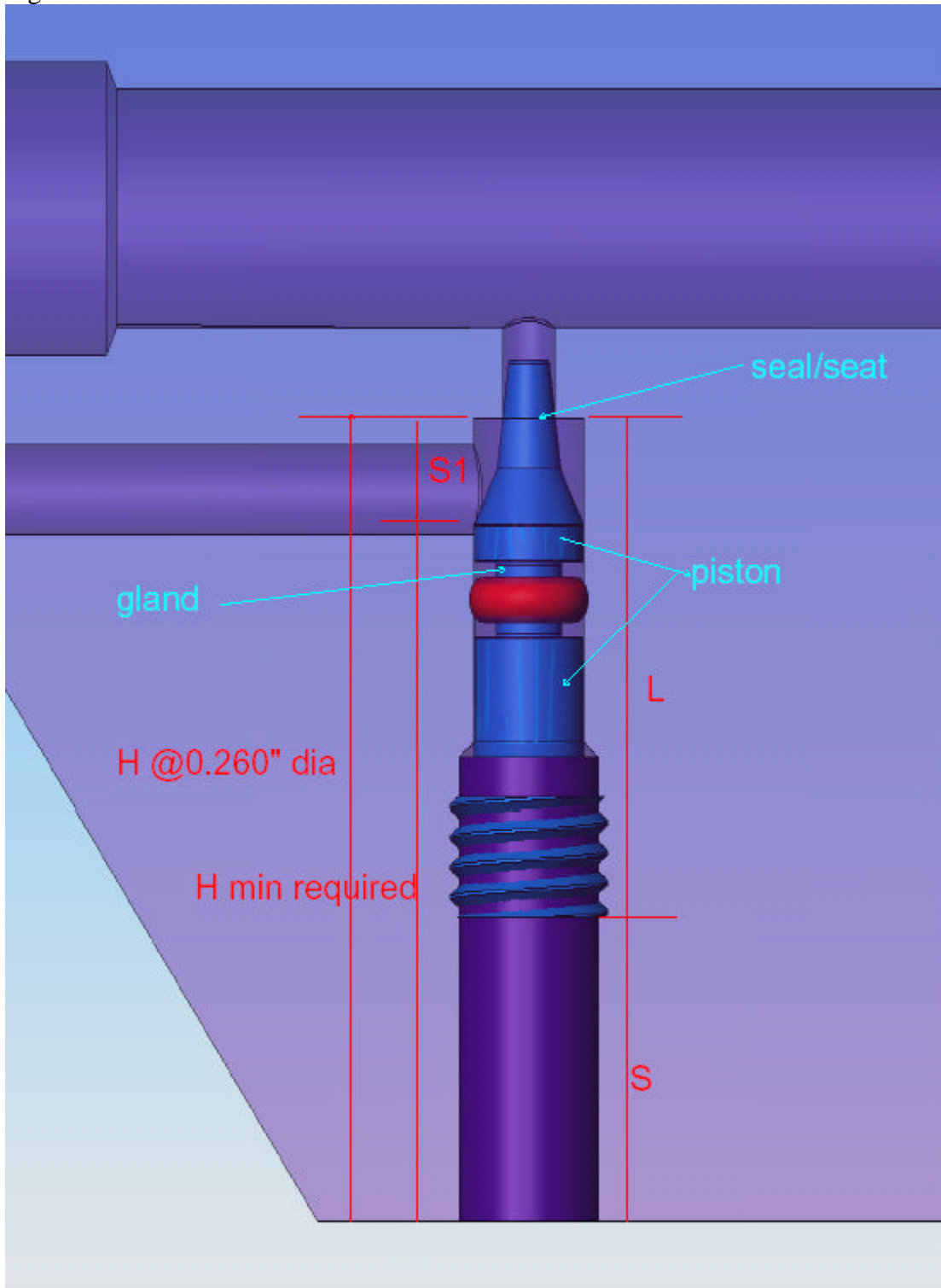

Figure 5: Small Pin in situ Dimensions



Permanent Marker Test

HEPI Actuator Assy. D020285-B, serial number 037

	actuator plate holes (D020285-B, sh 2)			manifold holes (D020300-B, sh 2)		conditions:
	A	B	C	D	E	
seal	X	X	X	OK	OK	with original pins Holes A, B C have chatter at bottom of bore
seal	OK barely	OK barely	270 deg			MODIFIED PIN: 0.028" less thread (LB=.140) 0.356" major thread dia.
seal	OK	OK	OK barely			MODIFIED PIN: 0.035" less thread (LB=.133) 0.356" major thread dia.
seal			OK			MODIFIED PIN: 0.048" less thread (LB=.120) 0.356" major thread dia.

Note: Generally the rubbing location on the 'piston' of the pin is at the same azimuthal location.

Key:

X = no seal

OK = sealed all around

n deg. = partial seal of n degrees

0 = no rubbing on pin "piston" diameter

1vs = very slight rubbing on one side

1s = slight rubbing on one side

1 = significant rubbing on one side

2vs, 2s, s = rubbing all around

Holes for Small Pin Valves

all dimension in inches

Dimension	Nominal	actuator plate holes (D020285-B, sh 2)		manifold holes (D020300-B, sh 2)		D	E
		A	B	C	D		
A	0.110 for actuator 0.124 for manifold						
B	0.262 +.002, -.000	diameter	depth	diameter	depth	diameter	depth
		0.262	1.010	0.262	1.029	0.262	1.015
		0.261	1.096	0.261	1.137	0.261	1.088
		0.260	1.166	0.260	1.167	0.260	1.166
C	0.332						
D	approx. 0.550 actuator approx. 0.645 manifold		0.519		0.524		0.525
E	0.625 actuator 0.666 max manifold						
F <- (H-E)	0.519 min actuator 0.454 min manifold						
G	1.100						
H (@0.260 dia.)	1.170 actuator 1.120 manifold		1.166		1.167		1.166
(H-D) calc	0.620 actuator 0.475 manifold						
Available Pin Depth @0.098 dia.	--						

used "plus" cylinder gauges appears to be in spec

Small Pin Valves

Pins (D020359-B) from HEPI Actuator Assy. D020285-B, serial number 037

all dimension in inches

Dimension	Nominal +/- .005	PIN from HOLE:				
		A	B	C	D	E
A	0.098					
B	0.150					
C tip						
C root	0.261 +.000, -.001					
E	0.154 +.000, -.001					
LA	0.854					
LB	0.168					
LC	0.300					
LD	0.105 +.010, -.000					
LE	0.281					
LF	0.051					
LG	0.131					
LA ~ LB+LC+LD+LE	0.773	0.000	0.000	0.000		
L w/ 0.110 dia.	0.651					
	should be > hole (H-D) + .005 margin	NG	NG	NG		
L w/ 0.125 dia.	0.611					
	should be > hole (H-D) + .005 margin				NG	NG
S	--					
Scalc ~ H - L - LB	--	0.000	1.167	1.166	-0.169	-0.169
S1 = L-LC-LD-LF		0.000	0.000	0.000	-0.454	-0.454
Hreq = H@0.260 - S1		0.000	1.167	1.166	0.454	0.454
H@0.262						
H@0.262 > Hreq +margin .050?		NG	NG	NG	NG	NG

difficult to measure; approx.
difficult to measure; approx.
difficult to measure; approx.

Permanent Marker Test

HEPI Actuator Assy. D020285-B, serial number 042

	actuator plate holes (D020285-B, sh 2)			manifold holes (D020300-B, sh 2)		conditions:
	A	B	C	D	E	
seal	X	X	X	OK	OK	with original pins
piston		1	1	1vs	1s	with original pins
seal	X	X	X			pin from D
piston		2	1	1		pin from D
seal	X	X	X			pin from E
piston		1	1	1		pin from E

Note: Generally the rubbing location on the 'piston' of the pin is at the same azimuthal location.

Key:

X = no seal

OK = sealed all around

n deg. = partial seal of n degrees

0 = no rubbing on pin "piston" diameter

1vs = very slight rubbing on one side

1s = slight rubbing on one side

1 = significant rubbing on one side

2vs, 2s, s = rubbing all around

Tests on Machined/Modified Pins

Condition	Measurement of depth of pin from top of hole, S (in)			manifold holes (D020300-B, sh 2)		notes
	A	B	C	D	E	
Initial Pins	0.329	0.342 ?	0.347 ?			no sealing
Pin B after: - piston dia. Reduced - thread major dia. reduced	0.348	0.348	0.347			no sealing
Pin A after: - major dia, reduced	0.341	0.342	0.340			no sealing
Pin C, no changes	0.331	0.331	0.330			no sealing
Pin B after: - piston dia. Reduced - thread major dia. Reduced - less ~1 thread, LB=0.136	0.368 seals rubs on piston at tip	0.367 seals no rubbing	0.365 seals rubs on piston tip			Seals! same azimuthal location for rubbing
Pin C - less ~1 thread (LB=0.136)	0.351 no seal rubs a lot on piston	0.350 no seal rubs a lot on piston	0.350			
Pin C - less ~1 thread (LB=0.136) - thread major dia, 0.364	0.362 partial seal, ~270 deg	0.361 partial seal, ~90 deg	0.364 partial seal, ~270 deg			
Pin C - less ~1 thread (LB=0.136) - thread major dia, 0.364 - piston dia. 0.259, 0.258	0.364 partial seal	0.366 partial seal	0.365 partial seal			
Pin C - less ~1 thread (LB=0.136) - thread major dia, 0.364 - piston dia. 0.259, 0.258	0.367 full seal rubs	0.365 just barely seals slight rubbing	0.365 full seal rubs			

Holes for Small Pin Valves

all dimension in inches

Dimension	Nominal	actuator plate holes (D020285-B, sh 2)			manifold holes (D020300-B, sh 2)	
		A	B	C	D	E
A	0.110 for actuator plate 0.124 for manifold	0.109	0.108	0.108	0.125	0.125
B	0.262 +.002, -.000	0.262 to depth 1.029	0.262 to depth 1.107	0.262 to depth 0.991	0.262 to depth 1.087	0.262 to depth 1.076
		0.261 to depth 1.166	0.261 to depth 1.159	0.261 to depth 1.079	0.261 to depth 1.090	0.261 to depth 1.111
		0.260 to depth 1.165	0.260 to depth 1.165	0.260 to depth 1.160	0.260 to depth 1.114	0.260 to depth 1.115
					0.259 to depth 1.116	
				0.258 to depth 1.119		
C	0.332	0.330	0.330	0.330	0.333	0.333
D	approx. 0.550 actuator approx. 0.645 manifold	0.523	0.515	0.521	0.659	0.651
E	0.625 actuator 0.666 max manifold					
F <- (H-E)	0.519 min actuator 0.454 min manifold	0.536	0.540	0.534	0.488	0.488
G	1.100					
H (@0.260 dia.)	1.170 actuator 1.120 manifold	1.165	1.168	1.163	1.128	1.126
(H-D) calc	0.620 actuator 0.475 manifold	0.642	0.653	0.642	0.469	0.475
Available Pin Depth @0.098 dia.	--	0.479	0.235	0.241	0.453	0.450

used "plus" cylinder gauges
appears to be in spec

Small Pin Valves

Pins (D020359-B) from HEPI Actuator Assy. D020285-B, serial number 042

all dimension in inches

Dimension	Nominal +/- .005	PIN from HOLE:				
		A	B	C	D	E
A	0.098	0.101	0.099	0.100		
B	0.150	0.151	0.152	0.150		
C tip		0.2597	0.2597	0.2595	0.2597	0.2595
C root	0.261 +.000, -.001	0.2597	0.2597	0.2595	0.2597	0.2595
E	0.154 +.000, -.001	0.155	0.153	0.152		
LA	0.854	0.853	0.852	0.852		
LB	0.168	0.169	0.168	0.169		
LC	0.300	0.298	0.295	0.295		
LD	0.105 +.010, -.000	0.108	0.110	0.109		
LE	0.281	0.282	0.284	0.275		
LF	0.051	0.050	0.050	0.050		
LG	0.131	0.130	0.130	0.130		
LA ~ LB+LC+LD+LE	0.773	0.857	0.857	0.848		
L w/ 0.110 dia.	0.651	0.635	0.638	0.639	0.635	0.638
	should be > hole (H-D) + .005 margin	NG	NG	NG		
L w/ 0.125 dia.	0.611	0.603	0.604	0.605	0.602	0.602
	should be > hole (H-D) + .005 margin				OK	OK
S	--	0.329	0.342	0.347	0.358	0.360
Scalc ~ H - L - LB	--	0.361	0.362	0.355	0.357	0.355
S1 = L-LC-LD-LF		0.179	0.183	0.185	0.148	0.148
Hreq = H@0.260 - S1		0.986	0.985	0.978	0.980	0.978
H@0.262		1.029	1.017	0.991	1.087	1.076
H@0.262 > Hreq +margin .050?		NG	NG	NG	OK	OK

difficult to measure; approx.
difficult to measure; approx.
difficult to measure; approx.

Permanent Marker Test

HEPI Actuator Assy. D020285-B, serial number 043

	actuator plate holes (D020285-B, sh 2)			manifold holes (D020300-B, sh 2)		conditions:
	A	B	C	D	E	
seal	X	X	X	OK	OK	with original pins Holes A, B C have chatter at bottom of bore Holes A and B have burrs at side port
seal	OK	OK	270 deg			MODIFIED PIN: 0.048" less thread (LB=.120) 0.356" major thread dia.

Note: Generally the rubbing location on the 'piston' of the pin is at the same azimuthal location.

Key:

X = no seal

OK = sealed all around

n deg. = partial seal of n degrees

0 = no rubbing on pin "piston" diameter

1vs = very slight rubbing on one side

1s = slight rubbing on one side

1 = significant rubbing on one side

2vs, 2s, s = rubbing all around

Holes for Small Pin Valves

all dimension in inches

Dimension	Nominal	actuator plate holes (D020285-B, sh 2)		manifold holes (D020300-B, sh 2)		D	E
		A	B	C	D		
A	0.110 for actuator plate 0.124 for manifold						
B	0.262 +.002, -.000	diameter	depth	diameter	depth	diameter	depth
C	0.332						
D	approx. 0.550 actuator approx. 0.645 manifold						
E	0.625 actuator 0.666 max manifold						
F <- (H-E)	0.519 min actuator 0.454 min manifold						
G	1.100						
H (@0.260 dia.)	1.170 actuator 1.120 manifold						
(H-D) calc	0.620 actuator 0.475 manifold						
Available Pin Depth @0.098 dia.	--						

Small Pin Valves

Pins (D020359-B) from HEPI Actuator Assy. D020285-B, serial number 043

all dimension in inches

Dimension	Nominal +/- .005	PIN from HOLE:				
		A	B	C	D	E
A	0.098					
B	0.150					
C tip						
C root	0.261 +.000, -.001					
E	0.154 +.000, -.001					
LA	0.854					
LB	0.168					
LC	0.300					
LD	0.105 +.010, -.000					
LE	0.281					
LF	0.051					
LG	0.131					
LA ~ LB+LC+LD+LE	0.773	0.000	0.000	0.000		
L w/ 0.110 dia.	0.651					
	should be > hole (H-D) + .005 margin	NG	NG	NG		
L w/ 0.125 dia.	0.611					
	should be > hole (H-D) + .005 margin				NG	NG
S	--					
Scalc ~ H - L - LB	--	0.000	0.000	0.000	-0.169	-0.169
S1 = L-LC-LD-LF		0.000	0.000	0.000	-0.454	-0.454
Hreq = H@0.260 - S1		0.000	0.000	0.000	0.454	0.454
H@0.262						
H@0.262 > Hreq +margin .050?		NG	NG	NG	NG	NG

difficult to measure; approx.
difficult to measure; approx.
difficult to measure; approx.

Permanent Marker Test

HEPI Actuator Assy. D020285-B, serial number 056

	actuator plate holes (D020285-B, sh 2)			manifold holes (D020300-B, sh 2)		conditions:
	A	B	C	D	E	
seal	X	X	X	OK	OK	with original pins Holes A, B C have chatter at bottom of bore Holes A and B have burrs at side port
seal	OK	OK	OK			MODIFIED PIN: 0.048" less thread (LB=.120) 0.356" major thread dia.

Note: Generally the rubbing location on the 'piston' of the pin is at the same azimuthal location.

Key:

X = no seal

OK = sealed all around

n deg. = partial seal of n degrees

0 = no rubbing on pin "piston" diameter

1vs = very slight rubbing on one side

1s = slight rubbing on one side

1 = significant rubbing on one side

2vs, 2s, s = rubbing all around

Holes for Small Pin Valves

all dimension in inches

Dimension	Nominal	actuator plate holes (D020285-B, sh 2)		manifold holes (D020300-B, sh 2)		D	E
		A	B	C	D		
A	0.110 for actuator plate 0.124 for manifold						
B	0.262 +.002, -.000	diameter	depth	diameter	depth	diameter	depth
C	0.332						
D	approx. 0.550 actuator approx. 0.645 manifold						
E	0.625 actuator 0.666 max manifold						
F <- (H-E)	0.519 min actuator 0.454 min manifold						
G	1.100						
H (@0.260 dia.)	1.170 actuator 1.120 manifold						
(H-D) calc	0.620 actuator 0.475 manifold						
Available Pin Depth @0.098 dia.	--						

Small Pin Valves

Pins (D020359-B) from HEPI Actuator Assy. D020285-B, serial number 056

all dimension in inches

Dimension	Nominal +/- .005	PIN from HOLE:				
		A	B	C	D	E
A	0.098					
B	0.150					
C tip						
C root	0.261 +.000, -.001					
E	0.154 +.000, -.001					
LA	0.854					
LB	0.168					
LC	0.300					
LD	0.105 +.010, -.000					
LE	0.281					
LF	0.051					
LG	0.131					
LA ~ LB+LC+LD+LE	0.773	0.000	0.000	0.000		
L w/ 0.110 dia.	0.651					
	should be > hole (H-D) + .005 margin	NG	NG	NG		
L w/ 0.125 dia.	0.611					
	should be > hole (H-D) + .005 margin				NG	NG
S	--					
Scalc ~ H - L - LB	--	0.000	0.000	0.000	-0.169	-0.169
S1 = L-LC-LD-LF		0.000	0.000	0.000	-0.454	-0.454
Hreq = H@0.260 - S1		0.000	0.000	0.000	0.454	0.454
H@0.262						
H@0.262 > Hreq +margin .050?		NG	NG	NG	NG	NG

difficult to measure; approx.
difficult to measure; approx.
difficult to measure; approx.

Permanent Marker Test

HEPI Actuator Assy. D020285-B, serial number 063

	actuator plate holes (D020285-B, sh 2)			manifold holes (D020300-B, sh 2)		conditions:
	A	B	C	D	E	
seal	X	X	270 deg	OK	OK	with original pins Holes A, B C have chatter at bottom
piston		2	1	2	0	of bore
seal	X	180 deg	270 deg			with pin from E
seal	X	90 deg	180 deg			with pin from D
seal	OK	OK	OK			MODIFIED PIN: 0.035" less thread 0.364" major thread dia. 0.255" piston dia.
seal	90 deg	OK	OK			MODIFIED PIN: 0.361" major thread dia.
seal	OK	OK	OK			MODIFIED PIN: 0.026" less thread 0.356" major thread dia.

Note: Generally the rubbing location on the 'piston' of the pin is at the same azimuthal location.

Key:

X = no seal

OK = sealed all around

n deg. = partial seal of n degrees

0 = no rubbing on pin "piston" diameter

1vs = very slight rubbing on one side

1s = slight rubbing on one side

1 = significant rubbing on one side

2vs, 2s, s = rubbing all around

Holes for Small Pin Valves

all dimension in inches

Dimension	Nominal	actuator plate holes (D020285-B, sh 2)		manifold holes (D020300-B, sh 2)		D	E
		A	B	C	D		
A	0.110 for actuator plate 0.124 for manifold	0.111			0.111		0.110
B	0.262 +.002, -.000	diameter	depth	diameter	depth	diameter	depth
		0.261	1.184	0.261	1.187	0.261	1.158
		0.260	1.187	0.260	1.189	0.260	1.187
		0.259	1.190	0.259	1.190	0.259	1.190
C	0.332		0.330		0.331		0.330
D	approx. 0.550 actuator approx. 0.645 manifold		0.529		0.572		0.568
E	0.625 actuator 0.666 max manifold						
F <- (H-E)	0.519 min actuator 0.454 min manifold						
G	1.100						
H (@0.260 dia.)	1.170 actuator 1.120 manifold		1.187		1.189		1.187
(H-D) calc	0.620 actuator 0.475 manifold						
Available Pin Depth @0.098 dia.	--						

used "plus" cylinder gauges appears to be in spec

Small Pin Valves

Pins (D020359-B) from HEPI Actuator Assy. D020285-B, serial number 063

all dimension in inches

Dimension	Nominal +/- .005	PIN from HOLE:				
		A	B	C	D	E
A	0.098	0.100	0.100	0.100		
B	0.150	0.150	0.150	0.150		
C tip		0.260	0.260	0.260		
C root	0.261 +.000, -.001	0.260	0.260	0.260		
E	0.154 +.000, -.001	0.153	0.153	0.153		
LA	0.854	0.852	0.852	0.853		
LB	0.168	0.167	0.167	0.168		
LC	0.300	0.290				
LD	0.105 +.010, -.000	0.110	0.110	0.110		
LE	0.281					
LF	0.051					
LG	0.131					
LA ~ LB+LC+LD+LE	0.773	0.567	0.277	0.278		
L w/ 0.110 dia.	0.651					
	should be > hole (H-D) + .005 margin	NG	NG	NG		
L w/ 0.125 dia.	0.611					
	should be > hole (H-D) + .005 margin				NG	NG
S	--					
Scalc ~ H - L - LB	--	-0.167	1.022	1.019	-0.169	-0.169
S1 = L-LC-LD-LF		-0.400	-0.110	-0.110	-0.454	-0.454
Hreq = H@0.260 - S1		0.400	1.299	1.297	0.454	0.454
H@0.262						
H@0.262 > Hreq +margin .050?		NG	NG	NG	NG	NG

difficult to measure; approx.
difficult to measure; approx.
difficult to measure; approx.

Permanent Marker Test

HEPI Actuator Assy. D020285-B, serial number 076

	actuator plate holes (D020285-B, sh 2)			manifold holes (D020300-B, sh 2)		conditions:
	A	B	C	D	E	
seal	OK	X	OK	OK	OK	with original pins Holes A, B C have chatter at bottom of bore
seal		180 deg				with pin from C
seal		OK				MODIFIED PIN: 0.026" less thread 0.356" major thread dia.

Note: Generally the rubbing location on the 'piston' of the pin is at the same azimuthal location.

Key:

X = no seal

OK = sealed all around

n deg. = partial seal of n degrees

0 = no rubbing on pin "piston" diameter

1vs = very slight rubbing on one side

1s = slight rubbing on one side

1 = significant rubbing on one side

2vs, 2s, s = rubbing all around

Holes for Small Pin Valves

all dimension in inches

Dimension	Nominal	actuator plate holes (D020285-B, sh 2)		manifold holes (D020300-B, sh 2)		D	E
		A	B	C	D		
A	0.110 for actuator plate 0.124 for manifold						
B	0.262 +.002, -.000	diameter	depth	diameter	depth	diameter	depth
		0.261 ?		0.261	1.172	0.261	1.136
				0.260	1.175	0.260	1.175
				0.259			
C	0.332						
D	approx. 0.550 actuator approx. 0.645 manifold		0.570		0.570		0.569
E	0.625 actuator 0.666 max manifold						
F <- (H-E)	0.519 min actuator 0.454 min manifold						
G	1.100						
H (@0.260 dia.)	1.170 actuator 1.120 manifold				1.175		1.175
(H-D) calc	0.620 actuator 0.475 manifold						
Available Pin Depth @0.098 dia.	--						

used "plus" cylinder gauges appears to be in spec

Small Pin Valves

Pins (D020359-B) from HEPI Actuator Assy. D020285-B, serial number 076

all dimension in inches

Dimension	Nominal +/- .005	PIN from HOLE:				
		A	B	C	D	E
A	0.098					
B	0.150					
C tip						
C root	0.261 +.000, -.001					
E	0.154 +.000, -.001					
LA	0.854					
LB	0.168					
LC	0.300					
LD	0.105 +.010, -.000					
LE	0.281					
LF	0.051					
LG	0.131					
LA ~ LB+LC+LD+LE	0.773	0.000	0.000	0.000		
L w/ 0.110 dia.	0.651					
	should be > hole (H-D) + .005 margin	NG	NG	NG		
L w/ 0.125 dia.	0.611					
	should be > hole (H-D) + .005 margin				NG	NG
S	--					
Scalc ~ H - L - LB	--	0.000	1.175	1.175	-0.169	-0.169
S1 = L-LC-LD-LF		0.000	0.000	0.000	-0.454	-0.454
Hreq = H@0.260 - S1		0.000	1.175	1.175	0.454	0.454
H@0.262						
H@0.262 > Hreq +margin .050?		NG	NG	NG	NG	NG

difficult to measure; approx.
difficult to measure; approx.
difficult to measure; approx.