



*LIGO Laboratory / LIGO Scientific Collaboration*

LIGO-T040071-05-K

*ADVANCED LIGO*

12<sup>th</sup> July 2005

Top Mass for ETM Controls Prototype Quad Pendulum Suspension

**Product Design Specification**

M.Perreur-Lloyd<sup>1</sup>, C.A.Cantley<sup>1</sup>, N.A.Robertson<sup>1,2</sup>, C.I.E.Torrie<sup>3</sup>

1 Institute for Gravitational Research, University of Glasgow

2. Stanford University

3. California Institute of Technology

Distribution of this document:  
LIGO Science Collaboration

This is an internal working note  
of the LIGO Project.

California Institute of Technology  
LIGO Project – MS 18-34  
1200 E. California Blvd.  
Pasadena, CA 91125  
Phone (626) 395-2129  
Fax (626) 304-9834  
E-mail: info@ligo.caltech.edu

LIGO Hanford Observatory  
P.O. Box 1970  
Mail Stop S9-02  
Richland WA 99352  
Phone 509-372-8106  
Fax 509-372-8137

**Institute for Gravitational  
Research**  
**University of Glasgow**  
**Kelvin Building**  
**Glasgow G12 8QQ**  
Phone: +44 (0)141 330 3340  
Fax: +44 (0)141 330 6833  
Web: www.physics.gla.ac.uk/igr/

Massachusetts Institute of Technology  
LIGO Project – NW17-161  
175 Albany St  
Cambridge, MA 02139  
Phone (617) 253-4824  
Fax (617) 253-7014  
E-mail: info@ligo.mit.edu

LIGO Livingston Observatory  
P.O. Box 940  
Livingston, LA 70754  
Phone 225-686-3100  
Fax 225-686-7189

<http://www.ligo.caltech.edu/>

**Top Mass for the ETM Controls Prototype**  
**PRODUCT DESIGN SPECIFICATION**

NOTE: This is a working document. Please consult the authors for the latest specifications.

*Revision 00: First draft of the Top Mass PDS*

*Revision 01: Additional renderings of latest top mass design; Section 4 – Tabulated latest geometric and mass values; Section 5 – Additional information on ECD and Local Control; Section 7 – Additional Notes on Assembly and Installation.*

*Revision 02: Addition of ‘Appendix 1 - Analysis of mass bending’*

*Revision 03: Updated numbers in ‘4.Performance’, incorporated Design Brief (T040073-01)*

*Revision 04: Updated details throughout including observations from ‘as-built’ model*

***Revision 05: Updated with all comments as part of LIGO DCN - E050063-00-K***

---

**DESIGN BRIEF [FORMERLY T040073-01]**

The purpose of the Top Mass is to:

- Act as the topmost mass in a quadruple pendulum suspension chain.
- Support an Upper-Intermediate mass, Penultimate mass and Test Mass/Mirror
- Provide an interface with the middle blades (cantilever springs)<sup>1</sup>
- Provide an interface with the top wires coming from the top blades.
- Provide an interface with the Local Control Dampers<sup>2</sup>

Perform its function with geometry, mass and moment of inertia parameters that fall within the limits set by the MATLAB Quad Suspension model.

---

<sup>1</sup> The blade springs act as an interface for the wires going to the Upper-Intermediate Mass and help minimise the effects of vertical seismic noise on the suspension system.

<sup>2</sup> The local control dampers damp the low frequency suspension resonances.

**CONTENTS**

	<b>page no.</b>
<b><u>1. INTRODUCTION</u></b>	<b><u>3</u></b>
<b><u>2. FUNCTION AND PERFORMANCE REQUIREMENTS</u></b>	<b><u>4</u></b>
2.1. Past Pendulum Models	
2.2. Performance (MATLAB Quad Suspension Model)	
2.3. Function	
<b><u>3. DESIGN FOR THE INTERFACING SUB-ASSEMBLIES</u></b>	<b><u>6</u></b>
3.1. Middle Blade Springs	
3.2. Top Wire Break-off Clamps	
3.3. Pitch Adjustment	
3.4. Added Mass (Vertical Adjustment)	
3.5. Adjustment at the Blades for Pitch and Yaw Correction	
3.6. Passage of Global Control Wires from Lower Suspended Masses	
3.7. Local Control	
3.8. Eddy Current Dampers	
<b><u>4. DESIGN FOR ASSEMBLY AND DISASSEMBLY</u></b>	<b><u>10</u></b>
<b><u>5. GENERAL SPECIFICATIONS APPLICABLE TO ALL SUSPENDED MASSES</u></b>	<b><u>12</u></b>
5.1. Manufacture and Cleaning of Parts	
5.2. Assembly and Installation of the Top Mass	
5.3. Environment	
5.4. Materials	
5.5. Quantity	
5.6. Testing	
<b><u>6. OBSERVATIONS FROM INITIAL BUILD</u></b>	<b><u>14</u></b>
<b><u>7. RECOMMENDATIONS FOR NOISE PROTOTYPE DESIGN</u></b>	<b><u>14</u></b>
Appendix 1 – Analysis of Mass Bending	
Appendix 2 – Drum-Ended Wires	
Appendix 3 – Pitch Adjuster & Added Mass (Vertical Adjustment) Performance	
Appendix 4 – Future Pitch Adjuster Re-location	
Appendix 5 - Recommendations for Top Mass PDS/DCN	

## 1. INTRODUCTION

This product design specification for the Top Mass is written to ensure that no design information is ignored or omitted during the development of the design. The first draft of this document contained all known specifications at the time of writing. The PDS has evolved during the design process and now on completion of the physical assembly, details the characteristics of the actual top mass.

The Top Mass for a Quadruple Pendulum is constructed from, what looks like, two triple pendulum upper masses (one inverted) joined together one above the other to form something resembling a sandwich. The ‘filling’ within the sandwich consists of two cantilever blades (that interface with the wires that suspend the upper-intermediate mass) and some clamping fixtures for the wire coming from the top blades. On the outer surfaces of the Top Mass, provision must be made for the attachment of components that interface with the Local Control Dampers.

The specifications for the Top Mass are primarily set by the output values from the MATLAB Quadruple Suspension model for the ETM. However, other factors determine the final design of the mass and alter its make-up from the ideal model MATLAB produces. These include ease of assembly, installation and interference of parts.

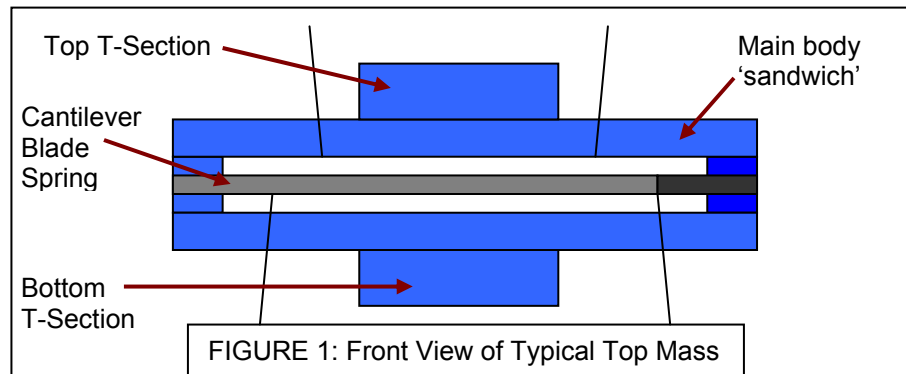

## 2. FUNCTION AND PERFORMANCE REQUIREMENTS

### 2.1. Past Quadruple Pendulum Top Mass Models

Experience and techniques from the design, manufacture and installation of the Glasgow-MIT Quad model and recent triple suspensions were considered during the design of the Top Mass.

In the early stages to developing a full working ETM Quad Controls Prototype Suspension, a layout design was drawn up. This model was used as the starting point for the conceptual and detailed design.

### 2.2. Performance Specifications

The MATLAB Quadruple Suspension Model is a mathematical model that gives specifications for a suspension design based upon the desired performance requirements for isolation and sensitivity. The dynamic performance of the Top Mass is dictated by the parameter limits given in this model. These requirements and output specifications are shown in document T040214<sup>1</sup>.

All target parameters for geometry, mass and moment of inertia given by the MATLAB model will change as the CAD solid model of the Top Mass advances. The target parameters are very much the ‘best’ theoretically but not the ‘optimum’ in terms of producing a design for ease of assembly, interfacing or use.

The design of the mass should be seen as an iterative process where any changes or additions to the solid model, and therefore changes to the mass and moments of inertia, will be passed to Norna Robertson to run through the MATLAB model. By so doing, a complex Top Mass model can be designed that has parameters that are within the allowable tolerance of all targets.

---

<sup>1</sup> T040214; Parameters for Current ETM/ITM Controls Prototype Design; N.A.Robertson, C.Torrie, et al.

### 2.3. Functional Requirements

When a top mass is suspended in a multiple pendulum, it must satisfy the following functions to allow it to perform as per the MATLAB model. The parameter symbols shown in the table [below] or in brackets, e.g. (ab), are those used in the MATLAB model. A full description of these symbols and supporting diagrams are contained within document T040072<sup>2</sup>.

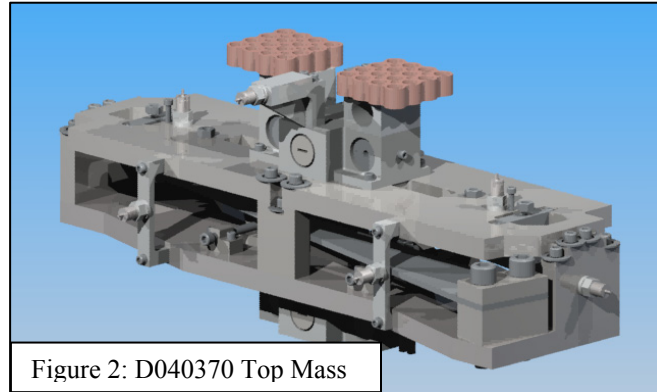

Figure 2: D040370 Top Mass

- 2.3.1. The top mass will be a universal design that can be used for both Main and Reaction suspension chains.
- 2.3.2. The main chain top mass must be able to be suspended within 5mm of the reaction top mass without interference.
- 2.3.3. The Top Mass must support the suspension of three further masses of total mass 100kg [38.4+39.6+22] via the two middle blades.
  - The bottom plate of the sandwich, that supports the blade assemblies, should be analysed to ensure that it is stiff enough to support this weight of the suspended masses without significant (around 0.5mm maximum deflection) bending [See Appendix 1].
- 2.3.4. Geometric and mass values taken from the ‘as-built’ SolidWorks model are as follows:

#### Dimensions for C-Ptype ETM Top Mass (D040370)

Date: JAN, 2005

Dimension	Symbol	Target Value (from MATLAB)	As-Built Value (from SW)	Notes
Mass	m	21.9kg	22.11kg	
Width of main body	nx	130mm	130mm	
Length of main body	ny	500mm	500mm	
Thickness of main body	nz	84mm	84mm	Top plates, bottom plates & space for blades
Width of t-section	tnx	130mm	76.2mm	at widest point; Ref: FIG.1
Length of t-section	tny	200mm	124mm	
Thickness of t-section	tnz	60mm	80mm; 38mm	Top including ECD; Bottom
Moment of Inertia X-dir	lnx	0.4740 kg-m <sup>2</sup>	0.4558 kg-m <sup>2</sup>	
Moment of Inertia Y-dir	lny	0.0704 kg-m <sup>2</sup>	0.0712 kg-m <sup>2</sup>	
Moment of Inertia Z-dir	lnz	0.4754 kg-m <sup>2</sup>	0.4547 kg-m <sup>2</sup>	
Centre of Mass		---	28.25mm	Above the top face of bottom plate

<sup>2</sup> T040072; Pendulum Parameters and Naming Conventions’

### 3. DESIGN FOR THE INTERFACING SUB-ASSEMBLIES

The interfacing subassemblies that must be incorporated in the design of the top mass are detailed below. It is worth noting that the persons responsible for design of the sub-assemblies in the C-Ptype ETM are specified in the 'Task List' document, T040016.

#### 3.1. Middle Blade Springs

The two middle blade springs, D040297, attached to the Top Mass are:

- Of length (l1b) = 420mm
- Of width (a1b) = 59mm
- Of thickness (h1b) = 4.6mm
- Arranged in a crossed layout with a  $\frac{1}{2}$  break-off separation (n0) = 200mm (see figure below). The blades in the top mass are angled by 8.5 degrees from the central axis.
- Positioned within the Top Mass such that the central axis of the blade is at **1mm below** the centre of mass (dn)
  - The blade clamps (Lower-Side), D040490, for the bench-test top mass were originally manufactured at a height of 25.7mm (ref: email MPL-IW Oct05). Since then however, due to re-machining (Feb05), **this should be revised and to 24.8 [24.95 + (4.6/2 + 1) = 28.25]**
- Attached in a flattened state by way of the Blade Transport Cage (D040590) and removable gate (D040595)
- Aligned using the Blade Alignment Jig (D050003) and Blade Tip Tool (D050117)

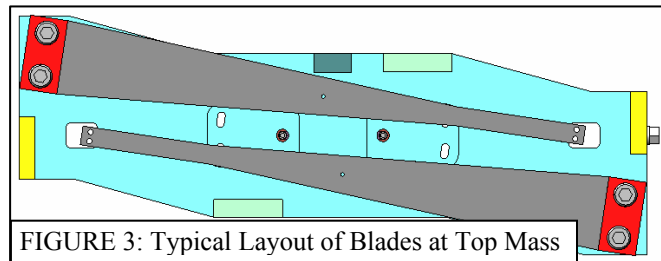

FIGURE 3: Typical Layout of Blades at Top Mass

#### 3.2. Top Wire Break-off Clamps

The top wire break-off clamps should be positioned such that the wire break-off point:

- Is at **1mm above** the centre of mass (dm) <sup>2</sup>
- Is 90mm from the central y axis (nn1) i.e. 180mm total

The top wire break-off clamps:

- Are adjustable to correct any pitch/yaw effect caused by small bolt misalignments during assembly (see right)
- Fit between the two middle blades, without interference, and with around 3mm of clearance from the blade
- Accommodate double-nail-end wires with 4x4mm DIA. double-nail-ends [see Appendix 2]

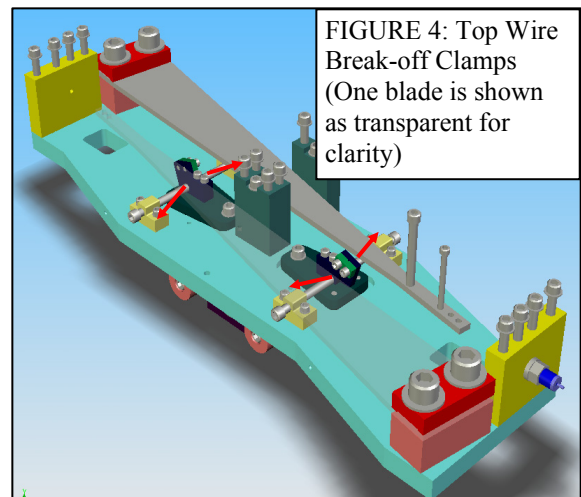

FIGURE 4: Top Wire Break-off Clamps (One blade is shown as transparent for clarity)

- Figure 5 shows the wire clamp assembly for a nail-end (or Drum-end) wire (D040534).
  - The bolt underneath the wire head is there to limit the movement of the wire during transportation.

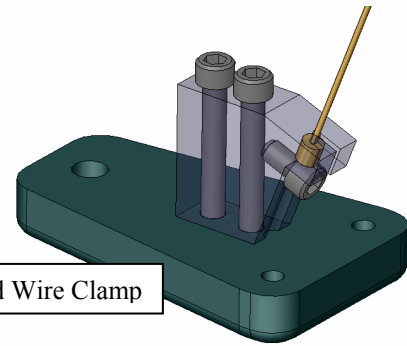

Figure 5: D040534, Drum-End Wire Clamp

**3.3. Pitch Adjustment**

- The **T-Sections** of the Top Mass incorporate two pitch adjusters of total mass 540g which provides around 20mrad of adjustment at the test mass [see Appendix 3, section 2]
- The pitch adjusters are manufactured as threaded rods that can be moved in and out via a slot in each end that interfaces with a 5/16” flat blade screwdriver.

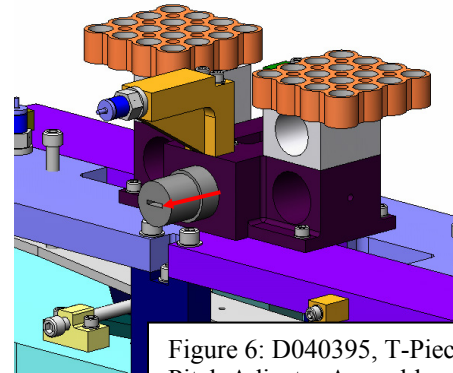
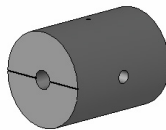

Figure 6: D040395, T-Piece Pitch Adjuster Assembly

**3.4. Added Mass**

- These **T-Sections** have been developed such that mass can be added in increments of 500grams up to a maximum of 1.5kg<sup>3</sup> [see Appendix 3, section 3]

Adding 4 of these adds 0.5kg



Adding 4 of these adds 1.0kg

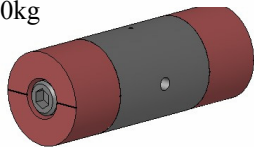

Adding 4 of these adds 1.5kg

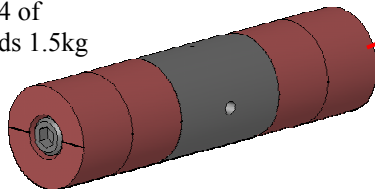
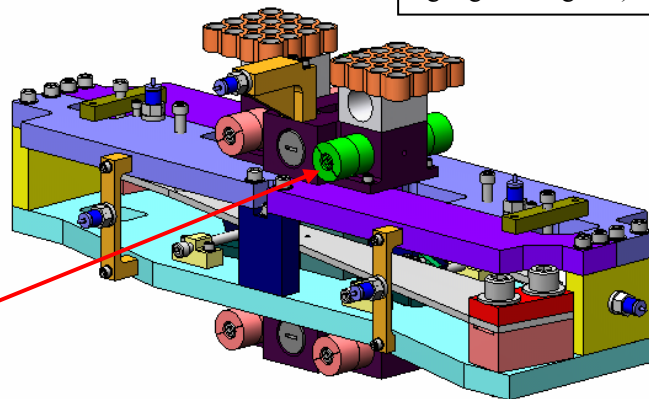

FIGURE 7: Top Mass with 1.5kg Added Mass (1/4 of the added masses is highlighted in green)



- The default assembly of the Top Mass will have 500g added (following re-machining Feb05)

<sup>3</sup> T030734 Concept for Addition/Subtraction of 500g to/from the Recycling Mirror Intermediate Mass



### 3.5. Adjustment at the Blades for Pitch and Yaw Correction

- A **Mechanical Finger** will be used for this task along with an alignment jig (D050003). For the initial controls prototype testing we will use a re-machined wrench.

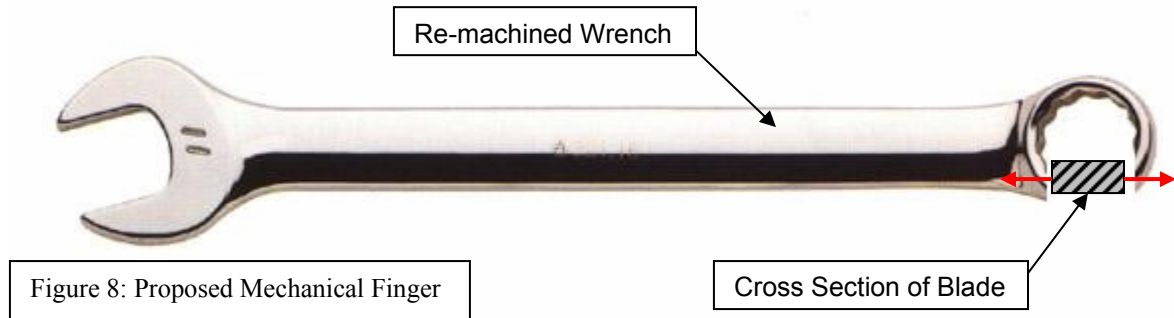

- A **Rotational Adjuster** was considered as an integral mechanism to adjust for pitch and yaw, however, it was found to be very tricky to design a mechanism that would fit in such a limited space and which would not affect the off-axis modes of inertia considerably. The mechanism was thus discarded from the design at an early stage.
  - An example of a top mass with rotational adjuster is on the Caltech PDMWorks Vault (D040521).

### 3.6. Passage of Global Control Wires from Lower Suspended Masses

- The reaction chain top mass must have a facility to fasten 32 fine copper wires coming from the global controls lower in the suspension chain. This will likely consist of a suitably positioned, non-conductive clamp, fastened to the mass via two bolts.
  - This only applies to the reaction chain top mass.
  - Fixtures should be lightweight and balanced so as not to affect the mass's dynamic performance
  - TBD – these will be added after initial build and further clarification about the path of the wires

### 3.7. Local Control

The top mass will be controlled using a combination of the Hybrid OSEMs and Magnet-flags as per the Mode Cleaner Top Mass.

- There will be six **magnet-flag/coil assemblies** at the top mass.
- The **magnet-flag assemblies** must have universal locations so that they can be positioned correctly on both the main and reaction Top Masses.
- Magnet-Flag-Spacer assemblies should be fixed to the mass such that they can be removed and replaced should a flag be broken.

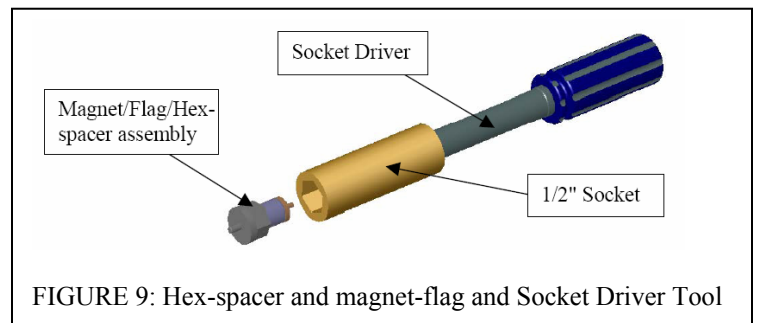
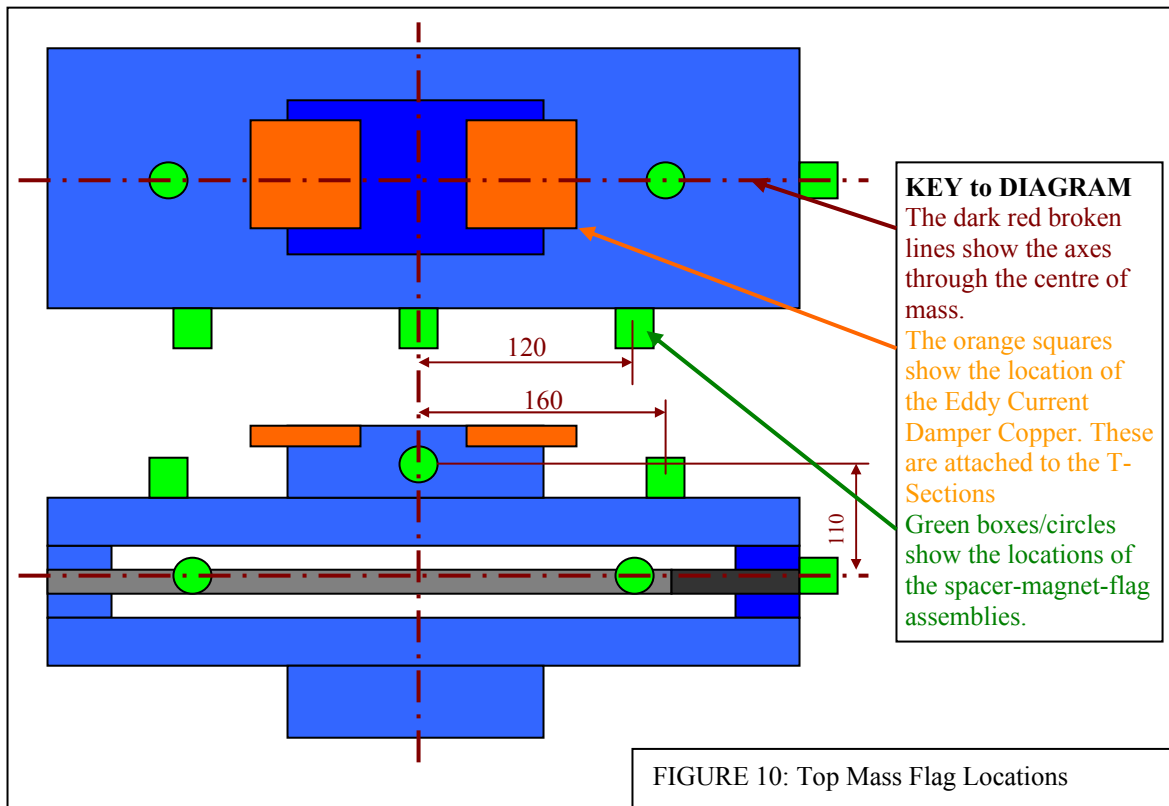

FIGURE 9: Hex-spacer and magnet-flag and Socket Driver Tool

The OSEM Coils for the C-Ptype will be the Hybrid OSEMs (D020188)

- A **Tablecloth** (D040522) attached to the Suspension structure will host the **OSEM** coils that interface with the top mass magnet-flag assemblies.



- The **OSEM** coils will be held in an adjustable mechanism attached to a tablecloth which allows for x, y and z movement, thus the magnet/flag assemblies need not be adjustable.

### 3.8. Eddy Current Dampers

- There are two **4x4 Array Eddy Current Dampers** (ECDs) damping the Top Mass.
- The copper, D020476, is attached to the mass.
- The adjustable magnet array assembly will be attached to the tablecloth.
- ECDs are located such that there is no interference between the adjustment mechanisms on the tablecloth.
- At the initial build of the C-type ETM 4x4 ECDs are assumed. Should these be replaced by lighter 3x3 or 2x2 arrays, action may be required to re-add the mass lost by attaching these assemblies. The mass loss for a 2x2 array would be of the order of 120g.

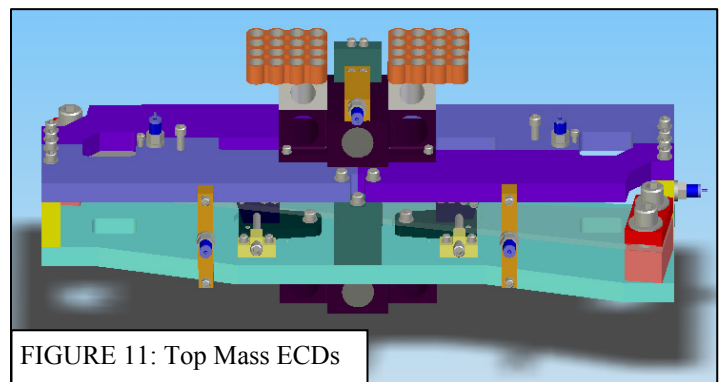

#### 4. DESIGN FOR ASSEMBLY AND DISASSEMBLY

The top mass will be assembled on an optical bench top and installed into the Structure as a cartridge assembly likely to also include the tablecloth. The tablecloth will be designed such that the Main Top Mass and Reaction Top Mass can be installed either separately or as a pair.

- Refer to the Mode Cleaner Top Mass installation document, E030518, for similar installation instructions

There are several instances where the mass will require disassembly. This may be due to the suspension being unstable when suspended or due to failure of a suspension component (e.g. a wire). The location of this disassembly may take place whilst the mass is still within the structure or possibly, once removed, on the bench where it was originally built.

The design of certain components aid the assembly and disassembly process:

##### 4.1. Bottom Plate

The mass is constructed such that the bottom half of the mass can be assembled and suspended without the attachment of the Top Plates. Experience from the Glasgow-MIT quad has shown that this makes it easier to attach the unloaded blades and attach the top wire break-offs.

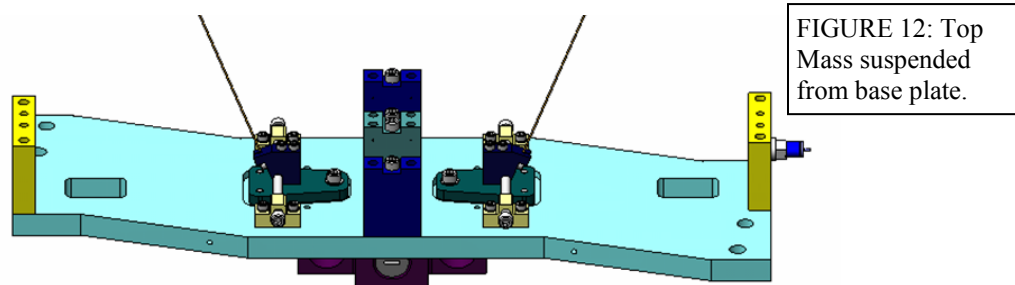

Following its assembly and attachment of wires, the top plates are attached either on the bench top or in a semi-suspended state.

##### 4.2. Top Plate

The Top Plate is designed to allow the plate to be built up in sections therefore leaving plenty of access to components such as wire clamps, wires and blades during **Assembly**.

To allow for **Dis-assembly** in-situ and for easy access to appropriate components the Top Plate quarters and the supporting posts (which attach it to the base plate) have been designed such that it can be removed either as individual components or as an assembly. By removing the top-left or bottom-right plates (see Figure 13 below) we can gain very good access to the suspended mass wire clamp, thus we can easily swap in or out a wire. Initially to get access to the top plate the top 'T-section' must be removed via the four bolts.

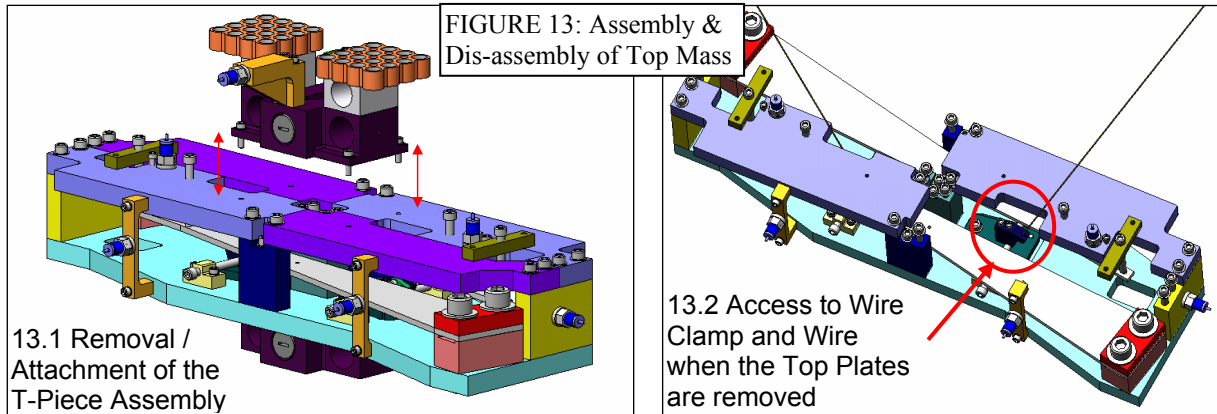

### 4.3. T-Piece Assembly

As can be seen in the above diagram 13.1, the Top and Bottom T- Sections can be attached and detached easily via four bolts. This again allows for the option of assembly or disassembly in-situ or on a bench top.

## 5. GENERAL SPECIFICATIONS APPLICABLE TO ALL SUSPENDED MASSES

### 5.1. Manufacture and Cleaning of Parts

- All parts should be manufactured using water soluble lubricants as specified in the notes of the LIGO ‘Smart’ CAD Templates<sup>4</sup>
- All parts for the Top Mass assembly should be cleaned to LIGO Standards<sup>5</sup>
- Part and assembly design, creation of manufacturing drawings and appropriate release documentation should be completed in accordance with the LIGO Mechanical Drawing Guidelines<sup>6</sup>.
- Must be easily assembled preferably using stock imperial fasteners.
- As no lubricants (e.g. grease, oil) can be used during assembly or installation, parts should be designed to avoid cold welding (galling) by the following methods:
  - All threaded holes should use oversized taps
    - +0.003in for #2-56
    - +0.005in for #4-40 and larger
  - Bolts into Aluminium parts should be stainless steel
  - Bolts into Stainless Steel parts should be silver plated stainless steel
  - All clear holes should be specified in accordance with the Advanced LIGO guidelines<sup>7</sup> and ASME guidelines

### 5.2. Environment

- Parts must be suitable for use in an Ultra High Vacuum environment<sup>8</sup>.
- The top mass must be easily assembled and installed in clean room conditions.

### 5.3. Materials

- All materials used in the Mass must be suitable for High Vacuum Usage and on the LIGO approved materials list<sup>8</sup>
- The MATLAB model assumes an assembly made up of Stainless Steel and Aluminium (not including the blades). A suitable combination of these materials should be selected to achieve the mass, moments of inertia and strength characteristics required.
- Parts must be manufactured from non-magnetic materials as the performance of the suspended masses can be affected by stray magnetic fields.
- Stainless Steel 316 is the grade of steel most likely to be non-magnetic, although it cannot be said to be fully non-magnetic, and is the recommended 300 series steel to use in the suspension design.

---

<sup>4</sup> D030382 Summary of the Drawing and Data Templates, Macros, Bill of Materials and Customized Toolbox created for SolidWorks and an Introduction to the LIGO Caltech PDMWorks Vault

<sup>5</sup> E960022 LIGO Vacuum Compatibility, Cleaning Methods and Qualification Procedures

<sup>6</sup> E030350; Drawing Requirements and Guidelines; Dennis Coyne, Calum Torrie

<sup>7</sup> T030118 Guide for Specification of Imperial Bolts, Threads and Hole Fits in Advanced LIGO Parts

<sup>8</sup> E960050 LIGO Vacuum Compatible Materials List

**5.5. Quantity**

- Two full assemblies of the top mass are required to act as main and reaction masses.
- Shelf spares should be manufactured/ordered for all parts
  - There should be enough shelf spares for at least one spare mass
  - For smaller parts and wire clamps, numerous spares should be manufactured as these are often lost or damaged during the controls prototype build and disassembly process.

**5.6. Testing**

- During the development of the design it may be useful to periodically test aspects of the design in relation to interfacing parts (e.g. sub-assemblies, blades, etc)
- On completion of the manufacture of each part, dimensional accuracy should be checked using micrometer, callipers or a height gauge/granite block.

## 6. OBSERVATIONS FROM INITIAL BUILD

### [FOLLOWING RE-MACHINING TO BENCH-TEST TOP MASS]

- 6.1. Ref: 3.1 The Blade Clamp requires re-machining
- 6.2. Ref: 3.6 Additional fixtures are required for passage of the global control wires up the reaction chain.
  - 6.2.1. Fixtures must be lightweight so as not to affect the dynamic performance of the mass.
- 6.3. Pitch OSEM could be moved lower (maybe even as far as 55mm) [\[see Appendix 4\]](#)
- 6.4. Would be helpful for tablecloth design to move bolts at each end of the mass to a counter-bored position. **ACTION TAKEN – re-machined!**
- 6.5. Would be helpful for tablecloth design to move the blade tip safety stop mounting bridge to the underside of the top plates. **ACTION TAKEN – re-machined!**
- 6.6. Top Wire Clamp adjustment mechanism is hard to access when both masses are suspended. Suggest revising design in Noise prototype Top Mass such that it can be accessed from one side (push-pull mechanism?)
- 6.7. Following the re-machining to the bench test Top Mass it is necessary for the Controls Prototype Top Mass to have 500 grams added as the default to give a mass of 22kg.

## 7. RECOMMENDATIONS FOR NOISE PROTOTYPE DESIGN

- 7.1. Ref: 3.6: Additional fixtures are required for passage of the global control wires up the reaction chain.
- 7.2. Ref: 6.3: Alter position of Pitch OSEM [\[see Appendix 4\]](#)
  - 7.2.1. If the ECDs are lowered having changed the height of the Pitch OSEM, it is important to note that the Centre of Mass of the overall assembly will change significantly.
  - 7.2.2. To determine the optimum location of the pitch adjuster it is important to check that it will not interfere with other assemblies both on the mass and on the tablecloth.
- 7.3. Ref: 6.6: Top Wire Clamp Adjustment mechanism requires redesign.
- 7.4. Ref 3.3: It should be checked that the range of the pitch adjuster used in the C-Ptype design is suitable for a silica suspension.

## Analysis of Mass Bending

The reason for the considerable effort in to this area of the design is for two reasons: 1) the earlier Glasgow-MIT Prototype Quad suspension require significant redesign to the base plate and 2) the Top Mass must suspend 100kg of mass below it. There have been three approaches taken to verify that the material thickness chosen for the Top Mass Base-Plate will not bend excessively and thus affect the break-off points of the wire significantly.

Firstly, the mass-bending calculator, developed by Dan Mason<sup>1</sup>, was used to get an idea of what would be a suitable plate thickness to use for the Top Mass base-plate.

Secondly, finite element models were created of simplified top mass designs to compare against the mass calculator results.

Thirdly, the calculated value was then scaled up slightly to conduct tests using the larger 'Blade Test Facility' Blade that is designed to suspend 61kg<sup>2</sup>. It is important to note that for added accuracy the mass-bending calculator has since been revised by Alastair Grant<sup>3</sup>.

Since then, on completion of a bench test model of the Top Mass which has a 16mm base plate, a measurement was taken on the mass which confirmed that the bending of the base plate did match the output from the earlier tests.

All of the results taken are shown overleaf.

It is important to note that on developing the top mass design it was inherent that, to stay within the 22kg mass budget, it was not possible to go much above a base-plate thickness of 16mm. During the development of the Top Mass, a design was created with an 18mm thick base-plate, however it was difficult to incorporate all of the additional sub-assemblies whilst keeping the mass below 22kg. In the end however a 16mm plate proved adequate and thus the thicker plate solution was dropped.

---

<sup>1</sup> D020811 - Analysis of Aspects of the GEO600 Style Triple and Quadruple Suspension Systems for Advanced LIGO, Section 2.3

<sup>2</sup> D050032 - Report on Visit to RAL

<sup>3</sup> D050031 - Mass Bending Calculator & Notes



**Table of ANSYS Testing on Top Mass Plate Models**

Force applied = 500N; Moment Applied = 225Nm [500Nx0.45m (Blade length)]  
 Element size = 4mm, Typical no. of elements for Plate with T-section = ~110,000

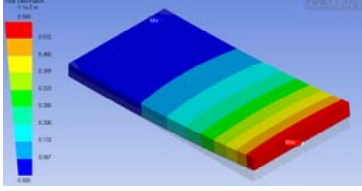
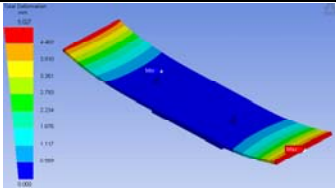
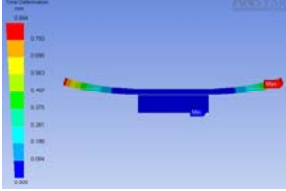
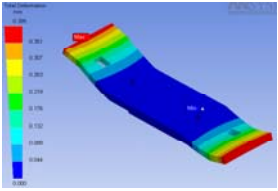
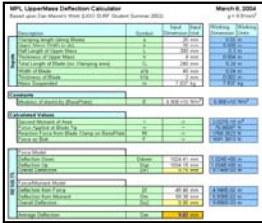
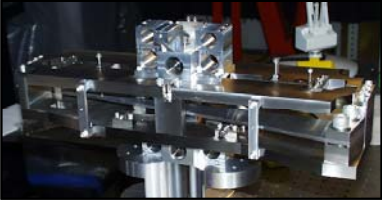
Model		Deflection					
	Plate Thickness ->	6mm	10mm	15mm	16mm	18mm	20mm
1	 <p>1/2 length plate fixed at one end with moment &amp; force applied</p>	9.33mm	2.02mm	0.60mm	0.49mm	0.35mm	0.25mm
2	 <p>Rectangular Plate fixed at breakoffs with moment &amp; force applied</p>	5.03mm	1.16mm	0.36mm	0.30mm	0.22mm	0.16mm
3	 <p>As above but with addition of angled sections for blades</p>	6.25mm	1.26mm	0.39mm	0.31mm	0.24mm	--
4	 <p>Angled Plate No T-Piece</p>	--	--	--	0.64mm	0.47mm	--
5	 <p>Mass Deflection Calculator</p>	10.32mm	2.31mm	0.69mm	0.57mm	0.40mm	0.29mm
6	 <p>Bench Test Mass</p>	--	--	--	0.6mm	--	--

**Subject:** Re: drum ended wires

**From:** ctorrie <ctorrie@ligo.caltech.edu>

**Date:** Wed, 15 Dec 2004 14:55:02 -0800

**To:** Michael Perreur-Lloyd <m.perreur-lloyd@physics.gla.ac.uk>

**CC:** "wilmut, I (Ian)" <I.Wilmut@rl.ac.uk>, Caroline Cantley <c.cantley@physics.gla.ac.uk>, "greenhalgh, RJS (Justin)" <J.Greenhalgh@rl.ac.uk>

Dear Mike and Ian

Mike sent me a draft of his top wire clamp for drum ended wires and I discussed it with Ricardo. He brought up the following which should also be applied to the top blade wire clamps

- 1) The slot should be in the front, see attached file.
- 2) Adding a cut out ensures it is easy to inspect, again see attached file.
- 3) Add a set screw to hold wire in place for transport. (I think we had already discussed this!)

He also gave me some information on the dimensions of the "heads". 4mm diameter by 4mm thick is their preferred choice. As this allows them a decent area to grip during machining and due to the ~ 0.5mm radius between the drum and the wire you get 2mm of interface between the flat part of the drum and the clamp. Again I have added this to the attached files. Can we work with 4mm x 4mm for the UI and Top wires?

I am going to start work on drawings for the wires. Each wire takes about 1-2 days to make at a cost of 300 Euros.

Thanks Calum

At 06:10 PM 12/15/2004 +0000, Michael Perreur-Lloyd wrote:

Hi Calum,

I have the head diameter for the top wire to be 5mm and I assumed a head thickness of 3mm - although this is not critical with my design - see edrawing attached.

As my clamp at the lower, U-I Mass stage would not and can not host the drum ends (both drum ends are hosted at the Middle blade), I cannot comment on the head diameter/thickness of these.

MATWEB has a UTS for "AISI Grade 18Ni (250) Maraging Steel, Aged, 16 mm round bar, tested longitudinal" as 1824Mpa.

Thanks.  
Mike P-L

ctorrie wrote:

/\_Re: drum ended wires

Dear Mike and Ian

I am gathering information for Ricardo De Salvo so that he can order the drum ended wires for the top and UI stages.

Can you help fill in the blanks wrt to your clamp designs: -

TOP WIRE: -

Wire diameter = 1.1 mm

Head diameter = ? mm

Head thickness = ? mm

Total length = I will look at this with the flexure points etc ... !

BS of Maraging steel = ? (think its the same)

Tolerance on diameter = ? mm (20 microns?)

UI WIRE: -

Wire diameter = 0.7mm

Head diameter = ? mm

Head thickness = ? mm

Total length = I will look at this with the flexure points etc ... !

BS of Maraging steel = ? (think its the same)

Tolerance on diameter = ? mm (20 microns?)

Thanks Calum

**Subject:** revised mass and MoI, pitch vert and roll adjust for controls p'type

**From:** Norna Robertson <nornar@stanford.edu>

**Date:** Wed, 22 Sep 2004 18:27:51 -0700

**To:** ctorrie <ctorrie@ligo.caltech.edu>, Michael Perreur-Lloyd <m.perreur-lloyd@physics.gla.ac.uk>

**CC:** Caroline Cantley <c.cantley@physics.gla.ac.uk>

Colleagues

Here are results of looking at the various items which Mike and Calum sent on 17th Sept.

1) Revised mass and moment of inertia values for the top mass (from MPL)

~~Mass = 22065 grams~~

~~Moments of inertia: ( grams \* square millimeters )~~

~~Taken at the center of mass and aligned with the output coordinate system.~~

~~I<sub>xx</sub> = 475483250.8321, I<sub>xy</sub> = 38231496.1255, I<sub>xz</sub> = 169849.0225~~

~~I<sub>yx</sub> = 38231496.1255, I<sub>yy</sub> = 70860235.8652, I<sub>yz</sub> = 12822.2864~~

~~I<sub>zx</sub> = 169849.0225, I<sub>zy</sub> = 12822.2864, I<sub>zz</sub> = 476347389.4152~~

I have checked the MATLAB model with the above (noting that I only use the diagonal elements since the MATLAB model is symmetric) and everything is OK. Only discernible difference was in pitch TF and the new numbers are actually slightly better (more pitch isolation) than the dummy mass.

2) Pitch adjust

MPL asked what is the effect of 600g moved 30mm on the top mass.

I find this gives around 23mrad or 1.3 degrees. This seems more than ample.

3) Vert adjust. Calum asked about plus/minus 1.5 kg on top mass in 0.5kg increments.

I checked that effect of adding 0.5 kg is to move test mass downwards by approx 1.1 mm. As I indicated in an earlier e-mail i would be reluctant to remove mass from the top mass - it will reduce the vertical isolation and also reduce the stiffness of that mass, so i suggest we just consider adding mass, and use the library of clamps to go in the opposite direction if needed.

Point to check- if we need finer adjustment of vert overall ( not one chain with respect to other) - I think this could be done by HEPI system.

4) Roll adjust. The MATLAB model is not so accurate at predicting this since we do not model well the addition of angled wires to blades, and this in particular affects one of the roll modes and hence the DC roll behaviour. Mark's Mathematica model is better to use. He predicted 3.6 mrad for 0.6 kg moved 30 mm on the upper intermediate mass. This was for an earlier set of quad parameters but will not be far away from the behaviour of the current model.

I think that's it for now.

Cheers  
Norna

From: Norna Robertson <nornar@stanford.edu>  
To: Michael Perreur-Lloyd <m.perreur-lloyd@physics.gla.ac.uk>  
CC: Caroline Cantley <c.cantley@physics.gla.ac.uk>, ctorrie <ctorrie@ligo.caltech.edu>  
Date: Tue, February 1, 2005 3:00 am  
Subject: Re: Pitch Lever Arm on C-Ptye ETM Top Mass

Mike

I have checked this and as far as I can see reducing the leverarm to 55mm is still OK in overall terms of decay time, and so could be used. However the lowest mode is still a bit ringy at that value and so to be conservative I might suggest not going so far - say root 2 smaller, at 77mm. If 55mm works better in a new mechanical design then that's OK - we can compensate with more electronic gain given that the gains can be uncoupled from each other using digital control.

I checked this for a silica test mass since this is now baseline (but would also be Ok for sapphire).

I first looked at the wrong model - from Nov 03 rather than April 04 - and in that model we wouldnt want to have had such a small lever arm. Things which have changed since then include blade frequencies and overall length - and so this must have made a difference to the pitch behaviour.

Cheers  
Norna

At 03:17 PM 1/27/2005 +0000, Michael Perreur-Lloyd wrote:

>Hi Norna,  
>  
>When you have a chance can you confirm how far the Pitch Magnet-Flag can  
>be moved on the Top Mass. Originally, with earlier speciifcations, this  
>was positioned at 110mm above the Centre of Mass. I think you said that  
>this may be able to move as low as 55mm?!  
>  
>Thanks.  
>Mike P-L.  
>--  
>Michael Perreur-Lloyd,  
>Research Engineer  
>Institute for Gravitational Research,  
>University of Glasgow, Scotland, G12 8QQ.  
>Tel: +44 (0)141 339 8855 ext0099  
>Email: [m.perreur-lloyd@physics.gla.ac.uk](mailto:m.perreur-lloyd@physics.gla.ac.uk)

**Subject:** Re: FW: Fwd: DCN for Top Mass

**From:** Dennis Coyne <coyne@ligo.caltech.edu>

**Date:** Thu, 19 May 2005 08:19:17 -0700

**To:** <m.perreurlloyd@physics.gla.ac.uk>

**CC:** Norna Robertson <nornar@stanford.edu>, "Wilmut, I \ (Ian)" <I.Wilmut@rl.ac.uk>, Calum Torrie <torrie\_c@ligo.caltech.edu>, Janeen Romie <janeen@ligo.caltech.edu>

Mike,

Also:

D040380-A and D040370-A are missing references to the DCN and Drawing tree in the upper right corner of the drawings.

Dennis

At 08:17 AM 5/19/2005, Dennis Coyne wrote:

Mike,

Sorry for the delay in replying. This is a very nice data package. I've signed the DCN (attached).

I have a few comments, below. None of these comments should hold up release of the drawing package.

1) The PDS is a nice design description. BTW I agree that there isn't a need to place it into configuration control with a DCN.

However, in section 2.2, you state: "These requirements and output specifications are shown

in document T0101031 (the numbers have since been updated in document T040214) but to avoid confusion the most up-to-date numbers can be obtained from Norna Robertson."

I think that the basic mass properties and geometric parameters (i.e. matlab model parameters) which are requirements for the design should be put under configuration control. The DCN revision process should then trigger people to consider what implications/consequences result from the changes in the desired mass & geometry properties. Perhaps T040214 should be placed into configuration control? I've copied Norna for comment.

The following comments are nits, or minor points, to be taken into consideration in the future, i.e. don't feel compelled to make changes before releasing the drawings. In fact some may not even be worth fixing in the future. Some simply note that other referenced drawing (apparently) have yet to be released in the configuration control system.

2) PDS, section 2.3:

Change from "A full of these symbols ..." to "A full description of these symbols ..."

3) D040370-A

a) The assembly drawing would be more useful if there were item number balloons identifying each of the piece parts, at least to the first level sub-assembly (though I realize that this might take some considerable effort to accomplish).

b) The file is missing an attached step file.

4) General comments which apply to all drawings:

note 5 reads:

"SCRIBE, ENGRAVE OR STAMP DRAWING PARTNUMBER ..."

However, it does not prohibit dyes or inks. Stamping has two meanings -- mechanically stamped (deformed) or ink stamped. Please revise to explicitly exclude inks.

note 5 also reads:

USE .07" HIGH CHARACTERS.

This should be a minimum of 0.07" -- there is no need to make the lettering/numbering small intentionally.

note 5 also reads:

EXAMPLE: D020188- 001.

This part number MUST include the revision letter. It is also a little confusing to use a different part number than the drawing (though I realize that this is a standard note, so

I guess use of a different number than the actual part number is OK.)

E030350-06 has the following suggested comparable note (well, OK -- I actually improved upon the note and dropped reference to drawing variant or type number):  
SCRIBE, ENGRAVE OR MECHANICALLY STAMP DRAWING (NO INKS OR DYES) PART NUMBER, REVISION ON NOTED SURFACE OF PART FOLLOWED ON THE NEXT LINE WITH A THREE DIGIT SERIAL NUMBER. SERIAL NUMBERS START AT 001 FOR THE FIRST ARTICLE AND PROCEED CONSECUTIVELY. USE .12" HIGH CHARACTERS, UNLESS THE SIZE OF THE PART DICTATES SMALL CHARACTERS. A VIBRATORY TOOL MAY BE USED. EXAMPLE:

D050035-A  
S/N 001

5) Drawing Tree, E050062-A:

- a) D040486-A does not appear. Is this because it is optional?
- b) D040398-A appears as a part under an assembly with the same number. This can't be correct.
- c) The following parts appear on the drawing tree, but not in the DCC:  
D020476-A, D040397-A, D040398-A, D040490-01, D040491-01, D040553-A, D040552-A, D040551-A  
Will these be released by another DCN(s)?

6) There is reference in the PDS to a few Jigs & Tools (e.g. D050590, D050595, D050003, D050117). Will these be released with a different DCN(s)?

At 08:24 AM 4/29/2005, Wilmut, I \ (Ian\ ) wrote:

Hi Dennis,  
Attached is Mikes PDS for the top mass. Once you have reviewed and signed it Mike asks if you could send it on to Linda who can add it to the DCC.

Thanks

Ian

-----Original Message-----

From: Caroline Cantley [<mailto:c.cantley@physics.gla.ac.uk>]  
Sent: 28 April 2005 16:13  
To: Wilmut, I (Ian)  
Cc: Janeen; Michael Perreur-Lloyd; Norna Robertson; Janeen Hazel Romie; [ctorrie@ligo.caltech.edu](mailto:ctorrie@ligo.caltech.edu)  
Subject: Re: Fwd: DCN for Top Mass

Ian  
attached DCN for Mike PL's top mass PDS. Please pass to Dennis once you've reviewed and signed. Please send comments/feedback to MPL.  
thanks  
Caroline

Janeen wrote:

- > Dear Caroline,
- > Attached is the DCN for Mike P-L's Top Mass PDS. He sent along the PDS
- > via e-mail dated April 8th.
- >
- > Dear Mike,
- > I have some comments. First, concerning the DCN, you've noted under
- > ACTION: Attach DCN to Drawings. There is no need to do that as you've
- > made the A rev change on each of the drawings (I looked in the vault.)
- >
- > You only check that box if you are in a real hurry, or you do not have
- > access to the original and cannot change the rev on the actual
- > drawing, so the DCN acts as the change. I believe you can check the
- > incorporate change box.
- >
- > Second, this PDS is a beautifully executed document and really sums up

> months of design decisions. It's a real treat to read. If I can make  
> one for the tablecloth that is a quarter as thorough, I'll be happy.  
>  
> Third, because I'm not one of the authors, I can give you fresh  
> comments. So, here goes.  
> 1. Section 2.3, third line. "...A full of these..." may mean "...A  
> full list of these..."?  
> 2. Section 2.3.4, table. I wonder if you want to write a quick note of  
> what the t-section is (maybe pointers to the Figure 2?), and why it is  
> acceptable that its target values and as-built values are off.  
> 3. Section 3.3, second paragraph, 3rd line. "...flat blade  
> scre4wdriver." may mean "...flat blade screwdriver."  
> 4. Section 3.5, under Rotational Adjuster. I'm confused; you say that  
> it is difficult but then give an example. Is it part of the design or  
> not?  
> 5. Section 3.7, under Tablecloth. I've been using the Tablecloth Assy,  
> D050187, part number. Would it be best if I change this to D040522 and  
> replace the conceptual design in the vault with the finished assembly?  
> Or would you like to keep the conceptual one separate, for a reason?  
> 6. Appendix 1, Table of ANSYS Testing on Top Mass Plate Models. I  
> assume the table entries are estimated and measured plate deflections?  
> Would you like to change the title of the table to include the word  
> deflection?  
>  
> Janeen  
>  
>  
>  
> Norna Robertson wrote:  
>  
>> Janeen  
>>  
>> Please see below and attached-document for signature.  
>>  
>> Cheers  
>> Norna  
>>  
>> -----  
>>  
>> Notes for MPL added by Norna.  
>>  
>> Mike - I checked numbers - all look fine.  
>>  
>> One comment. In Section 3.6 you talk about provision for global  
>> control wires which need to be fastened to top mass. I think you  
>> should make it clear this is for the reaction chain only. This is  
>> repeated at 6.2 and 7.1.  
>>  
>> Something I suggest adding to section 7. It should be checked that  
>> allowed range of pitch adjust used in the current design is also OK  
>> for a silica suspension. The penultimate and test masses in silica  
>> have different moments of inertia to sapphire sized masses.  
>>  
>> A couple of typos  
>> 4.1 line 3 " and attach the top wire.."   
>> 7.2.1 2nd line "..to note that.."   
>>  
>> -----  
>>  
>>  
>>> X-Sieve: CMU Sieve 2.2  
>>> X-Sender: [ctorrie@becrux.ligo.caltech.edu](mailto:ctorrie@becrux.ligo.caltech.edu)  
>>> X-Mailer: QUALCOMM Windows Eudora Version 6.1.0.6  
>>> Date: Fri, 22 Apr 2005 13:21:43 -0700

>>> To: Norna Robertson <[nornar@stanford.edu](mailto:nornar@stanford.edu)>,  
>>> Michael Perreur-Lloyd <[mpolloyd@physics.gla.ac.uk](mailto:mpolloyd@physics.gla.ac.uk)>  
>>> From: ctorrie <[ctorrie@ligo.caltech.edu](mailto:ctorrie@ligo.caltech.edu)>  
>>> Subject: Fwd: DCN for Top Mass  
>>> Cc: Michael Perreur-Lloyd <[mpolloyd@physics.gla.ac.uk](mailto:mpolloyd@physics.gla.ac.uk)>  
>>> X-Spam-Score: undef - Sender Whitelisted ([ctorrie@ligo.caltech.edu](mailto:ctorrie@ligo.caltech.edu):  
>>> Mail from user authenticated via SMTP AUTH allowed always)  
>>> X-Scanned-By: CanIt (www . roaringpenguin . com) on 131.215.115.19  
>>>  
>>> Dear Norna - Mike asked me to pass this on to you, see below for  
>>> requests wrt signature.  
>>>  
>>> Mike - I think after Dennis signs it it should go back to you to  
>>> gather up all of the comments / suggestions before it goes to Linda?  
>>> CALUM's COMMENTS FOR MPL: -  
>>> ECD - what if they were lighter? - would only be 120g lighter for 2  
>>> 4x4 arrays if alt design used, so probably okay!  
>>> SW files - should we also put them on the DCC? - YES magnet arms  
>>> change to counter boar? - can make suggests changes an  
>>> A1 revision.  
>>> Do we need excel version of drawing tree and bill of materials? -  
>>> YES  
>>>  
>>> Cheers, Calum  
>>>  
>>>> Dear all,  
>>>> When you receive this email, please review the attached DCN. All of  
  
>>>> the files for which can be found at the following location:  
>>>> [http://www.physics.gla.ac.uk/~mpolloyd/ALIGO/topmass\\_dcn.html](http://www.physics.gla.ac.uk/~mpolloyd/ALIGO/topmass_dcn.html)  
>>>> (this is also accessible from my personal webpage) Any comments  
>>>> should be added to this email then the signed DCN must be forwarded  
  
>>>> to the following list of people in the order below:  
>>>>  
>>>> Calum Torrie [Cognizant Engineer-US] - review PDS (all); check  
>>>> drawing tree.  
>>>>  
>>>> Norna Robertson [Cognizant Scientist] - Review PDS mass and moment  
>>>> numbers (Sections 2,6&7)  
>>>>  
>>>> Janeen Romie [Project Manager-US] - Review PDS (all)  
>>>>  
>>>> Caroline Cantley [Project Manager-Glasgow] - Review pds + any  
>>>> drawings you wish.  
>>>>  
>>>> Ian Wilmut [Interface Engineer] - Please check PDS wrt blade and  
>>>> Blade wire clamp interface (Section 2,3) and Noise Prototype  
>>>> (Sections 6&7); check appropriate drawings; check drawing tree.  
>>>>  
>>>> Dennis Coyne [SUS Leader] - Review PDS (all)  
>>>>  
>>>> Linda Turner [DCC Release] - Release DCN (E050063-00-K), PDS  
>>>> (T040071-04-K), Drawing Tree (E050062-A-K), All drawings.  
>>>> Thanks. Mike P-L.  
>>>> --  
>>>> Michael Perreur-Lloyd,  
>>>> Research Engineer  
>>>> Institute for Gravitational Research, University of Glasgow,  
>>>> Scotland, G12 8QQ.  
>>>> Tel: +44 (0)141 339 8855 ext0099  
>>>> Email: [m.perreur-lloyd@physics.gla.ac.uk](mailto:m.perreur-lloyd@physics.gla.ac.uk)  
>>>> Web: [www.physics.gla.ac.uk/~mpolloyd/](http://www.physics.gla.ac.uk/~mpolloyd/)  
>>>>  
>>>>  
>>>>  
>>>>  
>>>>  
>>>>