



Discussion: Supply of COILS and ASSOCIATED PARTS FOR THE LASTI CONTROLS PROTOTYPES

Date: 3<sup>rd</sup> November 2003

INTRODUCTION

The following is a summary of what is required in order to fulfill the order for the Local Control OSEM assemblies for the Advanced LIGO Controls Prototype Suspensions at LASTI. This document is intended as a source of discussion for the Weekly SUS Meeting on Tuesday 4<sup>th</sup> November, 2003.

AUTHORS

Mr. Russell Jones
Dr. Calum Torrie

THE ASSEMBLY

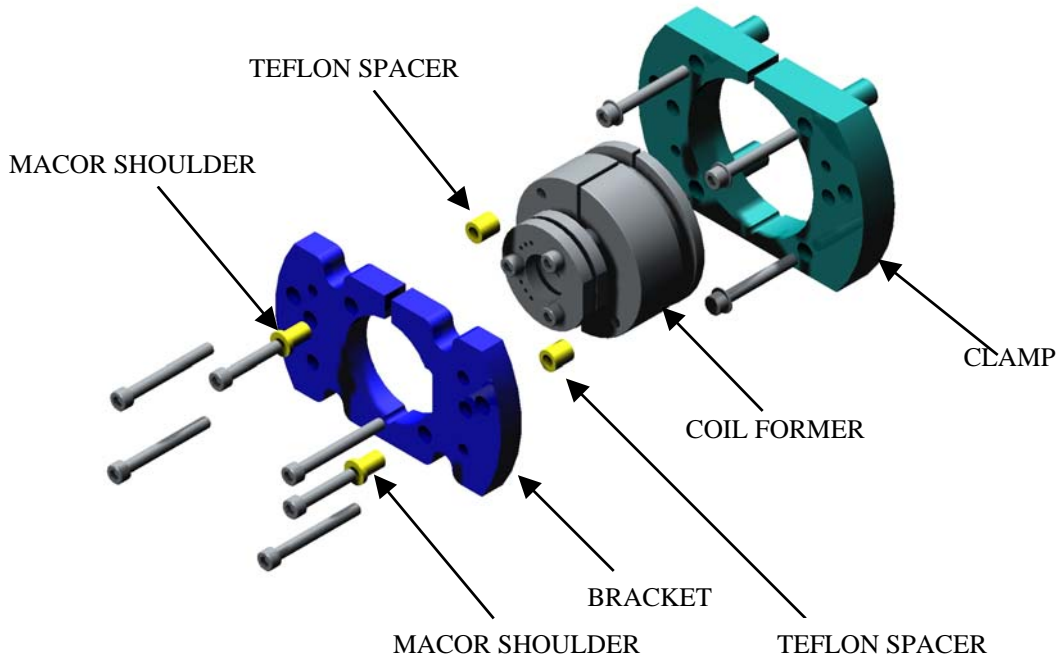

It is important to note that both the BRACKET and the CLAMP used in each assembly must be unique for each suspension, as they incorporate access holes for blade guards and earthquake stops. These holes are in different locations on each suspension.

At the moment, CLAMPS and BRACKETS for the RM, ETM's and 'shelf spares' will all be left without these holes. This means that further machining will be required once the position of these holes is known.

To the right is a rendered view of the COILFORMER CLAMP\_ALT in which the thickness (as indicated in yellow) has been increased. Whether these ALT components are required (and if so, how many?) should be discussed.

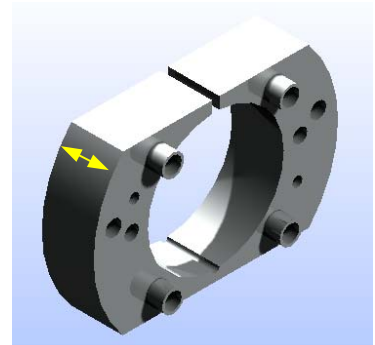

**SUMMARY****Discussion: Supply of COILS and ASSOCIATED PARTS FOR THE LASTI CONTROLS PROTOTYPES****BREAKDOWN OF QUANTITIES: as agreed at ALUK meeting in August 2003****Requirements:**

MC1	<b>9</b>	(6 + 3 spare)
MC2	<b>9</b>	(6 + 3 spare)
RM	<b>9</b>	(6 + 3 spare)
QUAD1	<b>18</b>	(12 + 6 spare)
QUAD2	<b>18</b>	(12 + 6 spare)
Shelf spares	<b>9</b>	
<b>TOTAL assemblies</b>	<b>72</b>	

**IMMINENT ORDER OF MECHANICAL COMPONENTS (GLASGOW)**

	Number	Rev.	Name	Material	Quantity	NOTES
<b>MC</b>						
	D020188***	09	Coil Former	6061-T6-Al	72	Same Coil Former used in all prototypes
	D020282	09	Coil Bracket	6061-T6-Al	18	6 plus 3 spare for both MC1 and MC2
	D030183	03	Coil Clamp	6061-T6-Al	18	6 plus 3 spare for both MC1 and MC2
	D030710	01	Coil Clamp_ALT	6061-T6-Al	18	6 plus 3 spare for both MC1 and MC2
<b>RM</b>						
	D030096	01	Coil Bracket	6061-T6-Al	9	6 plus 3 spare
	D030702	01	Coil Clamp	6061-T6-Al	9	6 plus 3 spare
	D030711	01	Coil Clamp_ALT	6061-T6-Al	9	6 plus 3 spare
<b>ETM</b>						
	D030703	01	Coil Bracket	6061-T6-Al	36	12 plus 6 spare for each quad
	D030704	01	Coil Clamp	6061-T6-Al	36	12 plus 6 spare for each quad
	D030712	01	Coil Clamp_ALT	6061-T6-Al	36	12 plus 6 spare for each quad
<b>SPARES</b>						
	-	-	Coil Bracket	6061-T6-Al	9	-
	-	-	Coil Clamp	6061-T6-Al	9	-
	-	-	Coil Clamp_ALT	6061-T6-Al	9	-

Drawings have now been checked and approved. These drawings be sent out to our preferred suppliers for quotation following the conclusions from the Weekly SUS Meeting on Tuesday 4<sup>th</sup> November, 2003.

Given necessary alterations to the COIL/CLAMP/BACKET drawings (following shorting tests<sup>1</sup> and general feedback) it should be noted that no full (up to date) OSEM assembly has been created thus far. No full assembly has been carried through the Assembly Specification, or the Testing Specification<sup>2</sup>.

<sup>1</sup> LIGO-T030223-00-K: Review of basic shorting tests on COILFORMERS (R.Jones, C.Torrie)

<sup>2</sup> LIGO-E030094-00-D: Hybrid OSEM Testing Specification (J.Romie)



# SUMMARY

## Discussion: Supply of COILS and ASSOCIATED PARTS FOR THE LASTI CONTROLS PROTOTYPES

Therefore it may be wise to cycle the order of the COIL FORMERS (D020188) in particular, for the following reasons:

- To stagger the effort involved in coil/wire preparation at CALTECH
- To test and perfect the use of suggested design enhancements (i.e. Kapton paste/film and alternative wire)

We have currently specified shelf spares at 12.5% of the total requirement, and should discuss whether this is sufficient.

### ENGRAVING

Parts are to be engraved with their individual drawing number, followed by a three digit serial number commencing from 101. (e.g.D020188-101)

	Number	Rev.	Parts to be ENGRAVED with...
	D020188	09	D020188-101 up to D020188-172
<b>MC</b>	D020282	09	D020282-101 up to D020282-118
	D030183	03	D030183-101 up to D030183-118
	D030710	01	D030710-101 up to D030710-118
<b>RM</b>			
	D030096	01	D030096-101 up to D030096-109
	D030702	01	D030702-101 up to D030702-109
	D030711	01	D030711-101 up to D030711-109
<b>ETM</b>			
	D030703	01	D030703-101 up to D030703-136
	D030704	01	D030704-101 up to D030704-136
	D030712	01	D030712-101 up to D030712-136
<b>SPARES</b>			
	-	-	?
	-	-	?
	-	-	?

### FURTHER WORK IN THE US

- 1) Manufacture of TEFLON spacers (D030123) and MACOR shoulders (D030122)

We should discuss whether these parts are still required. It has already been suggested that the spacer be kept to allow the bracket to be offset from the coil head as it provides important clearance for the Kapton coated coil wire.

- 2) Winding

Janeen has located a company in the US that will allow winding duties to be transferred over from the GEO 600 Group in Glasgow to the team at the California Institute for Technology.

**Discussion: Supply of COILS and ASSOCIATED PARTS FOR THE LASTI CONTROLS PROTOTYPES**3) Mounting of LED and PD

This shall remain the responsibility of the team at CALTECH.

4) Wire

Janeen has been looking into alternative wire with a thicker Kapton coating, and may have comments related to this.

5) Kapton paste/sleeves

We should discuss the progress regarding the sourcing and testing of this product.

6) Mechanical Assembly

Cleaning, baking and general mechanical assembly shall be performed at CALTECH.

An Assembly Specification<sup>3</sup> is under construction (author: Helena Armandula).

---

<sup>3</sup> Exxxxxx-00-D Assembly Specification (H. Armandula)