

D1003296_ISC_TransMon_Periscope_Lens_Bracket, PART PDM REV: X-000, DRAWING PDM REV:

NOTES CONTINUED:

5. SCRIBE, ENGRAVE, OR MECHANICALLY STAMP (NO INKS OR DYES) DRAWING PART NUMBER, REVISION (AND VARIANT OR "TYPE" IF APPLICABLE) ON NOTED SURFACE OF PART FOLLOWED ON THE NEXT LINE WITH A THREE DIGIT SERIAL NUMBER. SERIAL NUMBERS START AT 001 FOR THE FIRST ARTICLE AND PROCEED CONSECUTIVELY. USE MINIMUM 0.12" HIGH CHARACTERS, UNLESS THE SIZE OF THE PART DICTATES SMALLER CHARACTERS. A VIBRATORY TOOL MAY BE USED. EXAMPLE: DXXXXXX-VY, TYPE-XX, S/N XXX

6. APPROXIMATE WEIGHT = X.XXX LB.

7. MACHINE ALL SURFACES TO REMOVE OXIDES AND MILL FINISH. USE OF ABRASIVE REMOVAL TECHNIQUES IS NOT ALLOWED.

8. ALL PARTS SHALL BE MANUFACTURED IN ACCORDANCE WITH LIGO SPECIFICATION E0900364.

9. ALL HELI-COIL HOLES TO BE PREPARED ACCORDING TO EMHART HELI-COIL PRODUCT CATALOG, HC2000, REV 4

10. ALL HELI-COIL INSERTS TO BE INSTALLED BY LIGO PERSONNEL. AFTER DELIVERY OF FINISHED PARTS, USE NITRONIC 60 THREADED INSERTS.

11. ALL MATERIAL IS TO BE VIRGIN MATERIAL (i.e. NOT WELD REPAIRS OR PLUGS UNLESS APPROVED IN ADVANCE IN WRITING BY LIGO, REFER TO LIGO-E0900364.

12. NO REPAIRS SHALL BE MADE UNLESS APPROVED IN ADVANCE, AND IN WRITING, BY LIGO LABORATORY. IN GENERAL WELD REPAIRS AND PRESS FIT INSERT REPAIRS ARE NEVER ACCEPTABLE. THE MATERIAL SHOULD BE MADE WITH VIRGIN MATERIAL. SPECIAL CIRCUMSTANCES CAN BE REVIEWED IF / WHEN BROUGHT TO THE ATTENTION OF LIGO CONTRACTING OFFICER'S REPRESENTATIVE (COTR) THROUGH A MATERIAL REVIEW BOARD (MRB) PROCESS, REFER TO LIGO-E0900364.

B			
	.003		
	.003	A	C

C			
	.003		
	.003	A	B

REV.	DATE	DCN #	DRAWING TREE #
-	-	-	-
-	-	-	-
-	-	-	-

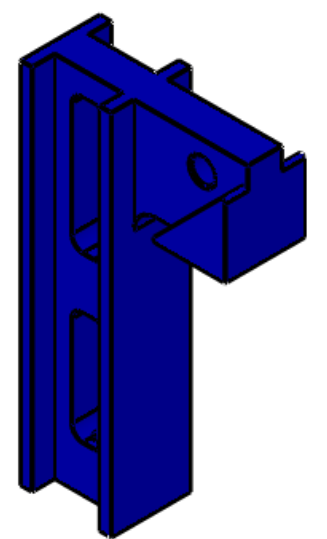

∅ .266 ∇ .375

✓ ∅ .300 X 90°, NEAR SIDE

✓ ∅ .300 X 90°, FAR SIDE

	.010	C	A	B
--	------	---	---	---

A			
	.003		
	.003	B	C

∅ .201 ∇ .500

1/4-20 UNC ∇ .500

	.010	A	B	C
--	------	---	---	---

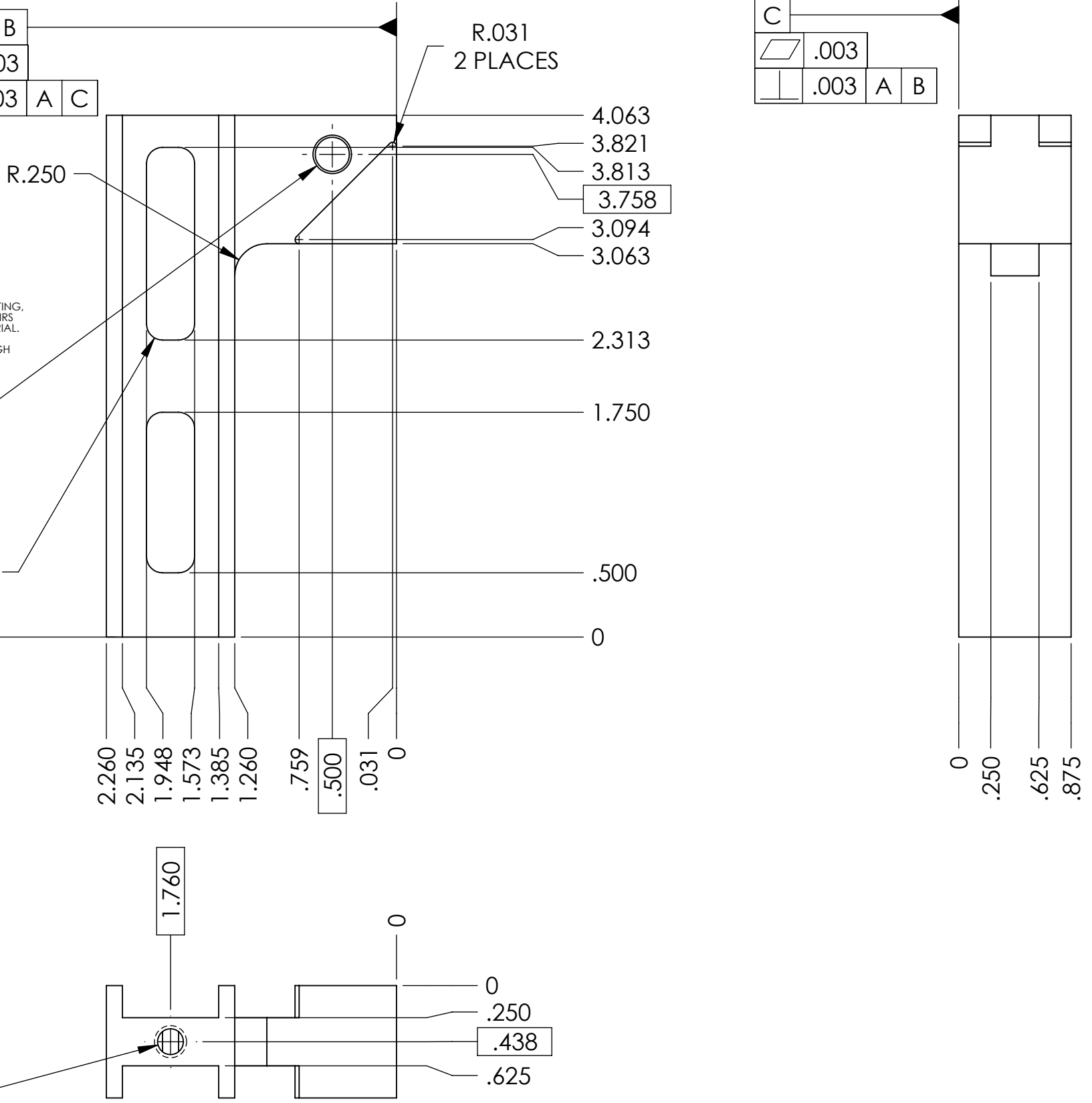

DIMENSIONS ARE IN INCHES	
TOLERANCES:	.XX \pm .01
	.XXX \pm .005
ANGULAR	\pm 0.5°

LIGO CALIFORNIA INSTITUTE OF TECHNOLOGY MASSACHUSETTS INSTITUTE OF TECHNOLOGY	SYSTEM ADVANCED LIGO	SUB-SYSTEM ISC
MATERIAL 6061-T6 Al	FINISH 63 μ inch	NEXT ASSY

PART NAME ISC - TransMon Periscope Lens Bracket		DESIGNER J. FISHER	DATE 15 DEC 2010	SIZE B	DWG. NO. D1003296	REV. v1
DRAFTER J. FISHER	DATE 15 DEC 2010	CHECKER	APPROVAL	SCALE 1:1	PROJECTION	SHEET 1 OF 1