

REV.	DATE	DCN #	DRAWING TREE #
v2	29 DEC 2012	E1000360	-
v3	28 MAY 2013	E1000360-v6	-
v4	11 JUL 2013	-	-

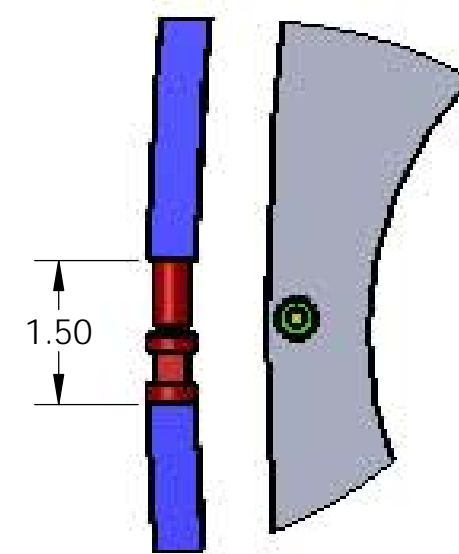

DETAIL A  
SCALE 1 : 2

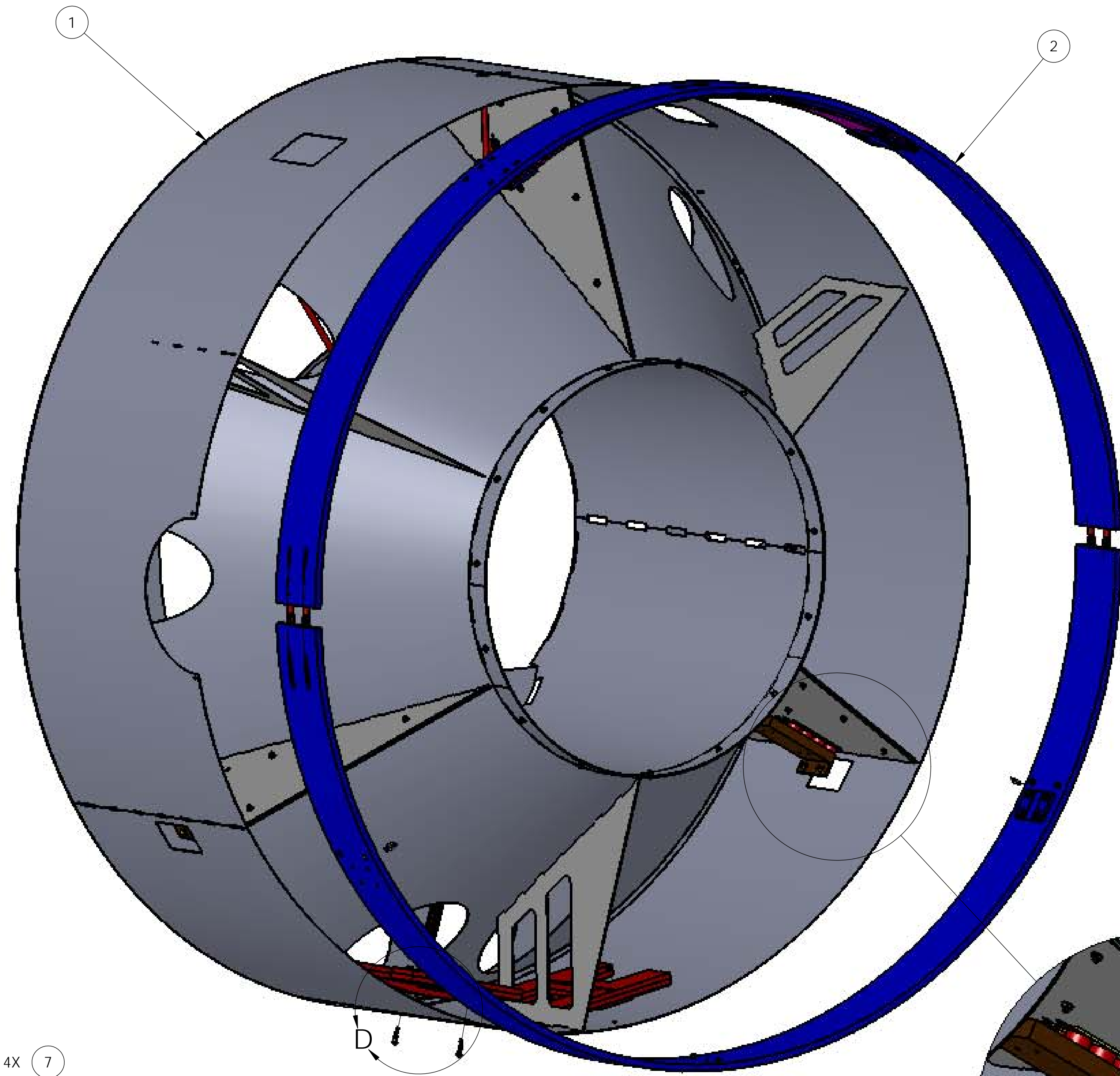
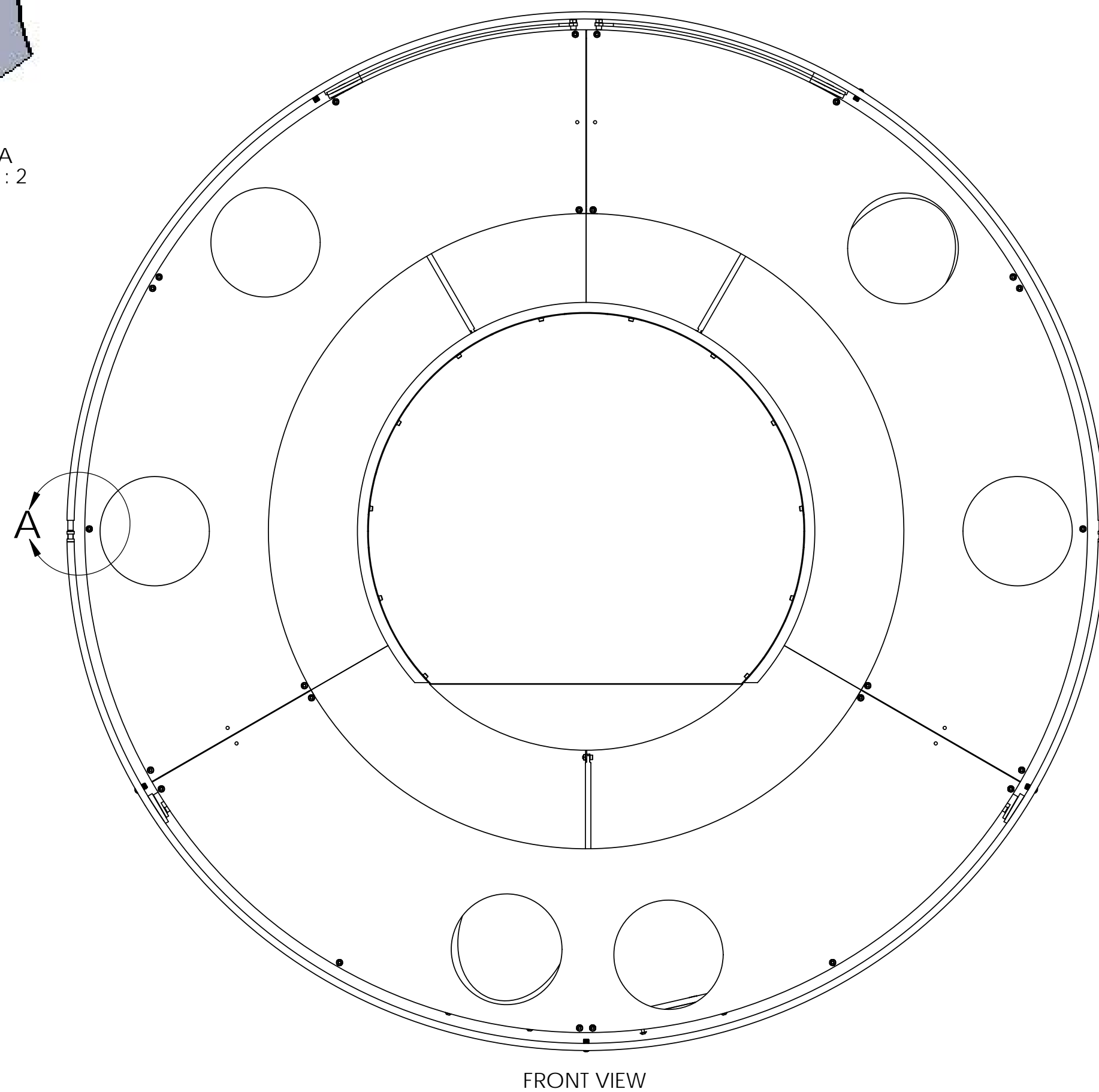

FRONT VIEW

SIDE VIEW

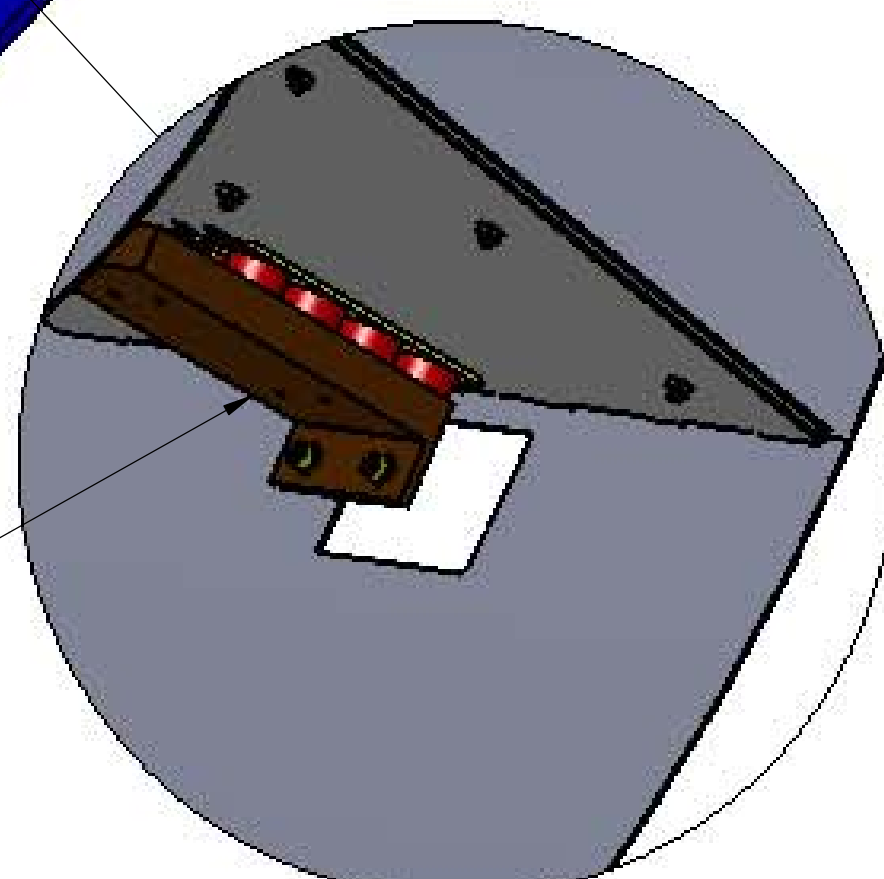

DETAIL B  
SCALE 1 : 3

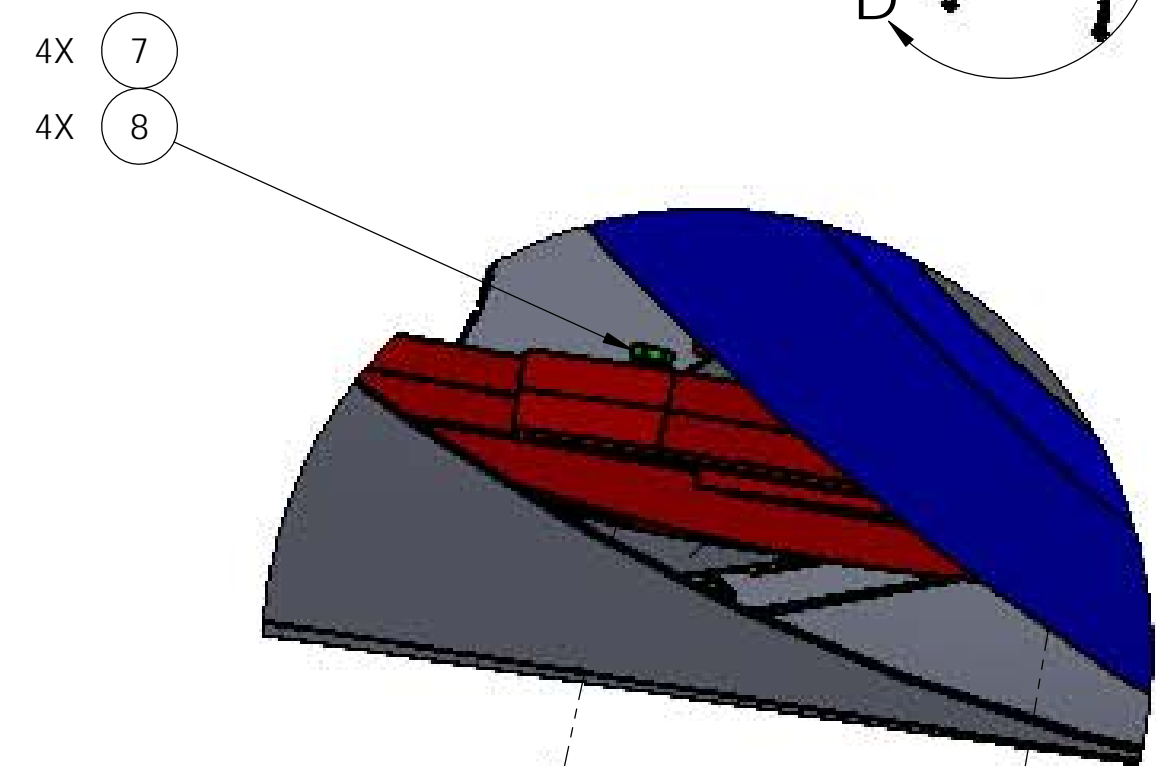

DETAIL D  
SCALE 1 : 2

- 5
- 2X 11
- 2X 9
- 4X 12

- 10 4X
- 7 4X

ITEM NO.	PART NUMBER	DESCRIPTION	MATERIAL	QTY	TOTAL
12	V1156 2-116	VITON O-RING	VITON	8	0
11	C-2008-N	SOCKET HEAD CAP SCREW, SHC, 1/4-20 x 1/2" L	18-8 SSSL	4	0
10	BU-1016-N	BUTON HEAD SOCKET CAP SCREW, #10-32 x 1" L	18-8 SSSL	4	0
9	WF-25	FLAT WASHER 1/4 SCREW SIZE	18-8 SSSL	8	0
8	N-1032-A	HEX NUT, 10-32 THRD SIZE	Ag-PLATED 300 SSSL	4	0
7	WF-10	FLAT WASHER, #10 SCREW SIZE	18-8 SSSL	8	0
6	N-2520-A	HEX NUT, 1/4-20 THRD SIZE	Ag-PLATED 300 SSSL	4	0
5	D1100821	LOWER COPPER PLATE	COPPER	2	0
4	D1001970	SUSPENSION ROD	304, 316 OR 302 SSSL	2	0
3	D1002402	BALANCE WEIGHT ASSEMBLY	N/A	2	0
2	D1002084	OUTER RING ASSY	N/A	1	0
1	D1003183	MANIFOLD-CRYOPUMP BAFFLE RADIAL SEGMENT ASSY, ETMX X	N/A	1	0

NOTES AND TOLERANCES: (UNLESS OTHERWISE SPECIFIED)	
1. INTERPRET DRAWING PER ASME Y14.5-1994.	
2. REMOVE ALL SHARP EDGES, .005-.015. FOR MACHINED PARTS. ROUND ALL EDGES APPROXIMATELY R.02 FOR SHEET METAL PARTS.	
3. DO NOT SCALE FROM DRAWING.	
4. ALL MACHINING FLUIDS MUST BE FULLY SYNTHETIC, FULLY WATER SOLUBLE AND FREE OF SULFUR, SILICONE, AND CHLORINE.	
DIMENSIONS ARE IN INCHES	
TOLERANCES:	
.XX ± .06	
.XXX ± .010	
ANGULAR ± 0.5°	
MATERIAL	N/A
FINISH	N/A μinch

LIGO CALIFORNIA INSTITUTE OF TECHNOLOGY MASSACHUSETTS INSTITUTE OF TECHNOLOGY		PART NAME	
ADVANCED LIGO		MANIFOLD CRYO BAFFLE ASSY, ETMX H1	
DESIGNER	TQ. NGUYEN	11 DEC 2010	SIZE
DRAFTER	TQ. NGUYEN	13 DEC 2010	DWG. NO.
CHECKER	M. SMITH		D
APPROVAL	D. COYNE		D1003181
		SCALE: 1:8	PROJECTION:
			SHEET 1 OF 5

D1003183: alicd.Manifold\_Cryo\_Baffle\_Assembly\_ETMX.H1\_PART\_PDM\_REV\_X:040\_DRAWING\_PDM\_REV\_X:018

INSERT SUSPENSION ROD AND SECURE IT WITH WASHER & NUT BEFORE BRING BAFFLE IN TO MOUNT ON SUSPENDED SPRING PLATES.

- 2X (4)
- 2X (10)
- 2X (6)

DETAIL F  
SCALE 1 : 2

DETAIL G  
SCALE 1 : 3

SECTION J-J  
SCALE 1 : 4

SECTION H-H  
SCALE 1 : 6

- 2X (3)
- 2X (8)
- 4X (7)
- 2X (9)

DETAIL K  
SCALE 1 : 3

<b>LIGO</b> CALIFORNIA INSTITUTE OF TECHNOLOGY MASSACHUSETTS INSTITUTE OF TECHNOLOGY	
SIZE DWG. NO.	REV.
<b>D</b> <b>D1003181</b>	<b>v4</b>
SCALE: 1:8	PROJECTION:  SHEET 2 OF 5

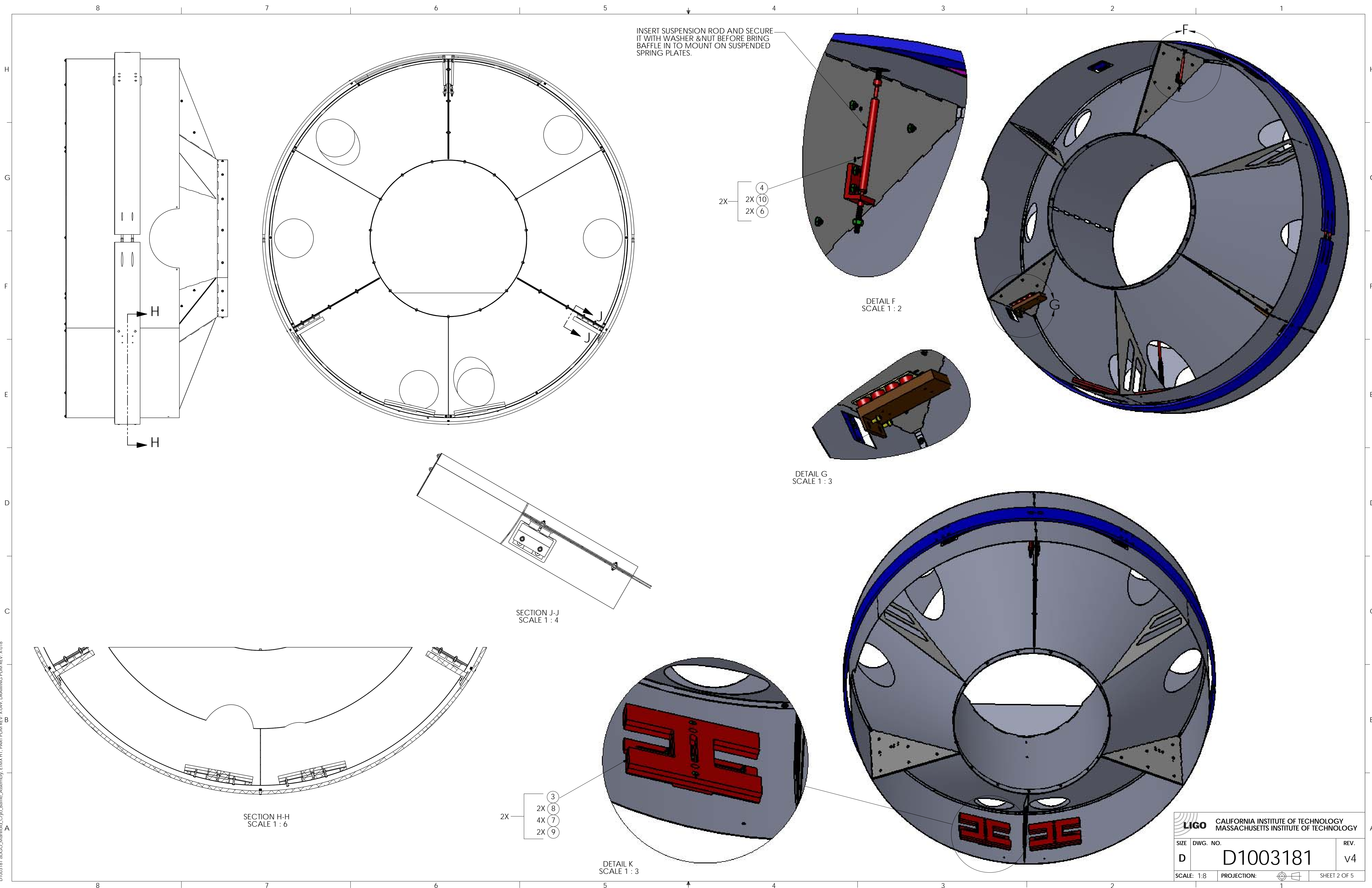

D1003181 alUCO\_Manifold\_Cryo\_Baffle\_Assembly\_ETMX.HI\_PART\_PDM\_REV\_X.040\_DRAWING\_PDM\_REV\_X.018

**INSTALLATION OF MANIFOLD CRYOPUMP BAFFLE INTO A-7 ADAPTER (LHO & LLO X-END STATION)**

**1) PARTIAL VE LAYOUT (LHO & LLO X-END STATION)**

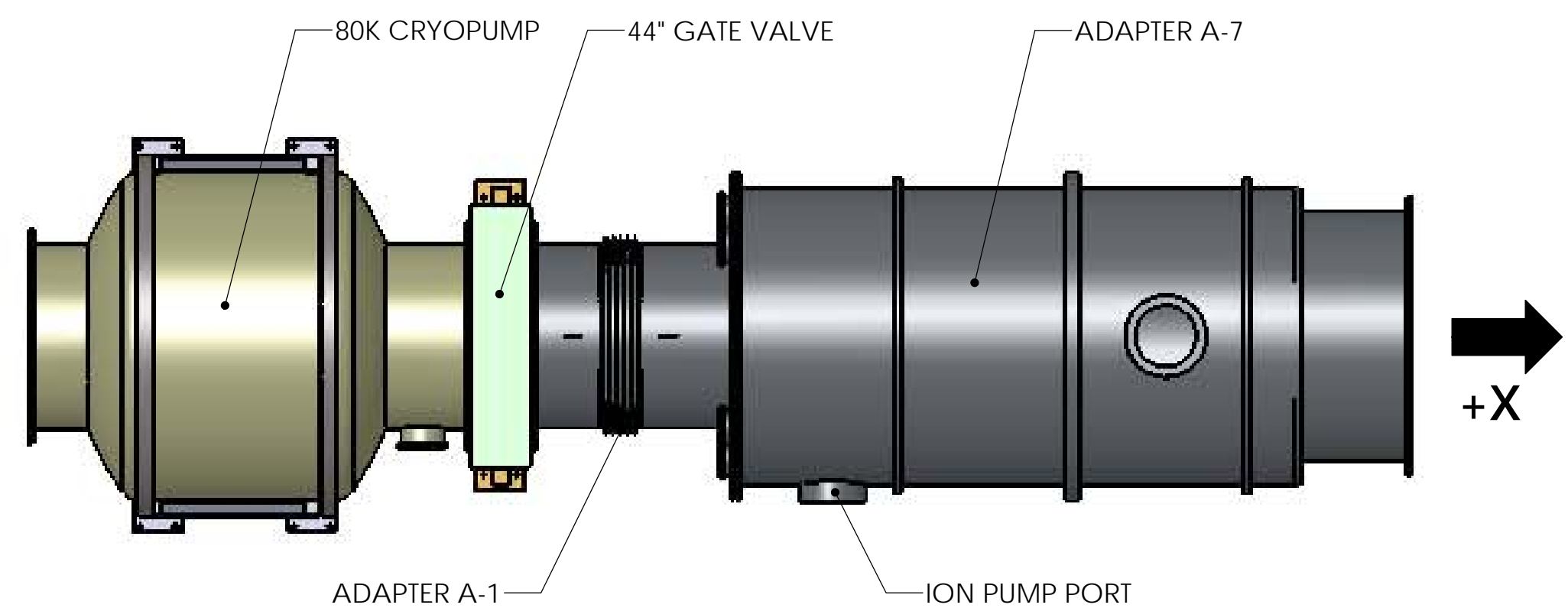

**3) INSTALL FLANGE PROTECTOR & ALIGNMENT TOOLING AT A-7 ADAPTER**

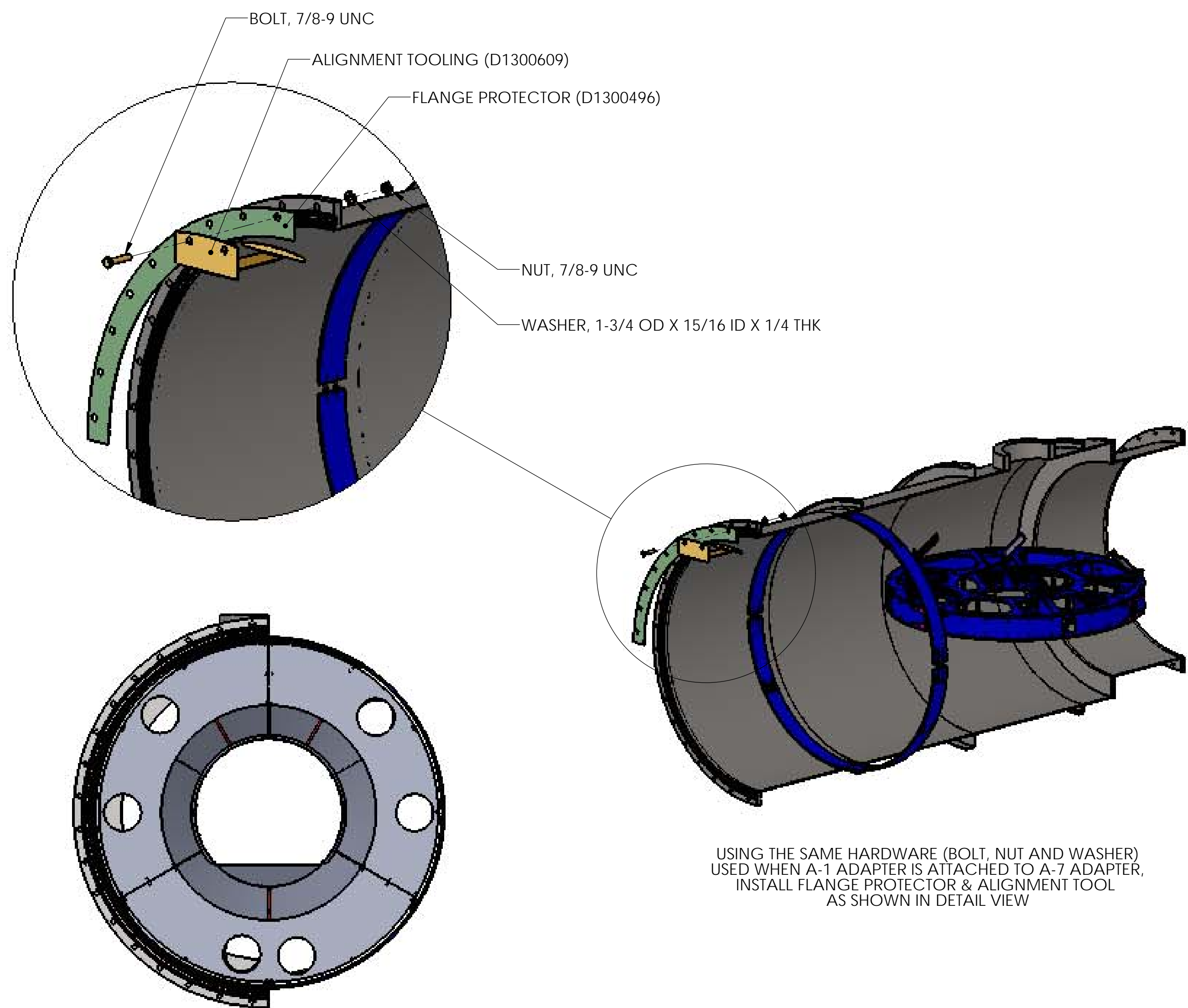

INSTALL 4X FLANGE PROTECTOR (D1300496) & ALIGNMENT TOOLING (D1300609) EQUALLY SPACED AT 90° AS SHOWN

**2) REMOVE A-1 ADAPTER**

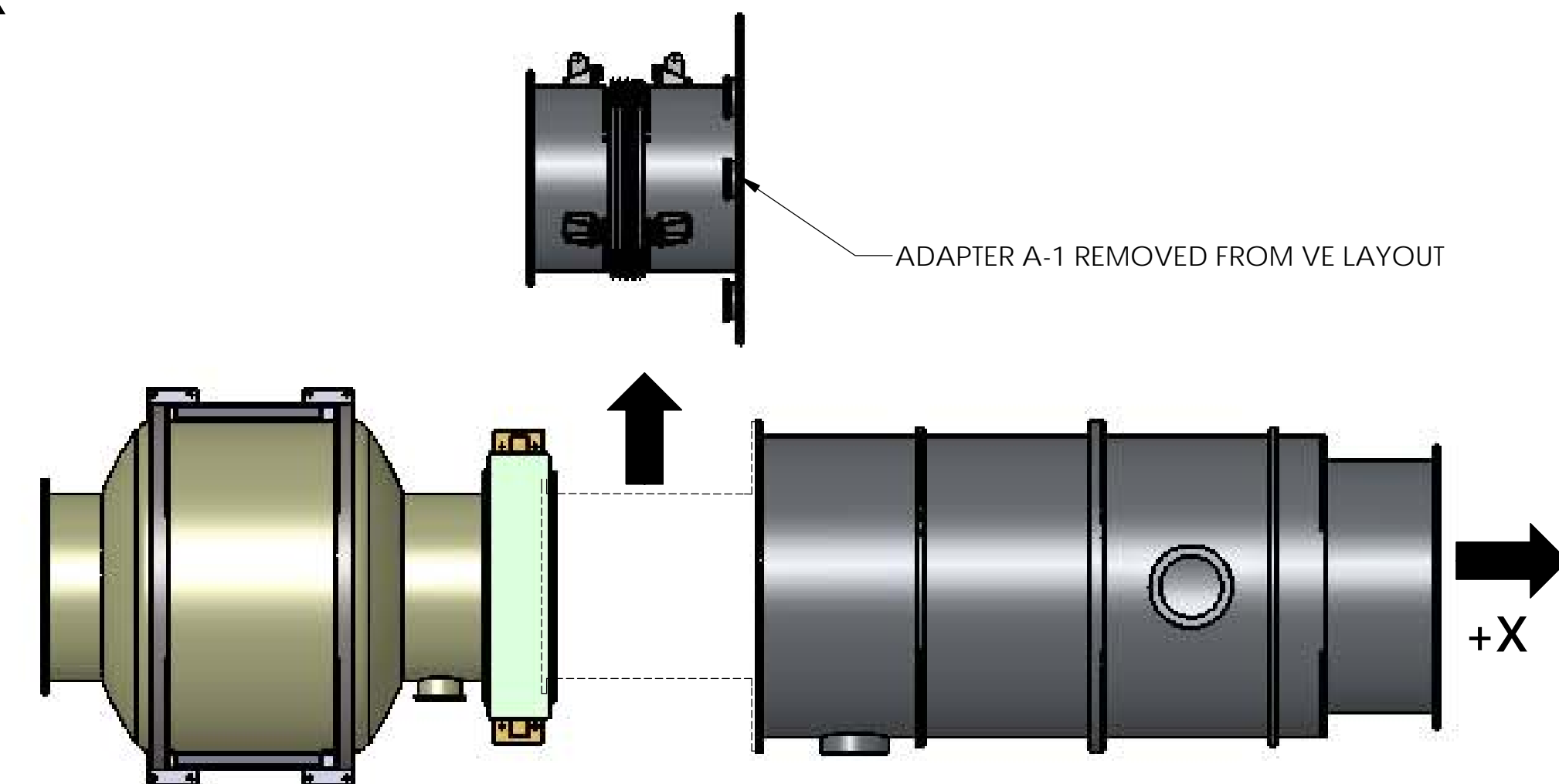

**4) INSERT PCAL-VIDEO CAM PERISCOPE INSIDE A-7 ADAPTER**

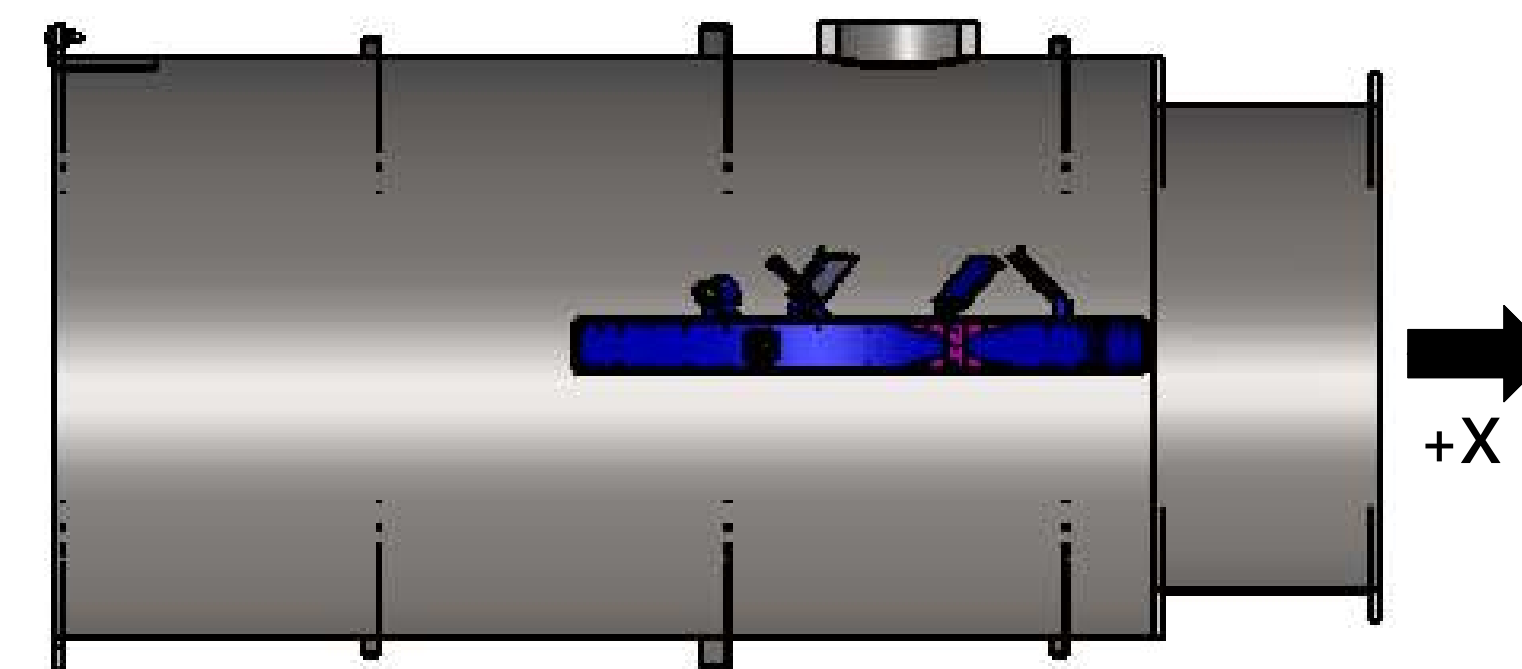

INSERT PCAL-VIDEO CAM PERISCOPE INSIDE A-7 ADAPTER FAR ENOUGH TO HAVE ROOM TO INSERT CRYOPUMP BAFFLE. LAID IT DOWN HORIZONTALLY TO ALLOW ACCESS OF PERSONNEL ENTERING FROM BSC CHAMBER TO WALK TO THE OPENING OF A-7 ADAPTER AND ASSIST IN THE INSTALLATION OF BAFFLE. (FINAL POSITION OF PCAL WILL BE DEFINED AFTER FINAL LOCATION OF CRYOPUMP BAFFLE)

**5) INSERT SUPPORT RING ASSEMBLY (D1002084) INSIDE A-7 ADAPTER**

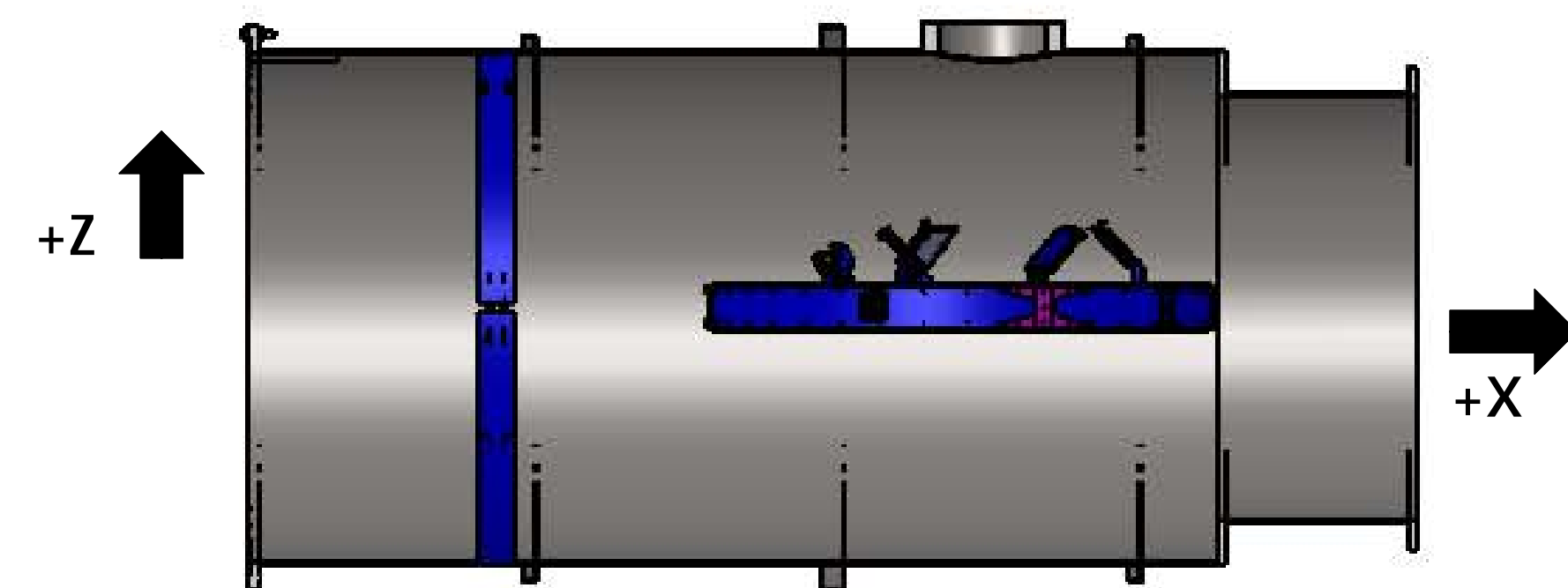

INSERT SUPPORT RING ASSEMBLY (D1002084) INTO A-7 ADAPTER FAR ENOUGH TO HAVE ROOM TO INSTALL THE ALIGNMENT TOOLING TO POSITION THE CRYO BAFFLE AT THE FINAL LOCATION.

NOTE:  
- THE BEVELED SIDE OF THE SUPPORT RING MUST FACE TOWARD THE EMTX

<b>LIGO</b> CALIFORNIA INSTITUTE OF TECHNOLOGY MASSACHUSETTS INSTITUTE OF TECHNOLOGY		REV.
SIZE	DWG. NO.	v4
D		
SCALE: 1:48	PROJECTION:	SHEET 3 OF 5

D:\003181\aligo\_Manifold\_Cryo\_Baffle\_Assembly\_ETMX.HI\_PART\_PDM\_REV\_X.006\_DRAWING\_PDM\_REV\_X.018

6) INSTALL PLUMB BOB ALIGNMENT ASSEMBLY (D1102170).

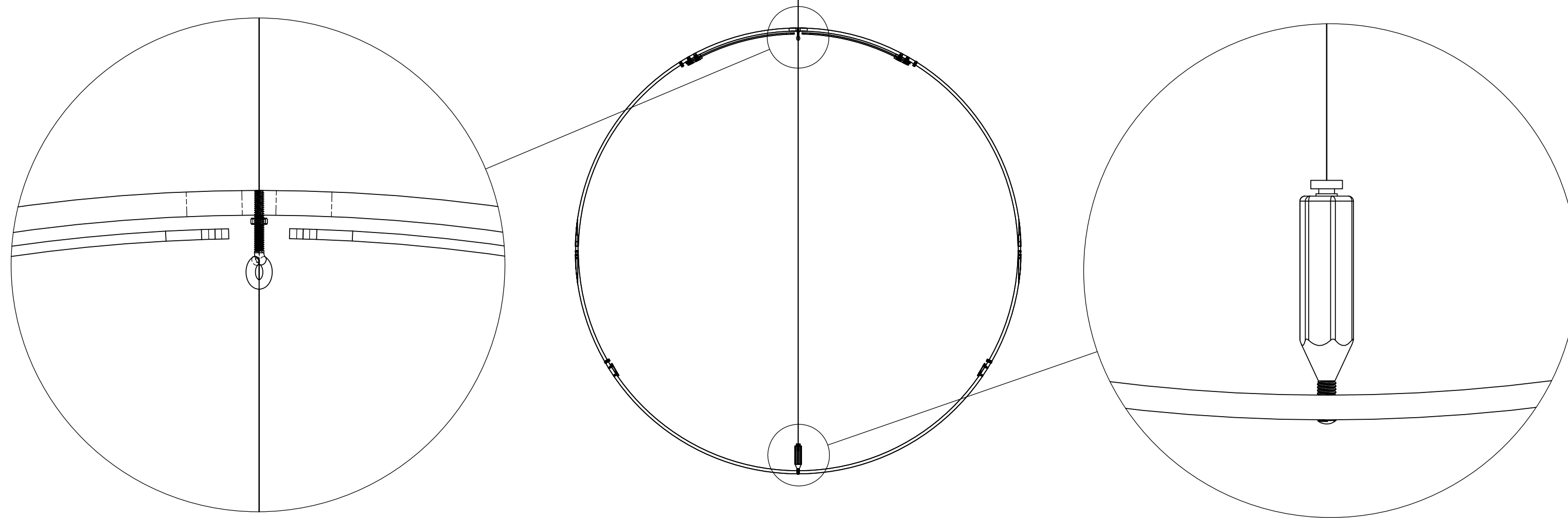

ATTACH THE PLUMB BOB ASSEMBLY FROM THE 10-32 TAPPED HOLE AT THE CENTER OF THE TOP RING

HANG DOWN PLUMB BOB ASSEMBLY TO JUST ABOVE THE 0.25" CLEARANCE HOLE AT THE CENTER OF THE BOTTOM RING.

7) DEFINE LOCATION OF SUPPORT RING ASSEMBLY

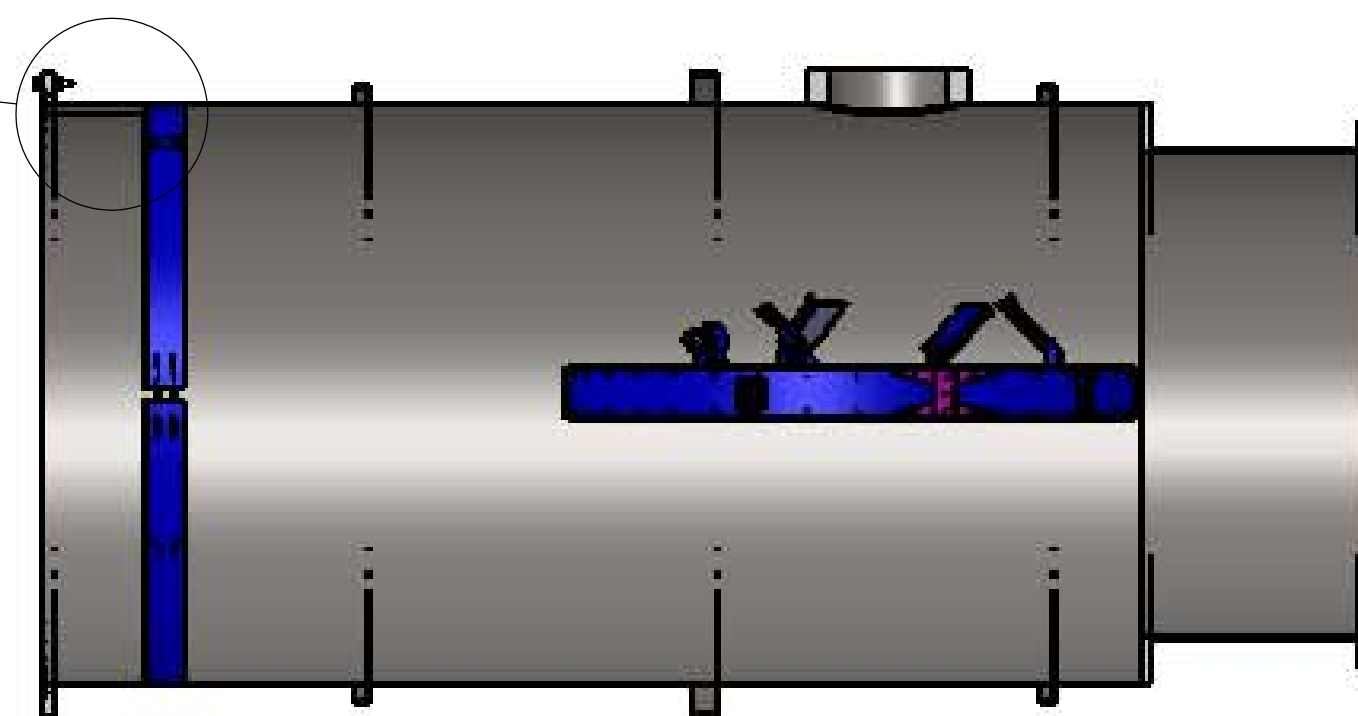
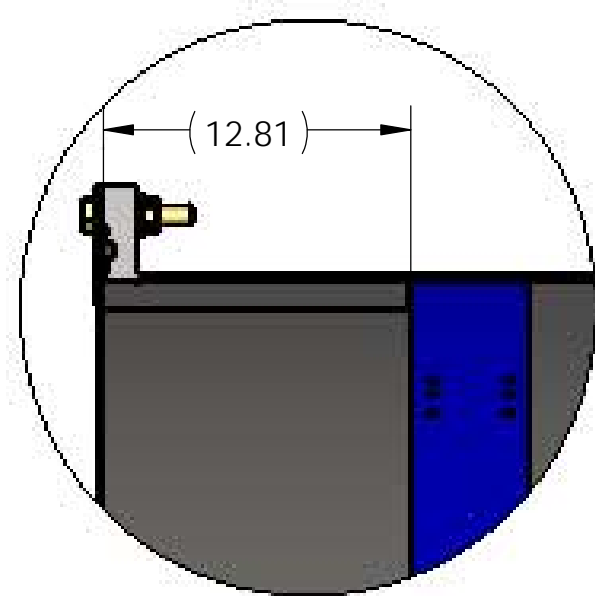

ONCE THE PLUMB BOB ASSEMBLY IS INSTALLED, CLOCK THE RING ASSEMBLY SO THAT THE PLUMB BOB POINTS TO THE CENTER OF THE HOLE.

MOVE THE RING ASSEMBLY UNTIL THE FACE OF THE RING ASSEMBLY IS COINCIDENT WITH THE FACE OF THE ALIGNMENT TOOLING.

NOTE: DOUBLE CHECK THE DISTANCE BETWEEN THE FACE OF THE FLANGE AND THE FACE OF THE SUPPORT RING ASSEMBLY IS 12.81"

8) SECURE THE SUPPORT RING ASSEMBLY

TUMBUCKLE SCREW (D1000778)

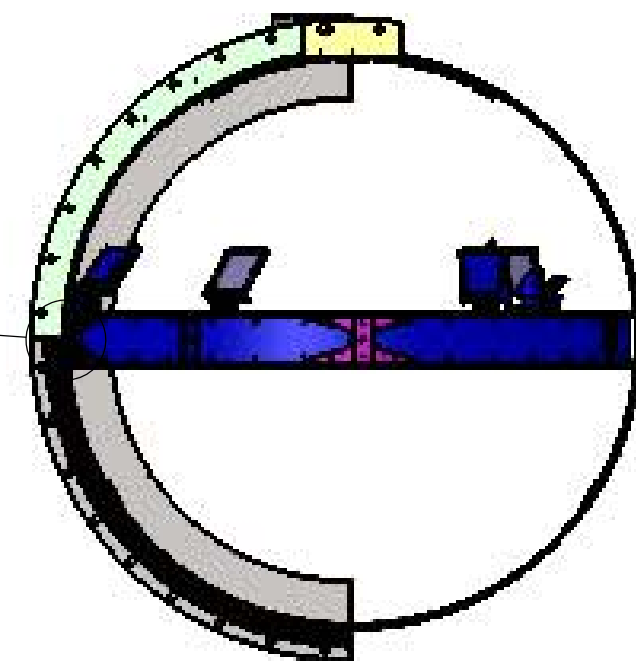
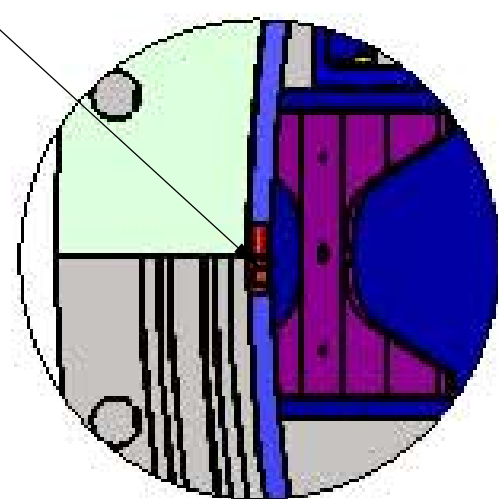

ONCE THE LOCATION OF THE RING ASSEMBLY IS DEFINED, SECURE IT AGAINST THE INSIDE OF THE A-7 ADAPTER BY TIGHTENING THE TUMBUCKLE SCREWS.

9) COMPLETE INSTALLATION OF THE MANIFOLD CRYOPUMP BAFFLE ASSEMBLY

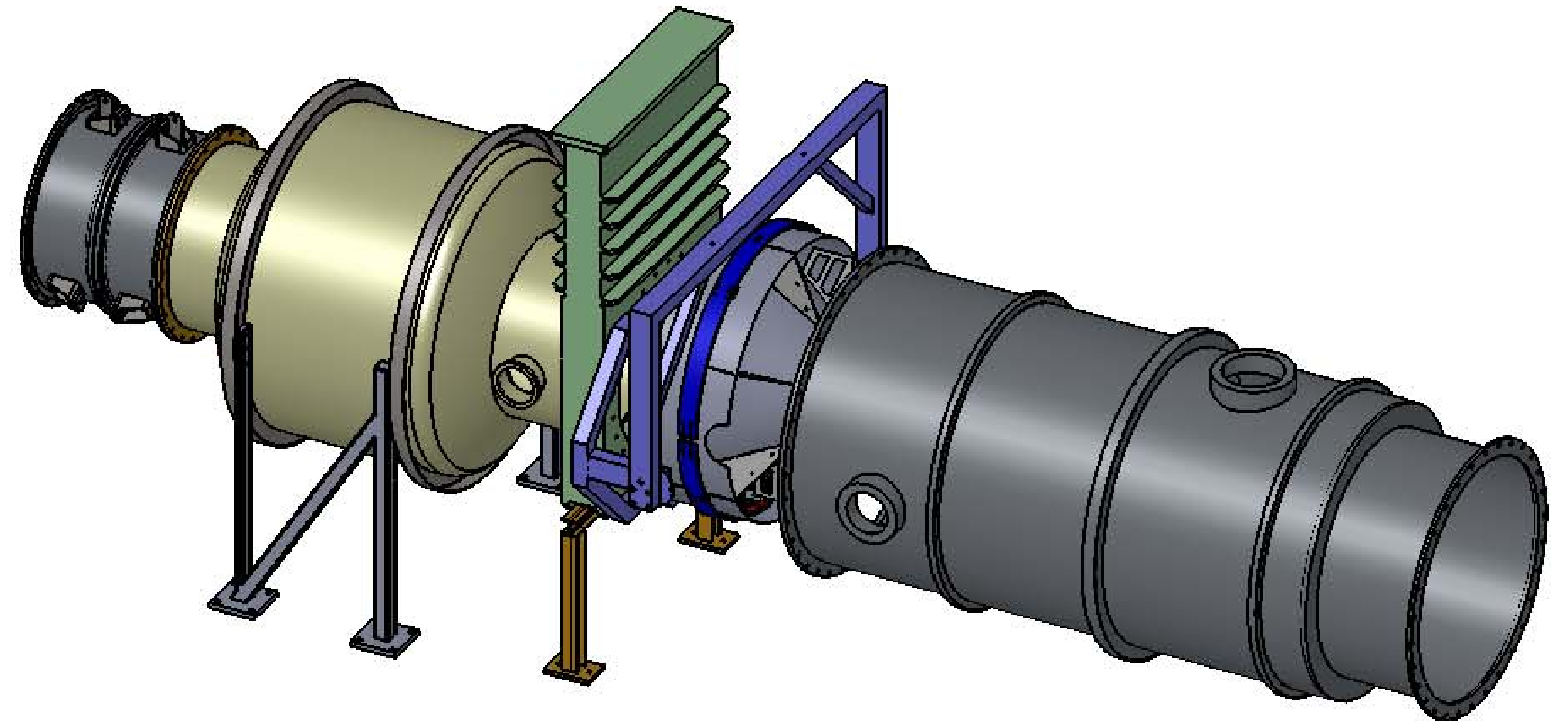

- ATTACH THE LIFT FIXTURE ASSEMBLY TO AN OVERHEAD LIFTING CRANE BY MEANS OF LIFTING STRAPS.

- MAKE SURE THE CUTOUT IN CRYOPUMP BAFFLE IS IN THE SAME SIDE AS THE ION PUMP PORT

NOTE:  
FOR A DETAILED INSTALLATION PROCEDURE OF THE MANIFOLD CRYOPUMP BAFFLE REFER TO INSTALLATION DOCUMENT E1300577.

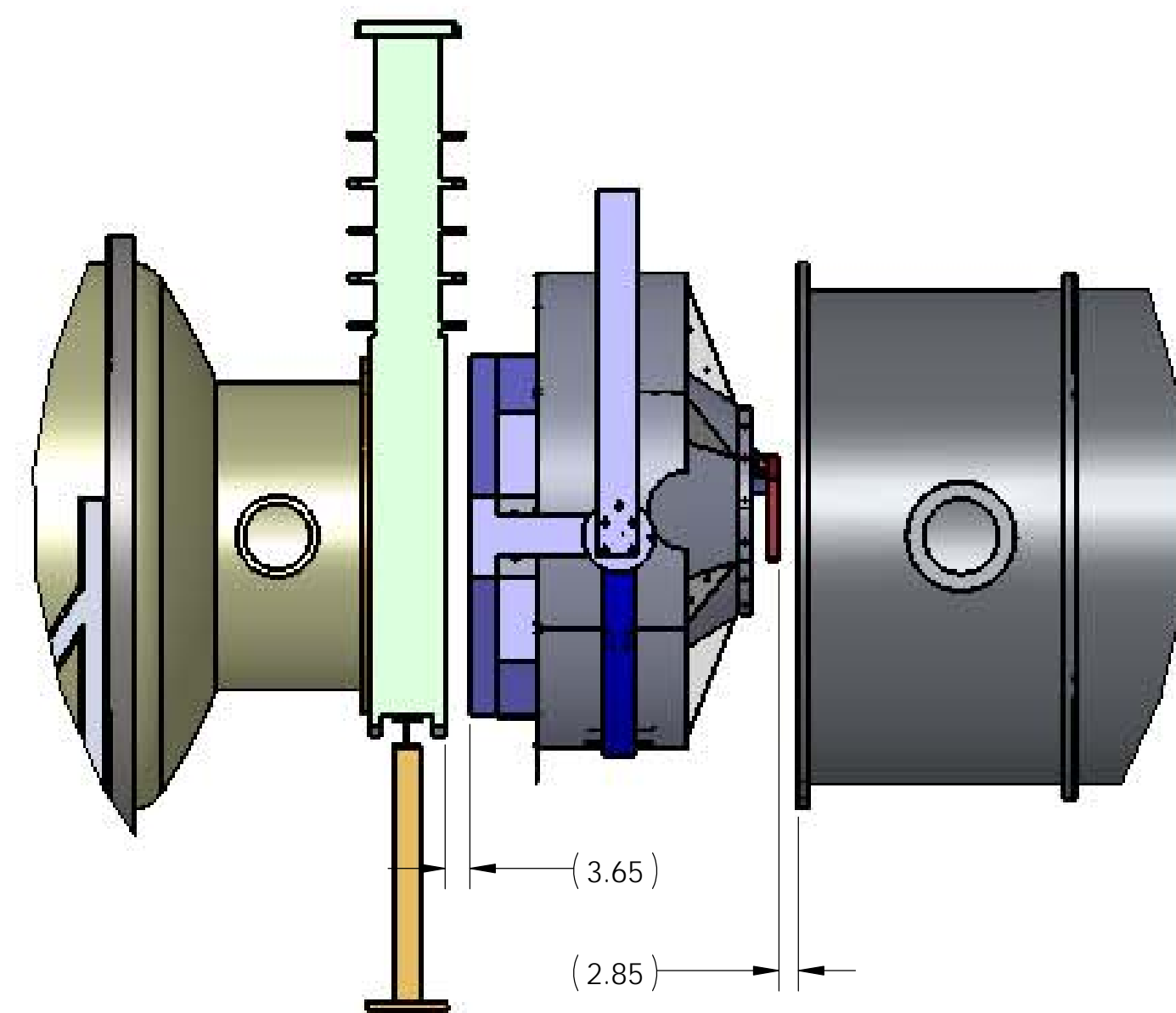

- THERE IS A CLEARANCE OF ABOUT 6.5" BETWEEN THE GATE VALVE AND THE A-7 ADAPTER. TO MANIPULATE THE LIFT FIXTURE WITH THE CRYOPUMP BAFFLE ASSEMBLY.

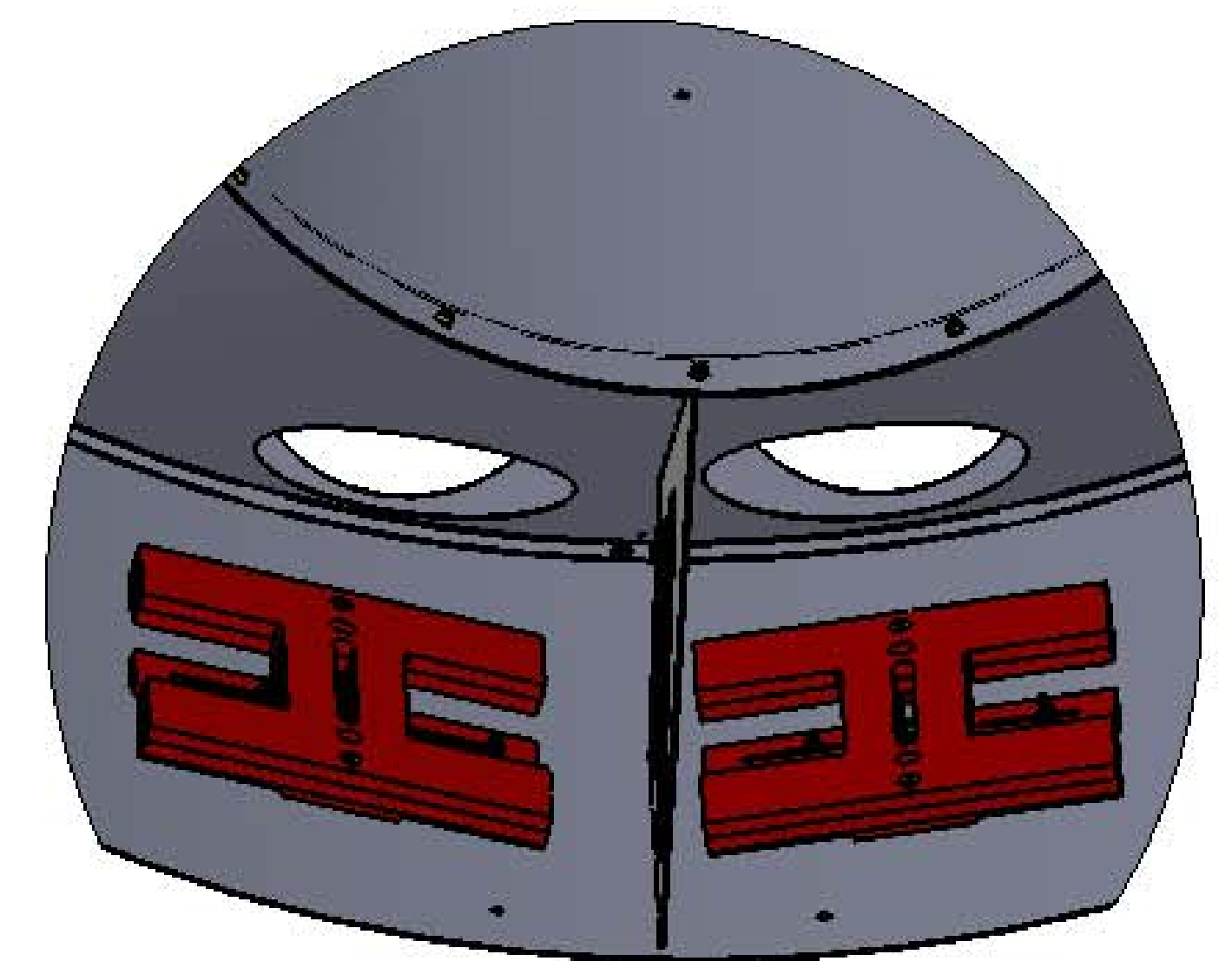

- MAKE SURE THE BALANCE WEIGHT ASSEMBLY (D1002402) IS AT THE CORRECT ORIENTATION OF THE ARROWS.

10) CRYOPUMP BAFFLE FINAL LOCATION INSIDE A-7 ADAPTER AT LHO & LLO X-END STATION

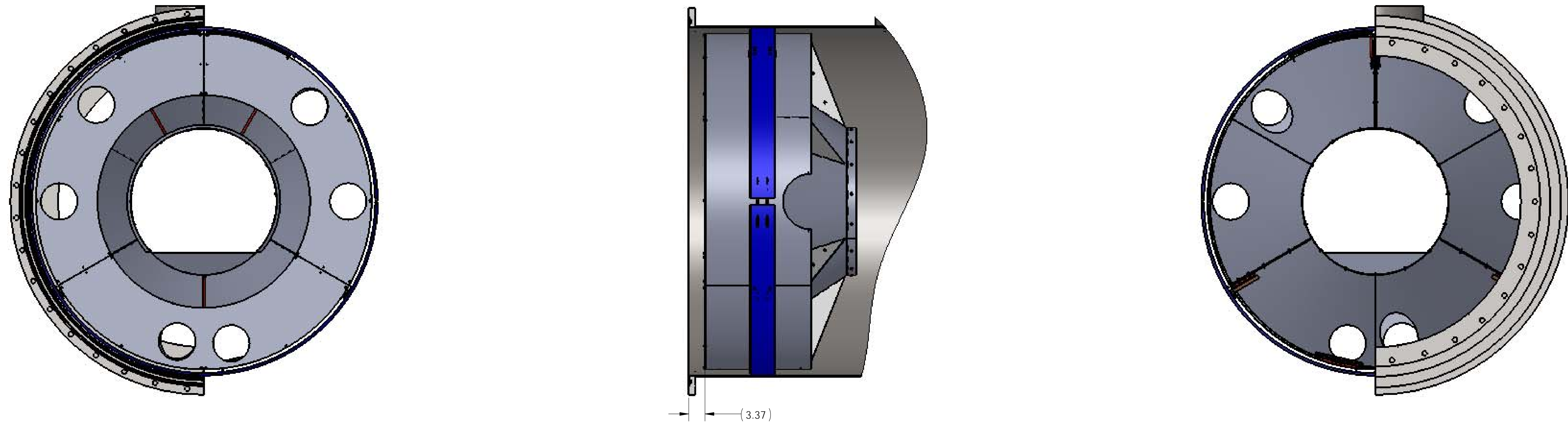

11) TOP VIEW WITH CRYOPUMP BAFFLE FINAL LOCATION AT LHO & LLO X-END STATION

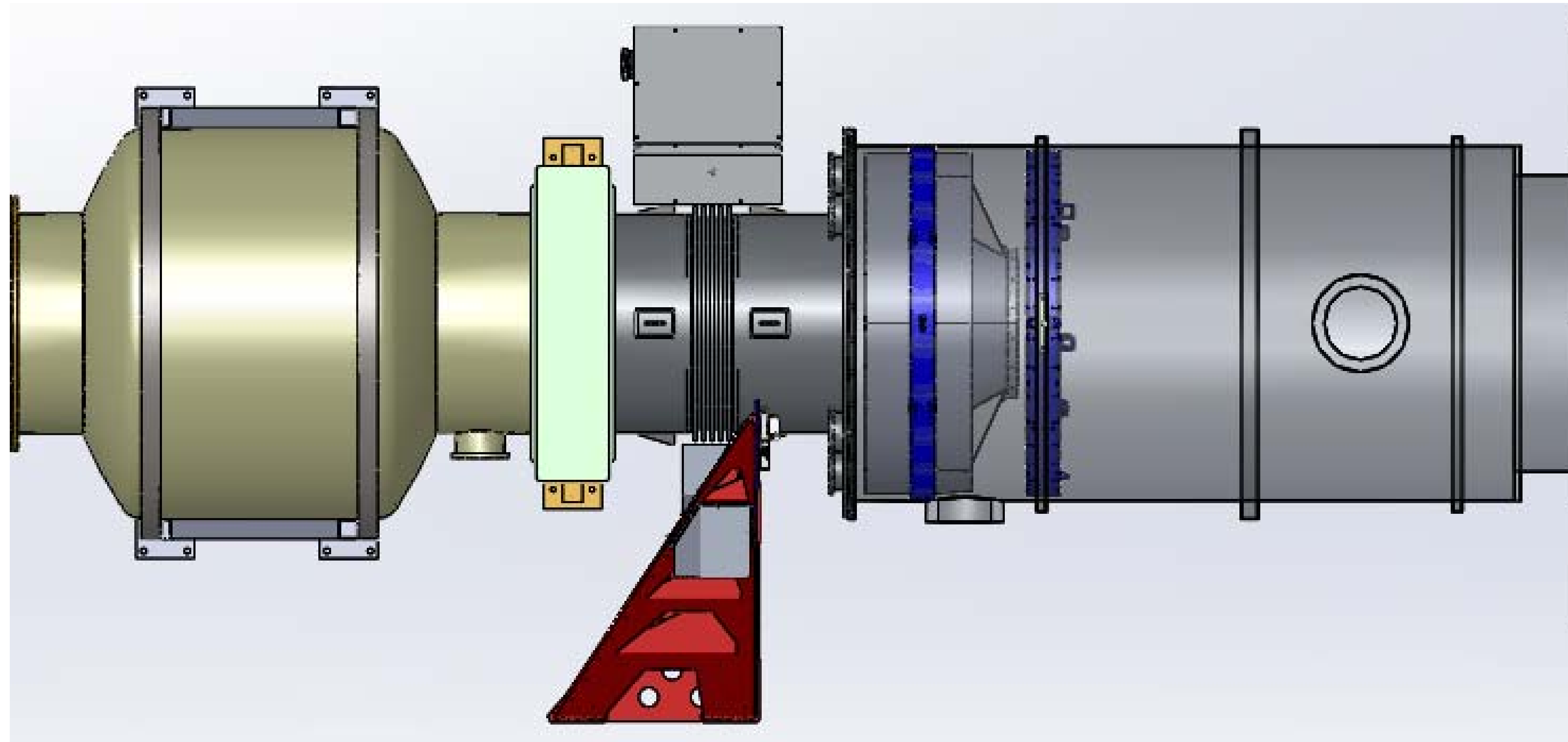

D1003181 aLIGO\_Merfield\_Cryo\_Baffle\_Assembly\_ETMX.H1\_PART\_PDM\_REV\_X.040\_DRAWING\_PDM\_REV\_X.018