

NOTES: (UNLESS OTHERWISE SPECIFIED)

- MATERIAL:**
 - J1 CONNECTOR SHELL - PEEK VICTREX 450GL30
 - J2 CONNECTOR SHELL - SELECTIVELY METALIZED OVER PEEK VICTREX 450GL30.
 - BACKSHELLS - STAINLESS STEEL WITH VENT HOLE.
 - CONTACTS - BERYLLIUM COPPER ALLOY C17300
0.000050 MIN. GOLD OVER NICKEL
 - HARDWARE: CORROSION RESISTANCE STEEL, PASSIVATED
 - PEEK BRAID - PEEK VICTREX GRADE TDS-450CA30 CARBON LOADED - SUPPLIED BY LIGO
- CABLE** 25 COND. 28 AWG. (40 STRD 44 AWG) WITH 2 LAYERS OF KAPTON TAPE
12 TWISTED PAIRS (4 TO 5 TWISTS PER INCH) + 1 WIRE
OVERALL 40AWG COPPER BRAID 50% COVERAGE - SUPPLIED BY LIGO
OVERALL PEEK BRAID MIN. 50% COVERAGE
OVERALL CABLE O.D. WILL BE 0.240 IN.
- CONNECTORS WILL BE SUPPLIED WITH HARDWARE (LENGTH OF SCREWS AS SHOWN ARE APPROXIMATE SCREWS SHOULD BE THE PROPER LENGTH FOR PROPER MATING)**

REV.	DATE	DCN #	DRAWING TREE #
v1	04 MAY 2011	E1100335	
v2	25 MAY 2011	E1100335	
v3	27 MAY 2011	E1100335	

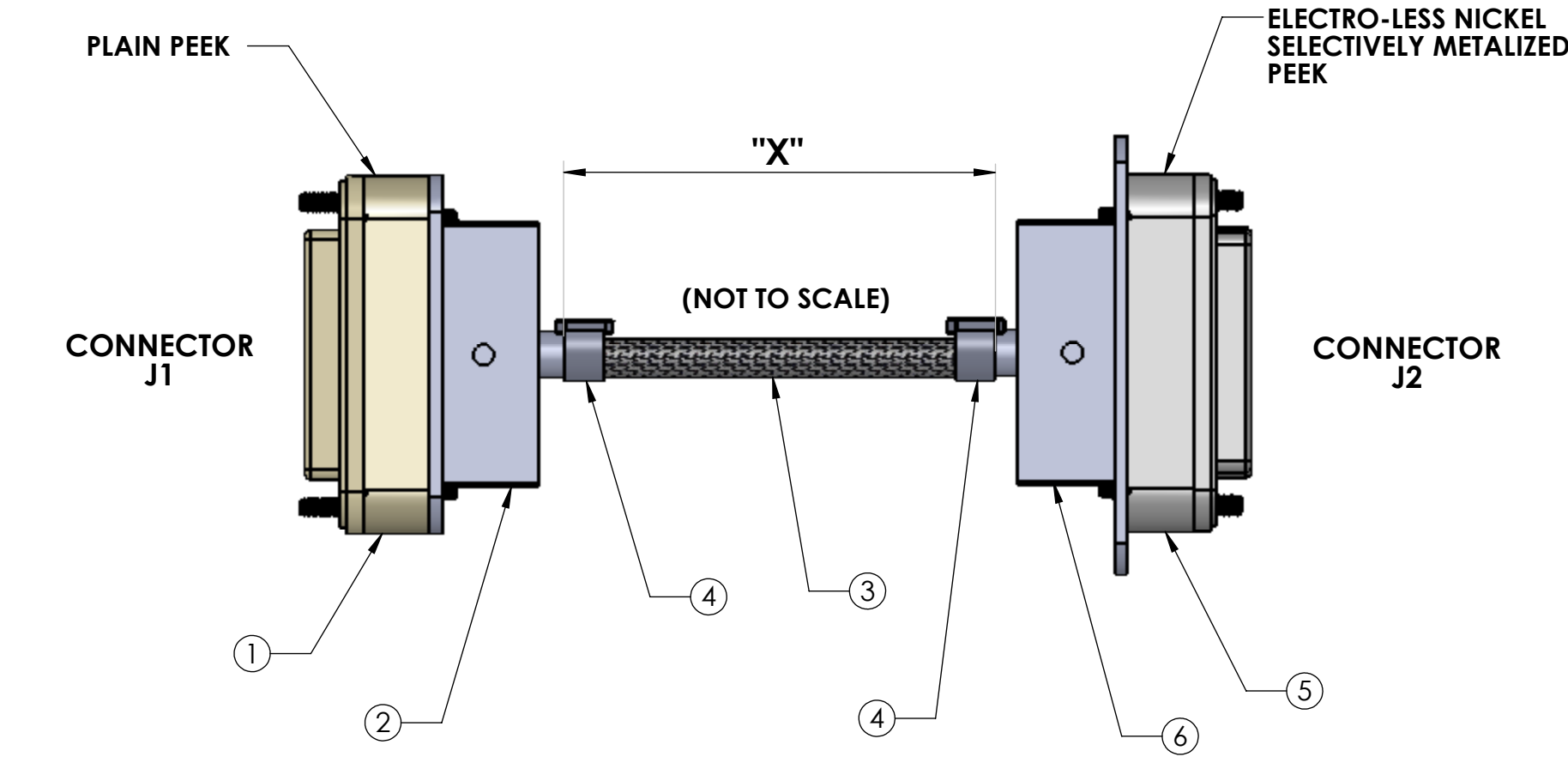
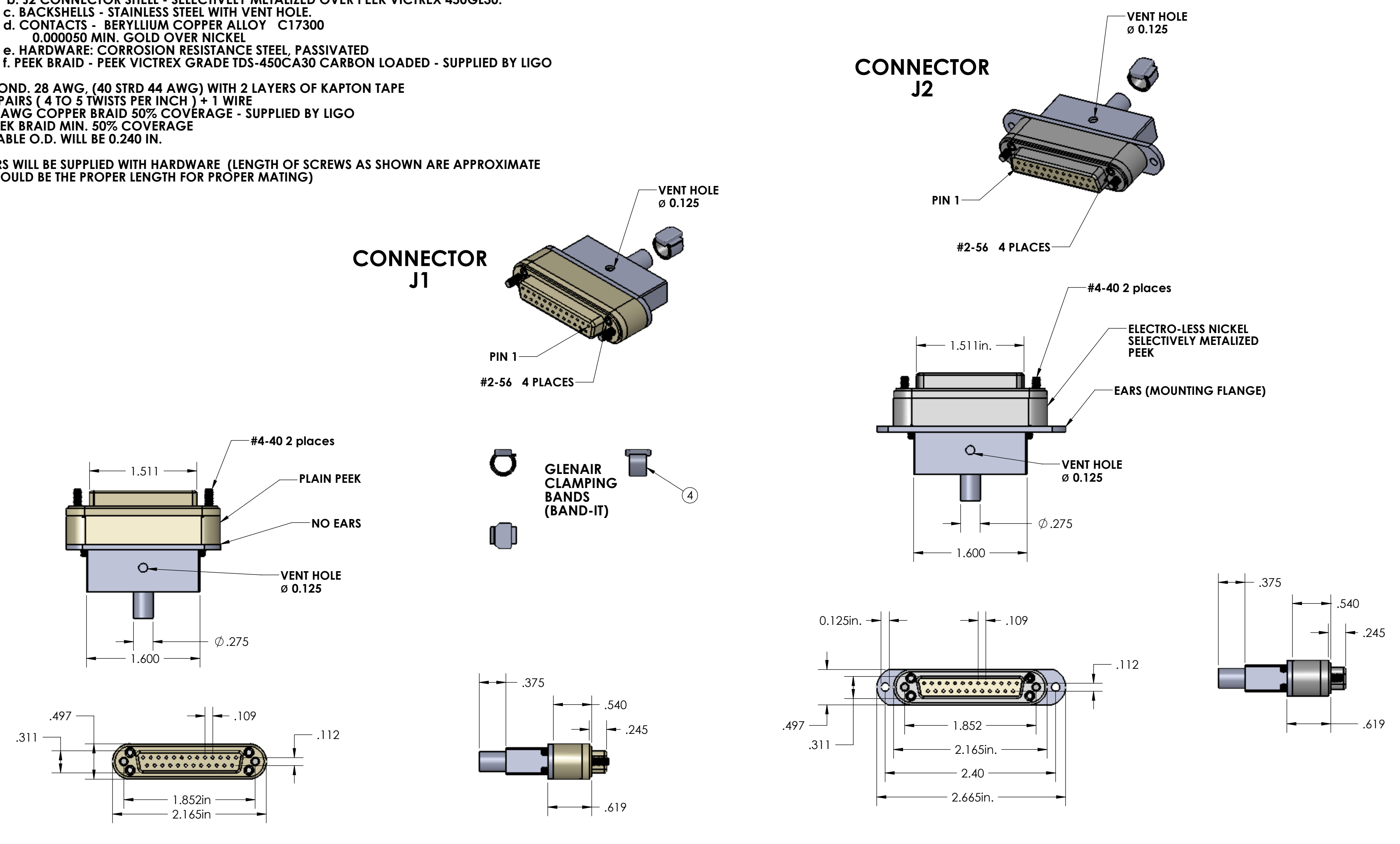

V25A-110 CABLE ASSEMBLY CIRCUIT SUMMARY
V-DB25 F/S1-110-DB25 F/S1

CABLE NAME	COND.- WIRE ID	TWISTED PAIR	LENGTH *	FROM	TO
V25A-110	25 COND. CABLE	(12 TOTAL)	110 in.	Conn. J1	Conn. J2
	W1	SHIELD	110 in	PIN 1, SHELL	PIN 1, SHELL
	W2	TP-1	110 in	PIN 2	PIN 2
	W14		110 in	PIN 14	PIN 14
	W3	TP-2	110 in	PIN 3	PIN 3
	W15		110 in	PIN 15	PIN 15
	W4	TP-3	110 in	PIN 4	PIN 4
	W16		110 in	PIN 16	PIN 16
	W5	TP-4	100 in	PIN 5	PIN 5
	W17		110 in	PIN 17	PIN 17
	W6	TP-5	110 in	PIN 6	PIN 6
	W18		110 in	PIN 18	PIN 18
	W7	TP-6	110 in	PIN 7	PIN 7
	W19		110 in	PIN 19	PIN 19
	W8	TP-7	110 in	PIN 8	PIN 8
	W20		100 in	PIN 20	PIN 20
	W9	TP-8	110 in	PIN 9	PIN 9
	W21		110 in	PIN 21	PIN 21
	W10	TP-9	110 in	PIN 10	PIN 10
	W22		110 in	PIN 22	PIN 22
	W11	TP-10	110 in	PIN 11	PIN 11
	W23		110 in	PIN 23	PIN 23
	W12	TP-11	110 in	PIN 12	PIN 12
	W24		110 in	PIN 24	PIN 24
	W13	TP-12	110 in	PIN 13	PIN 13
	W25		110 in	PIN 25	PIN 25

* The length shown in this list is the length of the cable between the two connectors. Add additional length as necessary for the internal wiring of the connectors and strip length.

ITEM NO.	PART NUMBER	DESCRIPTION	QTY.	LENGTH
1	CUSTOM DB25 FEMALE	DB25 FEMALE CONNECTOR (J1) FOR UHV (PEEK)	1	
2	CUSTOM BACKSHELL	DB25 CONNECTOR BACKSHELL (NO EARS) FOR UHV (STAINLESS)	1	
3	CZ1105 (28 AWG) OR CZ1104 (29 AWG)	25 COND. (12 TW PAIR + 1 WIRE + SHIELD) CABLE WITH COPPER BRAID (SHIELD) AND PEEK OVERBRAID	1	(SEE TABLE)
4	GLENAIR 600-052	GLENAIR 600-052 STANDARD BRAID CLAMP (BAND - IT)	2	
5	CUSTOM DB25 FEMALE	DB25 FEMALE CONNECTOR (J2) FOR UHV (METALIZED PEEK)	1	
6	CUSTOM BACKSHELL	DB25 CONNECTOR BACKSHELL (WITH EARS) FOR UHV (STAINLESS)	1	

PART NO.	LENGTH "X"	CHAMBER	QTY REQ'D.
D1003117-1	175"	BSC10_H1	2
		BSC7_H2	2
		BSC1_L1	1
		BSC5_L1	1
D1003117-2	241"	BSC8_H2	2
		BSC9_H1	2
		BSC3_L1	1
		BSC4_L1	1

V-DB25 F/S1-110-DB25 F/S1		
STANDARD USE FOR THIS CABLE		
SUBSYSTEM	AIR/VAC	STANDARD USE
SEI	IN-VAC	FROM FLANGE TO TRILLIUM PODS

* NOTE: USE WHATEVER LENGTH IS NECESSARY FOR THE INTERNAL WIRING OF THE CONNECTORS AND STRIP LENGTH TO ACHIEVE THE CORRECT OVERALL LENGTHS.

NOTES AND TOLERANCES: (UNLESS OTHERWISE SPECIFIED)

DIMENSIONS ARE IN
TOLERANCES:
.XX ±
.XXX ±
ANGULAR ± °

MATERIAL: Material <not specified>
FINISH: μinch

CALIFORNIA INSTITUTE OF TECHNOLOGY
MASSACHUSETTS INSTITUTE OF TECHNOLOGY

PART NAME: SLC PHOTODETECTOR CABLE UPPER ASSY

DESIGNER: [blank]
DRAFTER: MRUIZ
CHECKER: [blank]
APPROVAL: [blank]

SIZE: D
DWG. NO.: D1003117
REV.: v3

SCALE: 1:1
PROJECTION: [blank]

SHEET 1 OF 1