

BCHG7CBHBI 98.
 G7 F 492 98; F5J 915 J 46F5HC FMHC @A 5M691 G98LZ
 6G9F A 5F? CFA 97 <5B 7 5 @MQ6A DIBC B?GCF
 8M9G:8F5K B; D5FHBI A 69FZ9J GC B 15B8
 J5F 5BHCF HM9? 5DD@7 56@C B BCH98 Q F: 57 9
 C: D5FH: C @C K 98 C B H 9 B 9 L H @ B 9 K H: 5 H F 9 9
 8 5 H G 9 F 5 @ B I A 6 9 F 5 @ B I A 6 9 F G 5 F H 5 H S %
 : C F H 9 : # G H 5 F H 7 @ 9 5 B 8 D F C 7 9 9 8 7 C B G 7 1 H 9 M
 I G 9 A B A I A S % < < < 7 < 5 F 5 7 H F Q 2 I B @ G H 9 G A 9
 C: H 9 D 5 F H 8 7 H 5 H 9 G A 5 @ 9 F 7 < 5 F 5 7 H F G
 9 L 5 A D @ 8 L L L L L L L I J M H M D 9 L L Z G B L L L

U J 7 H L () \$; "J F; B D99? F9GB "BC C H 9 F 5 8 8 H J 9 G
 + " " 5 D D F C L A 5 H 9 K 9 < H 1 " S) \$ @ G
 " " A 5 7 < B 9 5 @ Q F: 5 7 9 G H C F 9 A C J 9 C L @ 9 G 5 B 8 A @ @ B < G < 2
 " " I G 9 C: 5 6 F 5 G J 9 F 9 A C J 5 @ H 7 < B E I 9 G 6 B C H 5 @ C K 9 8 "
 " " 5 @ D 5 F H G < 5 @ 6 9 A 5 B I: 5 7 H F 9 8 B 5 7 7 C F 8 5 B 7 9
 " " K H: C @ D 9 7 < 7 5 H C B 9 S - S S " ("
 % S " 5 @ < 9 @ 7 C @ < C @ G H C 6 9 D F 9 0 5 F 9 8 5 7 7 C F 8 B; H C 9 A < 5 F H
 < 9 @ 7 C @ D F C 8 I 7 H 7 5 H @; Z < 7 & S S S Z F 9 J ("
 % @ 5 @ < 9 @ 7 C @ B G 9 F H G H C 6 9 B G 5 @ 9 8 6 M @; C D 9 F G C B B 9 @
 " " 5: H F 8 9 @ J 9 F M C : : B < G < 9 8 D 5 F H Z I G 9 B H C B 7 " * S
 " " H F 9 5 8 9 8 B G 9 F H G
 % " 5 @ A 5 H F 5 @ G H C 6 9 J F; B A 5 H F 5 @ H Y " B C H K 9 8 B
 F 9 0 5 F G C F D @ : G I B @ G 5 D D F C J 9 8 B 5 8 J 5 B 7 9 B
 " " K F H B; 6 M @; C 2 F 9 9 F H C @; C I 9 S - S S " ("
 % " B C F 9 0 5 F G G < 5 @ 6 9 A 5 8 9 1 B @ G G 5 D D F C J 9 8 B 5 8 J 5 B 7 9 2 5 B 8 B K F H B; Z
 " " 6 M @; C @ 6 C F 5 H C F M B; 9 8 9 F 5 @ K 9 8 F 9 0 5 F G 5 B 8 D F 9 C G; H B G 9 F H F 9 0 5 F G
 " " 5 F 9 B 9 J 9 F 5 7 9 D H 5 6 @ H K 9 A 5 H F 5 @ G C I @ 8 6 9 A 5 8 9 K H: J F; B A 5 H F 5 @
 " " G D 9 7 5 @ 7 F 7 I A G 5 B 7 9 G 7 5 B 6 9 F 9 9 K 9 8 < # K < 9 B 6 F C I: < H H C H 9
 " " 5 H 9 B H C B C: @ C 7 C B H F 5 7 H B; C: : 7 9 F @ F 9 D F 9 0 9 B H H 9 9 I 7 C H F E H F C I; <
 " " 5 A 5 H F 5 @ F 9 J 9 K 6 C 5 F 8 T A F 6 E D F C 7 9 G G F 9 9 F H C @; C I 9 S - S S " ("

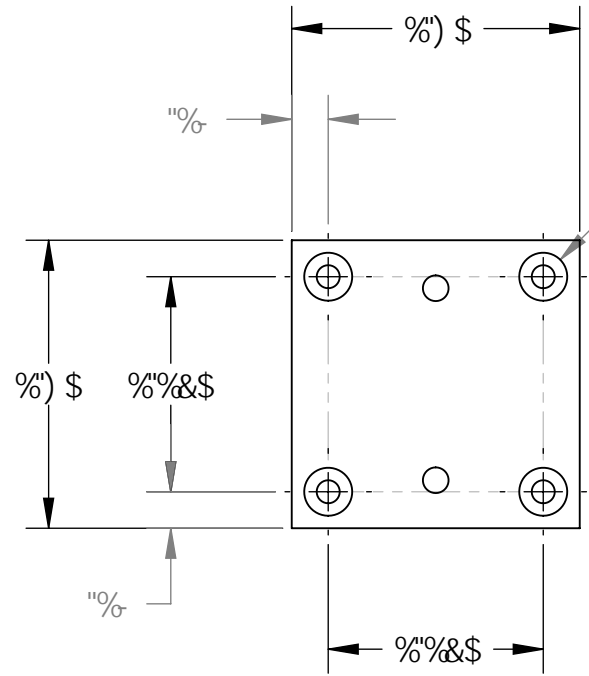

(L · Ø "%&\$ 'HkFI
 □ Ø "'&) · ∇ "'%&

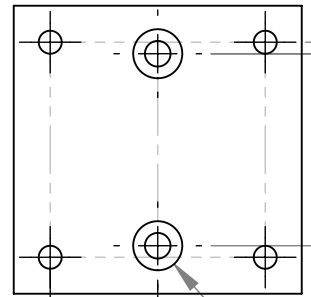

" \$ *
 % " \$ \$ \$ \$

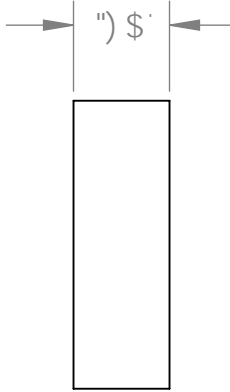

& L · Ø "% ('HkFI
 □ Ø "'&) * · ∇ "'%&

F9J "	85H9	87B:	8F5K B; HF99,
j % & \$ B C J & \$ % \$!	!	!
j & & ' A 5 F & \$ % %	!	!	!
!	!	!	!

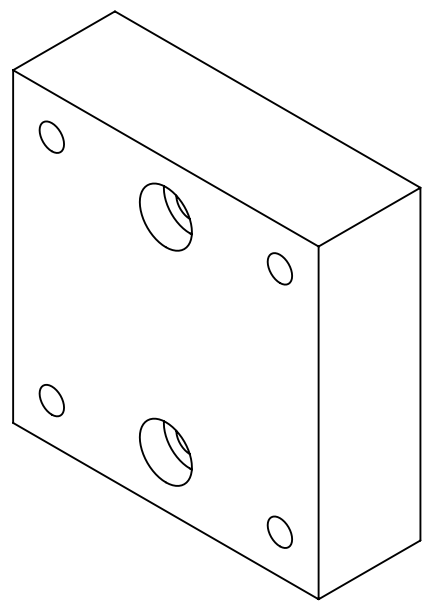

€C J 9K

BCHG5B8HC @F5B79G FI B @GGCH 9FK 49G D97 = 98L				LIGO 75 @ CFB 5 B G H H 9 C: H 7 < BC @; M D5FH85A 9 A 5 G G 5 7 < I G H G B G H H 9 C: H 7 < BC @; M		D99? GD5 7 9F		
8A 9BGC BG5F9 B B7 < 9G		% B H F D F 9 H 8 F 5 K B: D 9 F 5 G A 9 M () 1 % - (" & " F 9 A C J 9 5 @ G: 5 F D 9 8: 9 Q F " S & A B " " " B C B C H G 7 5 @; F C A 8 F 5 K B: " (" 5 @ A 5 7 < B B: : @ B G A I G H 6 9: I @ M G B H K 9 H 7 2: I @ M K 5 H F G C @ 6 @ 5 B 8: F 9 9 C: Q @ I F 2 G @ 7 C B 9 2 5 B 8 7 < @ C F B 9 "		G @ G M B 9 A		89G: B 9 F B " ? @ D 5 H F 7 ? & \$ B C J & \$ % \$ G M 9 B K; " " B C "		F9J "
HC @ F 5 B 7 9 G TL ± % TLL ± % \$		A 5 H F 5 @		58J 5 B 7 9 8 @ C		8F5: H F B " ? @ D 5 H F 7 ? & \$ B C J & \$ % \$		j &
5B: I @ F ± % *		D99? *		B 9 L H 5 G G M		7 < 9 7 9 F		
						5DDFCJ 5 @		
						G 7 5 @ % % DFC > 9 7 H C B.		G < 9 9 H % C: %