

8

7

6

5

4

3

2

1

NOTES: UNLESS OTHERWISE SPECIFIED

- 1. INTERPRET DRAWING PER ASME Y14.5-1994.
- 2. REMOVE ALL SHARP EDGES 0.005" TO 0.015".
- 3. DO NOT SCALE FROM DRAWING.
- 4. ALL MACHINING FLUIDS MUST BE FULLY SYNTHETIC, FULLY WATER SOLUBLE AND FREE OF SULFUR, SILICONE, AND CHLORINE. REFER TO LIGO E0900237 FOR LIST OF APPROVED COOLANTS.
- 5. SCRIBE, ENGRAVE OR MECHANICALLY STAMP (NO DYES OR INKS) A UNIQUE THREE DIGIT SERIAL NUMBER & REVISION NUMBER ON EACH PART. SERIAL NUMBERS START 001 FOR THE FIRST ARTICLE AND PROCEED CONSECUTIVELY .020 DEEP WITH MINIMUM .156 HIGH CHARACTER. BAG AND TAG PARTS WITH THEIR DRAWING PART NUMBER, REVISION, VARIANT OR "TYPE" (IF APPLICABLE), AND QUANTITY. IF PARTS ARE TOO SMALL TO SCRIBE, BAGGING AND TAGGING ALONE IS SUFFICIENT
EXAMPLE: DXXXXXX-VY, TYPE-XX, S/N XXX
- 6. APPROXIMATE WEIGHT =0.894 LB.
- 7. MACHINE ALL SURFACES TO REMOVE OXIDES AND MILL FINISH. USE OF ABRASIVE REMOVAL TECHNIQUES IS NOT ALLOWED. REFER TO LIGO-E0900364.
- 8. PART SHALL BE MANUFACTURED IN ACCORDANCE WITH LIGO SPECIFICATION E0900364.
- 9. ALL MATERIAL IS TO BE VIRGIN MATERIAL (i.e. NO WELD REPAIRS, PLUGS OR RECYCLED MATERIAL). NO REPAIRS SHALL BE MADE UNLESS APPROVED IN ADVANCE, AND IN WRITING, BY LIGO LABORATORY. REFER TO LIGO-E0900364.
- 10. PART WILL BE COMPLETELY PORCELAIN COATED PER LIGO SPECIFICATION E1000083 AFTER FABRICATION, EXCEPT WHERE NOTED.

REV.	DATE	DCN #	DRAWING TREE #
v1	06 MAR 2011	E1000285	-
v2	07 APR 2011	E1100216	-
v3	25 JUN 2011	E1100335	-

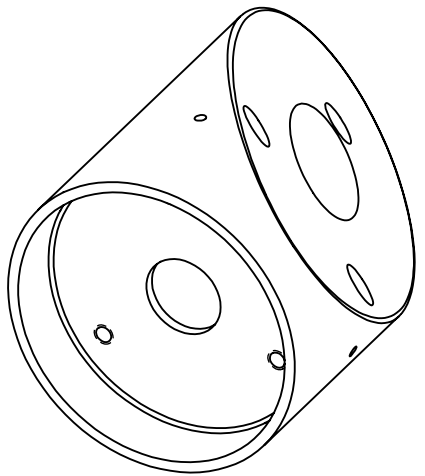
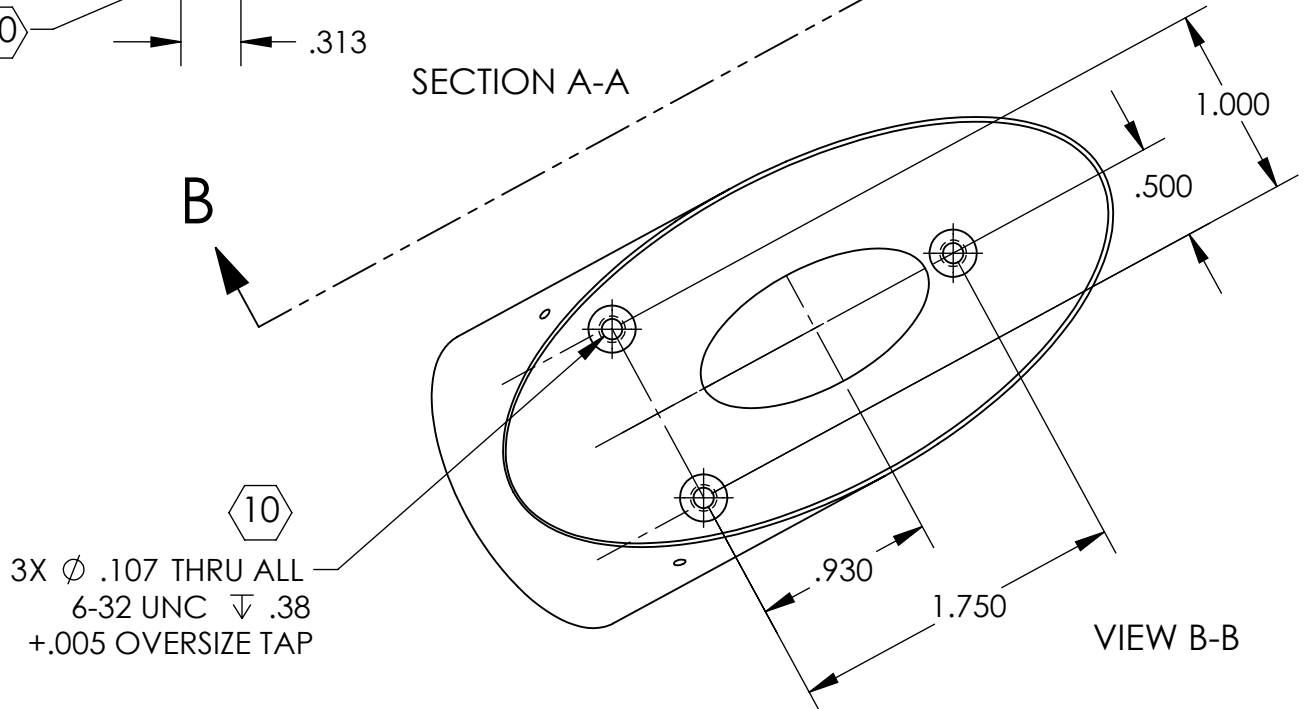
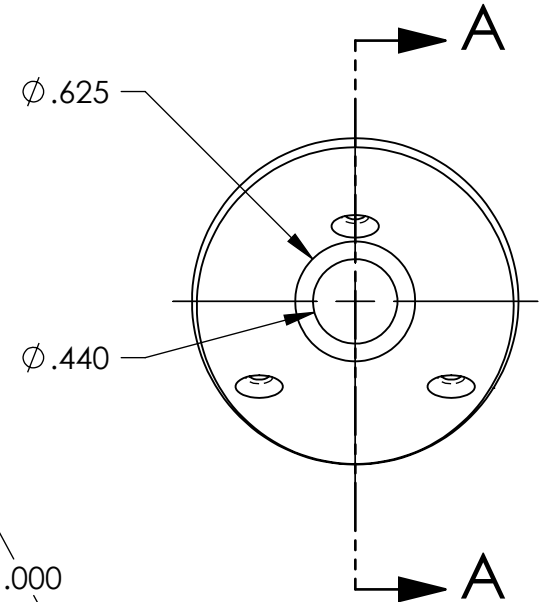
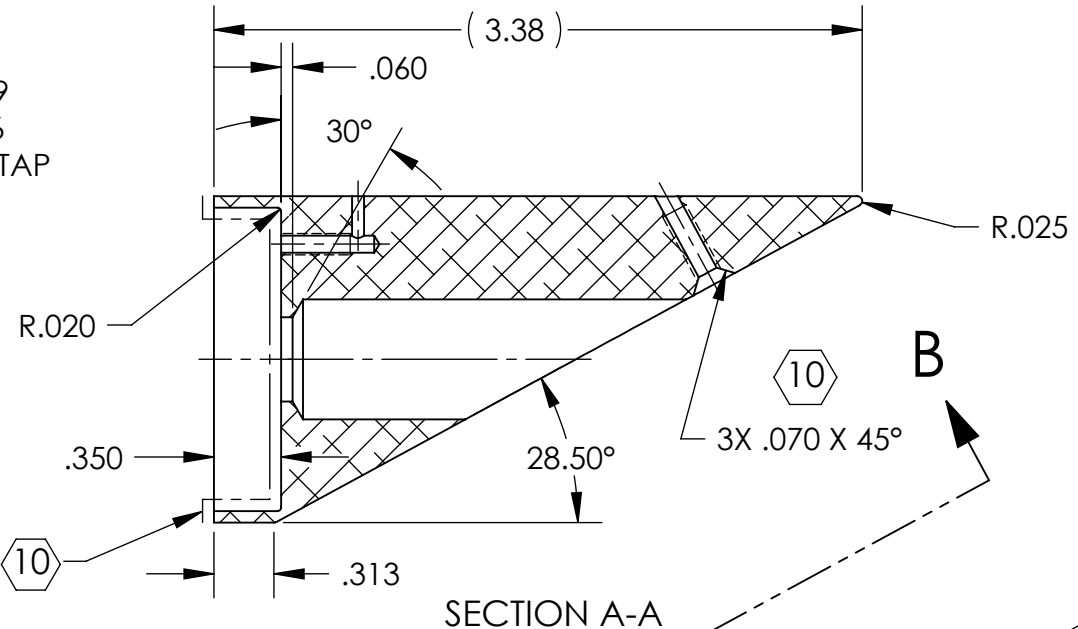
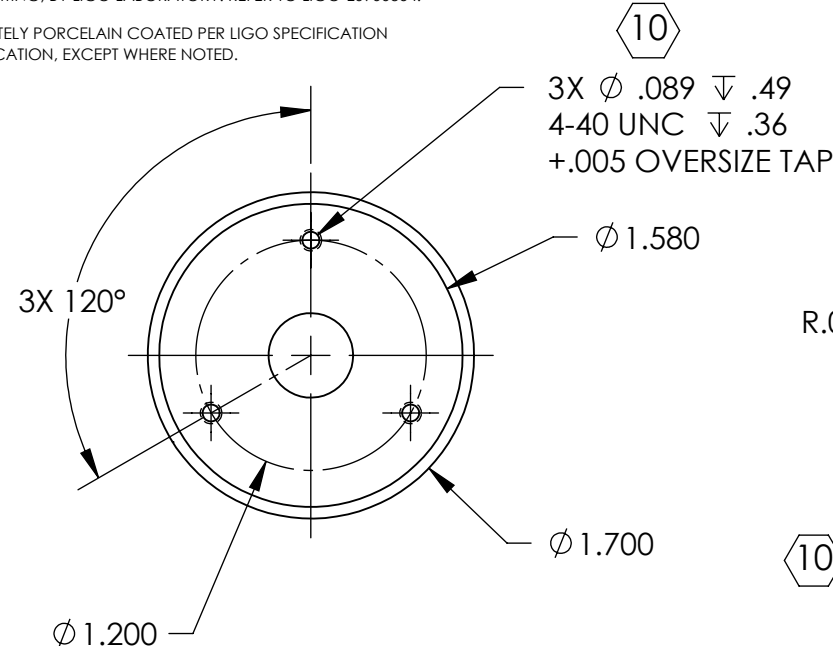
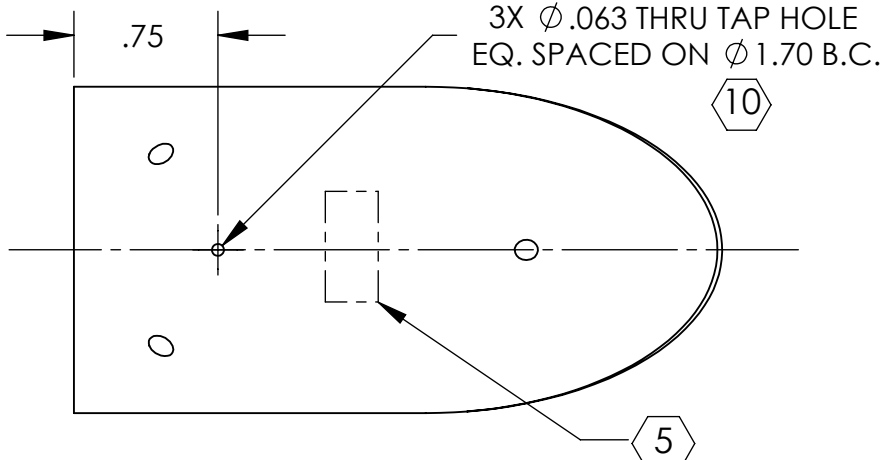

GENERAL VIEW FOR REFERENCE ONLY NO SCALE

NOTES AND TOLERANCES: (UNLESS OTHERWISE SPECIFIED)

DIMENSIONS ARE IN INCHES

TOLERANCES:
 .XX ± .01
 .XXX ± .005
 ANGULAR ± 0.5°

MATERIAL	304 SSSL	FINISH	NOTE 10
----------	----------	--------	---------

LIGO CALIFORNIA INSTITUTE OF TECHNOLOGY MASSACHUSETTS INSTITUTE OF TECHNOLOGY		PART NAME	
SYSTEM	ADVANCED LIGO	SUB-SYSTEM	AOS
NEXT ASSY	D1003013		

DESIGNER			N. Nguyen			17 Nov 2010			SIZE DWG. NO.			REV.					
DRAFTER			N. Nguyen			20 Nov 2010			B			D1003025			v3		
CHECKER			M. Smith			01 Dec 2010			SCALE: 1:1			PROJECTION:			SHEET 1 OF 1		

D1003025_AdlIGO_AOS_SLC Photodetector Housing, PART PDM REV: X-024, DRAWING PDM REV: X-029

8

7

6

5

4

3

2

1