



PROCESS SYSTEMS INTERNATIONAL, INC.

FEDERAL EXPRESS

TO: CALTECH (LIGO)
391 S. HOLLISTON AVE.
LIGO PROJECT MS 51-33
PASADENA, CA 91125

DATE: 01/08/96
TRANS. NO.: CT013
PROJECT NO.: V59049

ATTN: LINDA TURNER

SENT BY: RICH BAGLEY

THE FOLLOWING [] DRAWINGS
[] DOCUMENTS
[X] SPECIFICATIONS

[X] ARE ATTACHED
[] SENT SEPARATELY

Document No.	Rev.	Title	Dwg. Size	Sheets
① V049-2-001	2	ROUGHING PUMP CARTS	A	9
② V049-2-002	3	MAIN TURBOMOLECULAR CARTS	A	8
③ V049-2-003	2	AUXILIARY TURBOMOLECULAR CARTS	A	7
④ V049-2-033	2	GENERAL EQUIPMENT REQUIREMENTS	A	14

- ① LIG0-ES60004-02-V
- ② LIG0-ES60005-03-V
- ③ LIG0-ES60006-02-V
- ④ LIG0-ES60007-02-V

CC:

ISSUED FOR: [] APPROVAL [] PRELIMINARY
[] REVIEW [] CONSTRUCTION
[X] INFORMATION [] DISTRIBUTION

ENCL: [5] PRINTS [] REPRODUCIBLES

PAGE 1 OF 1

**SPECIFICATION FOR
MAIN TURBOMOLECULAR CARTS
FOR
LIGO VACUUM EQUIPMENT**

Hanford, Washington
and
Livingston, Louisiana

PREPARED BY: David Moore
 QUALITY ASSURANCE: Alan Hubbard
 TECHNICAL DIRECTOR: D. C. Williams
 PROJECT MANAGER: Robert Bayley

JAN 08 1996

Information contained in this specification and its attachments is proprietary in nature and shall be kept confidential. It shall be used only as required to respond to the specification requirements, and shall not be disclosed to any other party.

REV LTR.	BY-DATE	APPD. DATE	DESCRIPTION OF CHANGE
3	Sm 12/26/95	D. Williams 12-29-95	REVISED FOR PURCHASE DED0034
2	Sm 11/9/95		REVISED PER CLIENT COMMENTS DED0015
1	Sm 11/2/95		REVISED ATTACHMENT C P&ID V049-0-041 TO P2
02	Sm 10/16/95	D. Williams 10-20-95	REVISED & ISSUED FOR QUOTATION & APPROVAL DED0004
P1	Tm 59-26-95		REVISED FOR UPDATED PRELIMINARY DESIGN

PROCESS SYSTEMS INTERNATIONAL, INC.				SPECIFICATION		
INITIAL APPROVALS	PREPARED	DATE	APPROVED	DATE	Number	Rev.
	Sm	6/14/95	RES	9/26/95	V049-2-002 A LIGO-E960005-03-V	3

TABLE OF CONTENTS

- 1.0 Scope
- 2.0 Schedule
- 3.0 Equipment Requirements
- 4.0 Design Requirements
- 5.0 Required Documentation
- 6.0 Shop Testing
- 7.0 Inspection
- 8.0 Warranty

Attachment A	Quality Assurance Requirement Summary
Attachment B	V049-2-033 Rev. 1 General Equipment Requirements
Attachment C	V049-4-011 Rev. P3 Pump Cart Arrangement

SPECIFICATION

Number	V049-2-002	Rev.
A		3

1.0 SCOPE

This specification covers the minimum requirements for the design, materials, fabrication, assembly, inspection, testing, preparation for shipping, and shipment of the main turbomolecular pump carts (and backing pump carts).

All attachments are part of this specification.

The specified equipment is intended for use as part of the Vacuum Equipment supplied for the Laser Interferometer Gravitational-Wave Observatory (LIGO). LIGO, which is operated by Caltech and MIT under an NSF contract, includes two installations at widely separated sites: near Hanford, WA and Livingston, LA. Each installation contains laser interferometers in an L shape with 4 km arms, a vacuum system for the sensitive interferometer components and optical beams, and other support facilities.

Information contained in this specification and its attachments is proprietary in nature and shall be kept confidential. It shall be used only as required to respond to the specification requirements, and shall not be disclosed to any other party.

2.0 SCHEDULE

2.1 Equipment delivery (for pairs of carts) shall be as follows:

	<u>Quantity</u>	<u>Date</u>
PSI (Westboro, MA)	2	4/1/96
Washington Site	4	8/1/96
Louisiana Site	4	8/10/97
Total Required	10	

2.3 Acceptances at the sites (the start of Vendor's warranty periods) are expected to occur on a staggered basis, within 6 months of delivery.

SPECIFICATION

Number

A

V049-2-002

Rev.

3Page 3 of 8

Number

Rev.

3.0 EQUIPMENT REQUIREMENTS

The main turbomolecular pump carts are to be used to pump down large volumes from 1 torr to 1×10^{-6} torr. The minimum speed at the inlet port shall be 1,400 l/s for nitrogen at 1×10^{-3} torr. The pump set shall be capable of a throughput of at least 5 torr-liters per second at a backing pressure of 1 torr. The pump set shall be capable of pumping a volume of at least 2,000 cubic meters (from 1 torr to 1×10^{-6} torr) without overheating.

The backing pump will be used to rough pump volumes up to 70 m^3 from atmosphere. The cart shall be equipped with a bypass line and manual valving to allow the turbo pump to be bypassed during early stages of pumpdown.

- 3.1 Vendor to specify system performance (speed vs. pressure curve) when the cart is separated (see paragraph 4.1.1).

4.0 DESIGN REQUIREMENTS

The main turbo pump carts will be required to operate under two distinct operating conditions: Beam Tube Evacuation and Vacuum Equipment Evacuation.

1. Beam Tube Pumping

The main turbomolecular pumps will be used initially to evacuate the 2000 m^3 Beam Tube. For this case all of the vacuum pump components will be mounted on a single cart (or two frames bolted together). It is the intent of this specification to allow this cart configuration to be the suppliers standard design.

The Beam Tube evacuation will occur prior to completion of the Vacuum Equipment Building. During this phase, a temporary structure will house the pumping cart. The pumping cart will be located on the Beam Tube Anchor Foundation (see Attachment D).

2. Vacuum Equipment Pumping

For evacuating the Vacuum Equipment during installation and maintenance, the pumping carts will be separated into two sections (by the buyer). The turbo molecular pump will be close coupled to the Vacuum Equipment in the Vacuum Equipment Room. It will discharge into a vacuum header connected to dry backing pump which will be located in a separate Mechanical Equipment Room (to minimize noise and vibration).

The turbomolecular cart will be modified by PSI to reduce vibration transmission into the vacuum vessels and into the floor.

Number

Rev.

SPECIFICATION

Number

A

V049-2-002

Rev.

3

4.1 Mechanical Requirements

- 4.1.1 Each turbomolecular pump set shall consist of a "wide range" magnetically levitated turbomolecular pump backed by an oil-free pump (diaphragm, piston or scroll pump) on separate carts. Also included on the carts are the accessories described below and on the attached P&ID. Initial operation will require the turbo cart to be mounted on top of the backing cart. Future operation will have the turbopump and backing pumps separated via the following vacuum header: 240' of 4" diameter pipe, (6) 90 degree elbows, (1) 45 degree elbow, (1) tee (branch), 10' of 1 1/2" flex hose between turbopump discharge and header.
- 4.1.2 Each cart shall be a complete system mounted on a frame suitable for operation in a Federal Standard 209 Class 50,000 environment (cleanroom). Vibration isolation supports shall be included.
- 4.1.3 The design of the carts shall preclude contamination of the vacuum chambers during the life of the equipment, even in the event of equipment failure or operator error.
- 4.1.4 The inlet connection to the turbomolecular pump will be a 12" O.D. conflat. Turbomolecular pumps shall be supplied with protective inlet screens.
- 4.1.5 The process outlet from the turbo pump cart shall incorporate a 10' long flex line for connection to a vacuum header. This connection shall, depending on the required tube size, be an ISO Quick Flange or Large Flange with double claw clamps. Seals shall be non-lubricated baked Viton O-rings.
- 4.1.6 Provision for sealed connection from the backing pump outlet to a ducted facility exhaust system shall be provided.
- 4.1.7 There shall be no oil in the pumping path.
- 4.1.8 Any required utility connections (such as for cooling water) shall be manifolded to a single connection point and terminated appropriately (such as with an isolation valve and a 1/2" quick disconnect fitting). Filtered cooling water will be provided as follows:

Supply Temperature:	20 - 25C
Supply Pressure:	3. - 5. bara
Return Temperature:	25 - 30C
Return Pressure:	2. - 4. bara

SPECIFICATION

Number	V049-2-002	Rev.
A		3

4.2.2 Controls Requirements

4.2.2.1 Controls for local operation shall be provided. The buyer will interconnect the cart wiring when they are installed in the split location for vacuum equipment pumping (terminals to be provided by the vendor). In addition, provide terminal strips in a junction box to interface with the future LIGO control system. The following signals shall be provided:

<u>Description</u>	<u>Signal Type</u>
Pump Running (Each Pump)	Dry Contacts
Auto. Valve Open & Closed	Dry Contacts
Turbo Pump Inlet Vacuum (2)	0 - 10 VDC (2)
Backing Pump Vacuum	0 - 10 VDC
Purge Gas Shutdown	Dry Contacts

4.2.2.2 The pump carts shall be self-contained so that, under power failure or pump failure, interlocks shall prevent pumped chambers from being vented or from being exposed to a non-operating pump.

4.2.2.3 A manual gate valve on the chamber nozzle will be provided by others. A fail closed pneumatically actuated valve (with pilot solenoid and open and close limit switches) shall be provided on the outlet of the roots pump cart. The controls necessary to close this valve on pump failure shall be incorporated into the cart controls. The cart shall contain an air supply volume (tank with charge valve and gage pressure) of sufficient capacity to operate the valve and maintain operation for 48 hours.

4.2.2.4

4.2.2.5 Pumps shall be stopped and started by pushbutton switches located on the turbo cart. The backing cart shall be capable of being started and stopped by a signal from the turbo cart.

4.2.2.6 Vendor must list in his quotation all safety devices (such as flow switches, pressure switches, temperature switches, safety relief valves, etc.) supplied with the systems.

4.2.2.7 Vendor must provide in his quotation a brief description of all operational sequences such as startup, normal operation, normal shutdown, safety shutdowns, etc.

SPECIFICATION		
Number	V049-2-002	Rev.
A		3

4.2.3 Power Requirements

4.2.4 Purge Gas

Clean, dry, air will be supplied at 15 psig for use as seal purge gas for the vacuum pumps requiring this utility.

4.2.3.1 Power connection to the cart shall be by an appropriate 20' long cord with twist-lock, NEMA type plug configuration (a single connection for the cart, including controllers when configured as one assembly and two cards and plugs when separated into two sections). Required controllers and overload protection shall be provided on the cart. Vendor must provide specifications for the power and control cables needed to connect the separated cart components. Field wiring cables will be provided by buyer when the turbopump is remotely located. Vendor will provide the cables needed when the turbopump is located on the cart.

5.0 REQUIRED DOCUMENTATION

Documentation requirements listed in Attachment B and the QA requirements form, Attachment A, shall be provided according to the Buyer's schedule.

6.0 SHOP TESTING

In addition to the Vendor's standard tests, each electrically powered vacuum pump cart shall be tested for speed, acoustic noise, ultimate pressure, leakage and operation of protective features. All safety interlocks shall be tested for proper operation by simulating the faulted condition.

7.0 INSPECTION

All testing and inspections called for in Attachment B (Specification V049-2-033, General Equipment Requirements) shall be performed by the Vendor. Additional quality assurance requirements are listed in Attachment A, Quality Assurance Requirements Summary.

8.0 WARRANTY

Refer to Specification V049-2-034, Equipment Purchase Commercial Requirements for Warranty Requirements.

SPECIFICATION

Number	V049-2-002	Rev.
A		3

Page 8 of 8

Number

Rev.

ATTACHMENT "A"
LIGO QUALITY ASSURANCE REQUIREMENTS SUMMARY

LIGO VACUUM EQUIPMENT	VENDOR:					JOB NO.: V59049
EQUIPMENT: MAIN TURBOMOLECULAR PUMPS	VENDOR ENG. OFFICE:					DWG. NO.:
PSI P.O. NO:	VENDOR FACTORY:					SPECNO: V049-2-002
TESTING INSPECTION AND DOCUMENTATION RECORD	Submittal After P.O.	Witnessed by PSI	Approval by PSI	Copies Req'd for PSI Files	Record in Mfr's File	<u>Remarks:</u> <u>Inspector:</u> <u>Date:</u>
MILESTONE SCHEDULE	2 Wks.		X	2	X	
VENDOR Q.A. PLAN	2		X	2	X	
CLEANING PROCEDURE	2		X	2	X	
PREP FOR SHIPMENT PROCEDURE	6		X	2	X	
ASSEMBLY DRAWINGS	4		X	2	X	
DESIGN REVIEW		X			X	Prior to release for fabrication.
IN-PROCESS INSPECTIONS	TBD	X		2	X	
OPERATION & MAINTENANCE MANUALS	8			5	X	
SHOP TEST PLAN			X	2	X	Prior to release for fabrication.
SHOP TEST (WITH REPORT)		X		2	X	Prior to release for shipment.

**CASE I
BEAM TUBE EVACUATION**

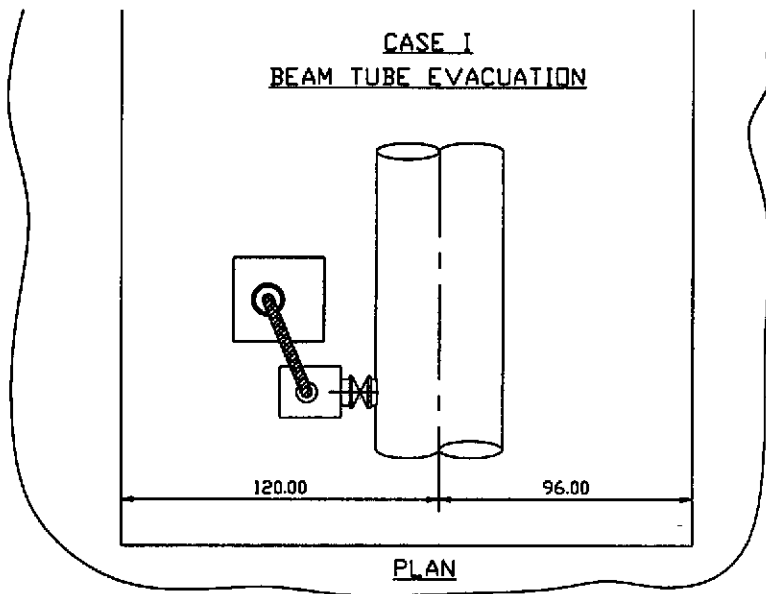

**CASE II
VACUUM EQUIPMENT EVACUATION**

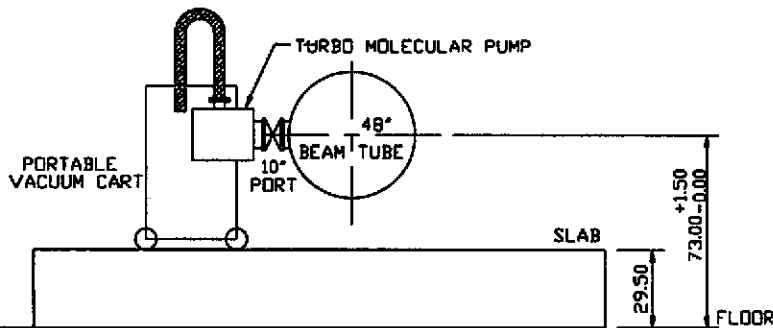
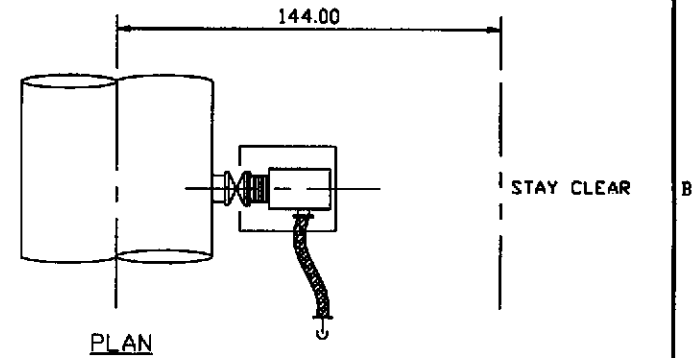

ELEVATION AT BEAM TUBE

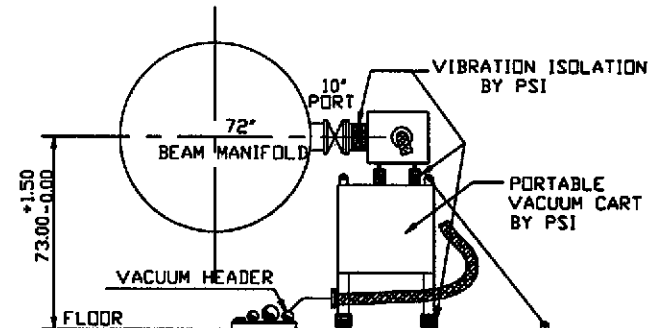

ELEVATION AT BEAM MANIFOLD

PROPRIETARY AND CONFIDENTIAL

THIS DOCUMENT CONTAINS PROPRIETARY INFORMATION BELONGING TO PROCESS SYSTEMS INTERNATIONAL, INC. OR ITS AFFILIATED COMPANIES AND SHALL BE USED ONLY FOR THE PURPOSE FOR WHICH IT WAS SUPPLIED. IT SHALL NOT BE COPIED, REPRODUCED OR OTHERWISE USED, NOR SHALL SUCH INFORMATION BE FURNISHED IN WHOLE OR IN PART TO OTHERS EXCEPT IN ACCORDANCE WITH THE TERMS OF ANY AGREEMENT UNDER WHICH IT WAS SUPPLIED OR WITH THE PRIOR WRITTEN CONSENT OF PROCESS SYSTEMS INTERNATIONAL, INC. AND SHALL BE RETURNED UPON REQUEST.

UNLESS OTHERWISE SPECIFIED DIMENSIONS ARE IN INCHES
TOLERANCES:
FRACTIONAL ±
ANGULAR APPROX 10°-30° BEND ±2°
TWO PLACE DECIMAL ±.010
THREE PLACE DECIMAL ±.005
FINISHED SURFACE DIMS
BREAK CORNERS IN OUT
REMOVE ALL BURRS

DO NOT SCALE THIS DWG.
USED ON
NEXT ASS'Y.

REV	DESCRIPTION	CHKD	DRWN	DATE	DESN
P3	DESIGN UPDATE			12-1-95	RM
P2	DESIGN UPDATE			10-24-95	RM
P1	PRELIMINARY DESIGN UPDATE			9-25-95	

PROCESS SYSTEMS INTERNATIONAL, INC.
20 WALKUP DR. WESTBOROUGH, MASSACHUSETTS 01581 USA

**TURBO PUMP CART ARRANGEMENTS
LIGO VACUUM EQUIPMENT**

CAR FILE V0494011	SIZE B	DWG. NO. V049-4-011	REV. P3
SCALE 1/4"=1'-0"		SHEET 1 OF 1	