

This document provides details about the LLO electronics racks. It may be examined through three separate but interconnected methods: racks may be found searching MAPS of the observatory, or for AREAS in which they reside, or by searching SUBSYSTEMS that they service.

[Search by
MAP](#)

[Search by
AREA](#)

[Search by
SUBSYSTEM](#)

[Search by
DocDB](#)

[<< Start](#)

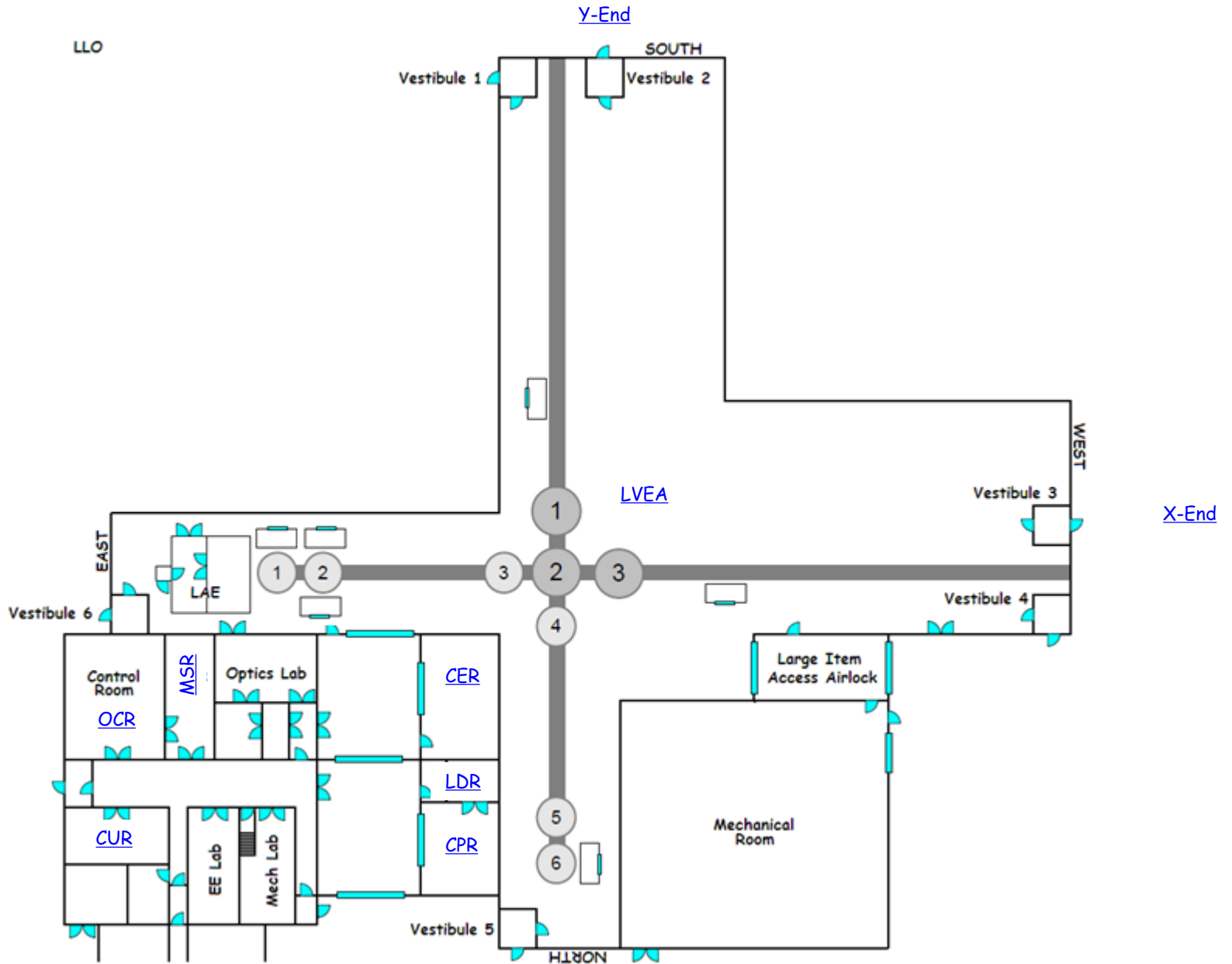

[X-End](#)

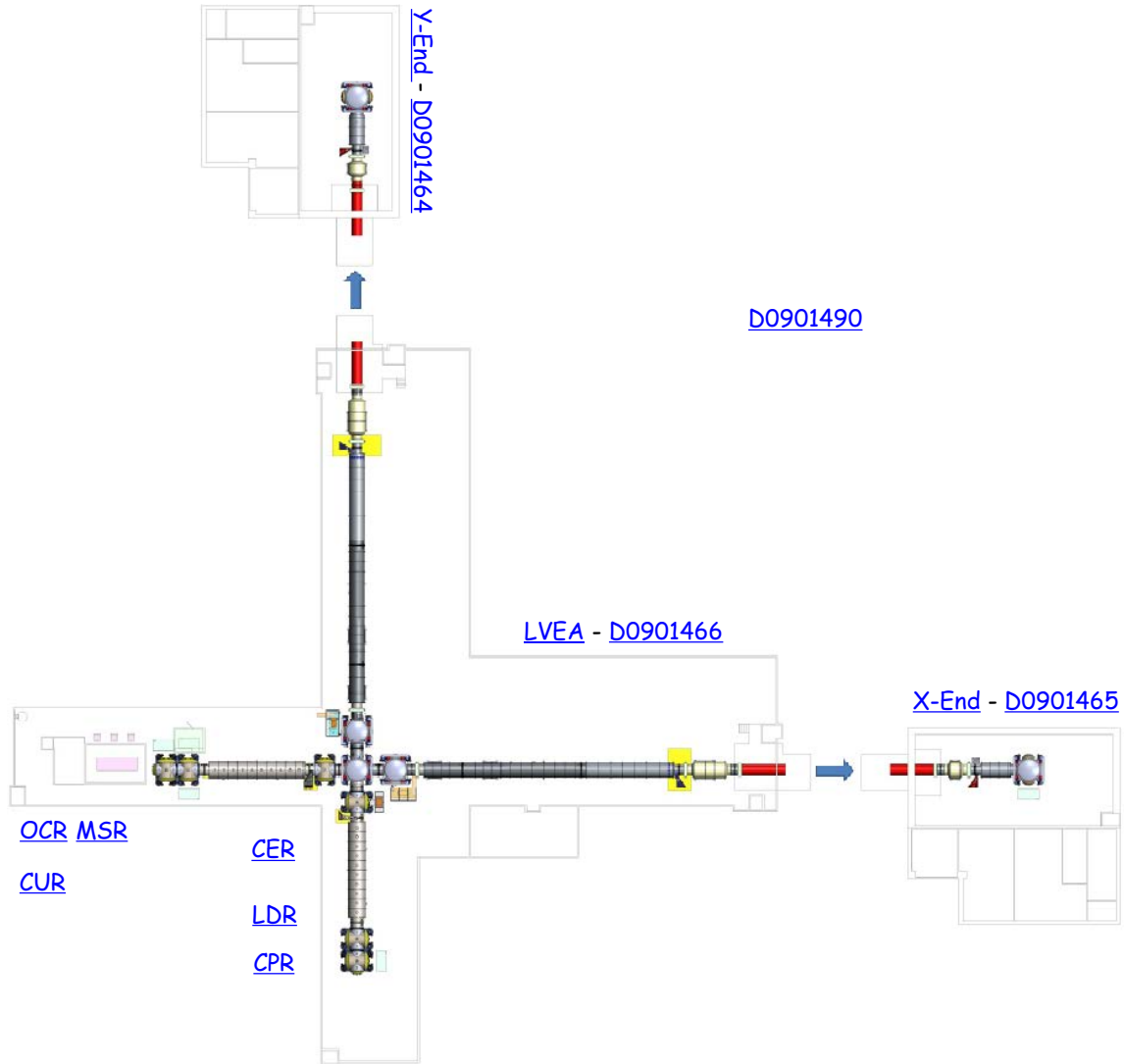

LLO electronics racks are installed in a variety of *LOCATIONS*. Generally speaking, each location houses a specific type of rack. Front-end computers are housed in the [MSR](#). Electronics racks with IO chassis are housed in the [CER](#). Other electronics racks that interface to chambers are located in the [LVEA](#), [X-End](#) and [Y-End](#) areas. Power supplies are housed in the [CPR](#). And finally, test racks for electronics are spread throughout the facility, housed wherever they are required.

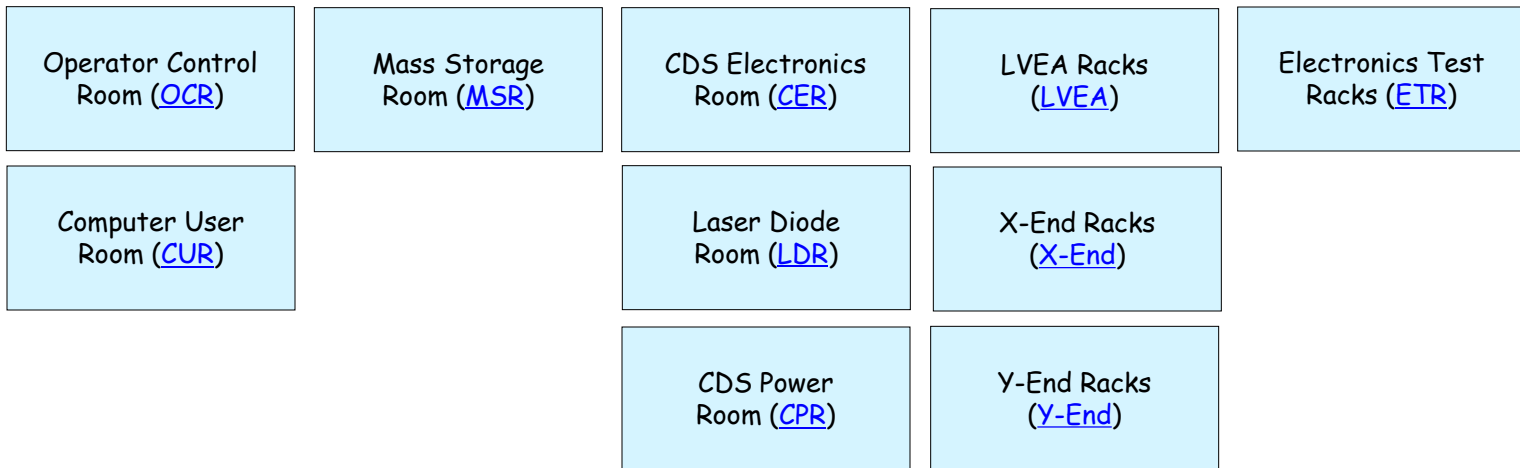

I/O Subsystems are another way to view the racks that are installed in a variety of locations. Generally speaking, each subsystem has racks that are positioned in several physical locations. The subsystems are: AOS, DAQ, ISC, PSL, SEI, SUS, VAC, and VDC. TCS is a part of AOS. PEM and OAF are part of DAQ. HEPI is part of SEI.

| | | |
|---|---|---|
| <p>Auxiliary Optics CER:(AOS / TCS) LVEA:(AOS / TCS) CERX:(AOS / TCS) VEAX:(AOS / TCS) CERY:(AOS / TCS) VEAY:(AOS / TCS)</p> | <p>Pre-stabilized Laser CER:(PSL) LVEA:(PSL) CERX:(PSL) VEAX:(PSL) CERY:(PSL) VEAY:(PSL)</p> | <p>Vacuum CER:(VAC) LVEA:(VAC) CERX:(VAC) VEAX:(VAC) CERY:(VAC) VEAY:(VAC)</p> |
| <p>Interferometer Sensing and Control CER:(ISC) LVEA:(ISC) CERX:(ISC) VEAX:(ISC) CERY:(ISC) VEAY:(ISC)</p> | <p>Seismic Isolation CER:(SEI) LVEA:(SEI) CERX:(SEI) VEAX:(SEI) CERY:(SEI) VEAY:(SEI)</p> | <p>DC Power CER:(VDC) LVEA:(VDC) CERX:(VDC) VEAX:(VDC) CERY:(VDC) VEAY:(VDC)</p> |
| <p>Data Acquisition CER:(DAQ / PEM / OAF) LVEA:(DAQ / PEM / OAF) CERX:(DAQ / PEM / OAF) VEAX:(DAQ / PEM / OAF) CERY:(DAQ / PEM / OAF) VEAY:(DAQ / PEM / OAF)</p> | <p>Suspensions CER:(SUS) LVEA:(SUS) CERX:(SUS) VEAX:(SUS) CERY:(SUS) VEAY:(SUS)</p> | <p>Facilities CER:(FAC) LVEA:(FAC) CERX:(FAC) VEAX:(FAC) CERY:(FAC) VEAY:(FAC)</p> |

LLO Rack Naming Scheme

CDS racks are named according to site, IFO designation, subsystem use, station (location) and sequence. (See [LIGO-G1001030](#))

| Site | Description | IFO | Subsystem | Description | Station | Description | Rack Number |
|------|-------------|-----|-----------|---------------------------------|---------|-------------------------|-------------|
| L | Livingston | 1 | AOS | Auxiliary Optics | C | [Corner] Common | 1 |
| H | Hanford | 2 | DAQ | Data Acquisition | MS | Mass Storage | 2 |
| M | MIT | | ETR | Electronics Test Rack | R | [Corner] Remote (Field) | 3 |
| C | CIT | | FAC | Facilities and Infrastructure | XC | X-End Common | 4 |
| | | | ISC | IFO Sensing and Control | XR | X-End Remote [Field] | 5 |
| | | | LDR | Laser Diode Room | YC | Y-End Common | 6 |
| | | | OAF | Online Adaptive Filtering | YR | Y-End Remote [Field] | 7 |
| | | | PEM | Physical Environment Monitoring | | | 8 |
| | | | PSL | Pre-stabilized Laser | | | 9 |
| | | | SEI | Seismic Isolation | | | 10 |
| | | | SUS | Suspensions | | | 11 |
| | | | TCS | Thermal Compensation System | | | 12 |
| | | | VAC | Vacuum | | | etc. |
| | | | VDC | Voltage - DC | | | |

LLO Rack Names

CDS racks are named according to site, IFO designation, subsystem use, station (location) and sequence. (See [LIGO-G1001030](#))

| Rack | Rack Designator | Subsystem | Location | Comment |
|------|-----------------|-----------|-------------------------------|---------------------------------|
| 1 | L1-TCS-C1 | AOS | Common Electronics Room | |
| 2 | L1-TCS-R1 | AOS | Remote Electronics Rack | |
| 3 | L1-TCS-R2 | AOS | Remote Electronics Rack | |
| 4 | L1-TCS-XC1 | AOS | X End Remote Electronics Rack | |
| 5 | L1-TCS-XR1 | AOS | X End Remote Electronics Rack | |
| 6 | L1-TCS-YC1 | AOS | Y End Common Electronics Rack | |
| 7 | L1-TCS-YR1 | AOS | Y End Remote Electronics Rack | |
| 8 | L1-OAF-C1 | DAQ | Common Electronics Room | |
| 9 | L1-ETR-01 | DAQ | DAQ Electronics Test Rack | DAQ Electronics Test Rack |
| 10 | L1-OAF-XC1 | DAQ/ISC | X End Common Electronics Rack | |
| 11 | L1-OAF-YC1 | DAQ/ISC | Y End Common Electronics Rack | |
| 12 | L1-ISC-C1 | ISC | Common Electronics Room | |
| 13 | L1-ISC-C2 | ISC | Common Electronics Room | |
| 14 | L1-ISC-C3 | ISC | Common Electronics Room | |
| 15 | L1-ISC-C4 | ISC | Common Electronics Room | |
| 16 | L1-ISC-R1 | ISC | Remote Electronics Rack | |
| 17 | L1-ISC-R2 | ISC | Remote Electronics Rack | |
| 18 | L1-ISC-R3 | ISC | Remote Electronics Rack | |
| 19 | L1-ISC-XR1 | ISC | X End Remote Electronics Rack | |
| 20 | L1-ISC-YR1 | ISC | Y End Remote Electronics Rack | |
| 21 | L1-ETR-04 | OPTICS | Optics Electronics Lab Rack | Optics Electronics Lab Rack |
| 22 | L1-LDR-C1 | PSL | Laser Diode Room Rack | |
| 23 | L1-LDR-C2 | PSL | Laser Diode Room Rack | |
| 24 | L1-PSL-C1 | PSL | Common Electronics Room | |
| 25 | L1-PSL-R1 | PSL | Remote Electronics Rack | |
| 26 | L1-PSL-R2 | PSL | Remote Electronics Rack | |
| 27 | L1-SEI-C1 | SEI | Common Electronics Room | SEI HAM 1 and HAM 6 |
| 28 | L1-SEI-C2 | SEI | Common Electronics Room | SEI HAM 2 and HAM 3 |
| 29 | L1-SEI-C3 | SEI | Common Electronics Room | SEI HAM 4 and HAM 5 |
| 30 | L1-SEI-C4 | SEI | Common Electronics Room | SEI BCS1 |
| 31 | L1-SEI-C5 | SEI | Common Electronics Room | SEI BCS2 |
| 32 | L1-SEI-C6 | SEI | Common Electronics Room | SEI BCS3 |
| 33 | L1-SEI-XC1 | SEI | X End Common Electronics Rack | SEI BCS4 |
| 34 | L1-SEI-YC1 | SEI | Y End Common Electronics Rack | SEI BCS5 |
| 35 | L1-ETR-05 | SEI | HAM ISI Electronics Test Rack | HAM ISI Electronics Test Rack |
| 36 | L1-ETR-07 | SEI | Triple Electronics Test Rack | Triple Electronics Test Rack |
| 37 | L1-SUS-C1 | SUS | Common Electronics Room | SUS ITM, FM, and BS (1 of 2) |
| 38 | L1-SUS-C2 | SUS | Common Electronics Room | SUS ITM, FM, and BS (2 of 2) |
| 39 | L1-SUS-C3 | SUS | Common Electronics Room | SUS HAM 2 (1 of 2) |
| 40 | L1-SUS-C4 | SUS | Common Electronics Room | SUS HAM 2 (2 of 2) |
| 41 | L1-SUS-C5 | SUS | Common Electronics Room | SUS ITMX, ITMY, and BS (1 of 2) |
| 42 | L1-SUS-C6 | SUS | Common Electronics Room | SUS ITMX, ITMY, and BS (2 of 2) |

| | | | | |
|----|------------|-----|----------------------------------|----------------------------------|
| 43 | L1-SUS-C7 | SUS | Common Electronics Room | SUS HAM 5 and HAM 6 (1 of 2) |
| 44 | L1-SUS-C8 | SUS | Common Electronics Room | SUS HAM 5 and HAM 6 (2 of 2) |
| 45 | L1-SUS-R1 | SUS | Remote Electronics Rack | |
| 46 | L1-SUS-R2 | SUS | Remote Electronics Rack | |
| 47 | L1-SUS-R3 | SUS | Remote Electronics Rack | |
| 48 | L1-SUS-R4 | SUS | Remote Electronics Rack | |
| 49 | L1-SUS-R5 | SUS | Remote Electronics Rack | |
| 50 | L1-SUS-R6 | SUS | Remote Electronics Rack | |
| 51 | L1-SUS-XC1 | SUS | X End Common Electronics Rack | |
| 52 | L1-SUS-XC2 | SUS | X End Common Electronics Rack | |
| 53 | L1-SUS-XR1 | SUS | X End Remote Electronics Rack | |
| 54 | L1-SUS-YC1 | SUS | Y End Common Electronics Rack | |
| 55 | L1-SUS-YC2 | SUS | Y End Common Electronics Rack | |
| 56 | L1-SUS-YR1 | SUS | Y End Remote Electronics Rack | |
| 57 | L1-ETR-02 | SUS | BSC Electronics Test Rack | BSC Electronics Test Rack |
| 58 | L1-ETR-03 | SUS | RM Electronics Test Rack | RM Electronics Test Rack |
| 59 | L1-ETR-06 | SUS | STS Huddle Electronics Test Rack | STS Huddle Electronics Test Rack |
| 60 | L1-VAC-R1 | VAC | Remote Electronics Rack | |
| 61 | L1-VAC-R2 | VAC | Remote Electronics Rack | |
| 62 | L1-VAC-R3 | VAC | Remote Electronics Rack | |
| 63 | L1-VAC-XR1 | VAC | X End Remote Electronics Rack | |
| 64 | L1-VAC-YR1 | VAC | Y End Remote Electronics Rack | |
| 65 | L1-VDC-C1 | VDC | DC Voltage Rack - CPR | |
| 66 | L1-VDC-C2 | VDC | DC Voltage Rack - CPR | |
| 67 | L1-VDC-C3 | VDC | DC Voltage Rack - CPR | |
| 68 | L1-VDC-C4 | VDC | DC Voltage Rack - CPR | |
| 69 | L1-VDC-C5 | VDC | DC Voltage Rack - CPR | |
| 70 | L1-VDC-C6 | VDC | DC Voltage Rack - CPR | |
| 71 | L1-VDC-C6 | VDC | DC Voltage Rack - CPR | |
| 72 | L1-VDC-XC1 | VDC | DC Voltage Rack - VEAX | |
| 73 | L1-VDC-XC2 | VDC | DC Voltage Rack - VEAX | |
| 74 | L1-VDC-YC1 | VDC | DC Voltage Rack - VEAY | |
| 75 | L1-VDC-YC2 | VDC | DC Voltage Rack - VEAY | |
| 76 | L1-MS1 | | | |
| 77 | L1-MS2 | | | |
| 78 | L1-MS3 | | | |
| 79 | L1-MS4 | | | |
| 80 | L1-MS5 | | | |
| 81 | L1-MS6 | | | |
| 82 | L1-DAQ-MS7 | DAQ | Front end computers | |
| 83 | L1-DAQ-MS8 | DAQ | Front end computers | |
| 84 | L1-DAQ-MS9 | DAQ | Front end computers | |
| 85 | L1-MS10 | | | |
| 86 | L1-MS11 | | | |
| 87 | L1-MS12 | | | |
| 88 | L1-MS13 | | | |
| 89 | L1-FAC-XC1 | FAC | Facilities - VEAX | |
| 90 | L1-FAC-YC1 | FAC | Facilities - VEAY | |

Electronics Racks - Counts and Accounting

| Subsystem | Count | Percent | MSR | CER / CPR | LVEA | CERX | VEAX | CERY | VEAY | Other | Comment |
|-------------------------|-------|---------|-----|-----------|------|------|------|------|------|-------|-------------------------|
| SUS | 20 | 39.22 | 0 | 8 | 6 | 2 | 1 | 2 | 1 | 0 | Suspensions |
| SEI | 8 | 15.69 | 0 | 6 | 0 | 1 | 0 | 1 | 0 | 0 | Seismic |
| ISC | 8 | 15.69 | 0 | 3 | 3 | 0 | 1 | 0 | 1 | 0 | IFO Sensing and Control |
| PEM / DAQ | 3 | 5.88 | 3 | 1 | 0 | 1 | 0 | 1 | 0 | 0 | Data Acquisition |
| AOS - TCS | 7 | 13.73 | 0 | 1 | 2 | 1 | 1 | 1 | 1 | 0 | Thermal Compensation |
| PSL / LDR | 5 | 9.80 | 0 | 3 | 2 | 0 | 0 | 0 | 0 | 0 | Pre-stabilized Laser |
| Subsystem Subtotal | 51 | 100.00 | 3 | 22 | 13 | 5 | 3 | 5 | 3 | 0 | |
| Infrastructure | Count | | MSR | CER / CPR | LVEA | CERX | VEAX | CERY | VEAY | Other | Comment |
| DC Power | 11 | | 0 | 7 | 0 | 2 | 0 | 2 | 0 | 0 | DC Power Supplies |
| MSR | 13 | | 10 | 0 | 0 | 0 | 0 | 0 | 0 | 13 | MSR Racks |
| Vacuum | 5 | | 0 | 0 | 3 | 0 | 1 | 0 | 1 | 0 | Vacuum Racks |
| Facilities | 2 | | 0 | 0 | 0 | 1 | 0 | 1 | 0 | 0 | Facilities Racks |
| Test Racks | 7 | | 0 | 0 | 0 | 0 | 0 | 0 | 0 | 7 | Subsystem Test Racks |
| Infrastructure Subtotal | 38 | | 10 | 7 | 3 | 3 | 1 | 3 | 1 | 20 | |
| Total | 89 | | 13 | 29 | 16 | 8 | 4 | 8 | 4 | 20 | |

| Subsystem | Supply Count | Percent | % |
|-----------|--------------|---------|-----|
| SUS | 50 | 29.07 | 29 |
| SEI | 40 | 23.26 | 23 |
| ISC | 33 | 19.19 | 19 |
| DAQ | 13 | 7.56 | 8 |
| AOS | 25 | 14.53 | 15 |
| PSL | 11 | 6.40 | 6 |
| Total | 172 | 100.00 | 100 |

[<< Start](#)

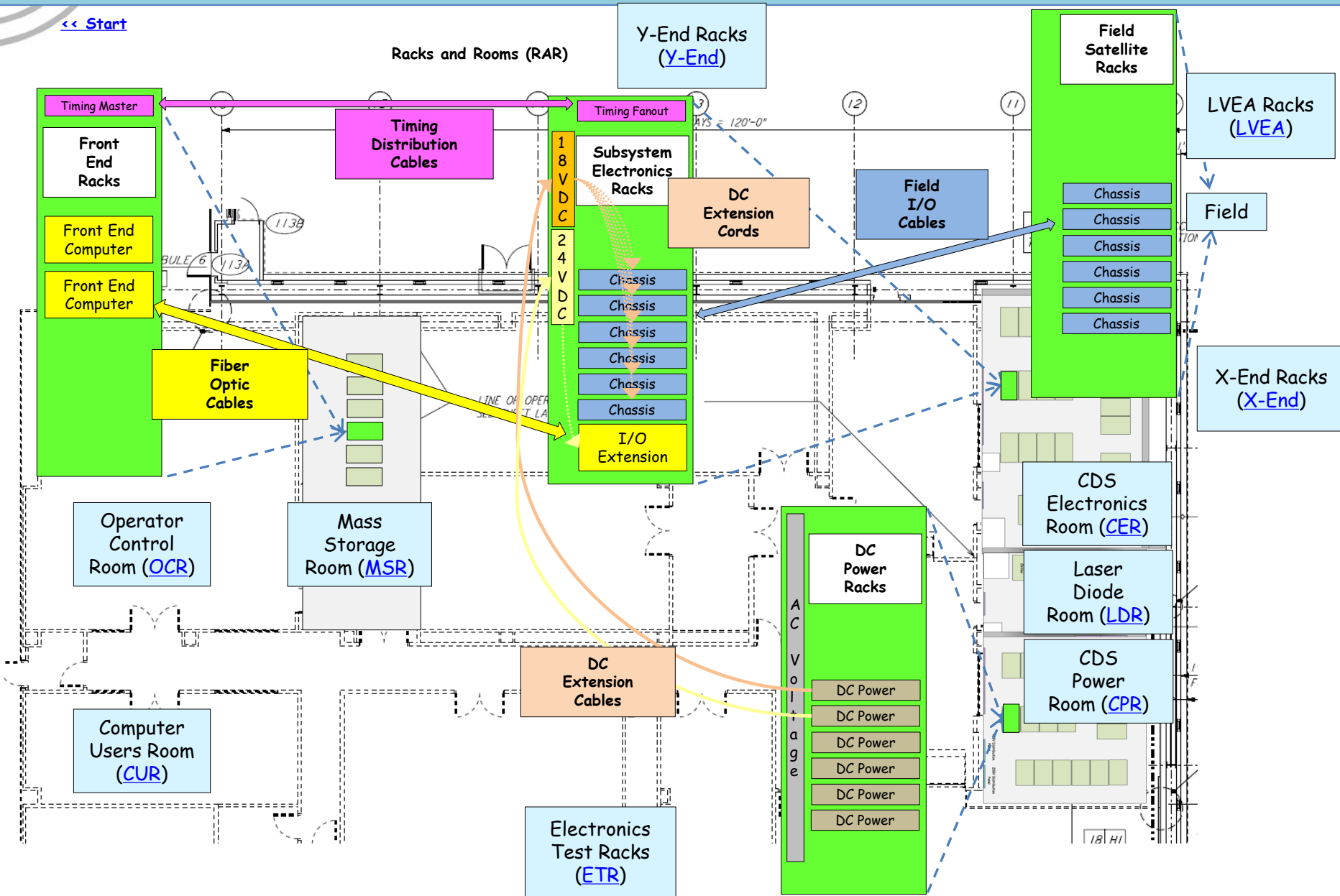

[<< LLO Map](#)

[<< LLO Racks by AREA](#)

[<< LLO CDS Components](#)

OCR

[OCR Documentation](#)

[<< LLO Map](#)

[<< LLO Racks by AREA](#)

[<< LLO CDS Components](#)

CUR

[CUR Documentation](#)

[<< LLO Map](#)

[<< LLO Racks by AREA](#)

[<< LLO CDS Components](#)

MSR

[MSR Documentation](#)
[MSR Layout](#)

MSR (Mass Storage Room) Layout

[<< LLO Map](#)

[<< LLO Racks by AREA](#)

[<< LLO CDS Components](#)

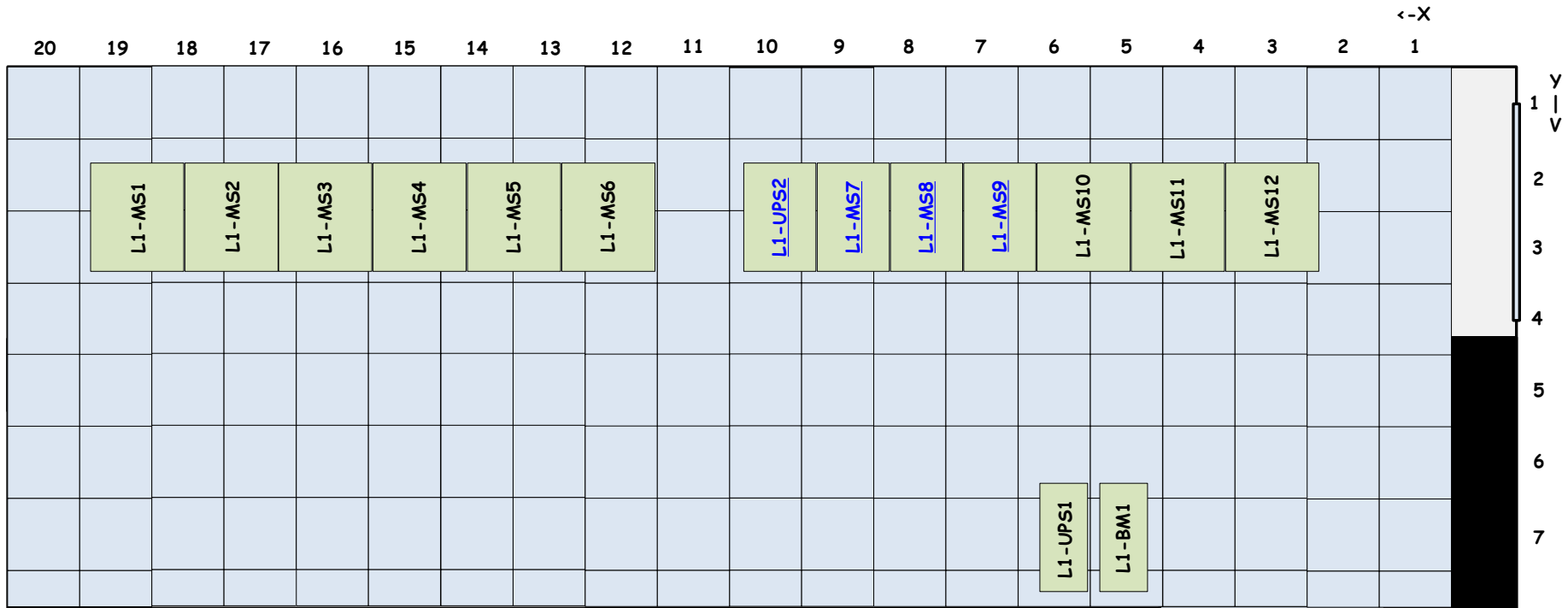
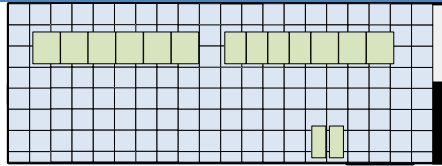

MSR (Mass Storage Room) Layout

- [<< LLO Map](#)
- [<< LLO Racks by AREA](#)
- [<< LLO CDS Components](#)

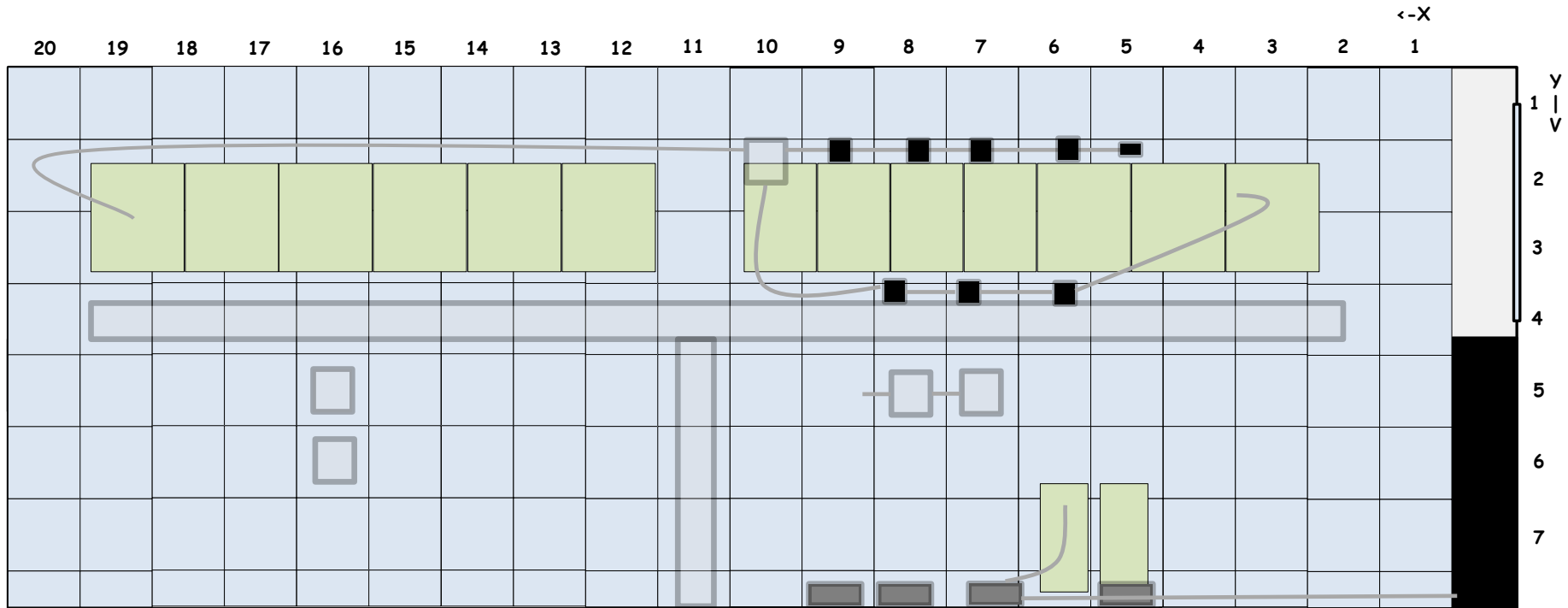
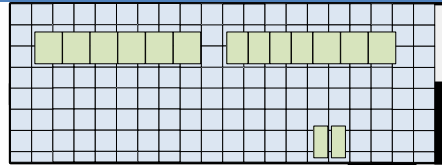



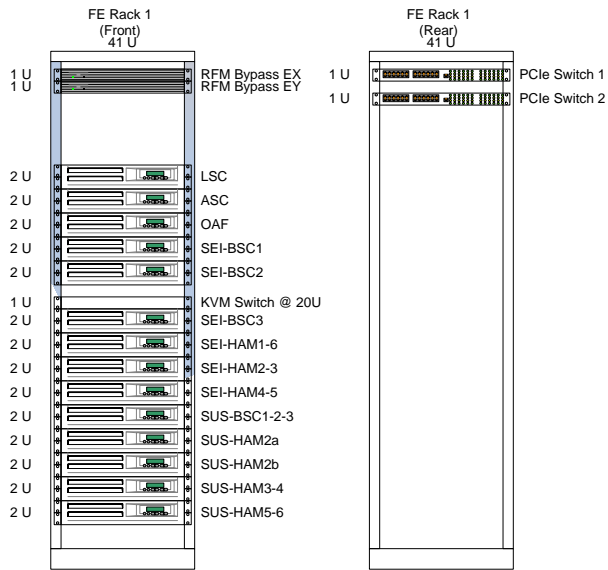

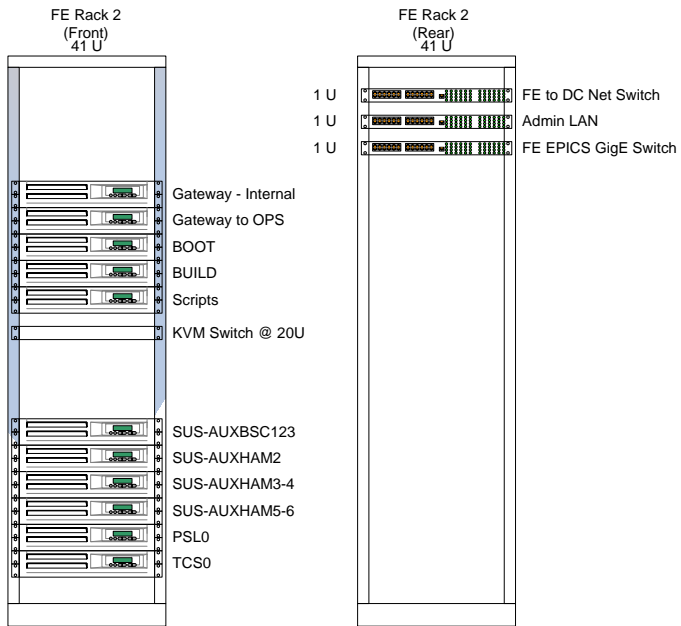

CDS MSR Rack 9 Layout ([LIGO-T1000588](#))

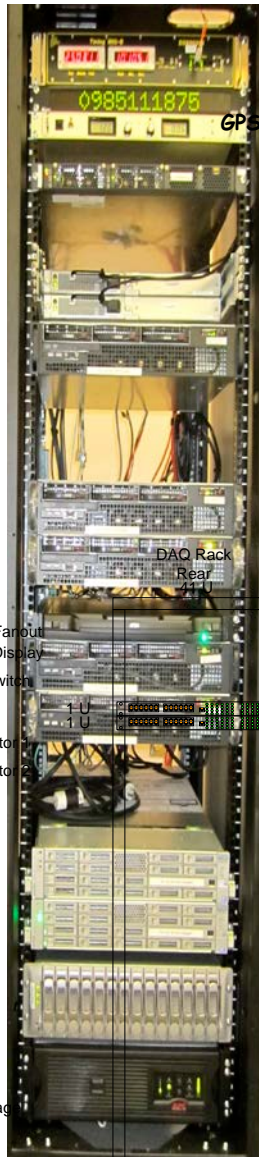

IRIG-B Chassis
GPS Seconds Display

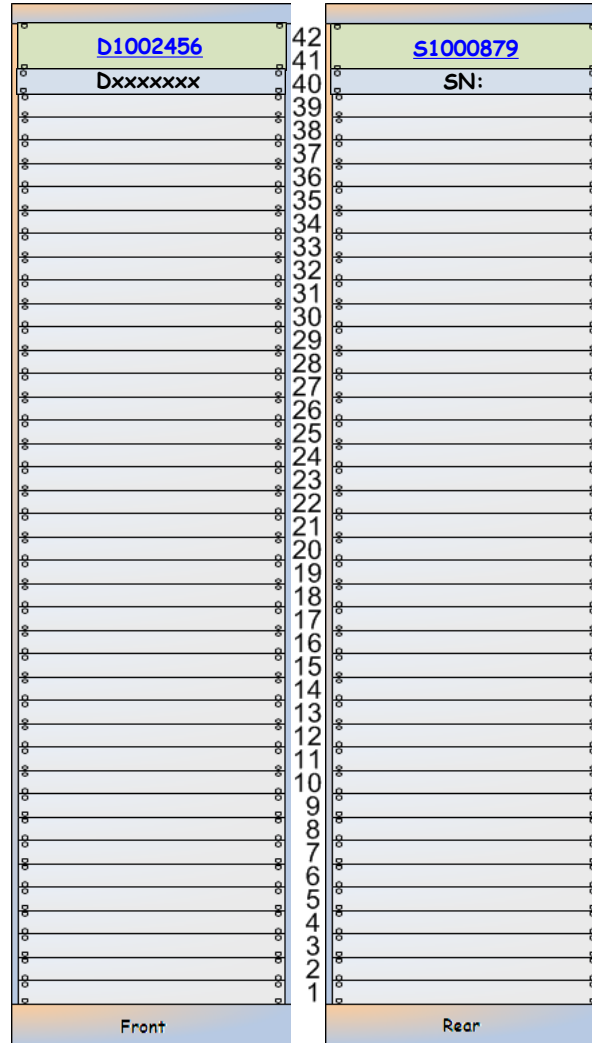
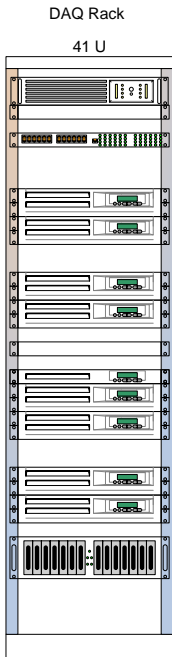

±12@1A; ±24@1A
±18@0.5A

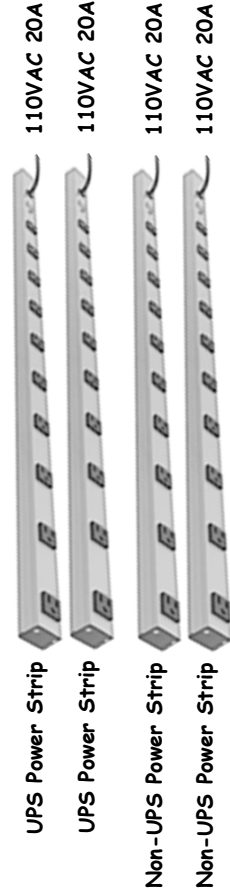

[<< LLO Map](#)

[<< LLO Racks by AREA](#)

[<< LLO CDS Components](#)

CER

[Rack Layout >>](#)

<< LLO Map

<< LLO Racks by Area

<< LLO CDS Components

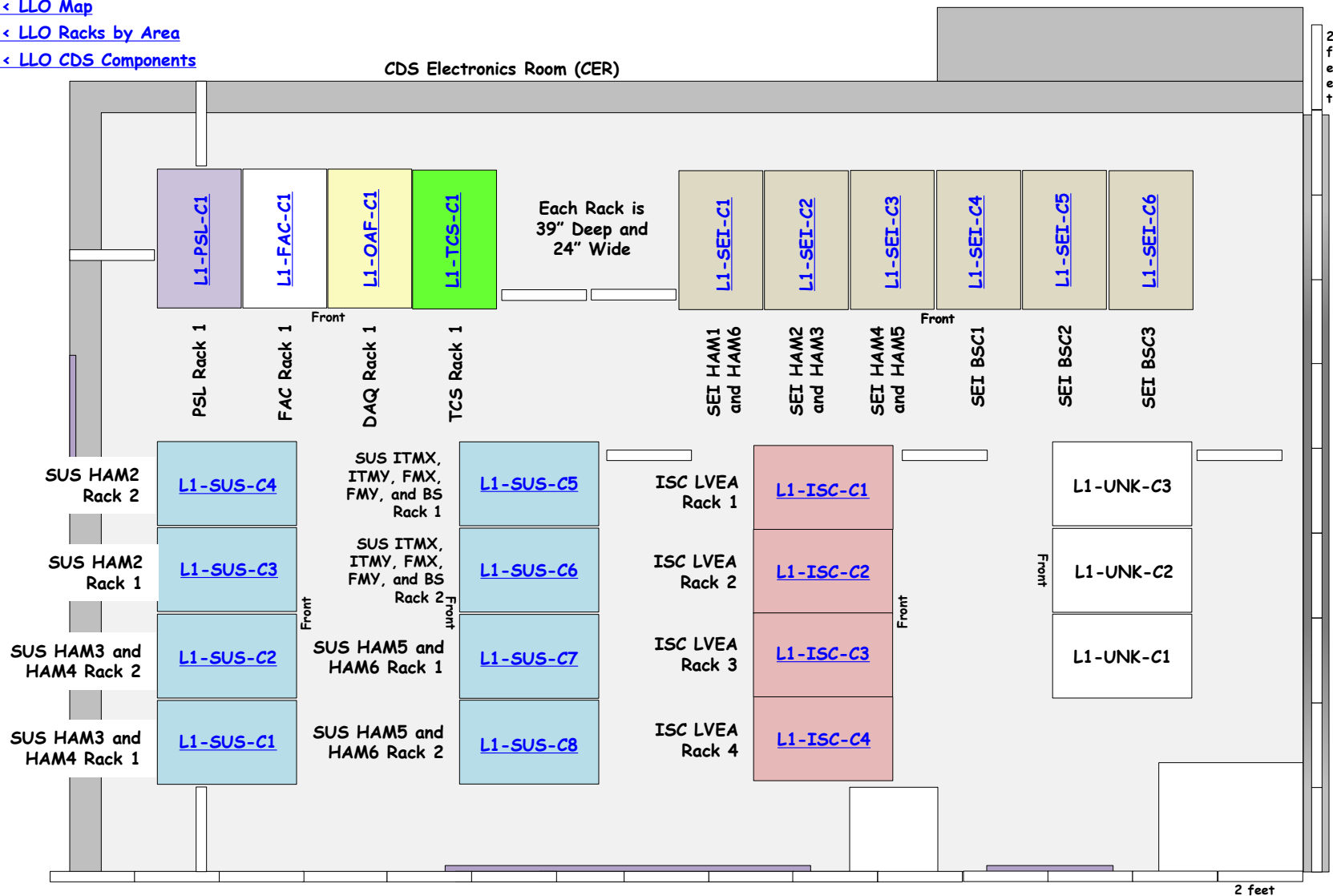

LLO CER, LDR, and CPR Cable Tray Layout

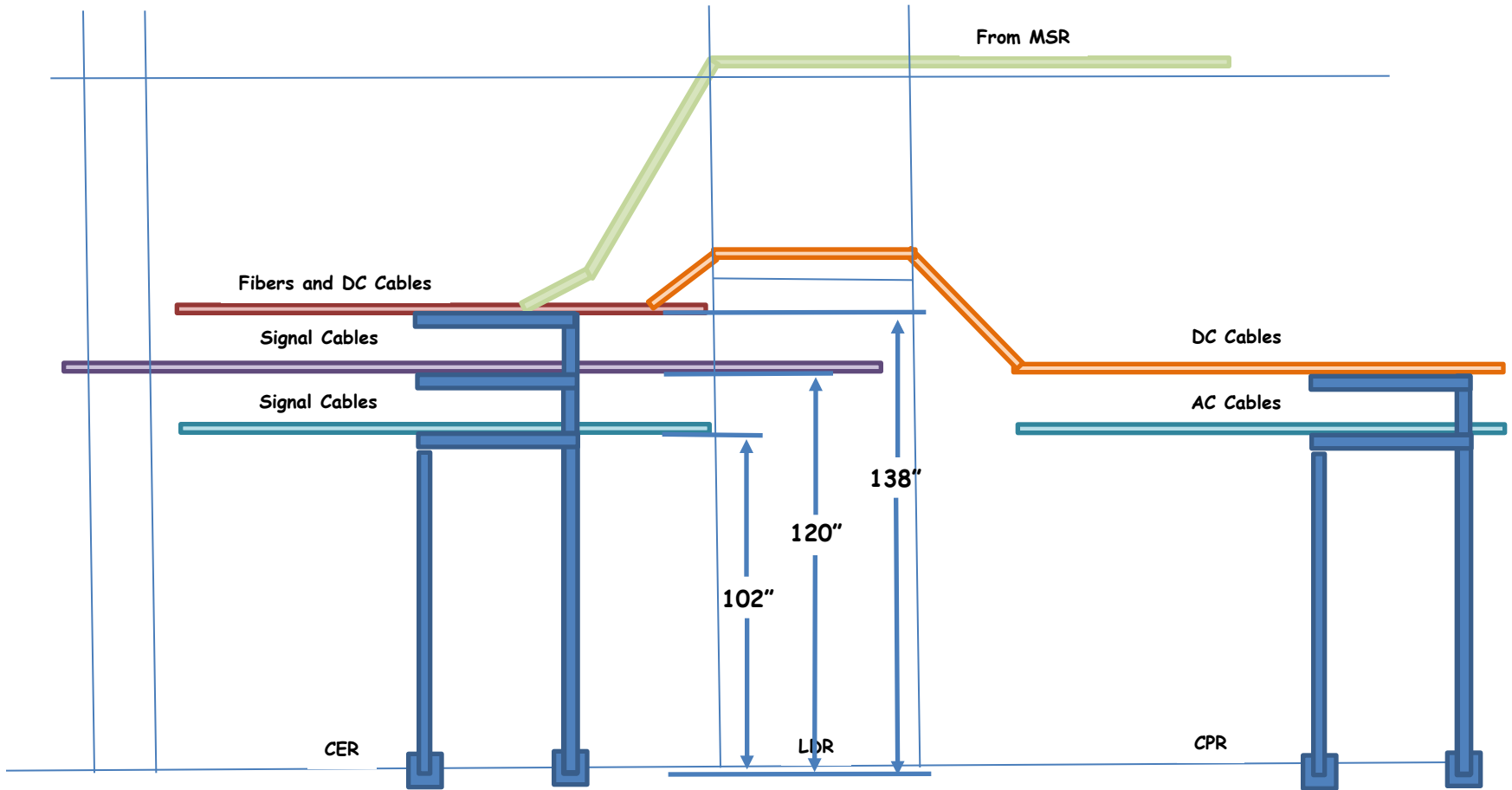

LLO CER - 8.5ft Cable Tray Layout

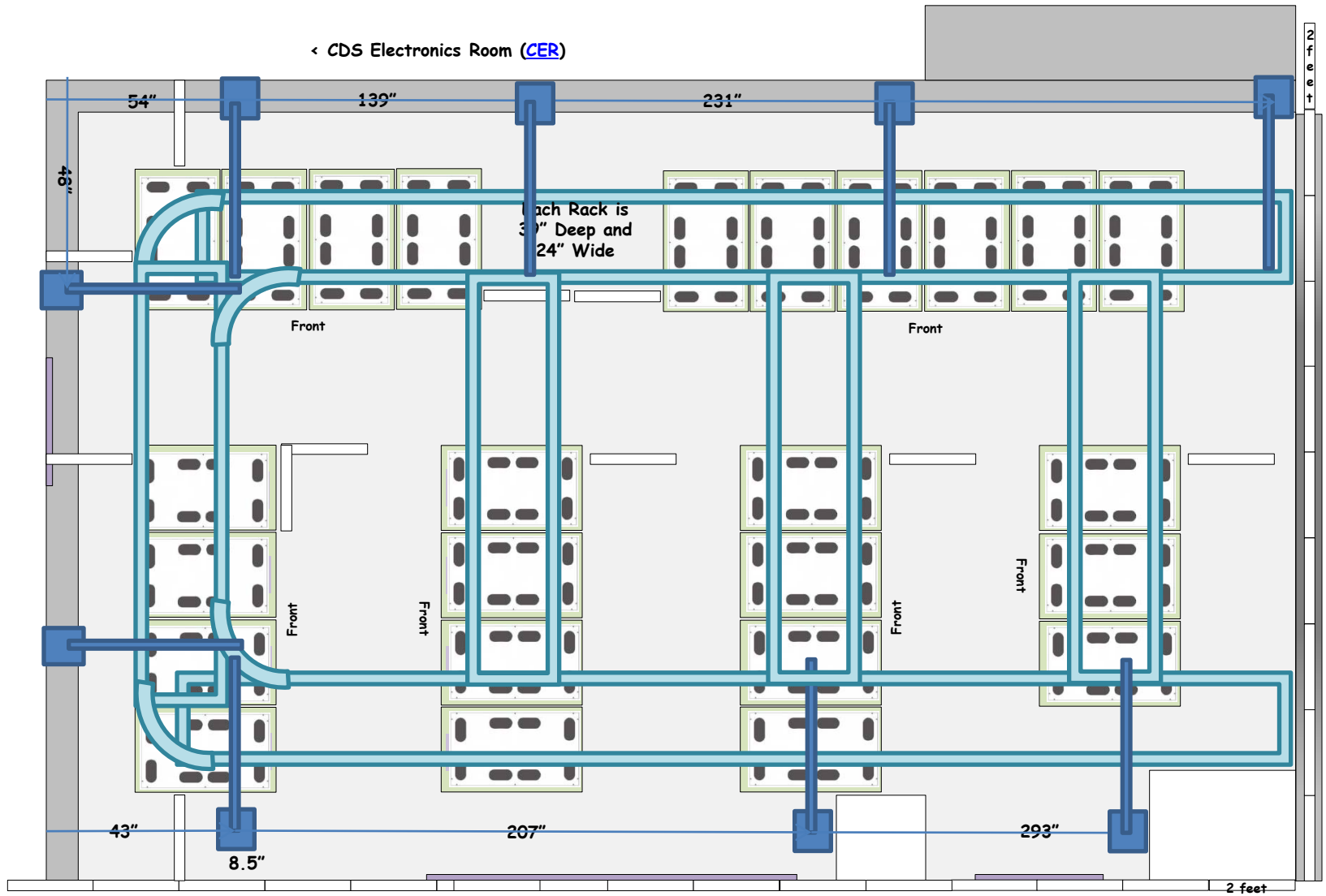

All posts are E-Posts

LIGO CER - 10ft Cable Tray Layout

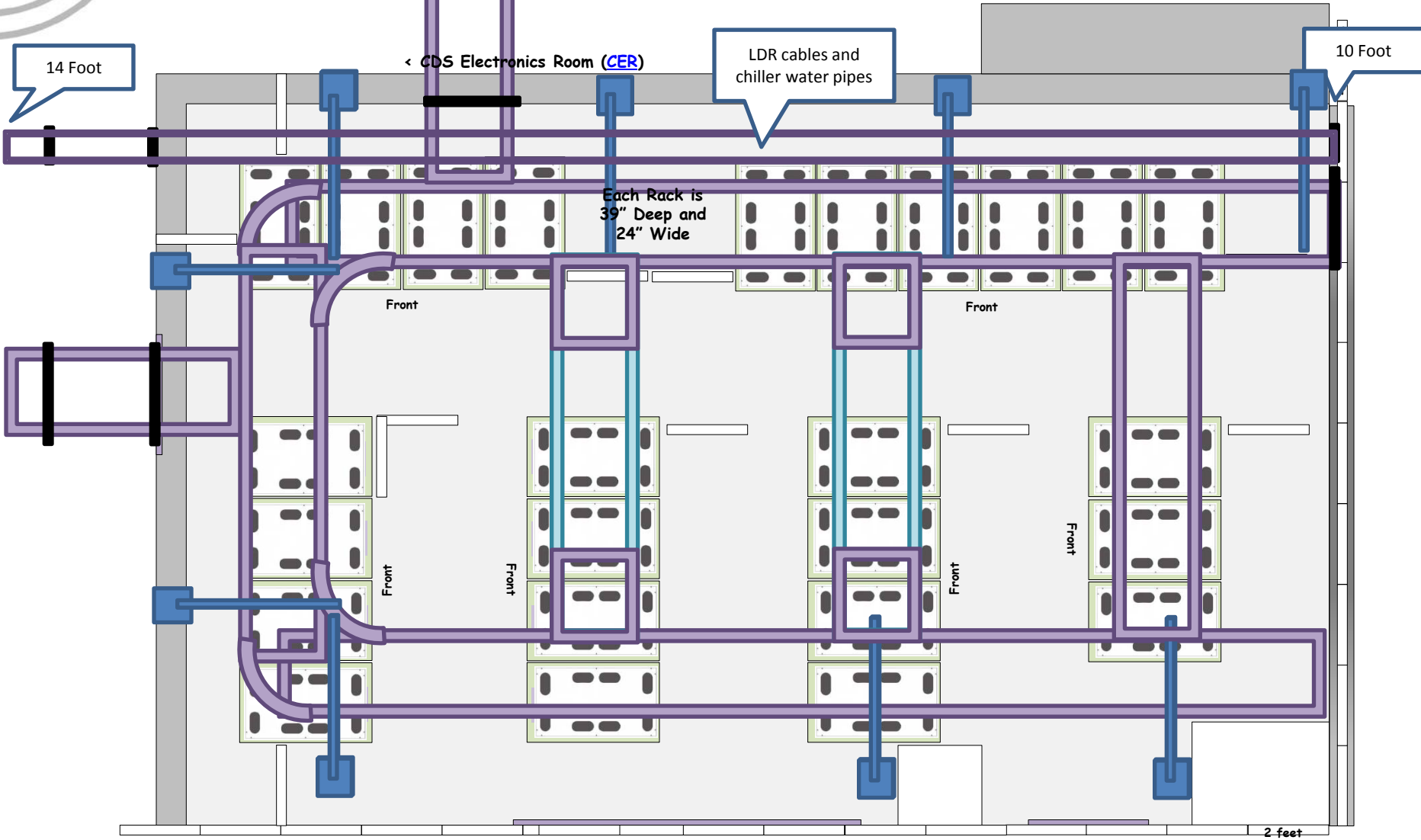

All posts are E-Posts

LLO CER - 11.5ft Cable Tray Layout

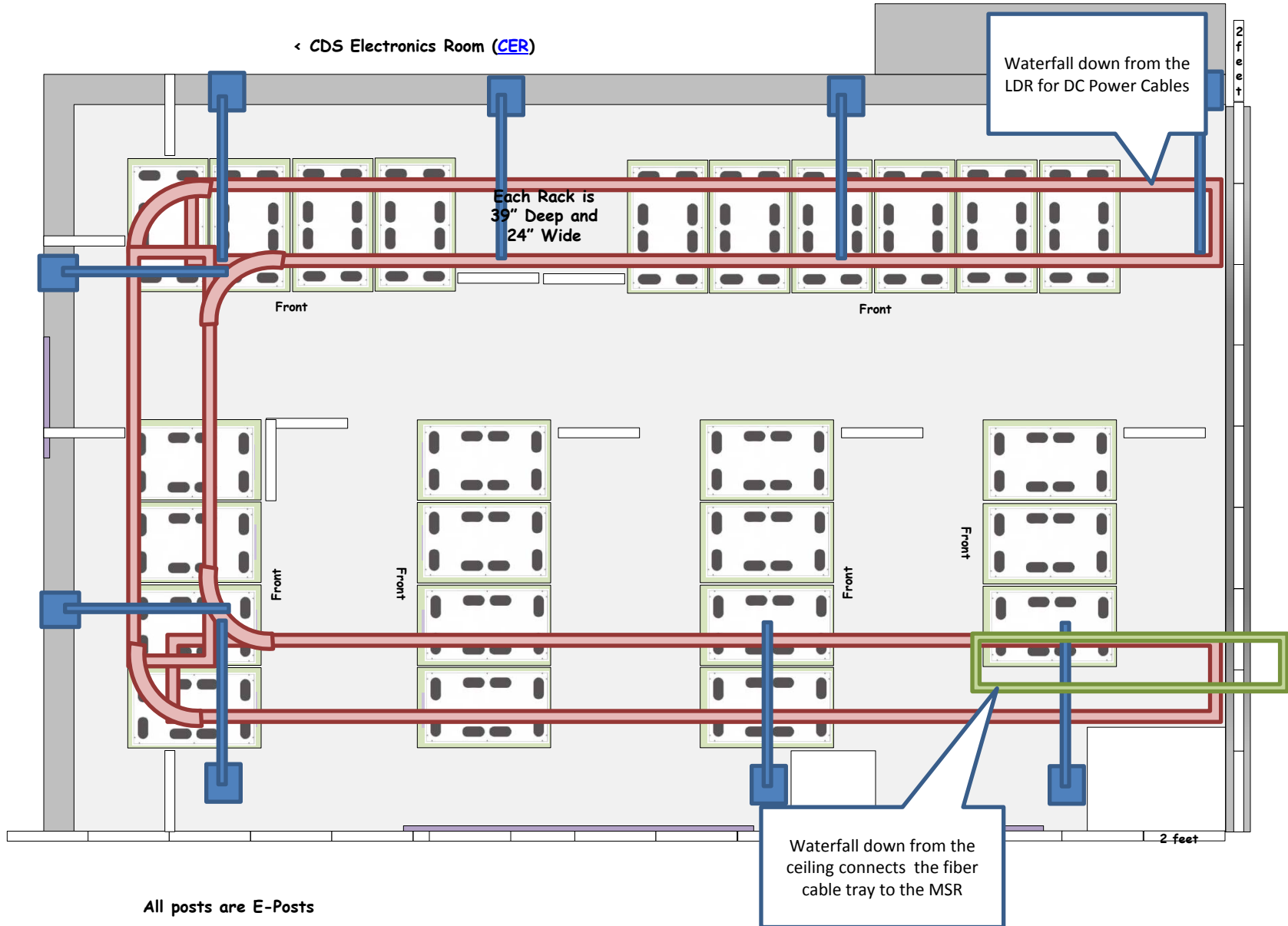

LLO CER - Rack Layout

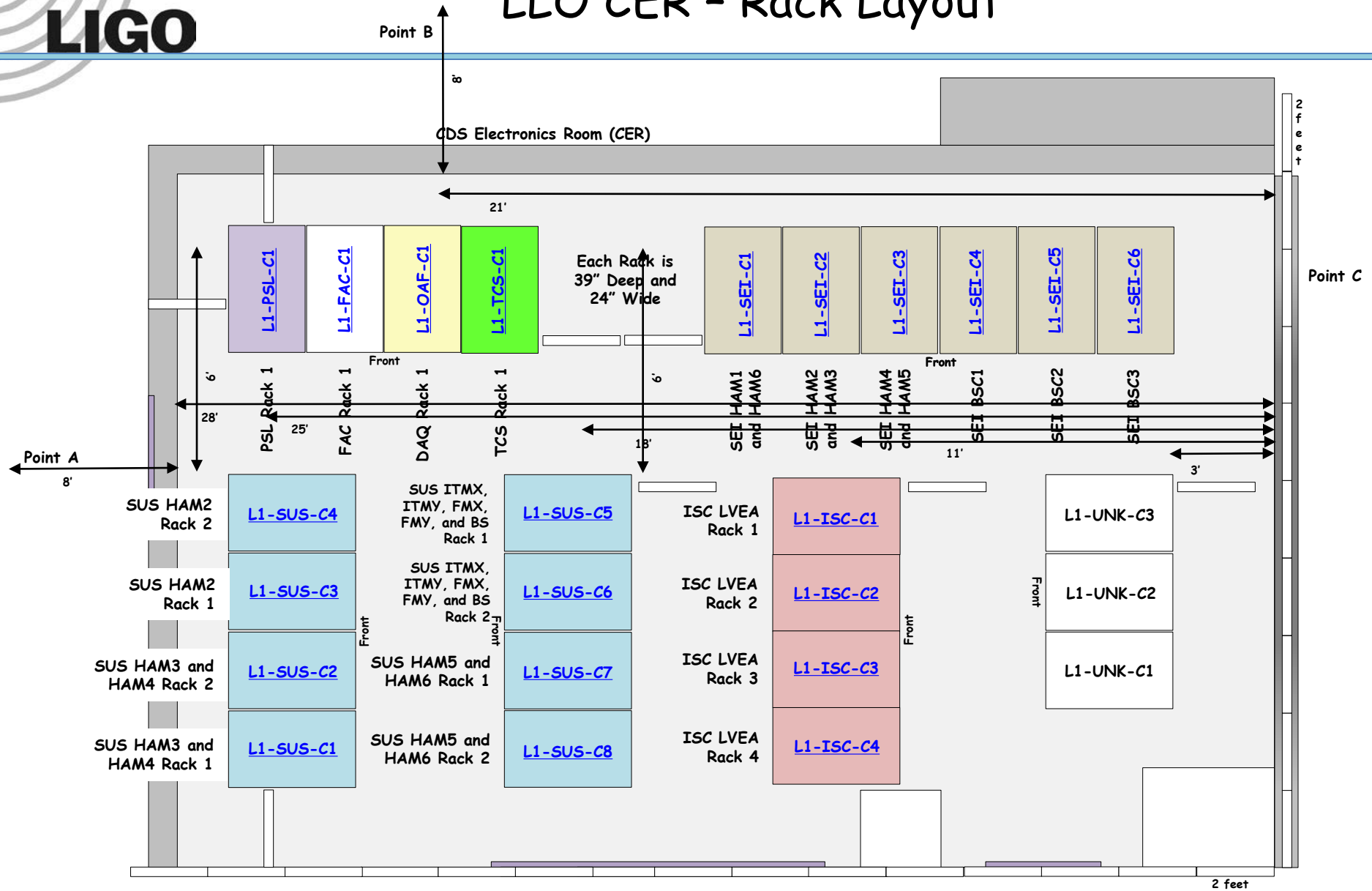

[<< LLO Map](#)

[<< LLO Racks by AREA](#)

[<< LLO CDS Components](#)

LDR

- << [LLO Map](#)
- << [LLO Racks by AREA](#)
- << [LLO CDS Components](#)

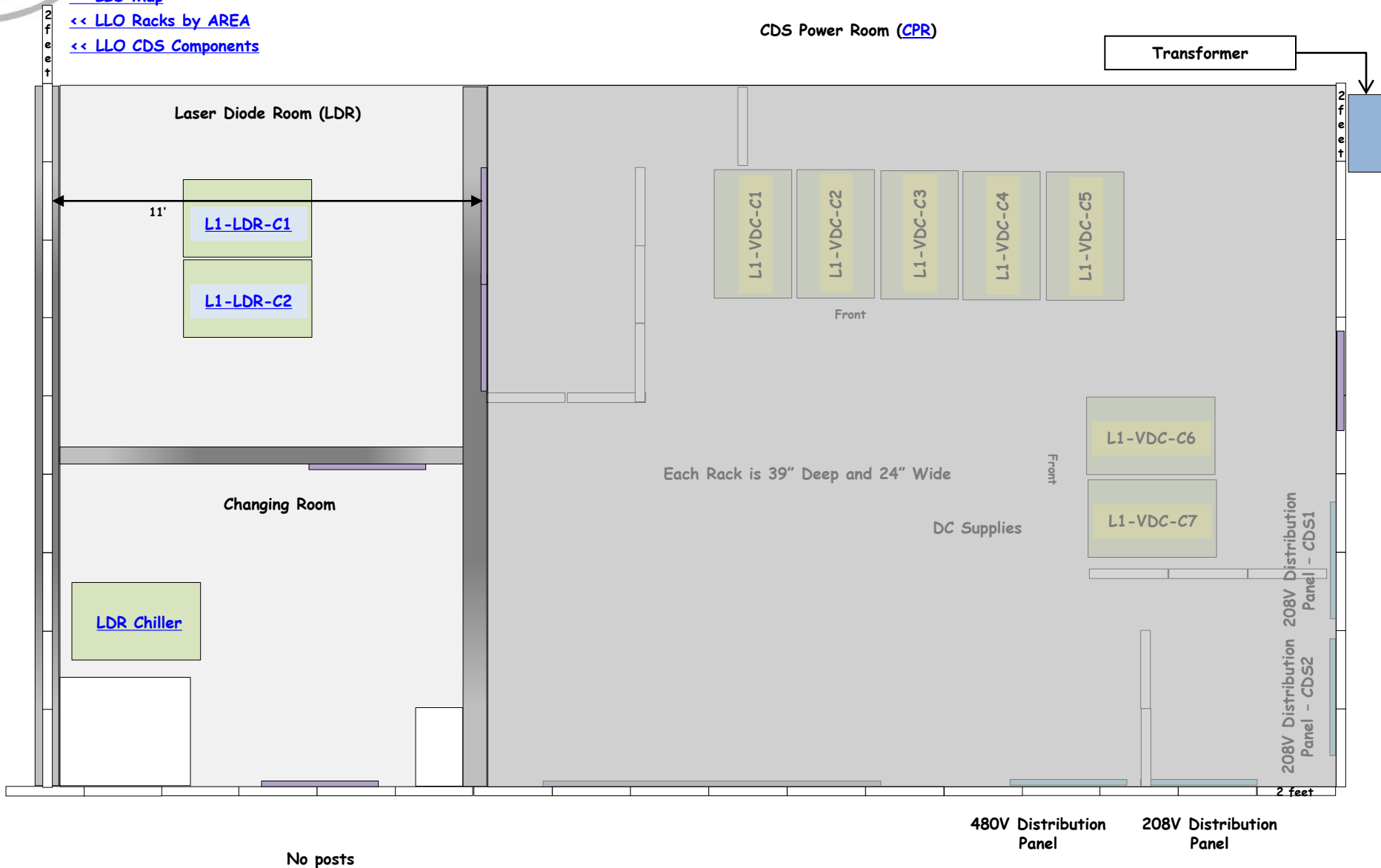

LLO LDR - 10ft Cable Tray Layout

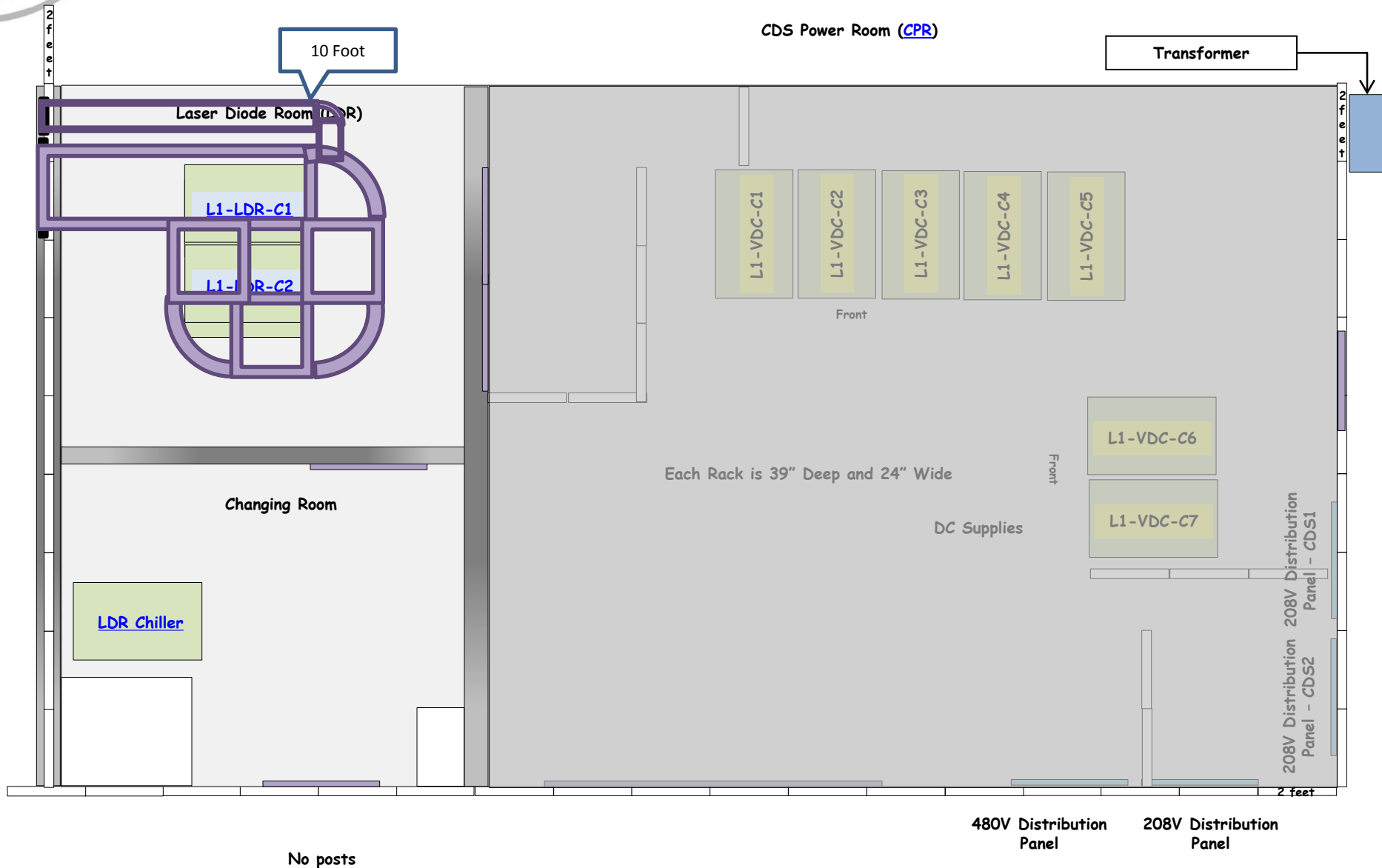

[<< LLO Map](#)

[<< LLO Racks by AREA](#)

[<< LLO CDS Components](#)

CPR

LLO CPR - Rack Layout

- [<< LLO Map](#)
- [<< LLO Racks by AREA](#)
- [<< LLO CDS Components](#)

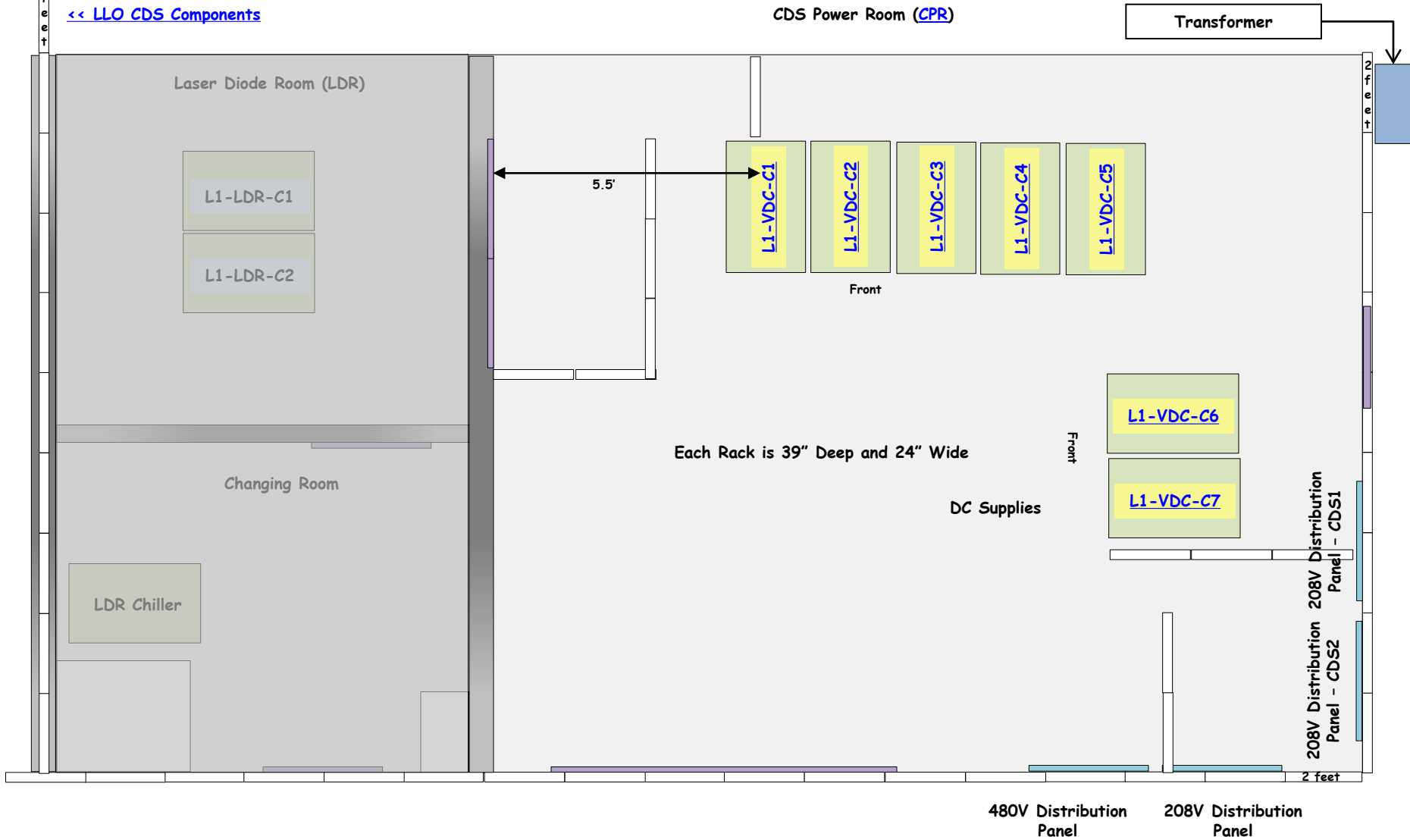

LLO CPR - 8.5ft (AC) Cable Tray Layout

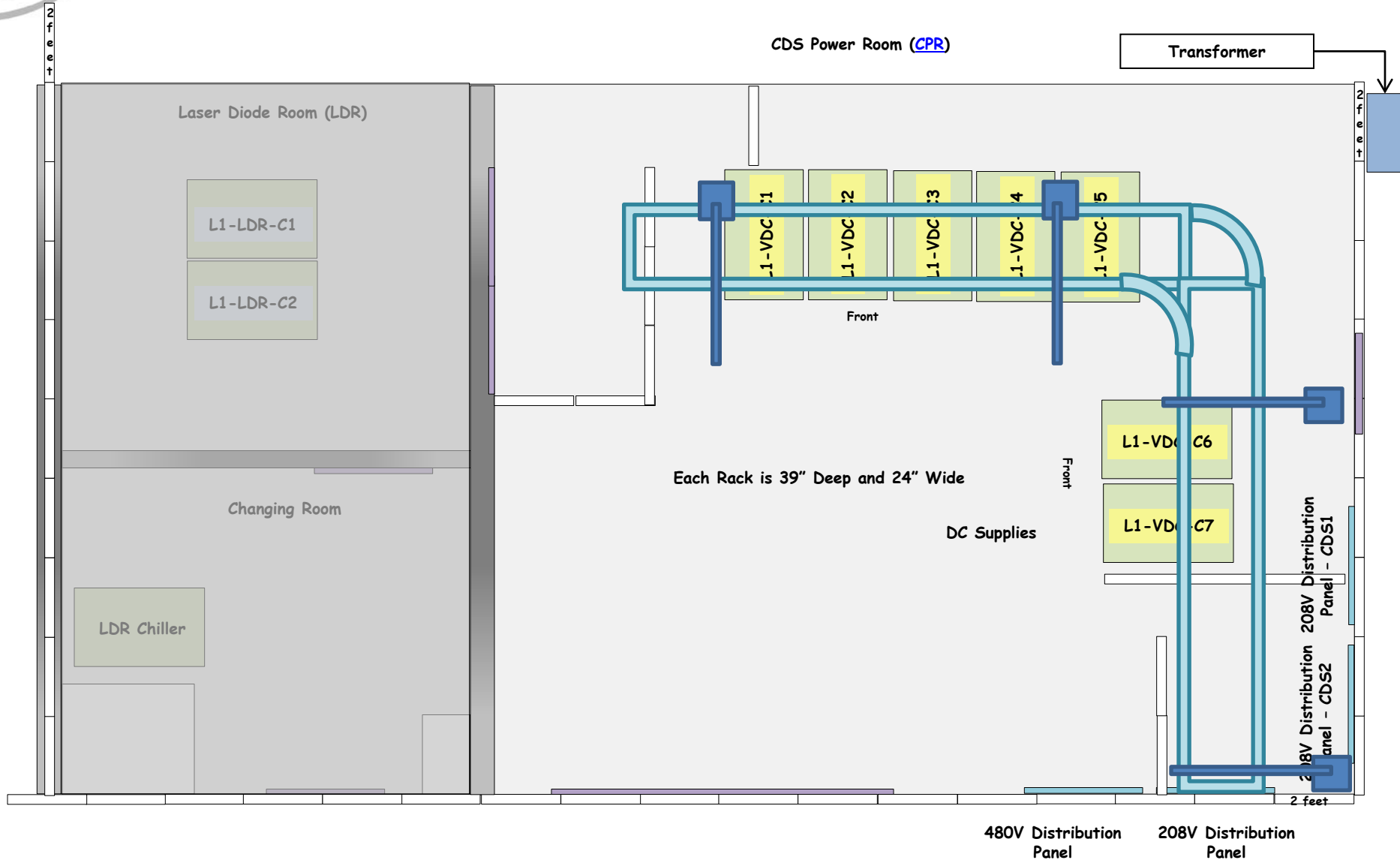

LLO CPR - 10ft (DC) Cable Tray

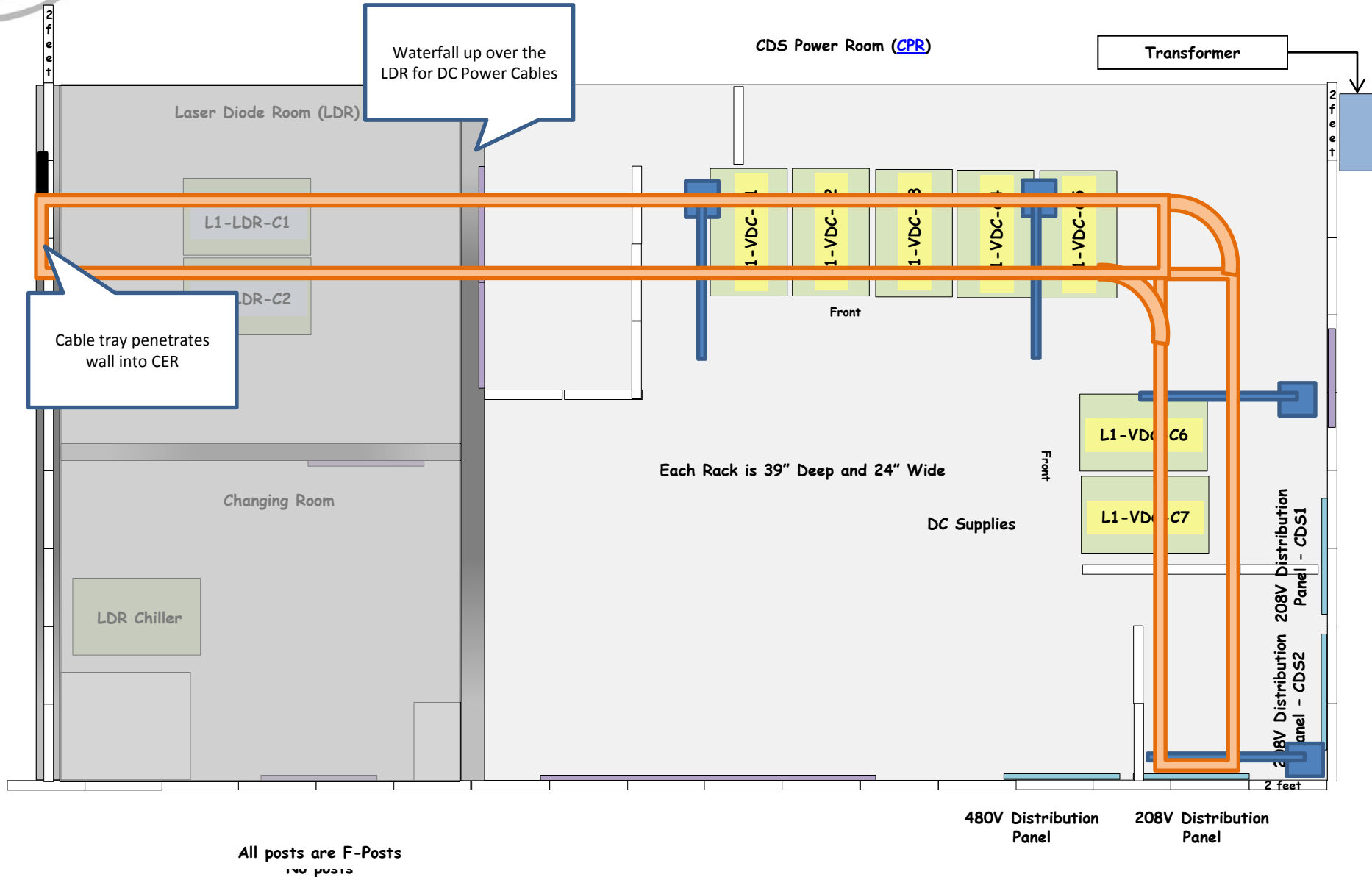

[<< LLO Map](#)

[<< LLO Racks by AREA](#)

[<< LLO CDS Components](#)

[<< IFO Subsystems](#)

VDC

[DC Power Supplies >>](#)

[CPR Rack Layout >>](#)

[CERX DC Rack Layout >>](#)

[CERY DC Rack Layout >>](#)

[KEPCO BHK500-80MG](#)

[KEPCO JQE25-20MVPY27274](#)

[KEPCO JQE36-30M](#)

Picture: Front Panel

Picture: Rear Panel

Specifications

Inventory of Serial Numbers / Dates received / scheduled
maintenance / assigned use / etc.

Acceptance Testing: LIGO-Txxxxxxx

Picture: Front Panel

Picture: Rear Panel

Specifications

Inventory of Serial Numbers / Dates received / scheduled
maintenance / assigned use / etc.

Acceptance Testing: [LIGO-T1100478](#)

Picture: Front Panel

Picture: Rear Panel

Specifications

**Inventory of Serial Numbers / Dates received / scheduled
maintenance / assigned use / etc.**

Acceptance Testing: LIGO-Txxxxxxx

DC Power Rack - Required VDC

<< CPR

5 Standard Banks
per Rack

10 x 4U => 40U

DC Power Rack

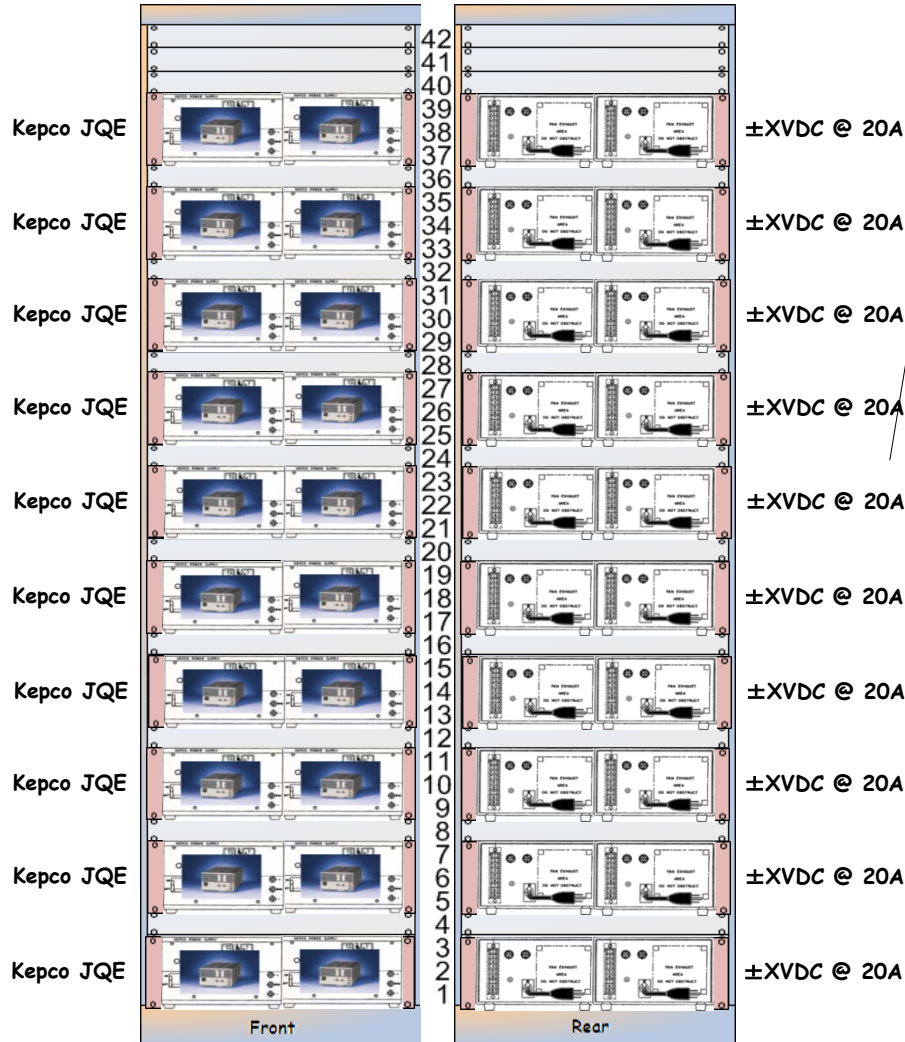

A Standard Bank (SB) of power supplies consists of 4 supplies, and services 1 Electronics Rack.

The 4 supplies are:
+18V@20A, -18V@20A,
+24V@20A, and -24V@20A.

Each Standard Bank of DC Power Supplies provides

$18V * 20A \Rightarrow 360W$
 $360W * 2 PS \Rightarrow 720W$
 $24V * 20A \Rightarrow 480W$
 $480W * 2 PS \Rightarrow 960W$
 $720W + 960W \Rightarrow 1680W$

There are 5 SB (20 PS) / Power Rack. Each Power Rack therefore provides 8400W

Each Power Rack services 5 Electronics Racks.

There are roughly 22 racks per interferometer.

Therefore 5 DC Power Racks are required and will **provide** for a total of 42,000 W.

DC Power Rack - Required VAC

<< CPR

5 Standard Banks
per Rack

10 x 4U => 40U

DC Power Rack

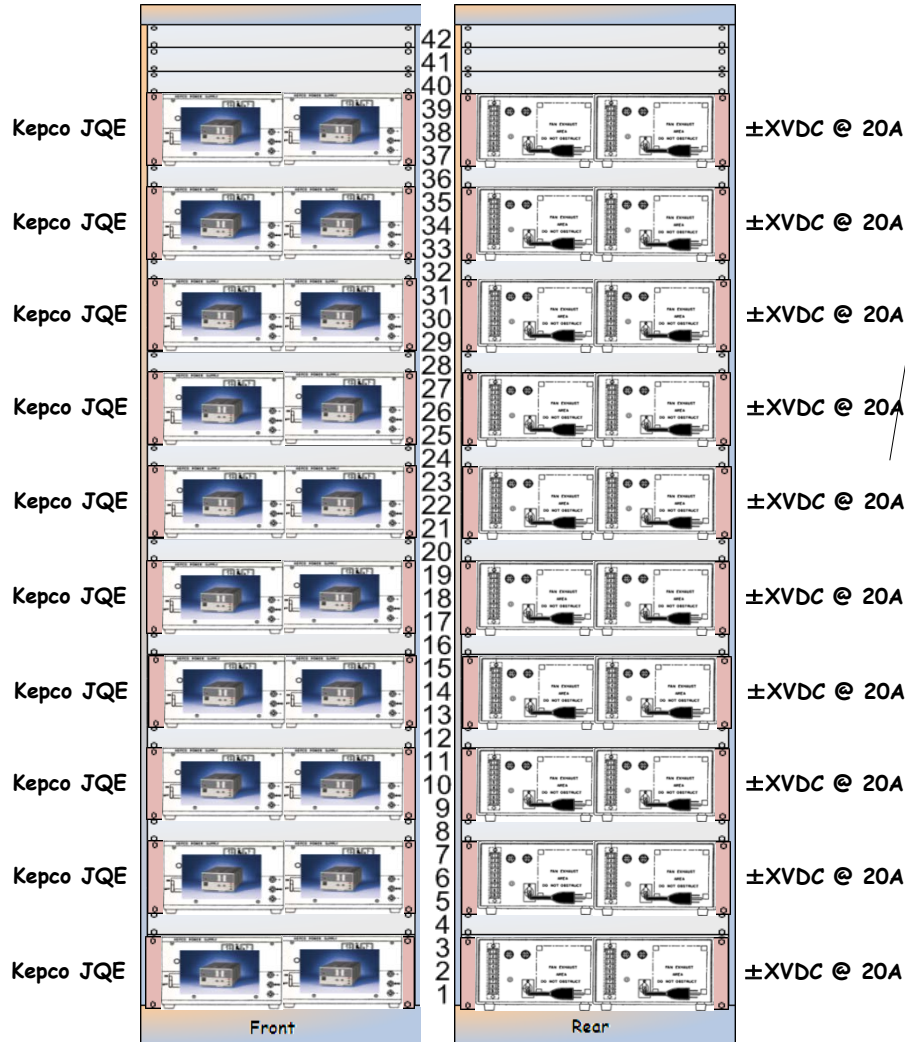

A Standard Bank (SB) of power supplies consists of 4 supplies, and services 1 Electronics Rack.

The 4 supplies are:
+18V@20A, -18V@20A,
+24V@20A, and -24V@20A.

Each (~JQE25-20M) DC Power Supply requires 10.5A @ 125VAC

Each Standard Bank of DC Power Supplies requires 42A @ 125VAC

There are 5 SB (20 PS) / Power Rack. Each Power Rack therefore requires 210A @ 125VAC.

10 - 125V@20A circuits per Power Rack should suffice.

Each Power Rack services 5 Electronics Racks.

There are roughly 22 racks per interferometer.

70 - 125V @20A circuits are required for a total of 183,750W.

Therefore 2 - 480VAC * 200A circuits would provide 192,000W

DC Power Rack

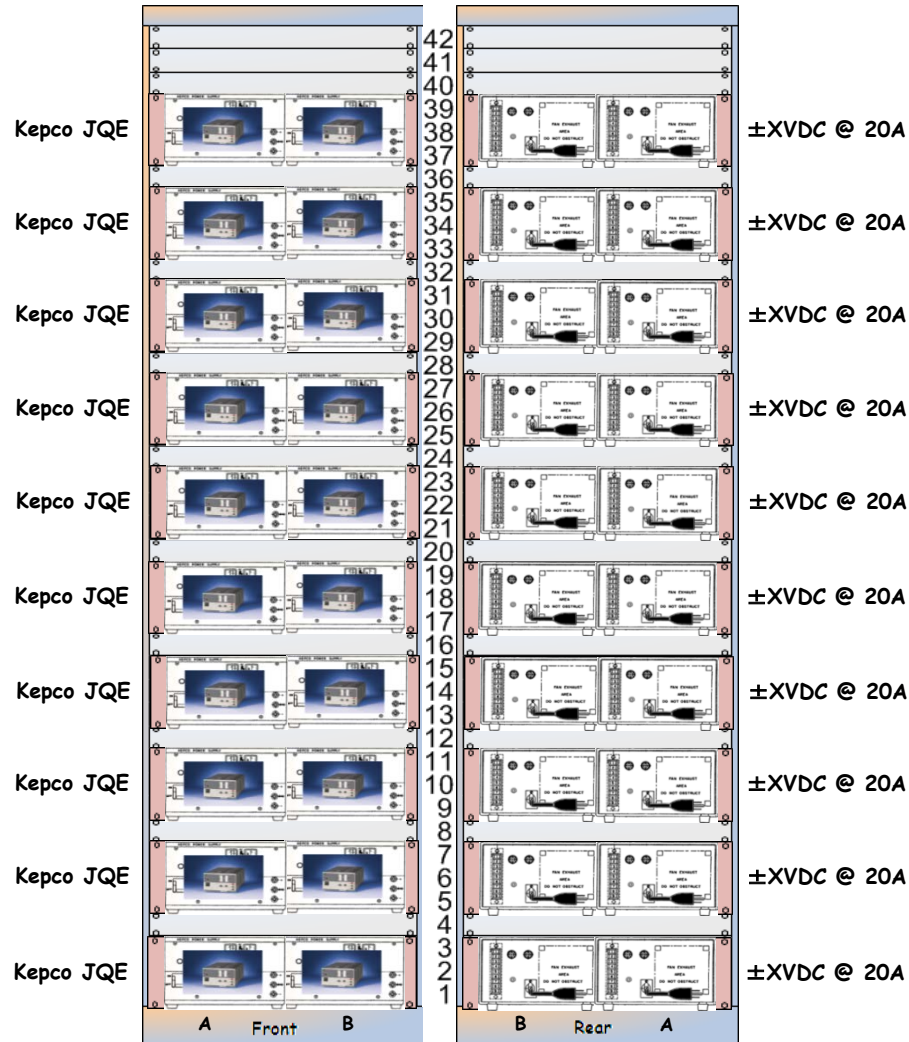

12 @ 125V, 20A Circuits per Rack

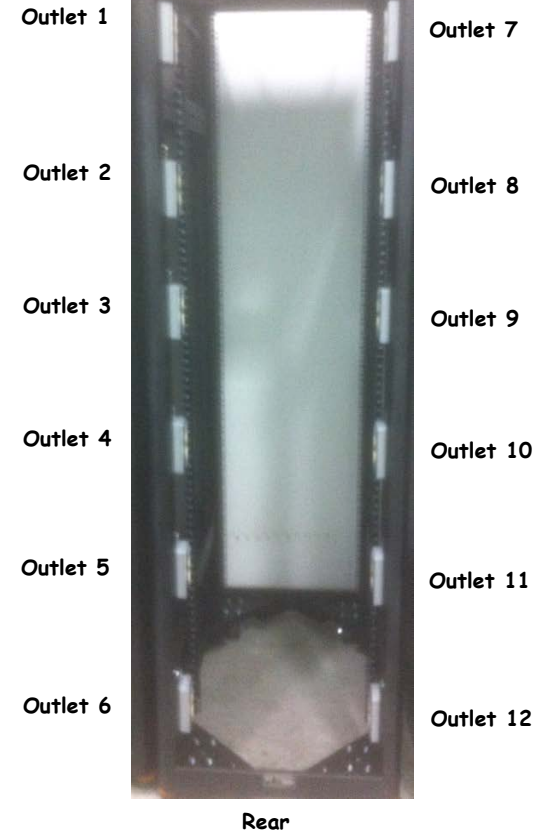

L1-VDC-C1 Power Racks - Required Supplies

<< CPR

D1200890
S1105247

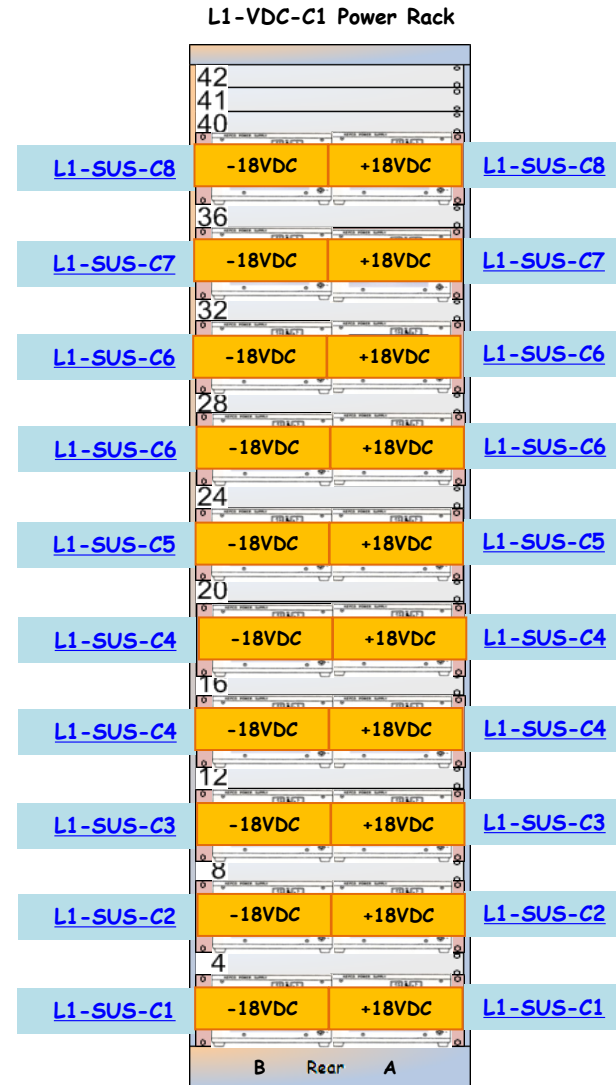
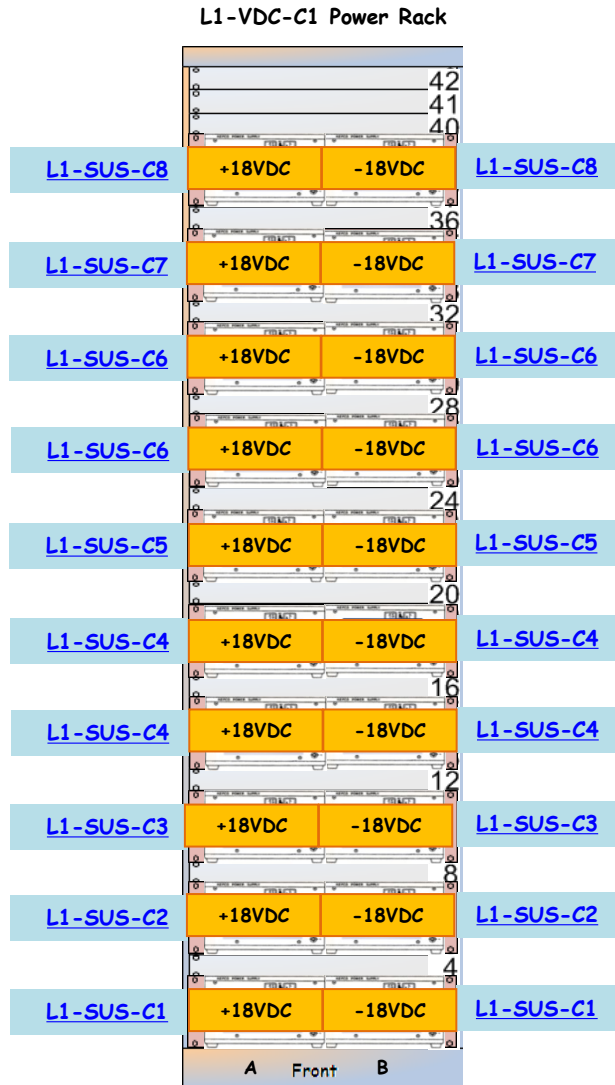

[Cable Runs >>](#)

L1-VDC-C2 Power Racks - Required Supplies

D1200891
S1105248

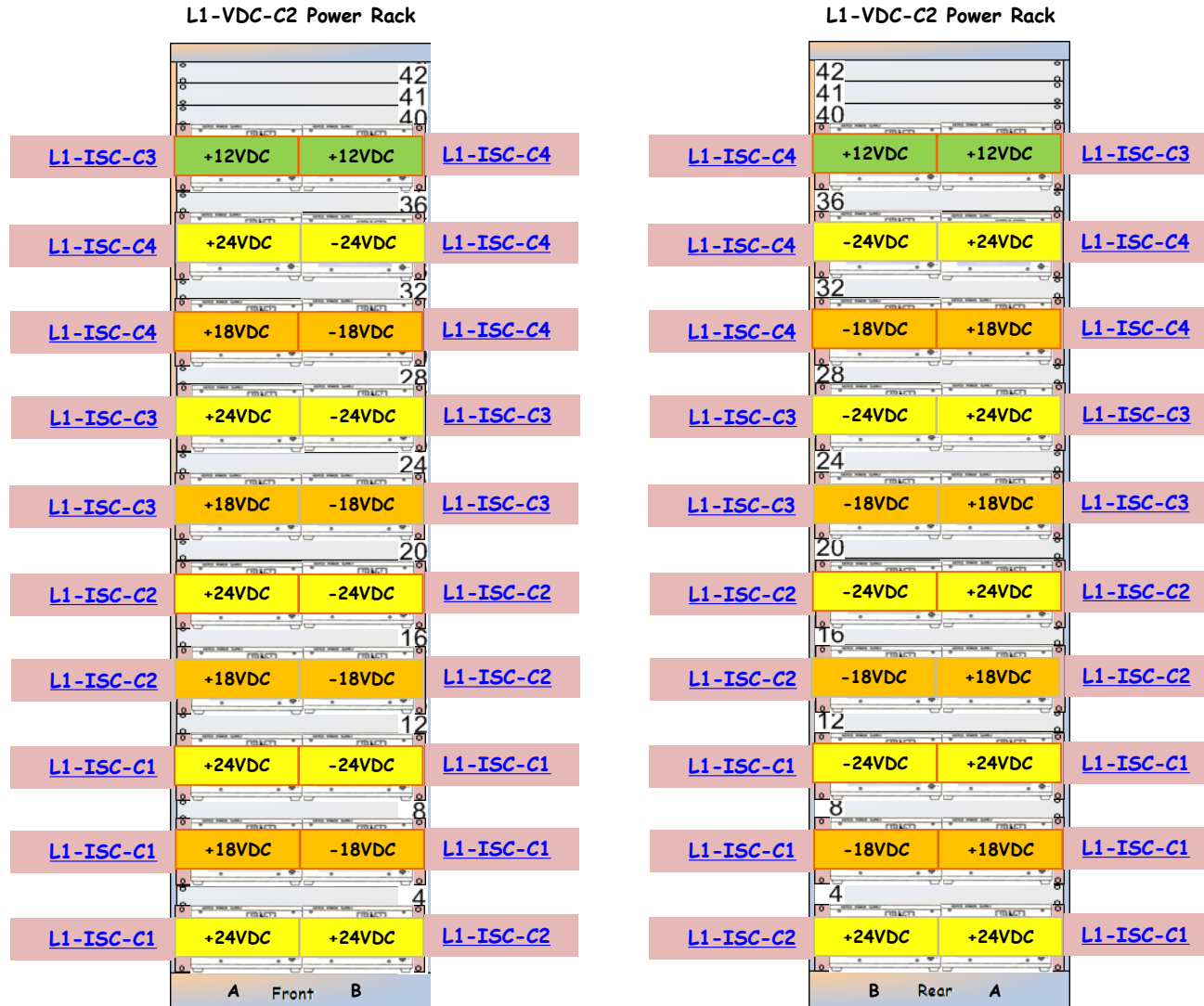

[Cable Runs >>](#)

L1-VDC-C3 Power Racks - Required Supplies

D1200892

S1105249

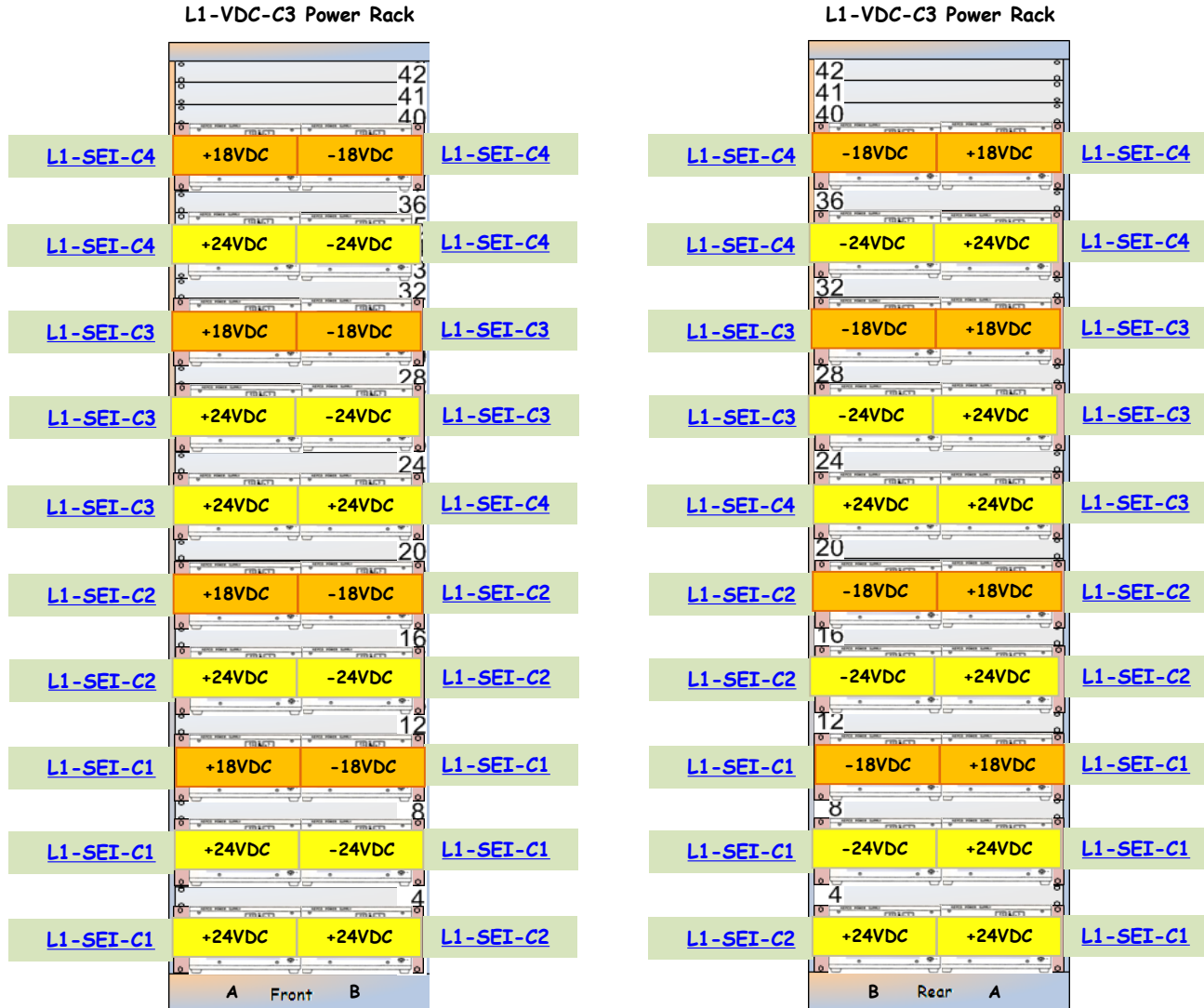

[Cable Runs >>](#)

L1-VDC-C4 Power Racks - Required Supplies

D1200893
S1105250

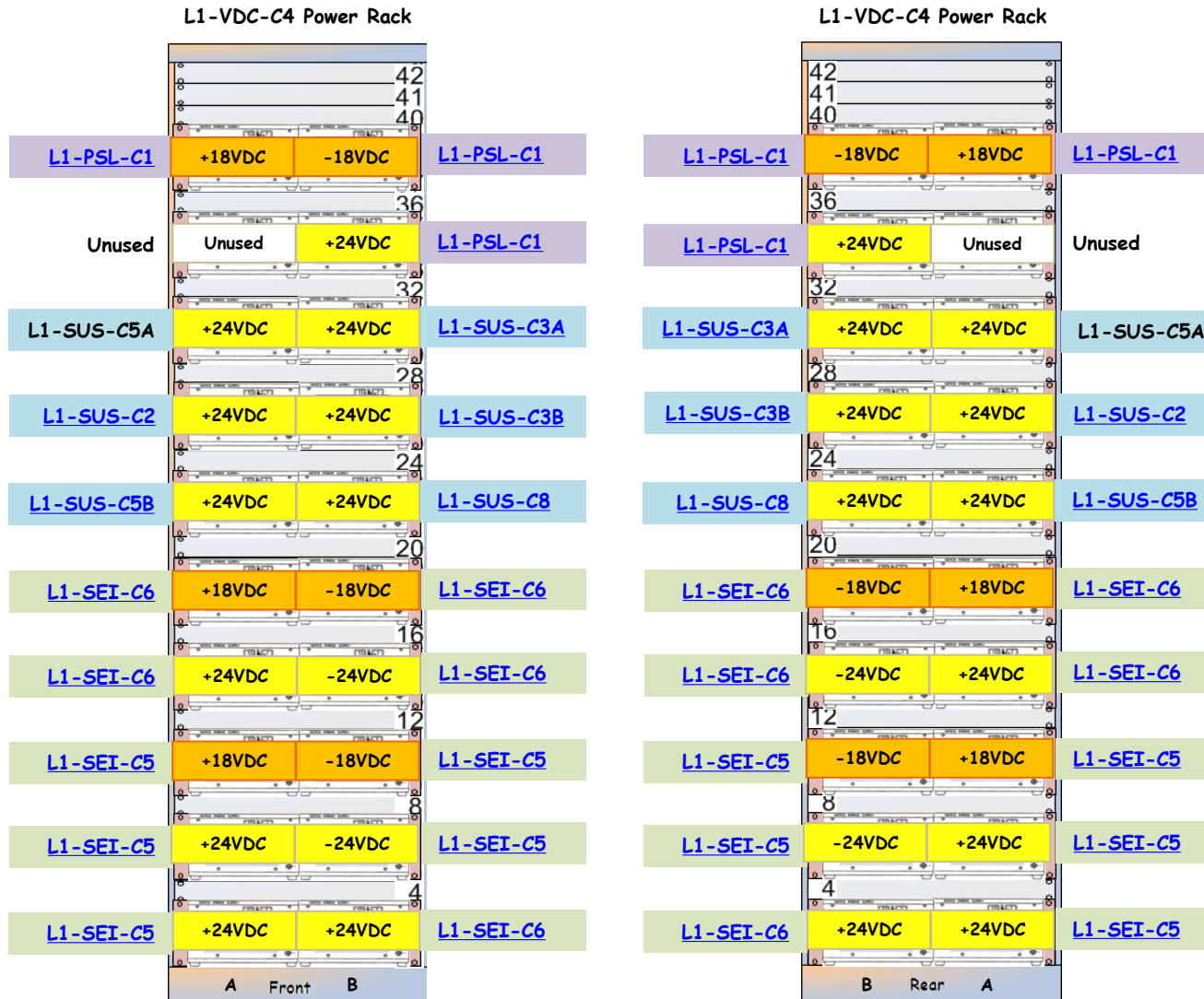

[Cable Runs >>](#)

L1-VDC-C5 Power Racks - Required Supplies

D1200894

S1105251

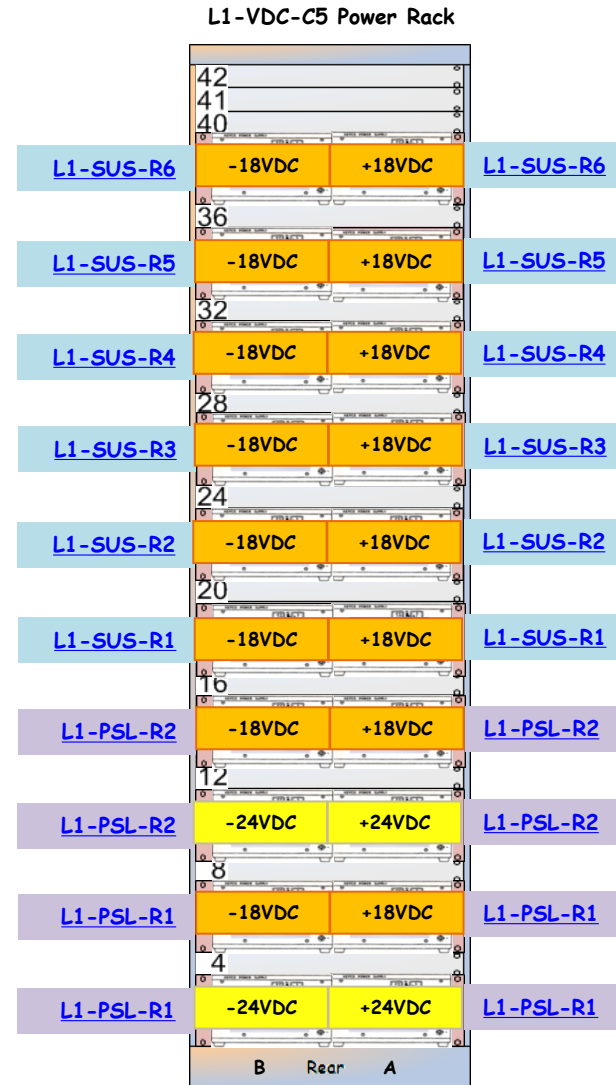
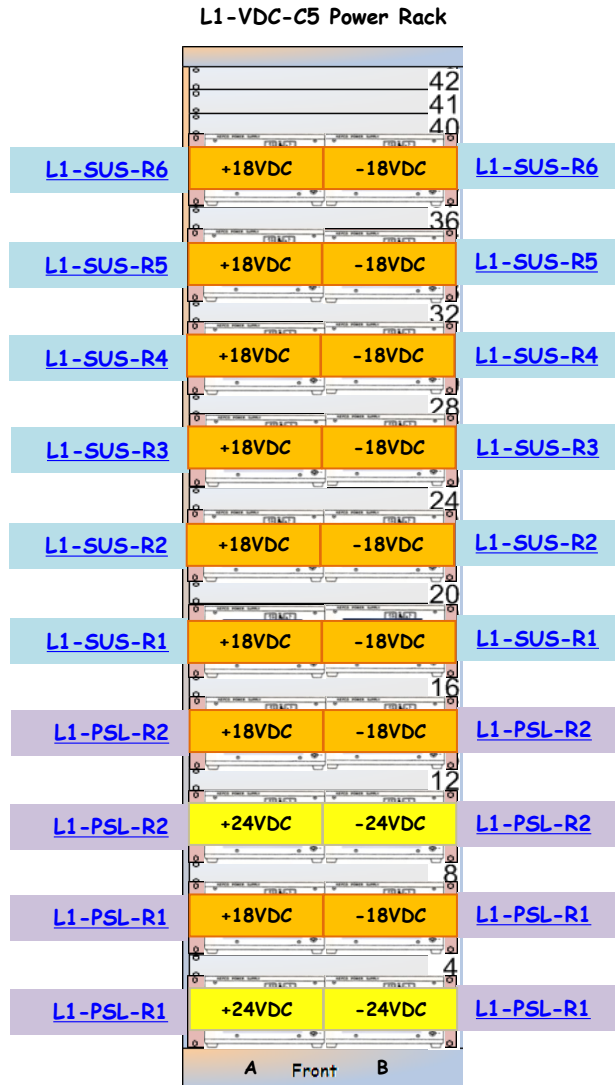

[Cable Runs >>](#)

L1-VDC-C6 Power Racks - Required Supplies

D1200895
S1105252

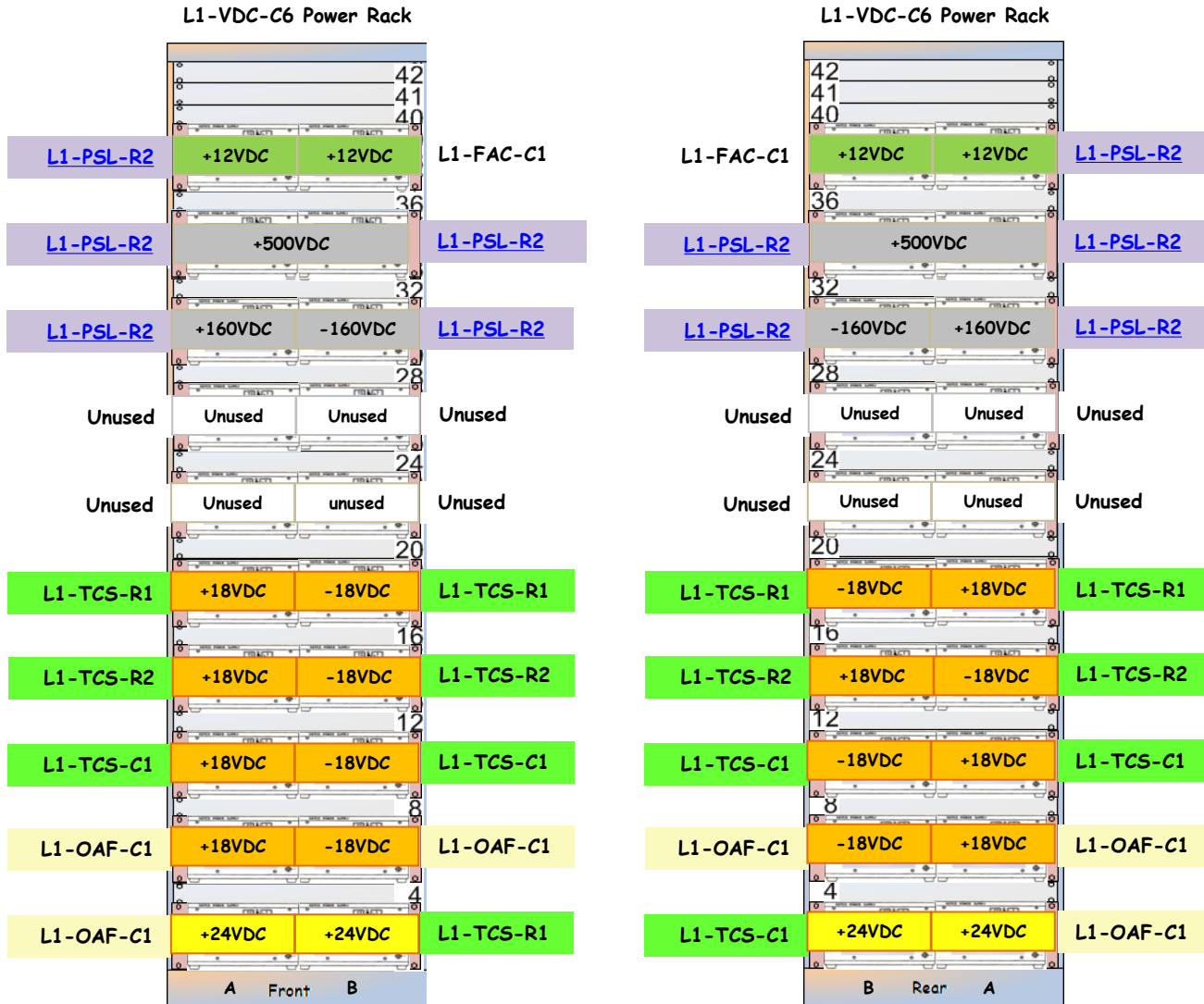

L1-VDC-C7 Power Racks - Required Supplies

D1200896
S1105253

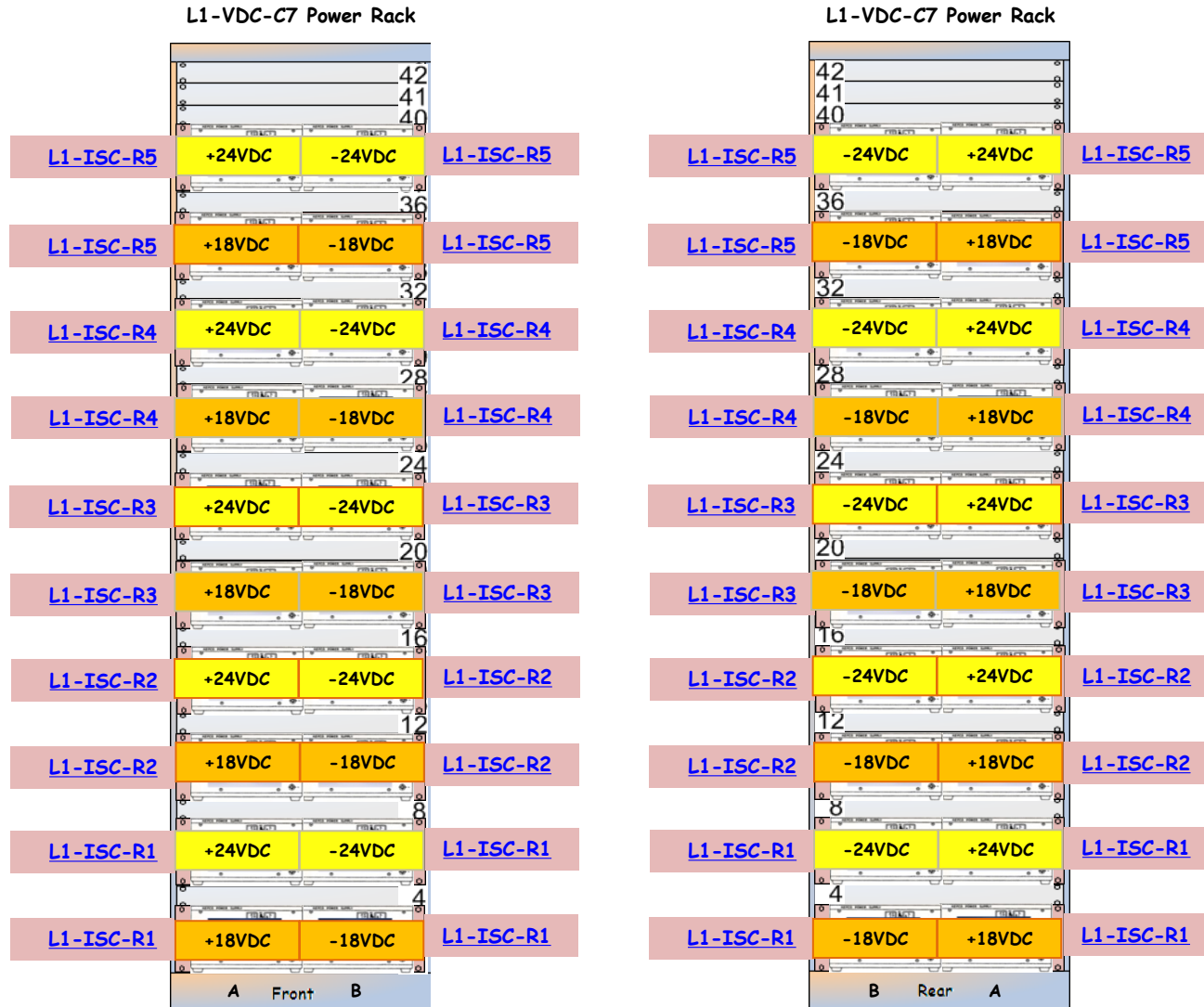

[Cable Runs >>](#)

L1-VDC-C1 Cable Runs

<< [L1-VDC-C1](#)

[D1200890](#)

[S1105247](#)

| L1-VDC-C1 S1105247 | Power Panel | Circuit | DC Power Rack | Outlet | Plug Position | Rack U | DC Power Supply | Polarity | DC Extension Cable | Electronics Rack |
|---|-------------|---------|---------------|--------|---------------|---------------|-----------------|----------|--------------------|------------------|
| 1 | CDS-1 | 06 | L1-VDC-C1 | 08 | Top | U37-A (Left) | H236464 | Plus | PTO-001 | L1-SUS-C8 |
| 2 | CDS-1 | 06 | L1-VDC-C1 | 08 | Bottom | U37-B (Right) | H236467 | Minus | PTO-001 | L1-SUS-C8 |
| 3 | CDS-1 | 27 | L1-VDC-C1 | 02 | Top | U33-A (Left) | H236434 | Plus | PTO-002 | L1-SUS-C7 |
| 4 | CDS-1 | 27 | L1-VDC-C1 | 02 | Bottom | U33-B (Right) | H236427 | Minus | PTO-002 | L1-SUS-C7 |
| 5 | CDS-1 | 08 | L1-VDC-C1 | 09 | Top | U29-A (Left) | H236468 | Plus | PTO-021 | L1-SUS-C6A |
| 6 | CDS-1 | 08 | L1-VDC-C1 | 09 | Bottom | U29-B (Right) | H236372-R1 | Minus | PTO-021 | L1-SUS-C6A |
| 7 | CDS-1 | 29 | L1-VDC-C1 | 03 | Top | U25-A (Left) | H236447 | Plus | PTO-003 | L1-SUS-C6B |
| 8 | CDS-1 | 29 | L1-VDC-C1 | 03 | Bottom | U25-B (Right) | H236463 | Minus | PTO-003 | L1-SUS-C6B |
| 9 | CDS-1 | 10 | L1-VDC-C1 | 10 | Top | U21-A (Left) | H236388 | Plus | PTO-004 | L1-SUS-C5 |
| 10 | CDS-1 | 10 | L1-VDC-C1 | 10 | Bottom | U21-B (Right) | H236406 | Minus | PTO-004 | L1-SUS-C5 |
| 11 | CDS-1 | 31 | L1-VDC-C1 | 04 | Top | U17-A (Left) | H236477 | Plus | PTO-005 | L1-SUS-C4A |
| 12 | CDS-1 | 31 | L1-VDC-C1 | 04 | Bottom | U17-B (Right) | H236404 | Minus | PTO-005 | L1-SUS-C4A |
| 13 | CDS-1 | 12 | L1-VDC-C1 | 11 | Top | U13-A (Left) | H236418 | Plus | PTO-022 | L1-SUS-C4B |
| 14 | CDS-1 | 12 | L1-VDC-C1 | 11 | Bottom | U13-B (Right) | H236424 | Minus | PTO-022 | L1-SUS-C4B |
| 15 | CDS-1 | 33 | L1-VDC-C1 | 05 | Top | U09-A (Left) | H236469 | Plus | PTO-006 | L1-SUS-C3 |
| 16 | CDS-1 | 33 | L1-VDC-C1 | 05 | Bottom | U09-B (Right) | H236443 | Minus | PTO-006 | L1-SUS-C3 |
| 17 | CDS-1 | 14 | L1-VDC-C1 | 12 | Top | U05-A (Left) | H210616 | Plus | PTO-007 | L1-SUS-C2 |
| 18 | CDS-1 | 14 | L1-VDC-C1 | 12 | Bottom | U05-B (Right) | H210622 | Minus | PTO-007 | L1-SUS-C2 |
| 19 | CDS-1 | 02 | L1-VDC-C1 | 06 | Top | U01-A (Left) | H210617 | Plus | PTO-008 | L1-SUS-C1 |
| 20 | CDS-1 | 02 | L1-VDC-C1 | 06 | Bottom | U01-B (Right) | H210619 | Minus | PTO-008 | L1-SUS-C1 |
| D1200890 | | | | | | | | | | |

L1-VDC-C2 Cable Runs

<< L1-VDC-C2

[D1200891](#)
[S1105248](#)

| L1-VDC-C2 S1105248 | Power Panel | Circuit | DC Power Rack | Outlet | Plug Position | Rack U | DC Power Supply | Polarity | DC Extension Cable | Electronics Rack |
|---|-------------|---------|---------------|--------|---------------|---------------|-----------------|----------|--------------------|------------------|
| 1 | CDS-1 | 15 | L1-VDC-C2 | 08 | Top | U37-A (Left) | H236460 | Plus | PTG-002 | L1-ISC-C3 |
| 2 | CDS-1 | 15 | L1-VDC-C2 | 08 | Bottom | U37-B (Right) | H236433 | Plus | PTG-003 | L1-ISC-C4 |
| 3 | CDS-1 | 03 | L1-VDC-C2 | 02 | Top | U33-A (Left) | H236426 | Plus | PTY-012 | L1-ISC-C4 |
| 4 | CDS-1 | 03 | L1-VDC-C2 | 02 | Bottom | U33-B (Right) | H236439 | Minus | PTY-012 | L1-ISC-C4 |
| 5 | CDS-1 | 17 | L1-VDC-C2 | 09 | Top | U29-A (Left) | H236428 | Plus | PTO-057 | L1-ISC-C4 |
| 6 | CDS-1 | 17 | L1-VDC-C2 | 09 | Bottom | U29-B (Right) | H236425 | Minus | PTO-057 | L1-ISC-C4 |
| 7 | CDS-1 | 05 | L1-VDC-C2 | 03 | Top | U25-A (Left) | H236444 | Plus | PTY-011 | L1-ISC-C3 |
| 8 | CDS-1 | 05 | L1-VDC-C2 | 03 | Bottom | U25-B (Right) | H236471 | Minus | PTY-011 | L1-ISC-C3 |
| 9 | CDS-1 | 19 | L1-VDC-C2 | 10 | Top | U21-A (Left) | H236408 | Plus | PTO-056 | L1-ISC-C3 |
| 10 | CDS-1 | 19 | L1-VDC-C2 | 10 | Bottom | U21-B (Right) | H236466 | Minus | PTO-056 | L1-ISC-C3 |
| 11 | CDS-1 | 07 | L1-VDC-C2 | 04 | Top | U17-A (Left) | H236430 | Plus | PTY-047 | L1-ISC-C2 |
| 12 | CDS-1 | 07 | L1-VDC-C2 | 04 | Bottom | U17-B (Right) | H236445 | Minus | PTY-047 | L1-ISC-C2 |
| 13 | CDS-1 | 21 | L1-VDC-C2 | 11 | Top | U13-A (Left) | H236431 | Plus | PTO-055 | L1-ISC-C2 |
| 14 | CDS-1 | 21 | L1-VDC-C2 | 11 | Bottom | U13-B (Right) | H236470 | Minus | PTO-055 | L1-ISC-C2 |
| 15 | CDS-1 | 09 | L1-VDC-C2 | 05 | Top | U09-A (Left) | H236405 | Plus | PTY-046 | L1-ISC-C1 |
| 16 | CDS-1 | 09 | L1-VDC-C2 | 05 | Bottom | U09-B (Right) | H236411 | Minus | PTY-046 | L1-ISC-C1 |
| 17 | CDS-1 | 23 | L1-VDC-C2 | 12 | Top | U05-A (Left) | H236475 | Plus | PTO-054 | L1-ISC-C1 |
| 18 | CDS-1 | 23 | L1-VDC-C2 | 12 | Bottom | U05-B (Right) | H236455 | Minus | PTO-054 | L1-ISC-C1 |
| 19 | CDS-1 | 06 | L1-VDC-C2 | 06 | Top | U01-A (Left) | H236399 | Plus | L1-TB02 | L1-ISC-C1 |
| 20 | CDS-1 | 06 | L1-VDC-C2 | 06 | Bottom | U01-B (Right) | H236407 | Plus | L1-TB07 | L1-ISC-C2 |
| D1200891 | | | | | | | | | | |

L1-VDC-C3 Cable Runs

<< L1-VDC-C3

[D1200892](#)

[S1105249](#)

| L1-VDC-C3 S1105249 | Power Panel | Circuit | DC Power Rack | Outlet | Plug Position | Rack U | DC Power Supply | Polarity | DC Extension Cable | Electronics Rack |
|---|-------------|---------|---------------|--------|---------------|---------------|-----------------|----------|--------------------|------------------|
| 1 | CDS-2 | 15 | L1-VDC-C3 | 08 | Top | U37-A (Left) | H236457 | Plus | PTO-014 | L1-SEI-C4 |
| 2 | CDS-2 | 15 | L1-VDC-C3 | 08 | Bottom | U37-B (Right) | H236456 | Minus | PTO-014 | L1-SEI-C4 |
| 3 | CDS-2 | 03 | L1-VDC-C3 | 02 | Top | U33-A (Left) | H236450 | Plus | PTY-013 | L1-SEI-C4 |
| 4 | CDS-2 | 03 | L1-VDC-C3 | 02 | Bottom | U33-B (Right) | H236454 | Minus | PTY-013 | L1-SEI-C4 |
| 5 | CDS-2 | 17 | L1-VDC-C3 | 09 | Top | U29-A (Left) | H236452 | Plus | PTO-015 | L1-SEI-C3 |
| 6 | CDS-2 | 17 | L1-VDC-C3 | 09 | Bottom | U29-B (Right) | H236451 | Minus | PTO-015 | L1-SEI-C3 |
| 7 | CDS-2 | 05 | L1-VDC-C3 | 03 | Top | U25-A (Left) | H236458 | Plus | PTY-014 | L1-SEI-C3 |
| 8 | CDS-2 | 05 | L1-VDC-C3 | 03 | Bottom | U25-B (Right) | H236432 | Minus | PTY-014 | L1-SEI-C3 |
| 9 | CDS-2 | 19 | L1-VDC-C3 | 10 | Top | U21-A (Left) | H236435 | Plus | PTY-015 | L1-SEI-C3 |
| 10 | CDS-2 | 19 | L1-VDC-C3 | 10 | Bottom | U21-B (Right) | H236436 | Plus | PTY-016 | L1-SEI-C4 |
| 11 | CDS-2 | 07 | L1-VDC-C3 | 04 | Top | U17-A (Left) | H236402 | Plus | PTO-016 | L1-SEI-C2 |
| 12 | CDS-2 | 07 | L1-VDC-C3 | 04 | Bottom | U17-B (Right) | H236395 | Minus | PTO-016 | L1-SEI-C2 |
| 13 | CDS-2 | 21 | L1-VDC-C3 | 11 | Top | U13-A (Left) | H236384 | Plus | PTY-017 | L1-SEI-C2 |
| 14 | CDS-2 | 21 | L1-VDC-C3 | 11 | Bottom | U13-B (Right) | H236390 | Minus | PTY-017 | L1-SEI-C2 |
| 15 | CDS-2 | 09 | L1-VDC-C3 | 05 | Top | U09-A (Left) | H236383 | Plus | PTO-017 | L1-SEI-C1 |
| 16 | CDS-2 | 09 | L1-VDC-C3 | 05 | Bottom | U09-B (Right) | H236391 | Minus | PTO-017 | L1-SEI-C1 |
| 17 | CDS-2 | 23 | L1-VDC-C3 | 12 | Top | U05-A (Left) | H236372-R2 | Plus | PTY-018 | L1-SEI-C1 |
| 18 | CDS-2 | 23 | L1-VDC-C3 | 12 | Bottom | U05-B (Right) | H236377 | Minus | PTY-018 | L1-SEI-C1 |
| 19 | CDS-2 | 11 | L1-VDC-C3 | 06 | Top | U01-A (Left) | H236401 | Plus | PTY-019 | L1-SEI-C1 |
| 20 | CDS-2 | 11 | L1-VDC-C3 | 06 | Bottom | U01-B (Right) | H236392 | Plus | PTY-020 | L1-SEI-C2 |
| D1200892 | | | | | | | | | | |

L1-VDC-C4 Cable Runs

<< [L1-VDC-C4](#)

[D1200893](#)
[S1105250](#)

| L1-VDC-C4 S1105250 | Power Panel | Circuit | DC Power Rack | Outlet | Plug Position | Rack U | DC Power Supply | Polarity | DC Extension Cable | Electronics Rack |
|---|-------------|---------|---------------|--------|---------------|---------------|-----------------|----------|--------------------|------------------|
| 1 | CDS-2 | 26 | L1-VDC-C4 | 08 | Top | U37-A (Left) | H236442 | Plus | PTO-018 | L1-PSL-C1 |
| 2 | CDS-2 | 26 | L1-VDC-C4 | 08 | Bottom | U37-B (Right) | H236416 | Minus | PTO-018 | L1-PSL-C1 |
| 3 | CDS-2 | 14 | L1-VDC-C4 | 02 | Top | U33-A (Left) | H236449 | | | |
| 4 | CDS-2 | 14 | L1-VDC-C4 | 02 | Bottom | U33-B (Right) | H236453 | Plus | PTY-009 | L1-PSL-C1 |
| 5 | CDS-2 | 28 | L1-VDC-C4 | 09 | Top | U29-A (Left) | H236495 | Plus | PTY-002 | L1-SUS-C5A |
| 6 | CDS-2 | 28 | L1-VDC-C4 | 09 | Bottom | U29-B (Right) | H236375 | Plus | PTY-005 | L1-SUS-C3A |
| 7 | CDS-2 | 16 | L1-VDC-C4 | 03 | Top | U25-A (Left) | H210621 | Plus | L1-TB03 | L1-SUS-C2 |
| 8 | CDS-2 | 16 | L1-VDC-C4 | 03 | Bottom | U25-B (Right) | H210620 | Plus | L1-TB04 | L1-SUS-C3B |
| 9 | CDS-2 | 30 | L1-VDC-C4 | 10 | Top | U21-A (Left) | H236389 | Plus | L1-TB01 | L1-SUS-C5B |
| 10 | CDS-2 | 30 | L1-VDC-C4 | 10 | Bottom | U21-B (Right) | H236386 | Plus | PTY-001 | L1-SUS-C8 |
| 11 | CDS-2 | 18 | L1-VDC-C4 | 04 | Top | U17-A (Left) | H236374 | Plus | PTO-019 | L1-SEI-C6 |
| 12 | CDS-2 | 18 | L1-VDC-C4 | 04 | Bottom | U17-B (Right) | H236382 | Minus | PTO-019 | L1-SEI-C6 |
| 13 | CDS-2 | 32 | L1-VDC-C4 | 11 | Top | U13-A (Left) | H236373 | Plus | PTY-021 | L1-SEI-C6 |
| 14 | CDS-2 | 32 | L1-VDC-C4 | 11 | Bottom | U13-B (Right) | H236387 | Minus | PTY-021 | L1-SEI-C6 |
| 15 | CDS-2 | 20 | L1-VDC-C4 | 05 | Top | U09-A (Left) | H236376 | Plus | PTO-020 | L1-SEI-C5 |
| 16 | CDS-2 | 20 | L1-VDC-C4 | 05 | Bottom | U09-B (Right) | H236379 | Minus | PTO-020 | L1-SEI-C5 |
| 17 | CDS-2 | 34 | L1-VDC-C4 | 12 | Top | U05-A (Left) | H236381 | Plus | PTY-022 | L1-SEI-C5 |
| 18 | CDS-2 | 34 | L1-VDC-C4 | 12 | Bottom | U05-B (Right) | H236385 | Minus | PTY-022 | L1-SEI-C5 |
| 19 | CDS-2 | 22 | L1-VDC-C4 | 06 | Top | U01-A (Left) | H236415 | Plus | PTY-023 | L1-SEI-C5 |
| 20 | CDS-2 | 22 | L1-VDC-C4 | 06 | Bottom | U01-B (Right) | H236403 | Plus | PTY-024 | L1-SEI-C6 |
| D1200893 | | | | | | | | | | |

L1-VDC-C5 Cable Runs

<< [L1-VDC-C5](#)

[D1200894](#)

[S1105251](#)

| L1-VDC-C5 S1105251 | Power Panel | Circuit | DC Power Rack | Outlet | Plug Position | Rack U | DC Power Supply | Polarity | DC Extension Cable | Electronics Rack |
|---|-------------|---------|---------------|--------|---------------|---------------|-----------------|----------|--------------------|------------------|
| 1 | CDS-1 | 25 | L1-VDC-C5 | 08 | Top | U37-A (Left) | H236419 | Plus | PTO-027 | L1-SUS-R6 |
| 2 | CDS-1 | 25 | L1-VDC-C5 | 08 | Bottom | U37-B (Right) | H236412 | Minus | PTO-027 | L1-SUS-R6 |
| 3 | CDS-2 | 13 | L1-VDC-C5 | 02 | Top | U33-A (Left) | H236417 | Plus | PTO-028 | L1-SUS-R5 |
| 4 | CDS-2 | 13 | L1-VDC-C5 | 02 | Bottom | U33-B (Right) | H236421 | Minus | PTO-028 | L1-SUS-R5 |
| 5 | CDS-1 | 13 | L1-VDC-C5 | 09 | Top | U29-A (Left) | H236423 | Plus | PTO-029 | L1-SUS-R4 |
| 6 | CDS-1 | 13 | L1-VDC-C5 | 09 | Bottom | U29-B (Right) | H236413 | Minus | PTO-029 | L1-SUS-R4 |
| 7 | CDS-2 | 38 | L1-VDC-C5 | 03 | Top | U25-A (Left) | H236414 | Plus | PTO-030 | L1-SUS-R3 |
| 8 | CDS-2 | 38 | L1-VDC-C5 | 03 | Bottom | U25-B (Right) | H236422 | Minus | PTO-030 | L1-SUS-R3 |
| 9 | CDS-1 | 01 | L1-VDC-C5 | 10 | Top | U21-A (Left) | H236420 | Plus | PTO-023 | L1-SUS-R2 |
| 10 | CDS-1 | 01 | L1-VDC-C5 | 10 | Bottom | U21-B (Right) | H236378 | Minus | PTO-023 | L1-SUS-R2 |
| 11 | CDS-2 | 12 | L1-VDC-C5 | 04 | Top | U17-A (Left) | H236409 | Plus | PTO-024 | L1-SUS-R1 |
| 12 | CDS-2 | 12 | L1-VDC-C5 | 04 | Bottom | U17-B (Right) | H236410 | Minus | PTO-024 | L1-SUS-R1 |
| 13 | CDS-1 | 04 | L1-VDC-C5 | 11 | Top | U13-A (Left) | H236380 | Plus | PTO-025 | L1-PSL-R2 |
| 14 | CDS-1 | 04 | L1-VDC-C5 | 11 | Bottom | U13-B (Right) | H236465 | Minus | PTO-025 | L1-PSL-R2 |
| 15 | CDS-2 | 24 | L1-VDC-C5 | 05 | Top | U09-A (Left) | H236459 | Plus | PTY-025 | L1-PSL-R2 |
| 16 | CDS-2 | 24 | L1-VDC-C5 | 05 | Bottom | U09-B (Right) | H236394 | Minus | PTY-025 | L1-PSL-R2 |
| 17 | CDS-2 | 01 | L1-VDC-C5 | 12 | Top | U05-A (Left) | H236397 | Plus | PTO-026 | L1-PSL-R1 |
| 18 | CDS-2 | 01 | L1-VDC-C5 | 12 | Bottom | U05-B (Right) | H236400 | Minus | PTO-026 | L1-PSL-R1 |
| 19 | CDS-2 | 36 | L1-VDC-C5 | 06 | Top | U01-A (Left) | H236393 | Plus | L1-TB05 | L1-PSL-R1 |
| 20 | CDS-2 | 36 | L1-VDC-C5 | 06 | Bottom | U01-B (Right) | H236398 | Minus | L1-TB05 | L1-PSL-R1 |
| D1200894 | | | | | | | | | | |

L1-VDC-C6 Cable Runs

<< L1-VDC-C6

[D1200895](#)

[S1105252](#)

| L1-VDC-C6 S1105252 | Power Panel | Circuit | DC Power Rack | Outlet | Plug Position | Rack U | DC Power Supply | Polarity | DC Extension Cable | Electronics Rack |
|---|-------------|---------|---------------|--------|---------------|---------------|-----------------|----------|--------------------|------------------|
| 1 | CDS-2 | 37 | L1-VDC-C6 | 08 | Top | U37-A (Left) | | Plus | PTB-001 | L1-PSL-R2 |
| 2 | CDS-2 | 37 | L1-VDC-C6 | 08 | Bottom | U37-B (Right) | | Plus | PTG-001 | L1-FAC-C1 |
| 3 | CDS-2 | 31 | L1-VDC-C6 | 02 | Top | U33-A (Left) | | Plus | PBX-001 | L1-PSL-R2 |
| 4 | CDS-2 | 31 | L1-VDC-C6 | 02 | Bottom | U33-B (Right) | | Plus | PBX-001 | L1-PSL-R2 |
| 5 | CDS-2 | 27 | L1-VDC-C6 | 09 | Top | U29-A (Left) | | Plus | PBX-002 | L1-PSL-R2 |
| 6 | CDS-2 | 27 | L1-VDC-C6 | 09 | Bottom | U29-B (Right) | | Minus | PBX-002 | L1-PSL-R2 |
| 7 | CDS-2 | 08 | L1-VDC-C6 | 03 | Top | U25-A (Left) | | | | |
| 8 | CDS-2 | 08 | L1-VDC-C6 | 03 | Bottom | U25-B (Right) | | | | |
| 9 | CDS-2 | 39 | L1-VDC-C6 | 10 | Top | U21-A (Left) | | | | |
| 10 | CDS-2 | 39 | L1-VDC-C6 | 10 | Bottom | U21-B (Right) | | | | |
| 11 | CDS-2 | 33 | L1-VDC-C6 | 04 | Top | U17-A (Left) | | Plus | PTO-038 | L1-TCS-R1 |
| 12 | CDS-2 | 33 | L1-VDC-C6 | 04 | Bottom | U17-B (Right) | | Minus | PTO-038 | L1-TCS-R1 |
| 13 | CDS-2 | 29 | L1-VDC-C6 | 11 | Top | U13-A (Left) | | Plus | PTO-037 | L1-TCS-R2 |
| 14 | CDS-2 | 29 | L1-VDC-C6 | 11 | Bottom | U13-B (Right) | | Minus | PTO-037 | L1-TCS-R2 |
| 15 | CDS-2 | 10 | L1-VDC-C6 | 05 | Top | U09-A (Left) | | Plus | PTO-013 | L1-TSC-C1 |
| 16 | CDS-2 | 10 | L1-VDC-C6 | 05 | Bottom | U09-B (Right) | | Minus | PTO-013 | L1-TSC-C1 |
| 17 | CDS-2 | 41 | L1-VDC-C6 | 12 | Top | U05-A (Left) | | Plus | PTO-012 | L1-OAF-C1 |
| 18 | CDS-2 | 41 | L1-VDC-C6 | 12 | Bottom | U05-B (Right) | | Minus | PTO-012 | L1-OAF-C1 |
| 19 | CDS-2 | 35 | L1-VDC-C6 | 06 | Top | U01-A (Left) | | Plus | PTY-053 | L1-OAF-C1 |
| 20 | CDS-2 | 35 | L1-VDC-C6 | 06 | Bottom | U01-B (Right) | | Plus | PTY-055 | L1-TSC-C1 |
| D1200895 | | | | | | | | | | |

L1-VDC-C7 Cable Runs

<< L1-VDC-C7

[D1200896](#)

[S1105253](#)

| L1-VDC-C7 S1105253 | Power Panel | Circuit | DC Power Rack | Outlet | Plug Position | Rack U | DC Power Supply | Polarity | DC Extension Cable | Electronics Rack |
|---|-------------|---------|---------------|--------|---------------|---------------|-----------------|----------|--------------------|------------------|
| 1 | CDS-1 | 22 | L1-VDC-C5 | 07 | Top | U37-A (Left) | | Plus | PTY-051 | L1-ISC-R5 |
| 2 | CDS-1 | 22 | L1-VDC-C5 | 07 | Bottom | U37-B (Right) | | Minus | PTY-051 | L1-ISC-R5 |
| 3 | CDS-1 | 16 | L1-VDC-C5 | 01 | Top | U33-A (Left) | | Plus | PTO-062 | L1-ISC-R5 |
| 4 | CDS-1 | 16 | L1-VDC-C5 | 01 | Bottom | U33-B (Right) | | Minus | PTO-062 | L1-ISC-R5 |
| 5 | CDS-1 | 34 | L1-VDC-C7 | 08 | Top | U29-A (Left) | | Plus | PTY-050 | L1-ISC-R4 |
| 6 | CDS-1 | 34 | L1-VDC-C7 | 08 | Bottom | U29-B (Right) | | Minus | PTY-050 | L1-ISC-R4 |
| 7 | CDS-1 | 28 | L1-VDC-C7 | 02 | Top | U25-A (Left) | | Plus | PTO-061 | L1-ISC-R4 |
| 8 | CDS-1 | 28 | L1-VDC-C7 | 02 | Bottom | U25-B (Right) | | Minus | PTO-061 | L1-ISC-R4 |
| 9 | CDS-1 | 24 | L1-VDC-C7 | 09 | Top | U21-A (Left) | | Plus | PTY-049 | L1-ISC-R3 |
| 10 | CDS-1 | 24 | L1-VDC-C7 | 09 | Bottom | U21-B (Right) | | Minus | PTY-049 | L1-ISC-R3 |
| 11 | CDS-1 | 18 | L1-VDC-C7 | 03 | Top | U17-A (Left) | | Plus | PTO-060 | L1-ISC-R3 |
| 12 | CDS-1 | 18 | L1-VDC-C7 | 03 | Bottom | U17-B (Right) | | Minus | PTO-060 | L1-ISC-R3 |
| 13 | CDS-2 | 02 | L1-VDC-C7 | 10 | Top | U13-A (Left) | | Plus | PTY-048 | L1-ISC-R2 |
| 14 | CDS-2 | 02 | L1-VDC-C7 | 10 | Bottom | U13-B (Right) | | Minus | PTY-048 | L1-ISC-R2 |
| 15 | CDS-1 | 30 | L1-VDC-C7 | 04 | Top | U09-A (Left) | | Plus | PTO-059 | L1-ISC-R2 |
| 16 | CDS-1 | 30 | L1-VDC-C7 | 04 | Bottom | U09-B (Right) | | Minus | PTO-059 | L1-ISC-R2 |
| 17 | CDS-1 | 26 | L1-VDC-C7 | 11 | Top | U05-A (Left) | | Plus | L1-TB06 | L1-ISC-R1 |
| 18 | CDS-1 | 26 | L1-VDC-C7 | 11 | Bottom | U05-B (Right) | | Minus | L1-TB06 | L1-ISC-R1 |
| 19 | CDS-1 | 20 | L1-VDC-C7 | 05 | Top | U01-A (Left) | | Plus | PTO-058 | L1-ISC-R1 |
| 20 | CDS-1 | 20 | L1-VDC-C7 | 05 | Bottom | U01-B (Right) | | Minus | PTO-058 | L1-ISC-R1 |
| D1200896 | | | | | | | | | | |

L1-TCS-C1

TCS Rack Layout ([LIGO-D1200258](#))

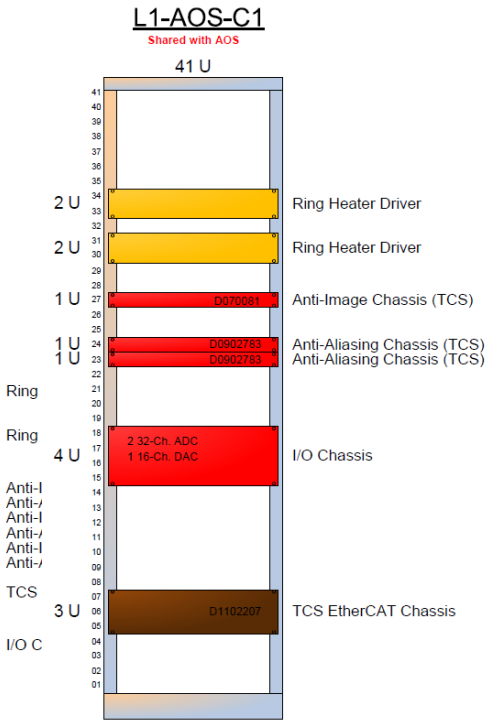
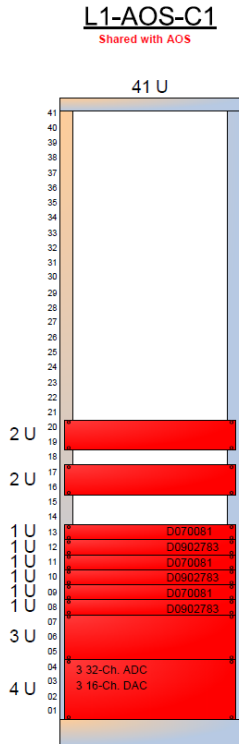

LIGO-D1200258-v3

l1tcs0 I/O Extension Chassis

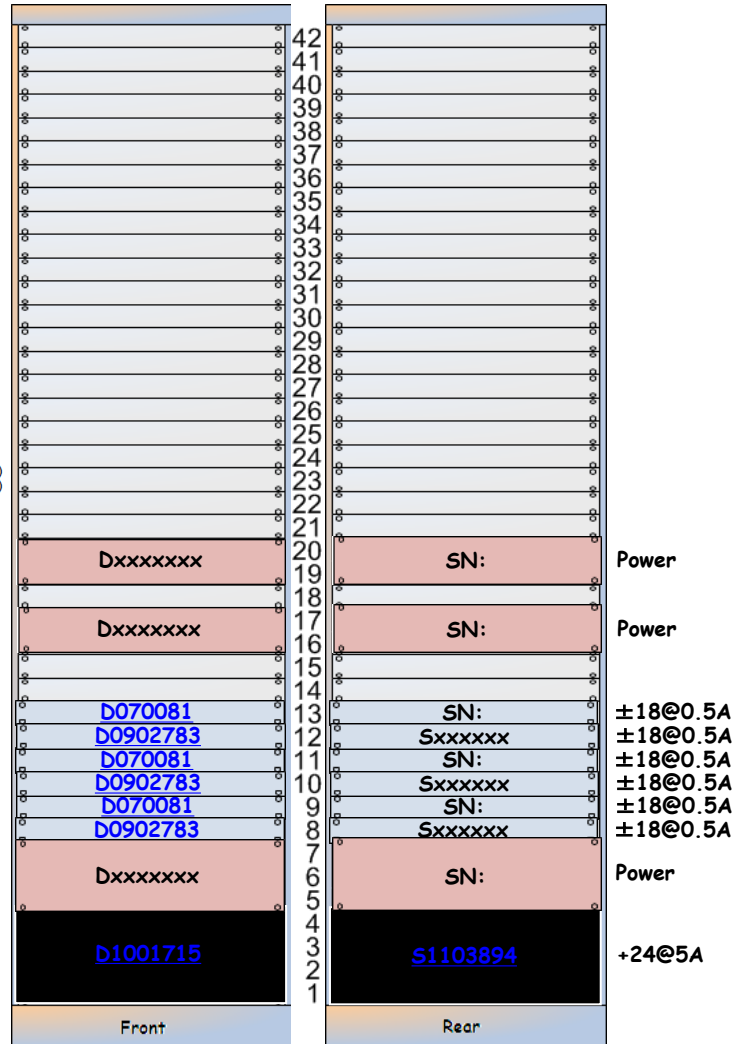

L1-TCS-C1 Details

[LIGO-D1200258](#)

[<< L1-TCS-C1](#)

Ring Heater Driver

Dxxxxxx

SN:

Power

[D0902783](#)

Front

Sxxxxx

Rear

[<< L1-TCS-C1](#)

Ring Heater Driver

Dxxxxxx

SN:

Power

[D0902783](#)

Front

Sxxxxx

Rear

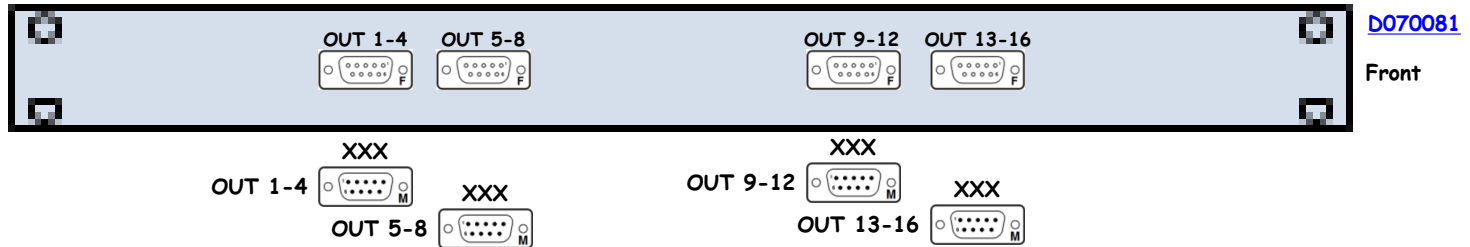

<< L1-TCS-1

Anti-Alias Chassis-CO2-X D0902783 Sxxxxxxx ±18@0.5A

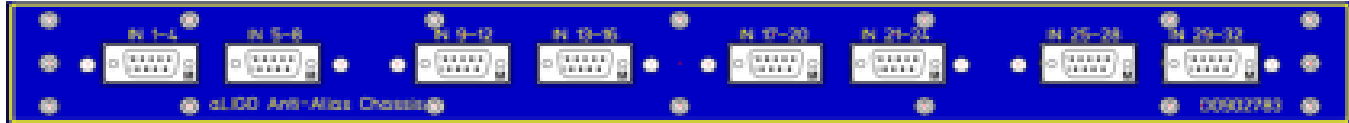

D0902783

Front

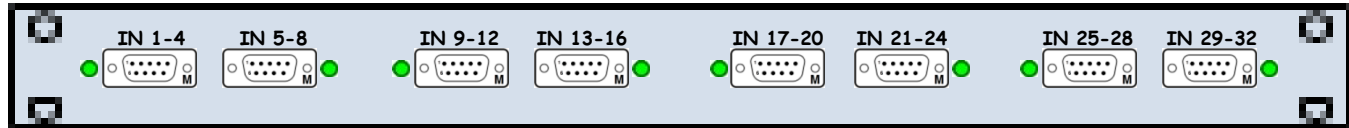

D070081

Front

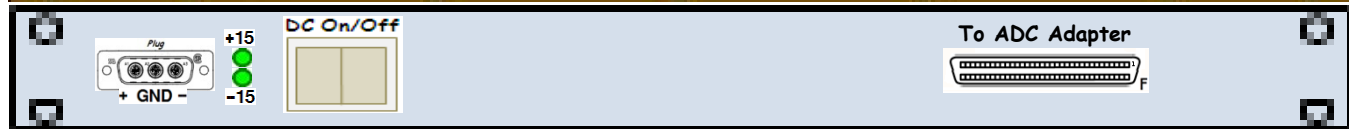
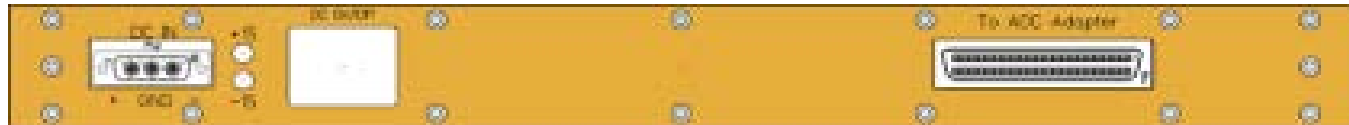
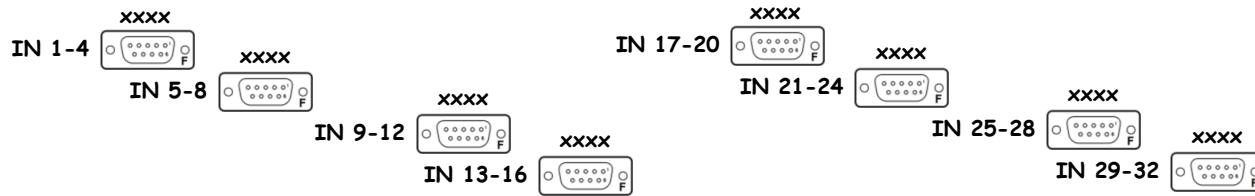

Sxxxxxxx

Rear



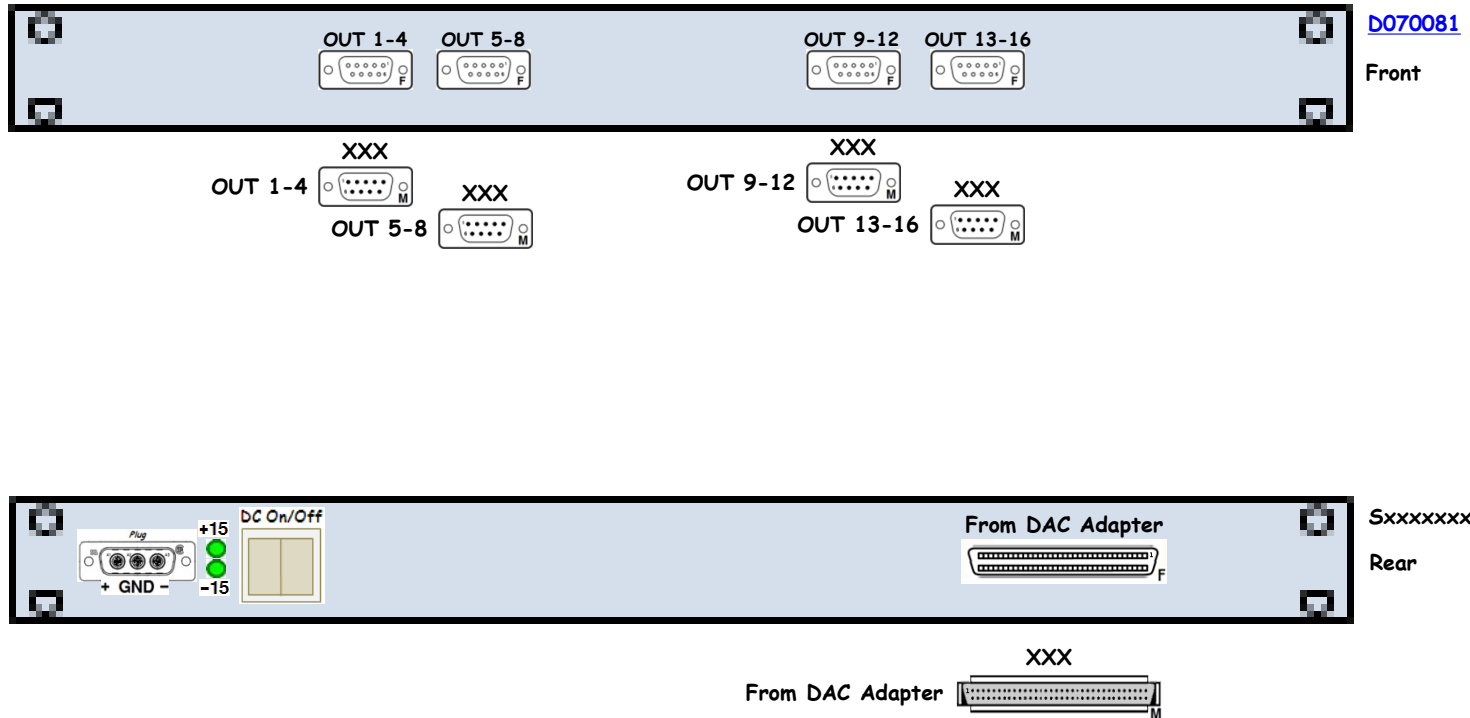

<< L1-TCS-1

Anti-Alias Chassis-CO2-Y D0902783 Sxxxxxxx ±18@0.5A

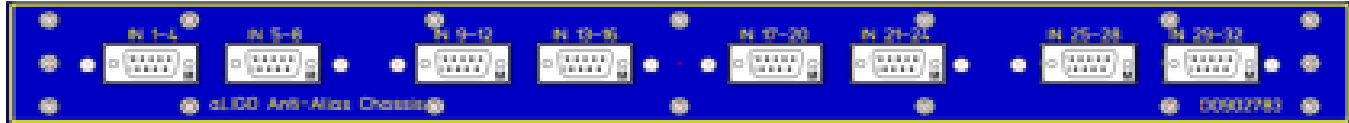

[D0902783](#)

Front

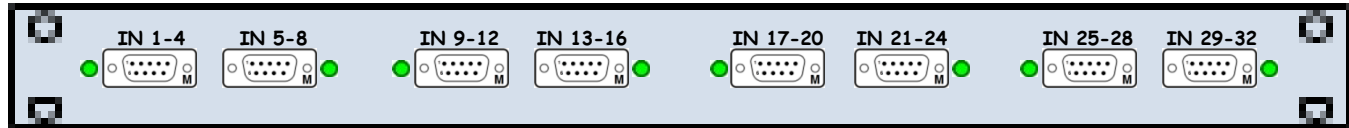

[D070081](#)

Front

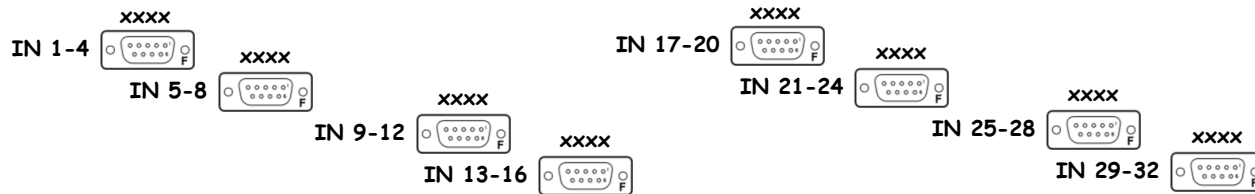

[Sxxxxxxx](#)

Rear

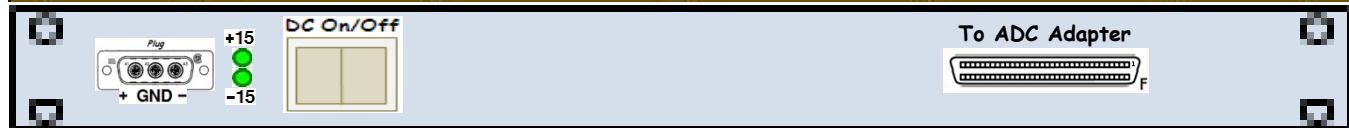

[TS-23](#)

To ADC Adapter

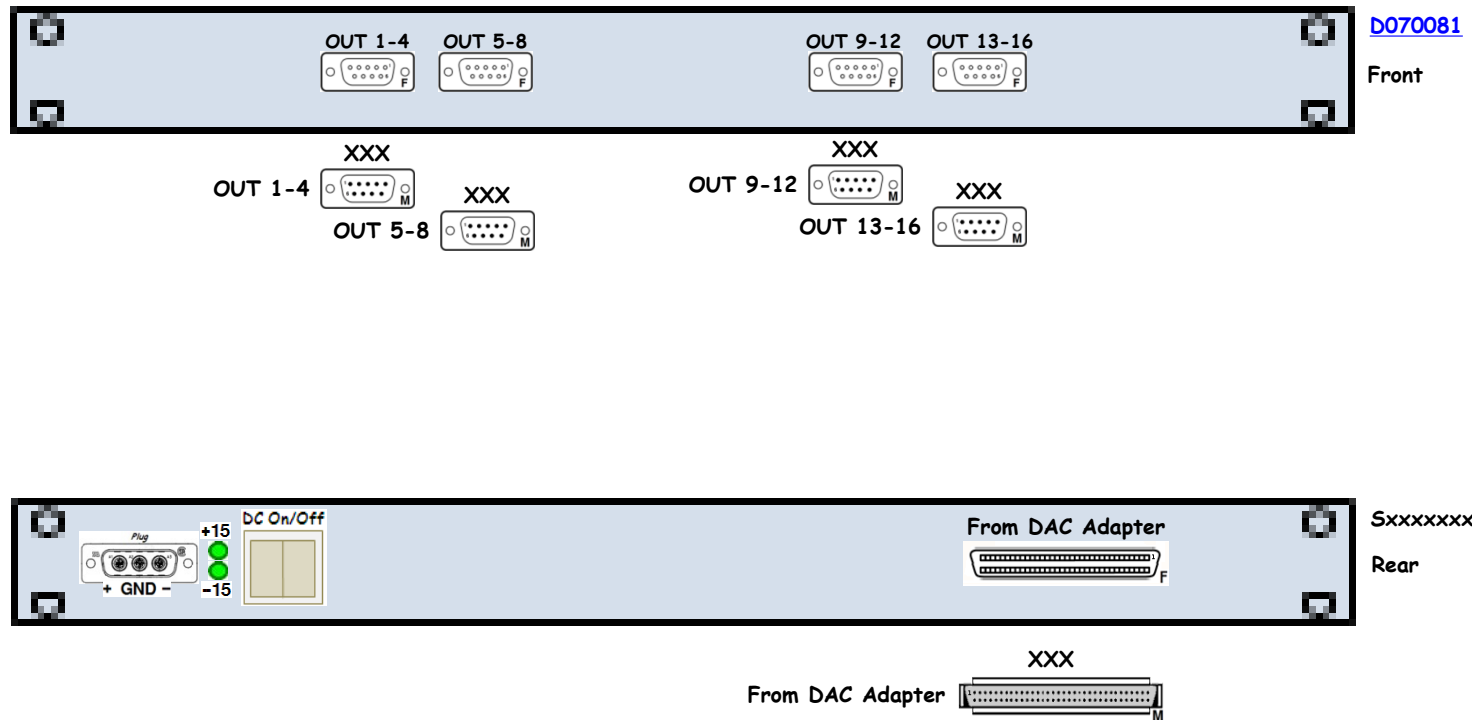

<< L1-TCS-1

Anti-Alias Chassis-RH D0902783 Sxxxxxxx ±18@0.5A

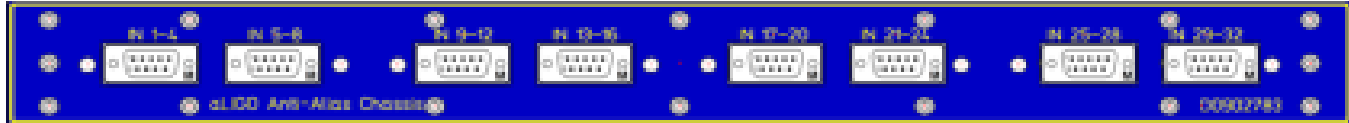

D0902783

Front

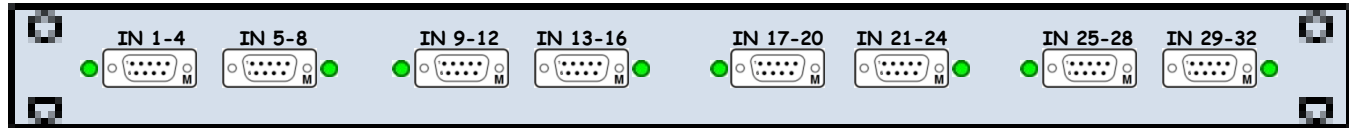

D070081

Front

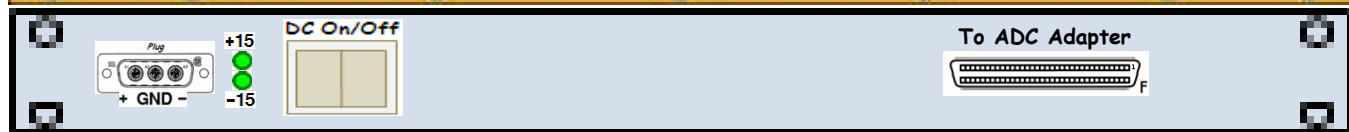
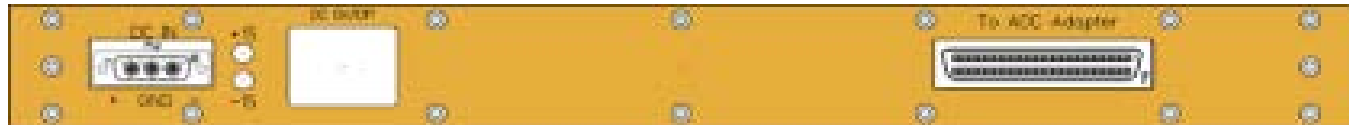
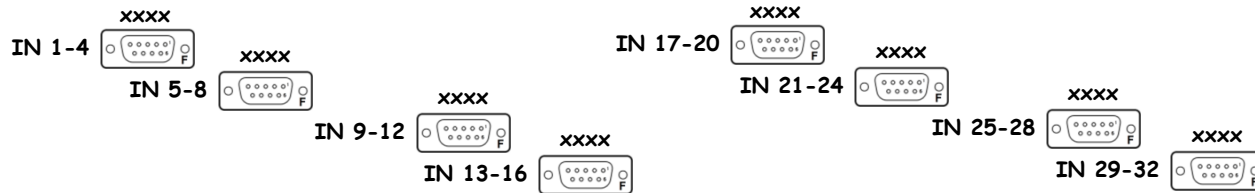

Sxxxxxxx

Rear



[<< L1-TCS-C1](#)

TCS Beckhoff Chassis

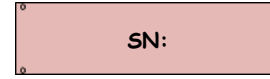

Power

[D0902783](#)

Front

Sxxxxxx

Rear



D1001715

Front

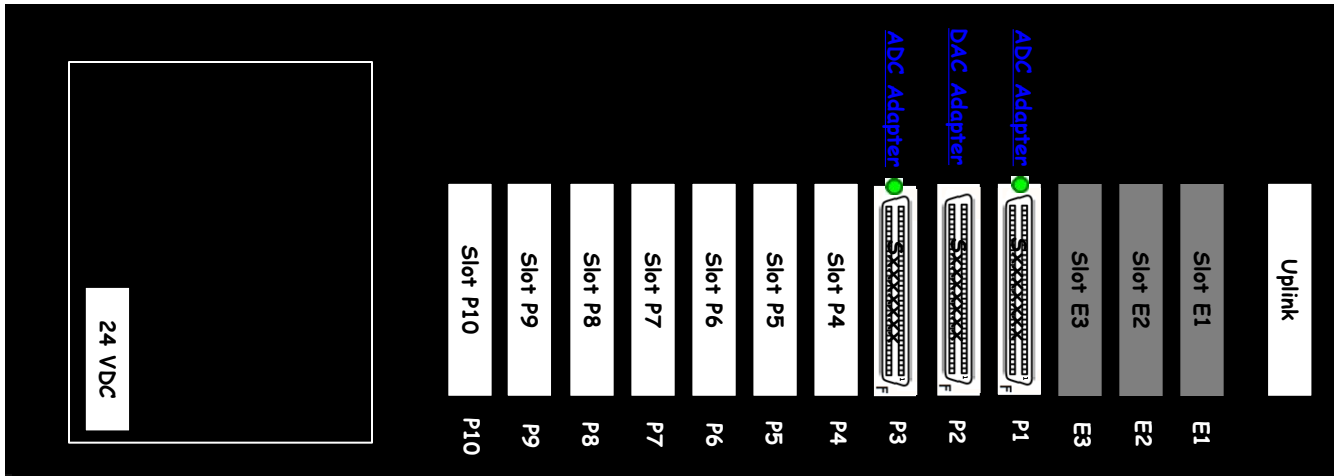

S1103894

Rear

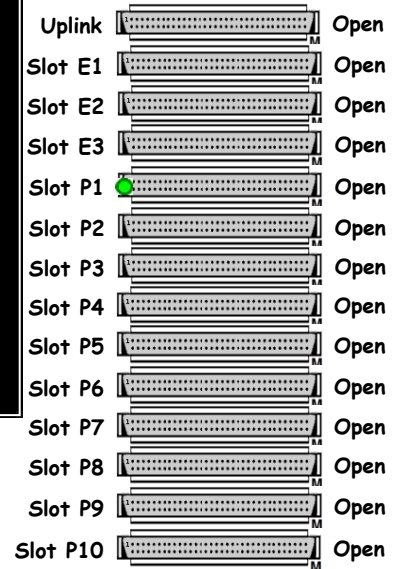

Subsystem: FAC (Facilities)

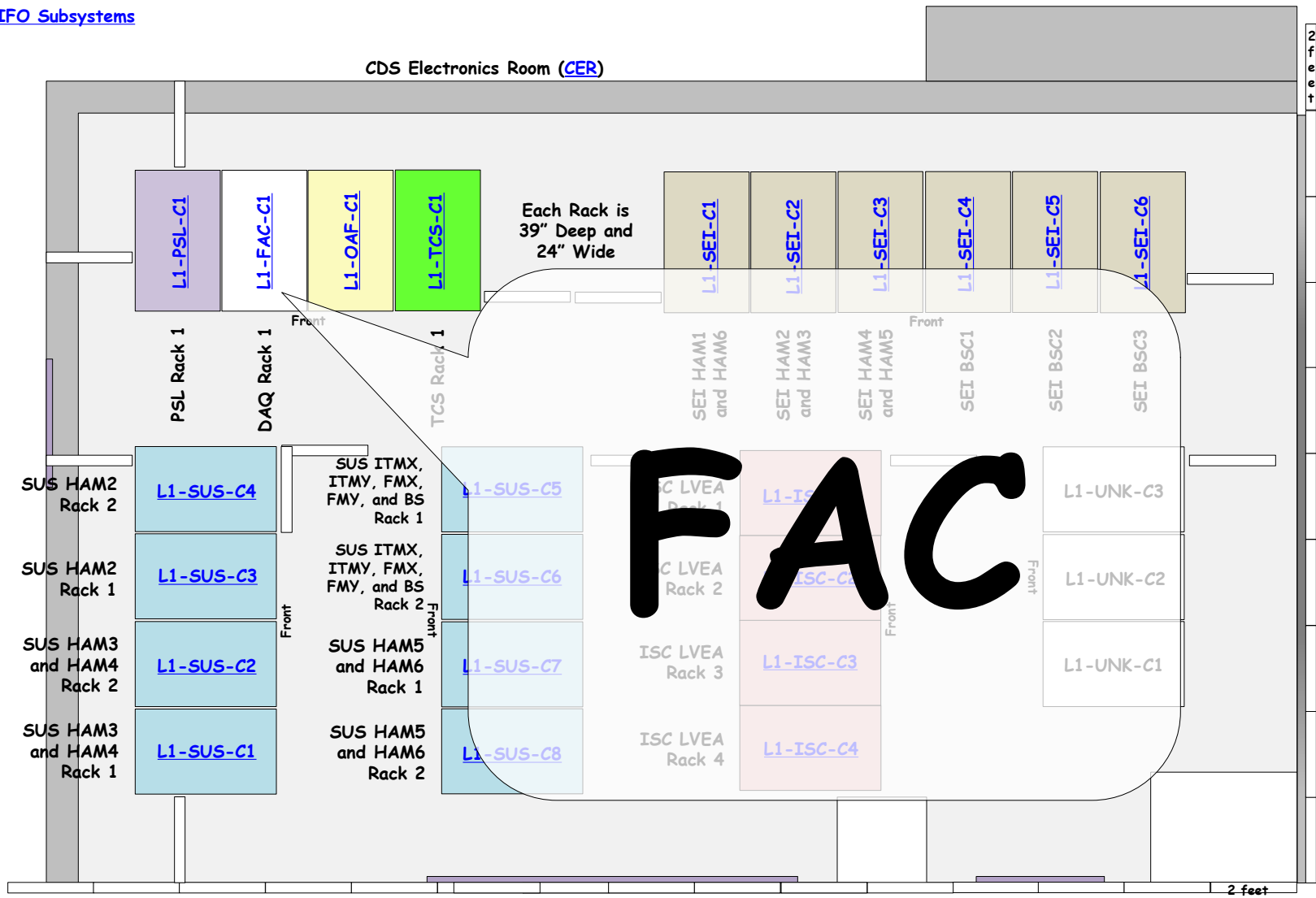

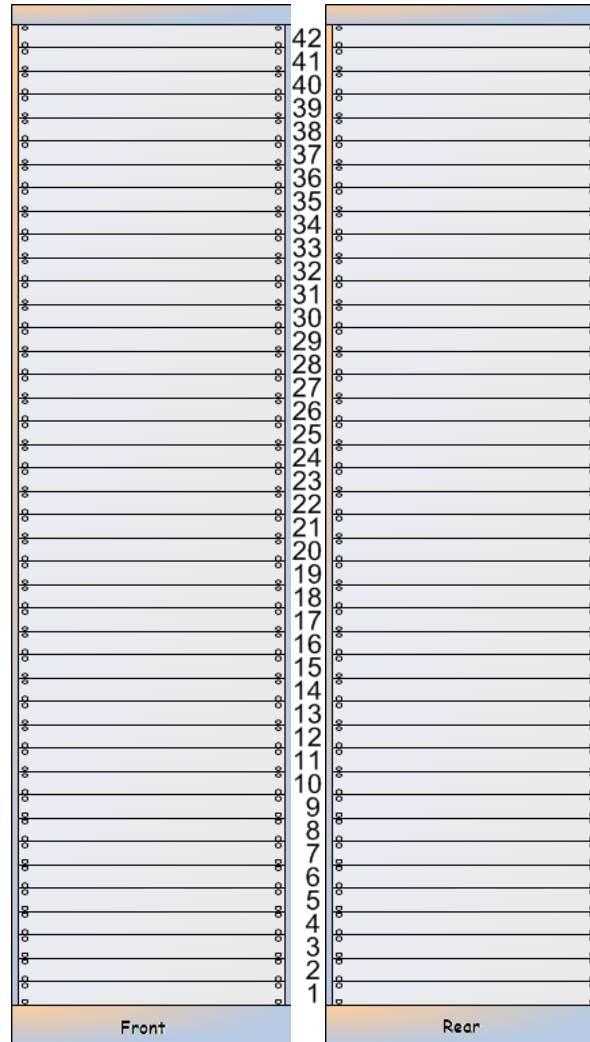

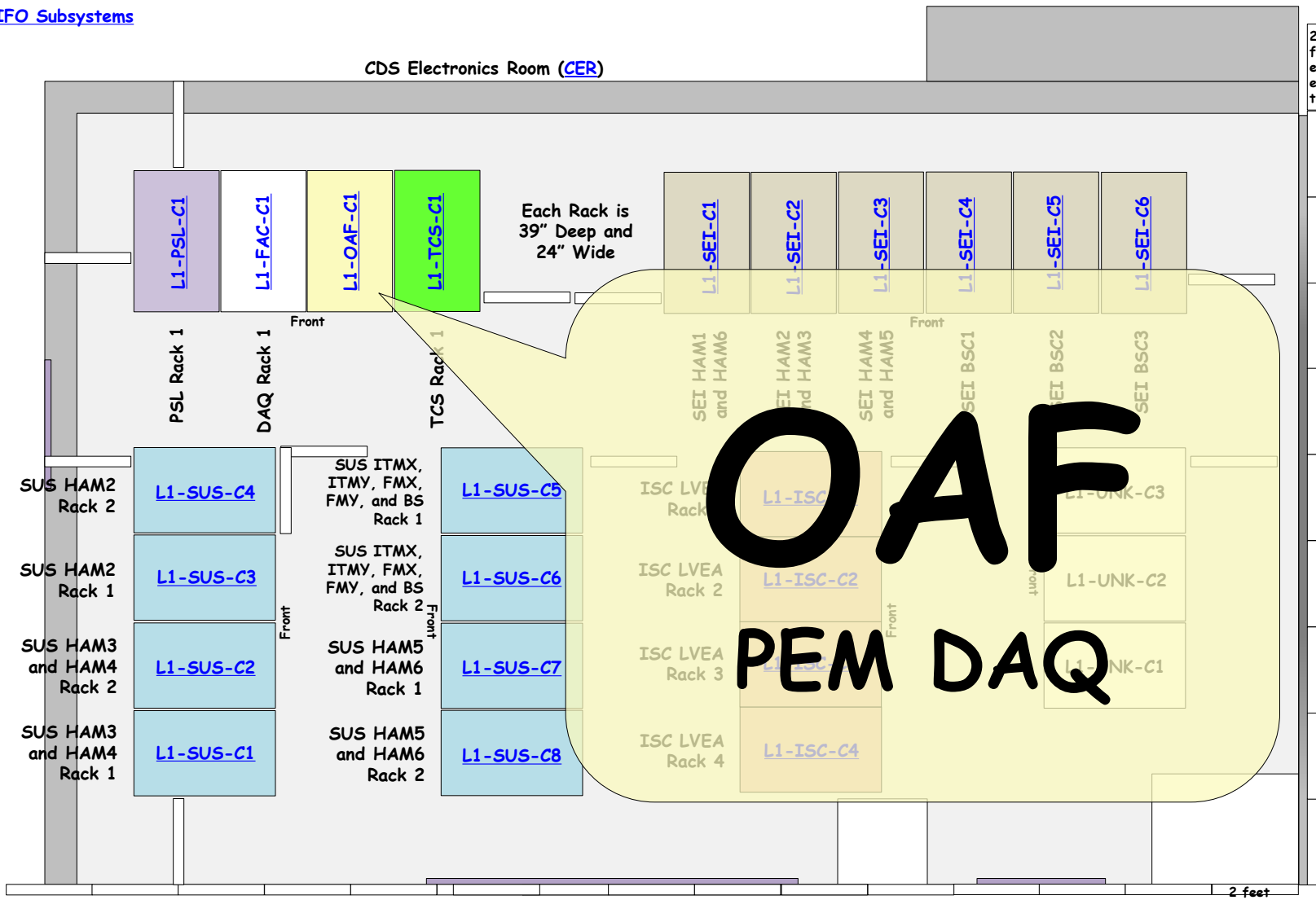

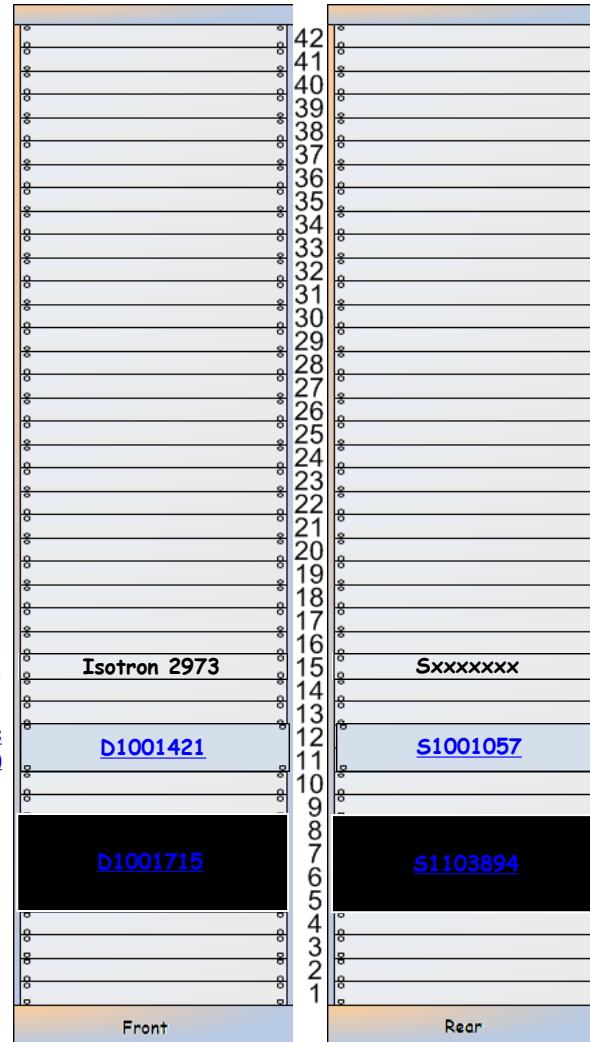

[Accelerometer Power Supply](#)

[aLIGO AA Interface Chassis
\(32 BNC x10 Gain Version\)](#)

[Iloaf0 I/O Extension Chassis](#)

| | |
|--------------|----|
| +12VDC | ?A |
| -12VDC | ?A |
| +18VDC | ?A |
| -18VDC | ?A |
| +24VDC | ?A |
| -24VDC | ?A |
| High Voltage | ?A |

L1-OAF-C1 Details

<< L1-OAF-C1

aLIGO AA Interface Chassis
(32 BNC, x10 Gain Version)

[D1001421](#)

[S1001057](#) :

Power

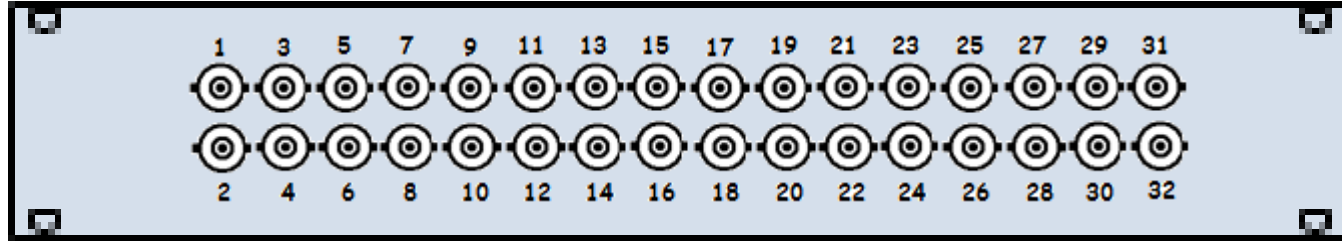

[D1001421](#)

Front

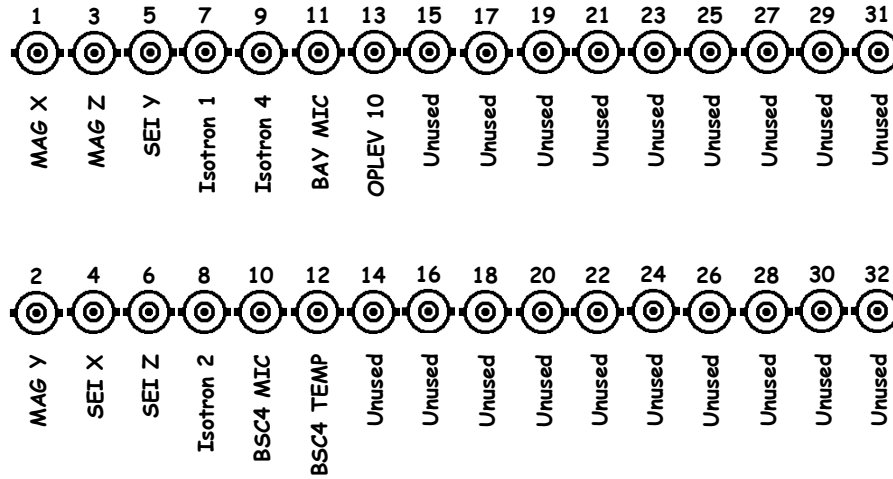

[S1001057](#)

Rear

[To I1oaf0 Slot P1](#)

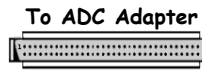

To ADC Adapter

11oaf0 I/O Extension Chassis

D1001715

S1103844

+24VDC



D1001715
Front

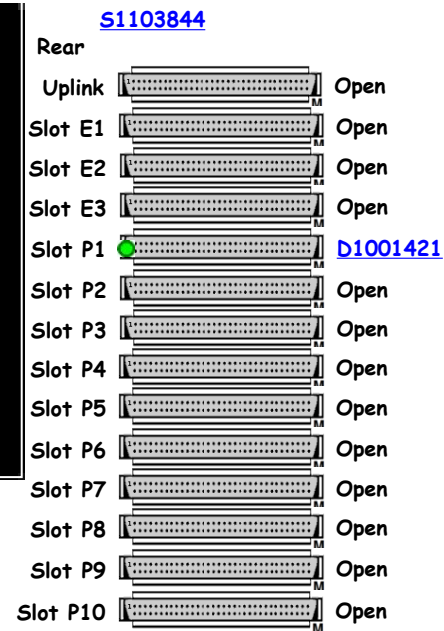
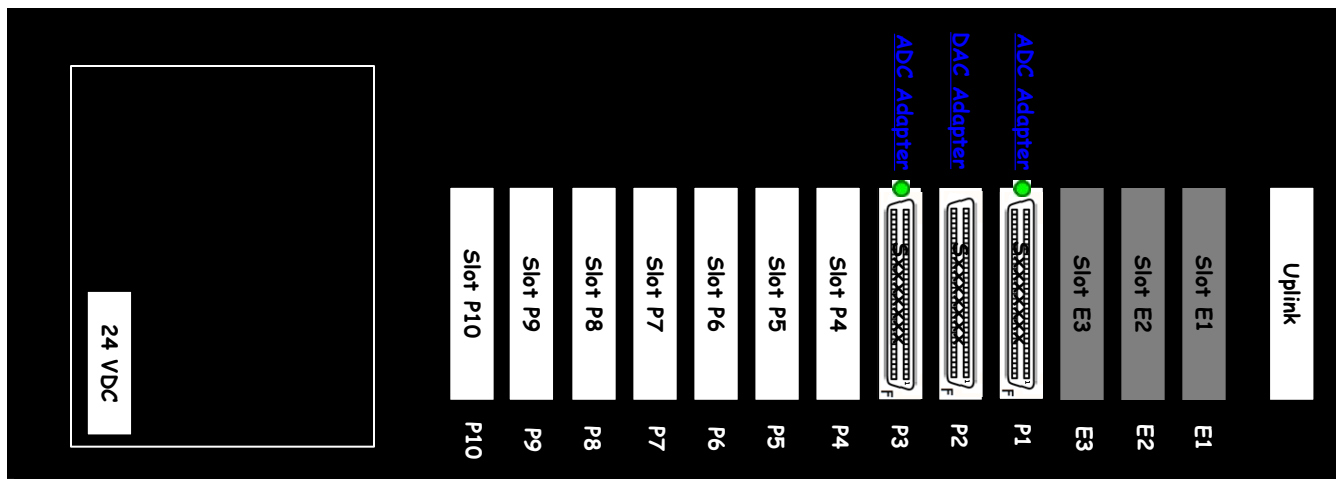

L1 PEM Sensor Details

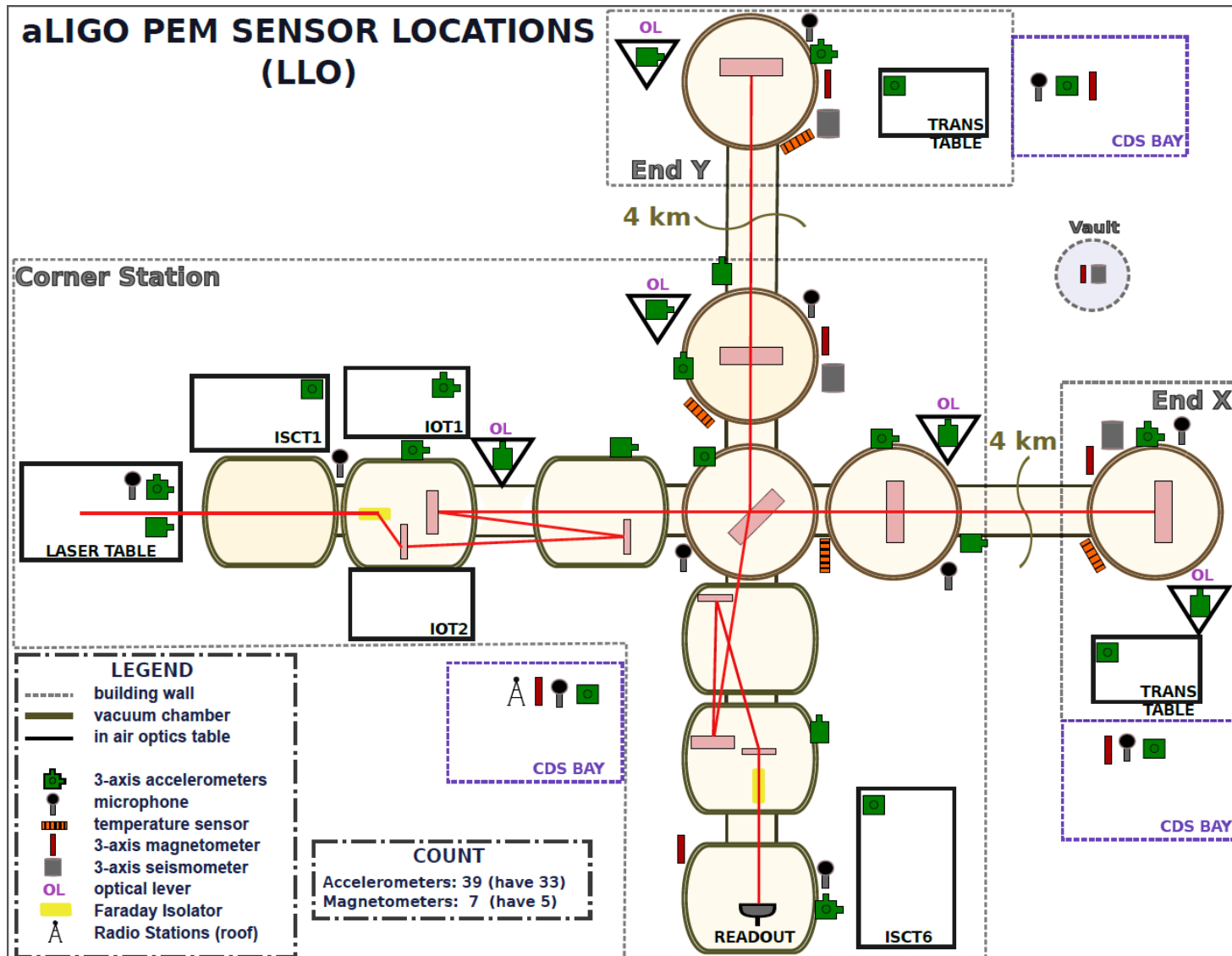

D1200615

- **Accelerometers**
 - $10^{-8} f^{-2} \text{ m Hz}^{-1/2}$
 - 10-200Hz (256Hz, 16bit)
- **Seismometers**
 - $3 \times 10^{-10} f^{-2} \text{ m Hz}^{-1/2}$
 - 0-10 Hz (256Hz, 16bit, 3 axis)
- **Microphones**
 - $10 \text{ Pa Hz}^{-1/2}$
 - 10-1000Hz (2048Hz, 16bit)
- **RF receivers**
 - $10 \mu\text{V/m}$
 - 1.3GHz (2048Hz, 6x16bit)
- **Residual Gas in Vacuum System**
- **Vacuum contamination Monitor**
- **Weather Station**
 - T (1K), RH (10%), percipitation (10%), Wind (1mph)

- **Tiltmeters**
 - $2 \times 10^{-9} f^{-2} \text{ rad Hz}^{-1/2}$
 - 0-10Hz (256Hz, 16bit, 2 axis)
- **Dust Monitors**
- **Muon (Charged Particle) Detector**
 - $10^{-4} \mu/\text{s}/\text{m}^2$
 - 1 msec (2048Hz, 16bit)
- **Cosmic Rays**
- **Magnetometer**
 - $2 \times 10^{-11} \text{ T.Hz}^{-1/2}$
 - 1 kHz (2048Hz, 3x16bit)
- **Coil magnetometer**
 - $2 \times 10^{-12} \text{ T.Hz}^{-1/2}$
 - 1 kHz (2048Hz, 16bit)
- **Scintillator detector**
- **Power Line Monitor**

Endevco Isotron 2793

<< L1-OAF-C1

Accelerometer Power Supply Power

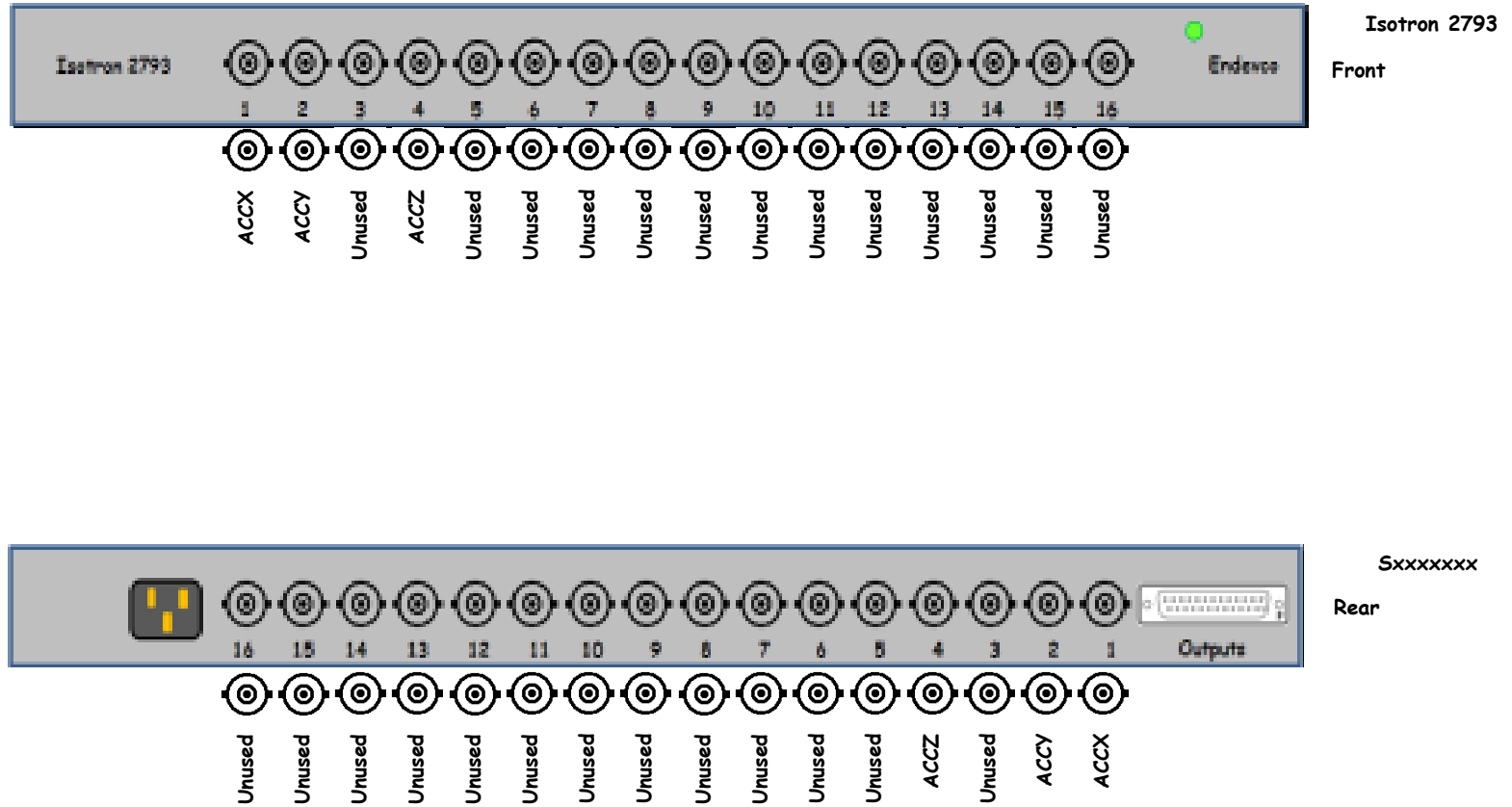

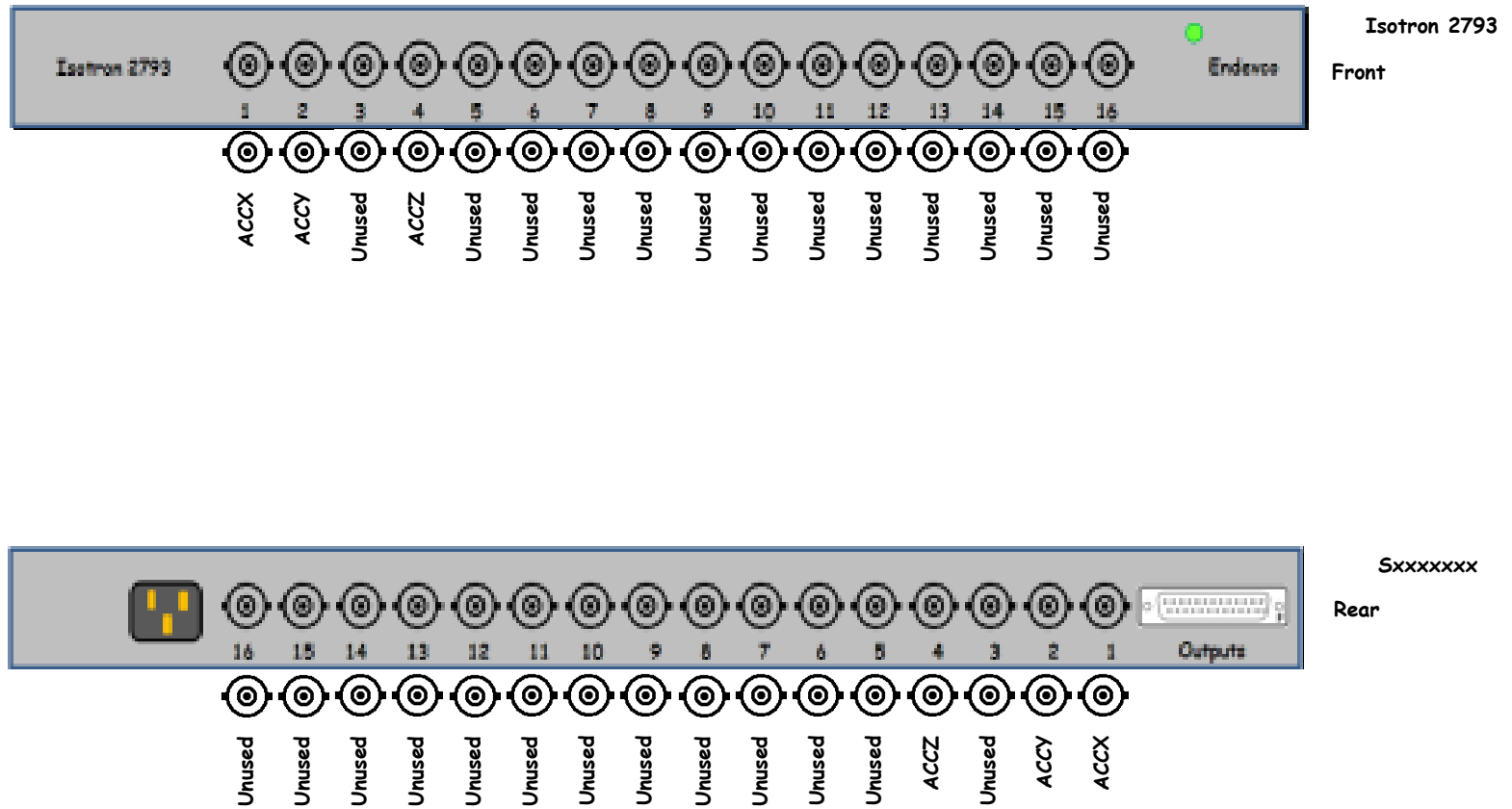



D1001715

Front

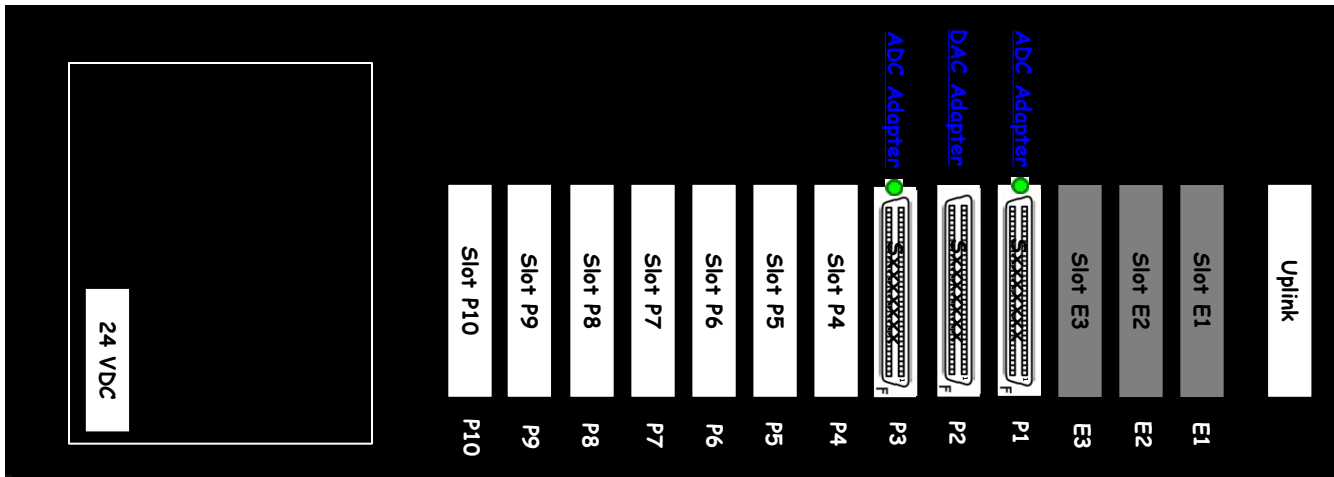

S1103894

Rear

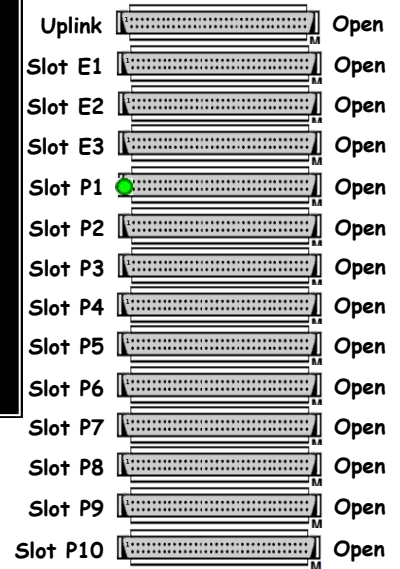

PCIe to Fiber Cable Adapter



Accelerometers (1)

1X5
1X20
1Y20

Isotron Power Supply Model 2793 has 16 channels
This model does NOT come with a DC option.
There is a 3-channel Power Supply that has a DC option,
but it has many other features not desired.

It appears that a short (6") 10-32 to BNC cable can be ordered, but
care should be given to strain relief considerations.

Only Wilcoxon Accelerometers are used for PEM

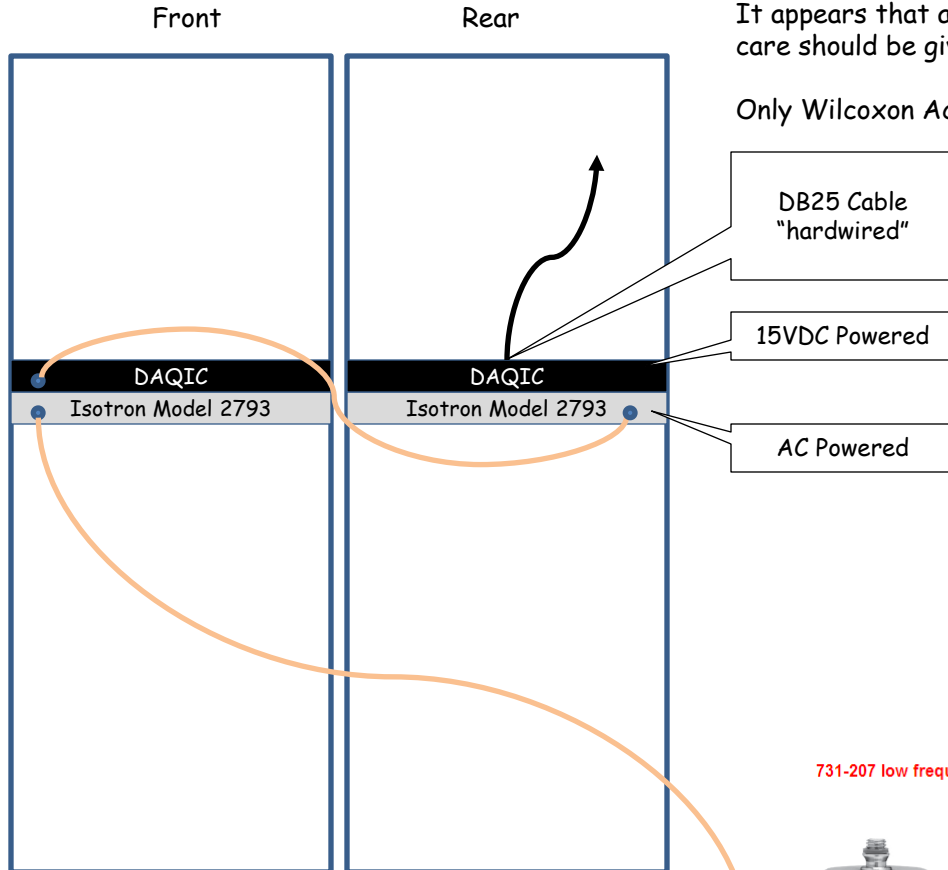

Accelerometer locations:

- | | |
|-----------------------|-------------------|
| 1) PSL X | 16) BSC1 X |
| 2) PSL Y | 17) BSC1 Y |
| 3) PSL Z | 18) BSC1 Z |
| 4) ISCT1 X | 19) BSC2 X |
| 5) ISCT1 Y | 20) BSC2 Y |
| 6) ISCT1 Z | 21) BSC2 Z |
| 7) HAM1 X | 22) BSC3 X |
| 8) HAM1 Y aka HAM6 X | 23) BSC3 Y |
| 9) HAM1 Z | 24) BSC3 Z |
| 10) HAM2 X | 25) HAM6 X |
| 11) HAM2 Y aka HAM6 Y | 26) HAM6 Y |
| 12) HAM2 Z | 27) HAM6 Z |
| 13) HAM3 X | 28) BSC4 X (VEAX) |
| 14) HAM3 Y aka HAM6 Z | 29) BSC4 Y (VEAX) |
| 15) HAM3 Z | 30) BSC4 Z (VEAX) |
| | 31) BSC5 X (VEAY) |
| | 32) BSC5 Y (VEAY) |
| | 33) BSC5 Z (VEAY) |

731-207 low frequency seismic accelerometer

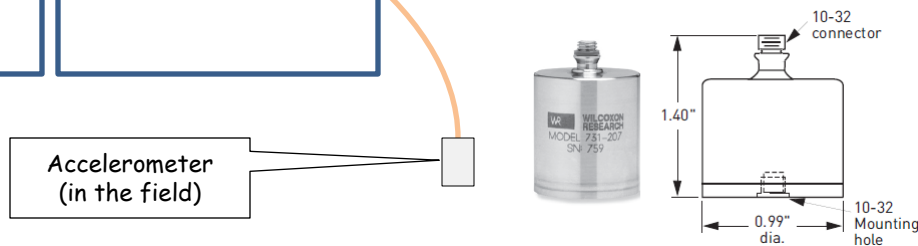

731-207 low frequency seismic accelerometer

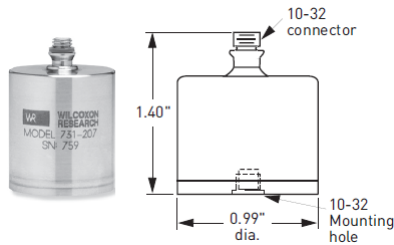

3061

The Endevo model 3061 cable is a non-low noise treated version of the 3090CM12 cable assembly. This cable has a male 10-32 miniature coax connector at one end and a male BNC at the other. The model 3061 is temperature rated from -85°F to +350°F.

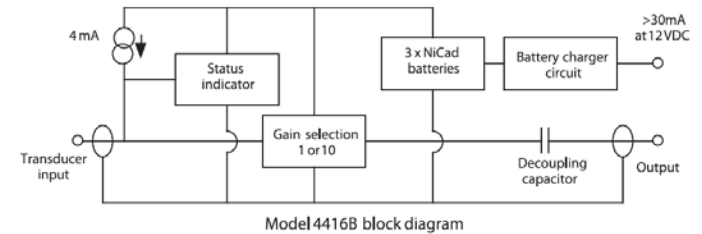
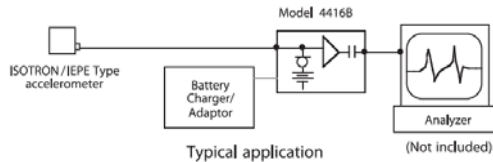
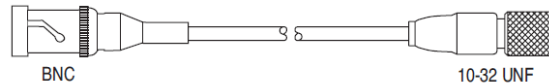

Notes:

1. For ultra-low noise application, model 4416BM1 offers the same basic design without the gain stage.

Avoiding ground loops

In order to provide proper shielding and prevent ground loops, shield and common grounding should be carefully considered. Ground loops are developed when a common line (i.e. signal return/shield) is grounded at two points of differing electrical potential.

For sensors with coaxial cable, the center conductor carries the signal and power, while the outer braiding provides the shielding and signal return. Normally the cable shield is electrically isolated from the sensor housing. This isolates the shield from the mounting point of the machine and prevents ground loops. If a non-isolated sensor is used, it is recommended that an isolated mounting pad be used to break up possible ground loops.

For sensors using two conductor/shielded cable, the signal and power are carried on one lead and the signal common on the other. The cable shield serves to protect the signal from Electrostatic Discharge (ESD) and Electromagnetic Interference (EMI). The shield should be grounded at only one point, normally to the readout equipment.

In all cases, it is very important that the cable shield terminations be properly grounded. Failure to do so in high ESD/EMI environments can result in damage to the sensor electronics.

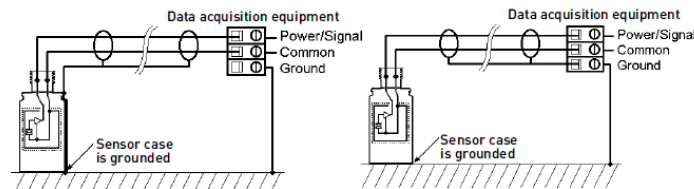

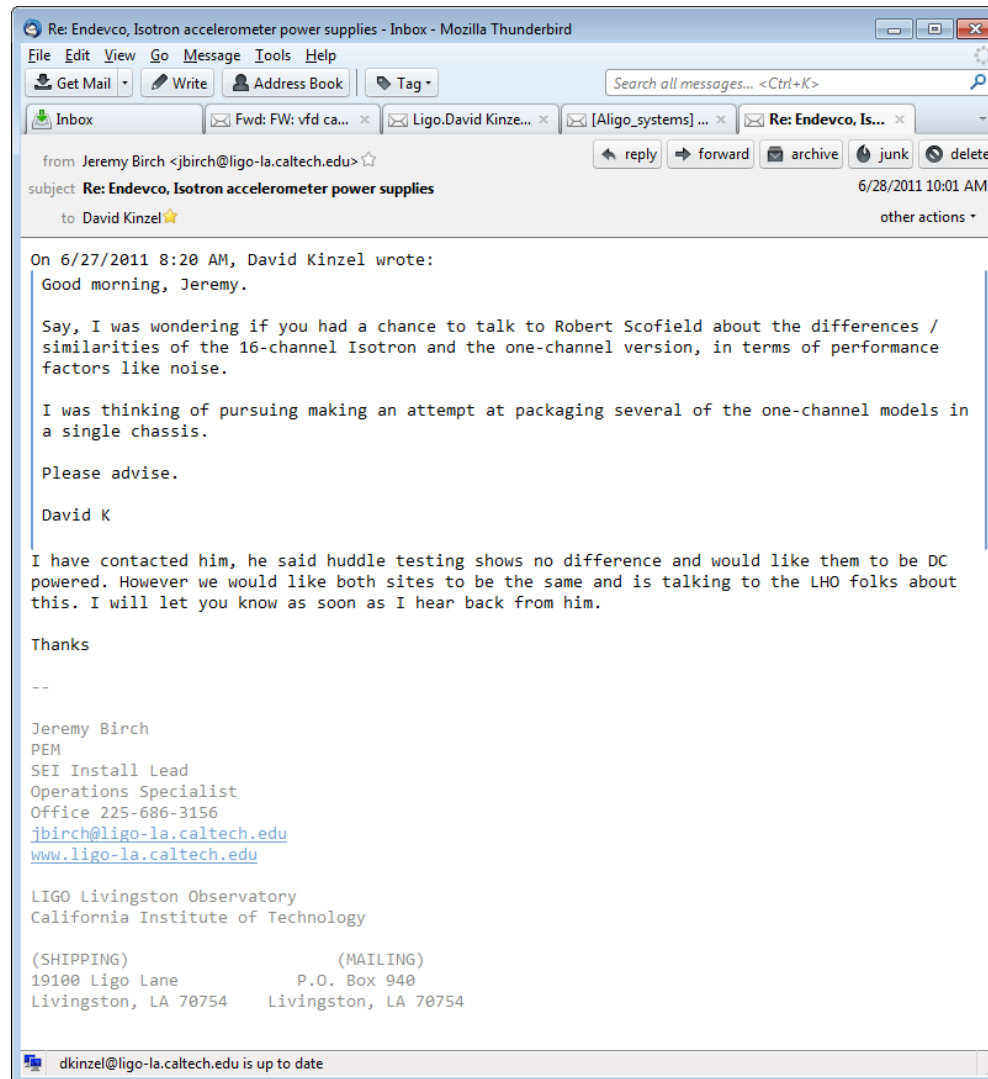

Re: Endecco, Isotron accelerometer power supplies - Inbox - Mozilla Thunderbird

File Edit View Go Message Tools Help

Get Mail Write Address Book Tag Search all messages... <Ctrl+K>

Inbox Fwd: FW: vfd ca... Ligo.David Kinze... [Aligo_systems] ... Re: Endecco, Is...

from Jeremy Birch <jbirch@ligo-la.caltech.edu> ☆

subject Re: Endecco, Isotron accelerometer power supplies

to David Kinzel ☆

6/28/2011 10:01 AM

reply forward archive junk delete other actions

On 6/27/2011 8:20 AM, David Kinzel wrote:

Good morning, Jeremy.

Say, I was wondering if you had a chance to talk to Robert Scofield about the differences / similarities of the 16-channel Isotron and the one-channel version, in terms of performance factors like noise.

I was thinking of pursuing making an attempt at packaging several of the one-channel models in a single chassis.

Please advise.

David K

I have contacted him, he said huddle testing shows no difference and would like them to be DC powered. However we would like both sites to be the same and is talking to the LHO folks about this. I will let you know as soon as I hear back from him.

Thanks

--

Jeremy Birch
PEM
SEI Install Lead
Operations Specialist
Office 225-686-3156
jbirch@ligo-la.caltech.edu
www.ligo-la.caltech.edu

LIGO Livingston Observatory
California Institute of Technology

(SHIPPING) (MAILING)
19100 Ligo Lane P.O. Box 940
Livingston, LA 70754 Livingston, LA 70754

dkinzel@ligo-la.caltech.edu is up to date

There are two antennas of interest.

- 1) Roof Antenna
- 2) CDS High-bay Antenna



The Roof Antenna

- 1) Receiver is located in the MSR
- 2) 219.84 MHz FM

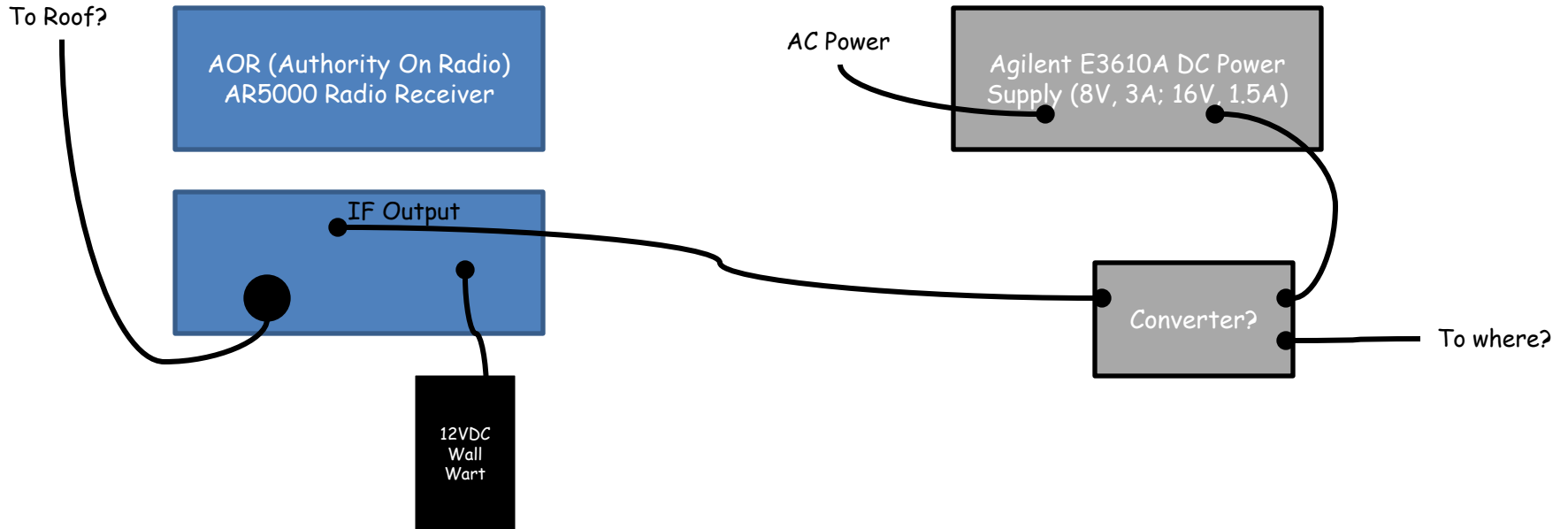



Humidity sensor locations
1) Room 172 - LDR Changing Room

Relative Humidity/Temperature Transmitter with dual Voltage or Current Output, Compact Size
Discontinued Product! See Note Below

HX93 Series



- 4-20mA or 0-1V Output
- RH and Temperature Output
- Compact Size for Mounting Versatility
- Watertight Enclosure
- Accurate to 2.5% RH and 0.6°C

Click for [larger image](#).

[To Order](#) [Specs](#)

The HX93 Series is no longer available. Please see the [HX93A Series](#) as a substitute or contact Sales/Temperature Engineering.

(J.) David Barker says this is the Siemens System



Magnetometer (1)

Magnetometer: Bartington Instruments
MAG-03MC

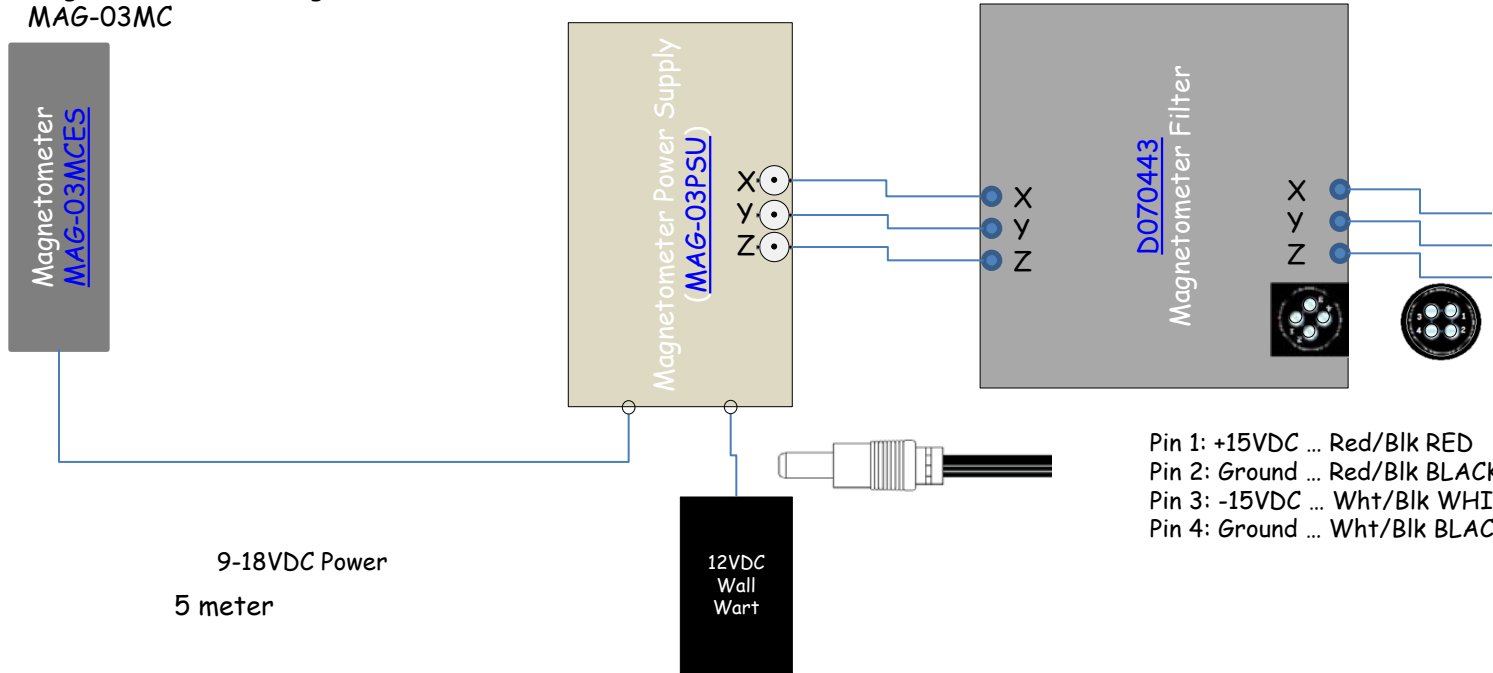

9-18VDC Power
5 meter



[D030574](#)
[T1100382](#)

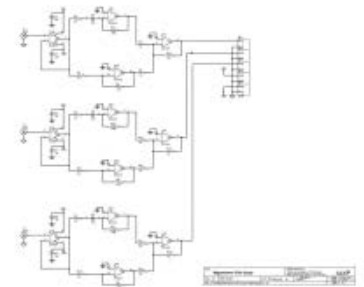

Magnetometers (2) Filter Schematic

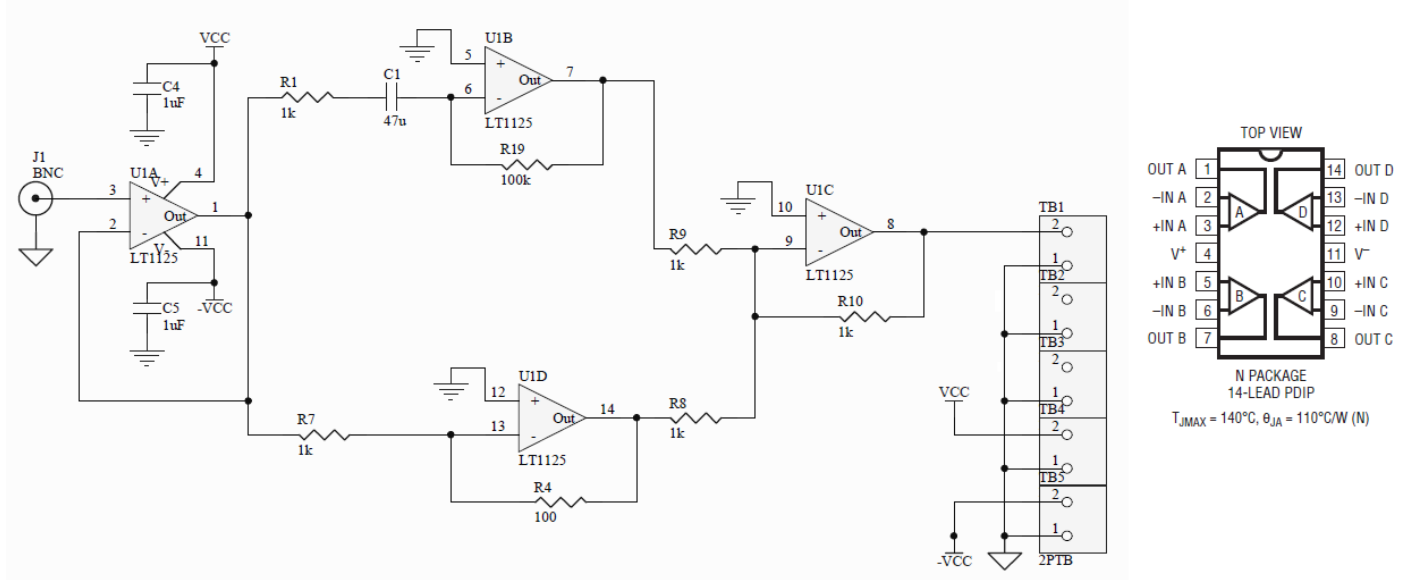

[D030574](#)

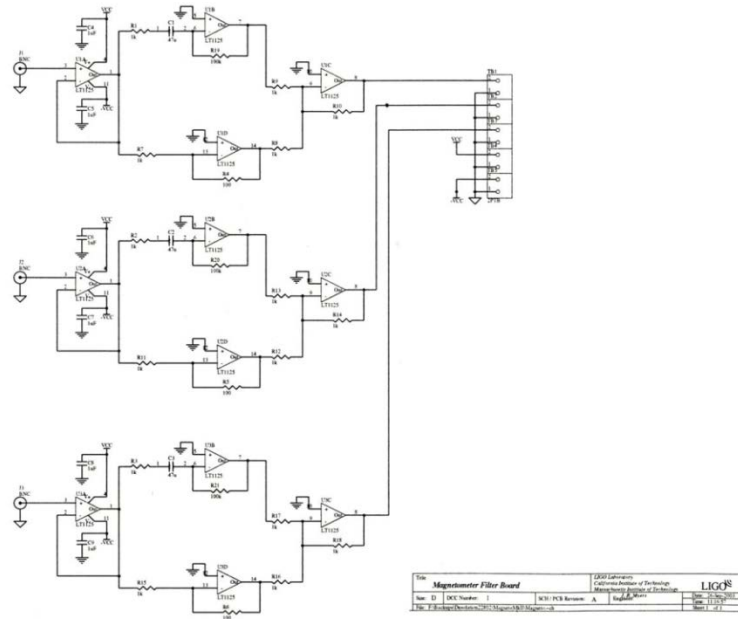

Magnetometers (3) Amplifier Sketch

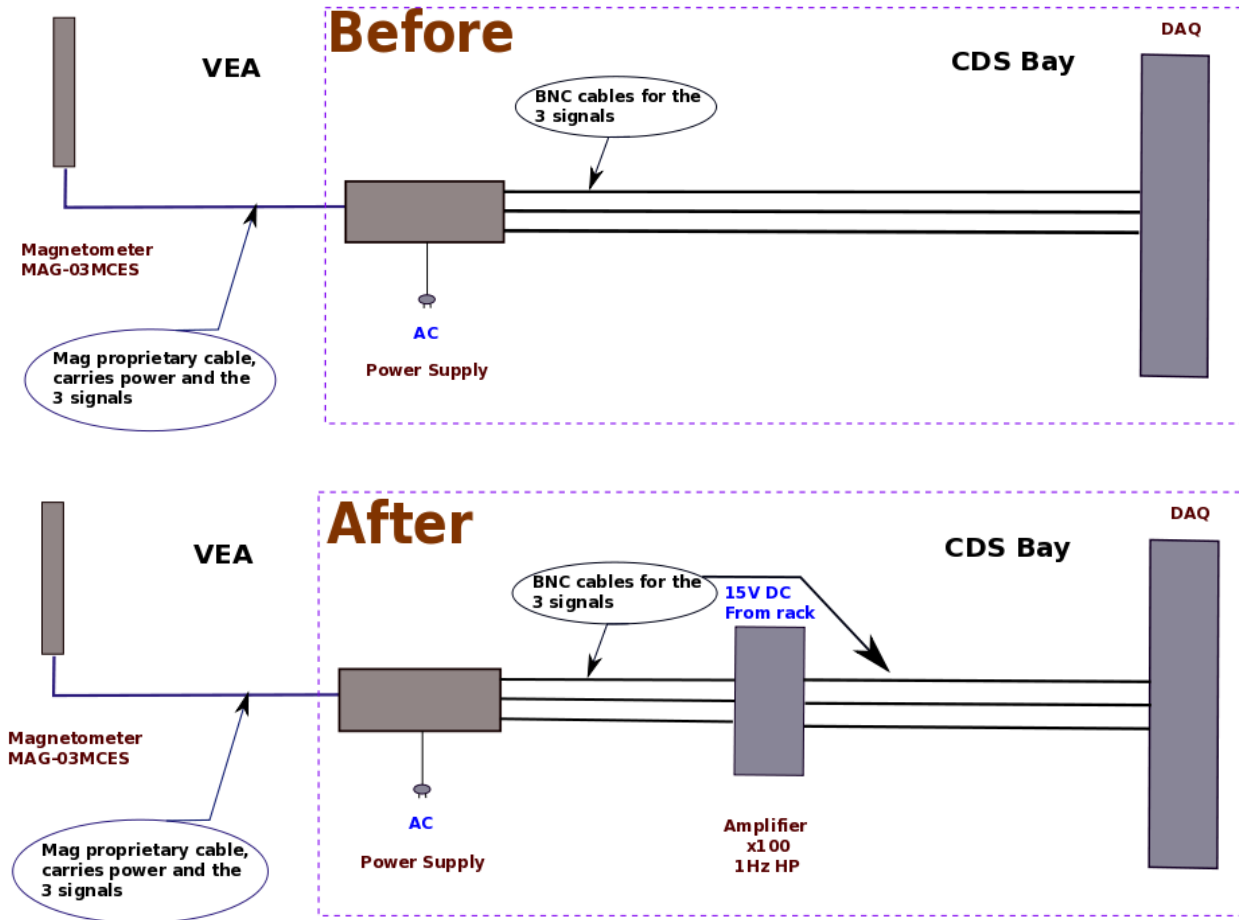

Microphone locations / Pair

- 1) PSL / ISCT1
- 2) ISCT1 / PSL
- 3) HAM1 / HAM3
- 4) HAM3 / HAM1
- 5) BSC2 (aka LVEA) / HAM6
- 6) BSC1 / BSC3
- 7) BSC3 / BSC1
- 8) HAM6 / LVEA
- 9) BSC4 (X) / not paired
- 10) BSC5 (Y) / not paired
- 11) LSR (aka CDS High-bay) / not paired
- 12) VEAX Bay Mic / not paired
- 13) VEAY Bay Mic / not paired

The Manufacturer is Bruel & Kjaer

Since the power supply handles two microphones, the microphones are 'paired' in certain places.

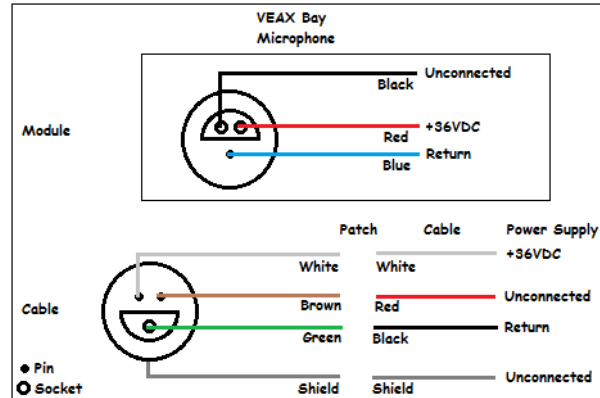

Extension cables are available -
3m, 10m, and 30m

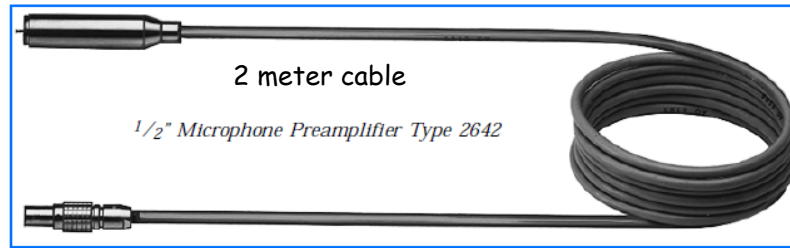

Microphones - Power Adaptor Cable

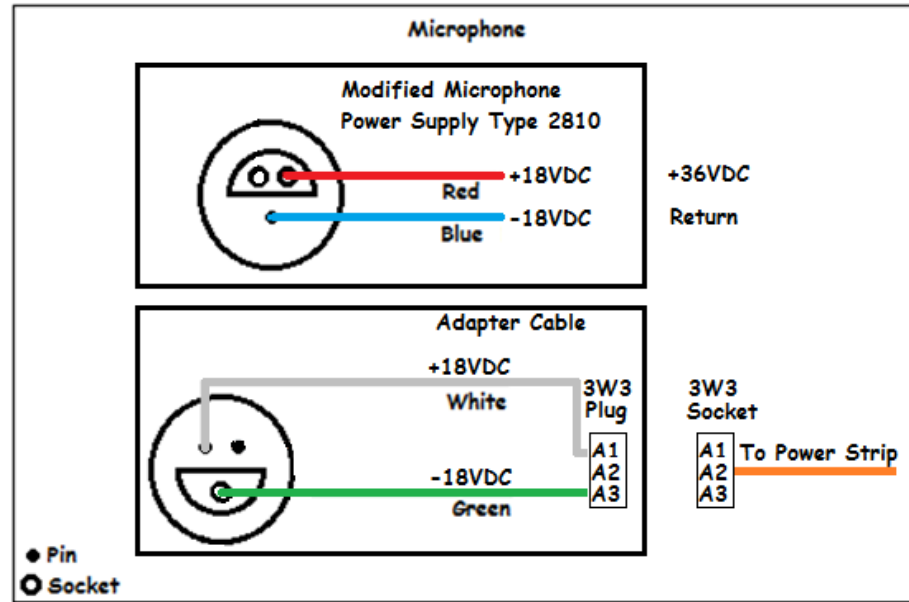

Particle Counters (Dust Monitors)

Dust Monitors are not on during Science Mode due to the acoustic noise. This noise is the air pump. It is always on.

The manufacturer is Pacific Scientific
 Old ones (being replaced) are MET One 227B. (9VDC)
 New ones (replacements) are MET One GT-321. (9VDC, 2A)

These are scattered throughout the LVEA and usually two of them share a power supply via a cable to a junction box. They are powered from the serial interface port. Not sure if this is a homemade adaptation.

The Junction Box needs documentation.

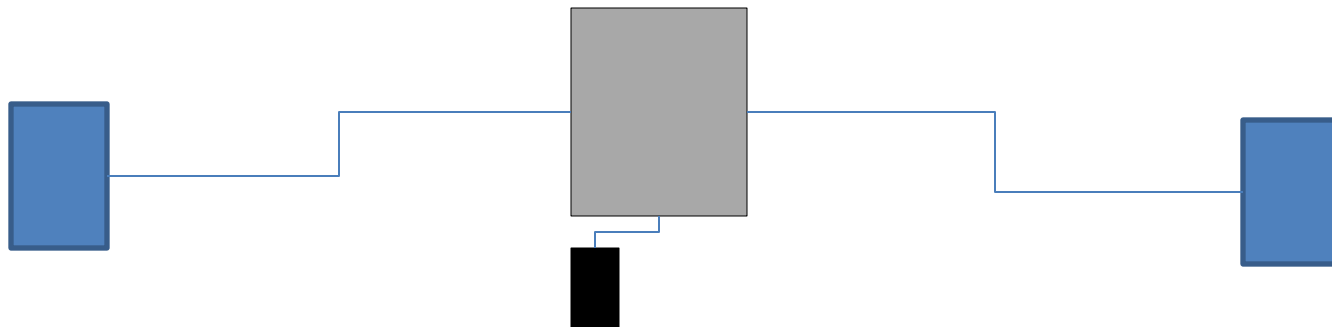
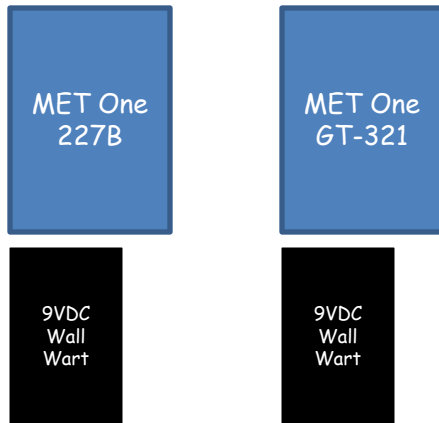

Control DeviceMaster with DB9 Ports

Control DeviceMaster 4 with DB9 Ports

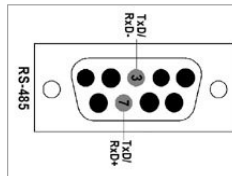

4-Port Power Supply

This table provides the specifications for the power supply shipped with the DeviceMaster 4-port.

| Control Power Supply: 4-Port | |
|------------------------------|----------------|
| Input line frequency | 47 - 63 Hz |
| Input line voltage | 90 - 260 VAC |
| Output voltage | 24VDC |
| Output current | 500 mA @ 24VDC |



Housing Molex P/N:
39-01-4030
Pins Molex P/N:
44485-1211

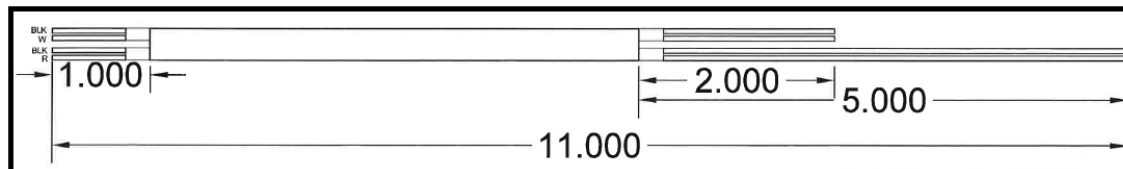
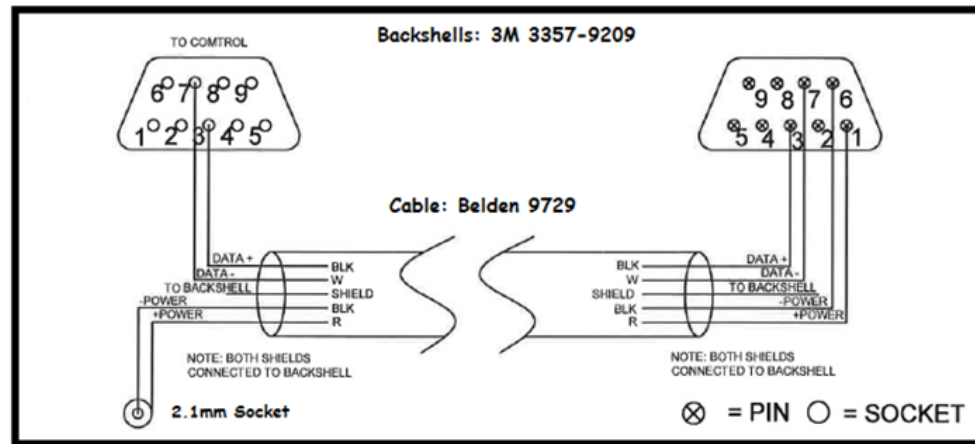

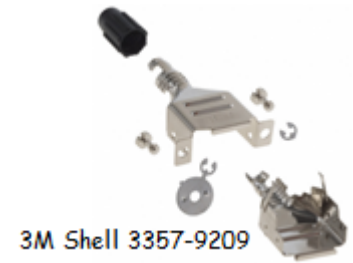
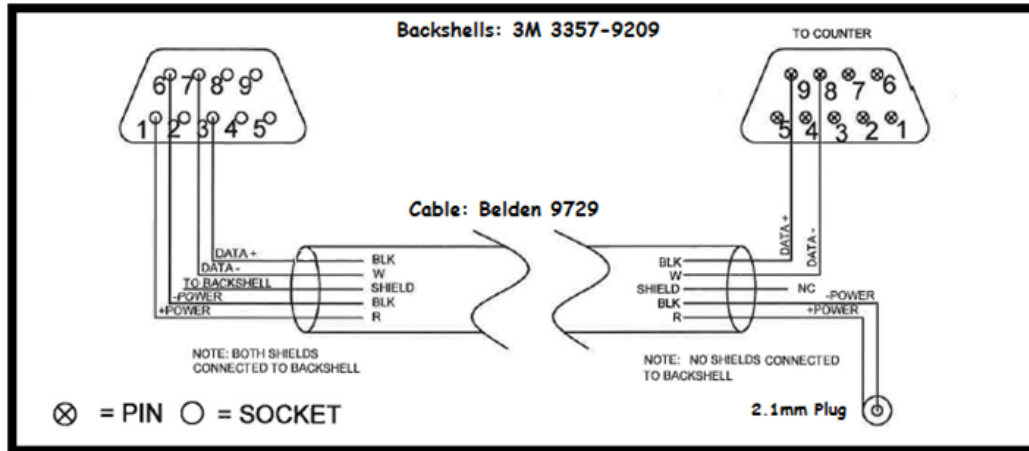

2.1mm Plug
(Note polarity)

This cable is configured to carry both DC Power and RS485 Signals. The 2.1mm Plug can come from a commercially available 2.1mm Cable Assembly. Note the center conductor of the 2.1mm is NEGATIVE. And both shields are tied together and are tied only to the backshell that connects to the cable. The backshell connected to the Particle Counter is NOT tied to the shields.

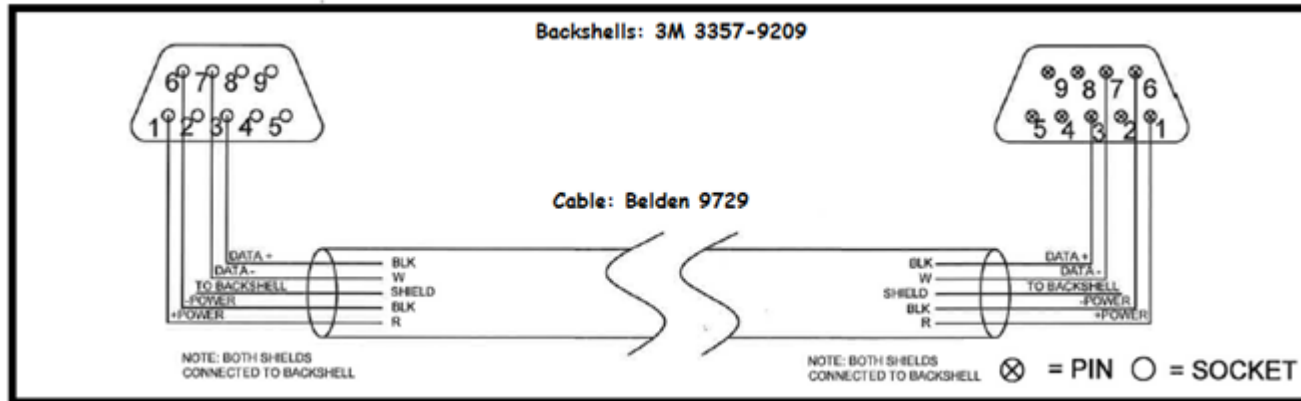

This cable is configured to carry both DC Power and RS485 Signals. Note that both shields are tied together and tied to both backshells.

It is 70' from the L1-FAC-XC1 Rack to the knee of the waterfall in the VEAX.

It is 65' from the L1-FAC-YC1 Rack to the knee of the waterfall in the VEAY.

3M Backshell Assembly

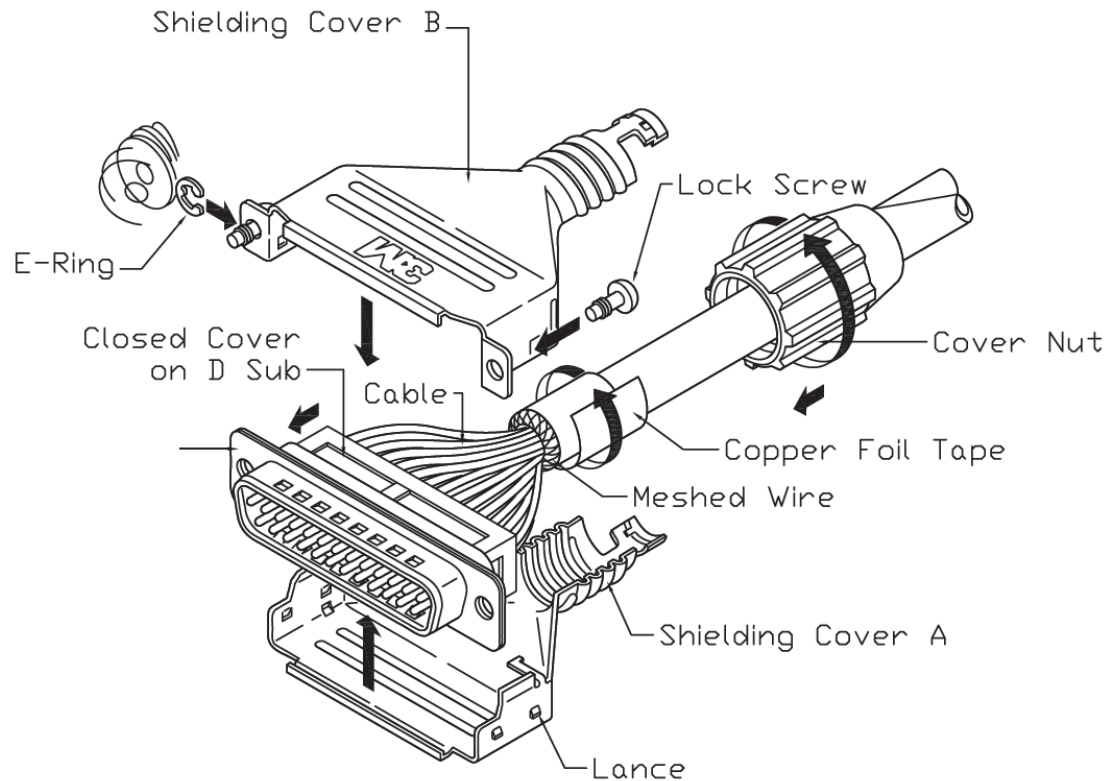

This is a sample drawing of the 3M backshell showing how the E-Ring is attached to the Lock Screw, and showing how the Cover Nut holds the backshell in place.

Particle Counters (Met One 227B)



Model 227 Series Hand-Held Particle Counter
With Temperature/Relative Humidity Probe

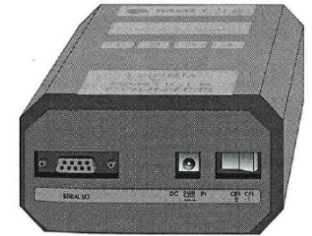
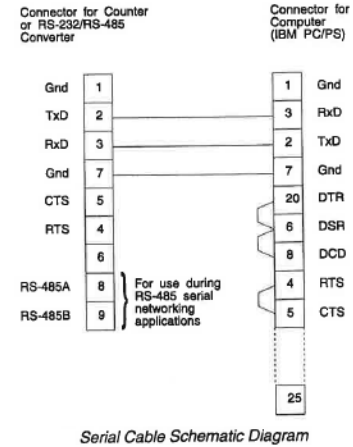

3M Shell 3357-9209

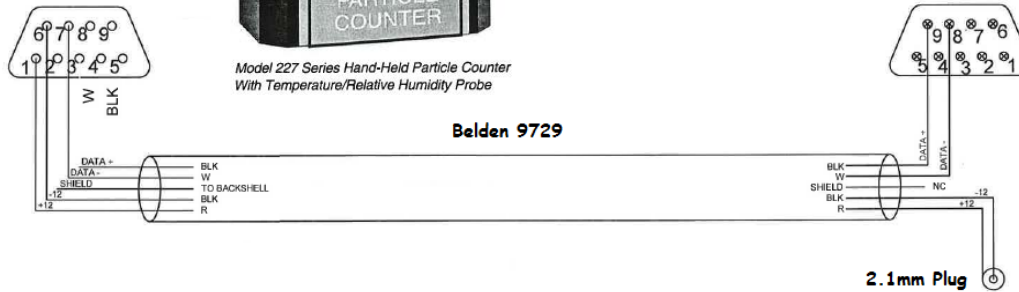

3M Shell 3357-9209

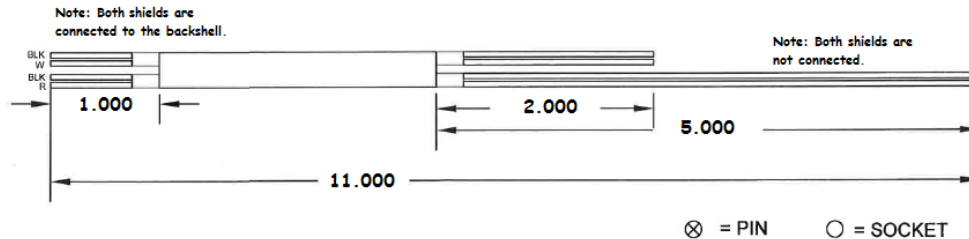

2.1mm Plug
(Note polarity)

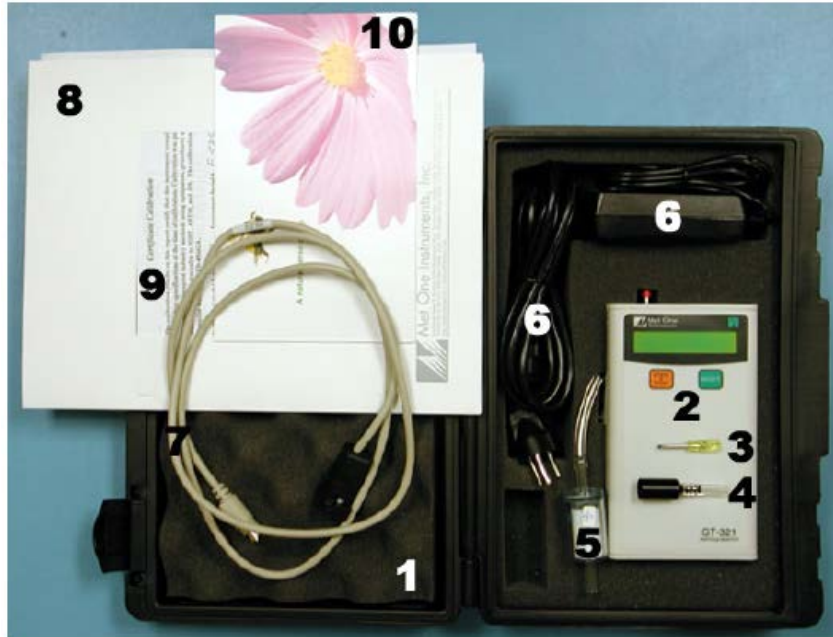

1. Carrying case
2. GT-321 Hand Held Particle Counter
3. Miniature screwdriver
4. Iso-kinetic Sample Probe with a short piece of tubing
5. Zero Particulate Filter (Met One Part Number G3111)
6. Universal AC to DC converter module with IEC AC power cord
7. RS-232 Serial Cable
8. Operation Manual
9. GT-321 Calibration Certificate
10. Color Brochure (optional)

Temperature Sensor locations

- 1) BSC1 (LVEA) - one old, one new
- 2) BSC3 (LVEA)
- 3) BSC4 (VEAX)
- 4) BSC5 (VEAY)

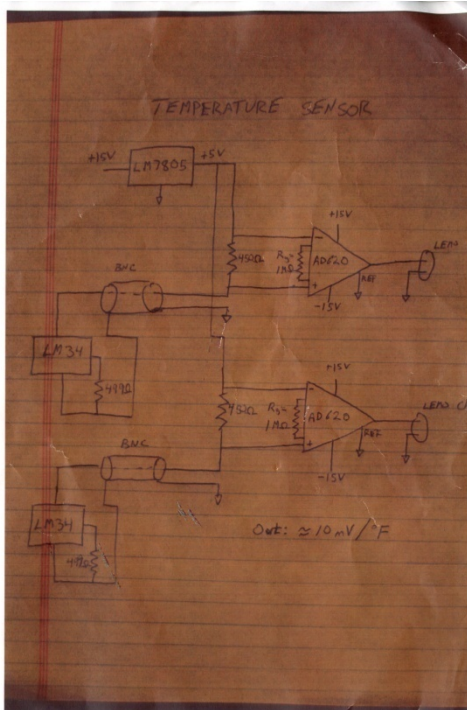

Temperature Sensors include thermocouples:

- 1) Are there any read in the chiller lines? TCS, PSL?
- 2) There are thermocouples in the vacuum system for the N2 tanks.

10:05:43
Tue Jan 9
2007
(Local)

Topic: Commissioning Author: Valera Frolov Tue Jan 9 16:05:43 2007 UTC

Thermocouple readout

According to Rus the thermocouple goes straight to ADC.
The 12 bit ADC is not sensitive enough for the K type Omega thermocouple that has EMF/temp $\approx 40 \mu\text{V}/^\circ\text{C}$.

- Valera Frolov <http://log.ligo-la.caltech.edu/> (ref:1)

NO_KEYWORD Add or Remove Keyword: NO_KEYWORD Submit

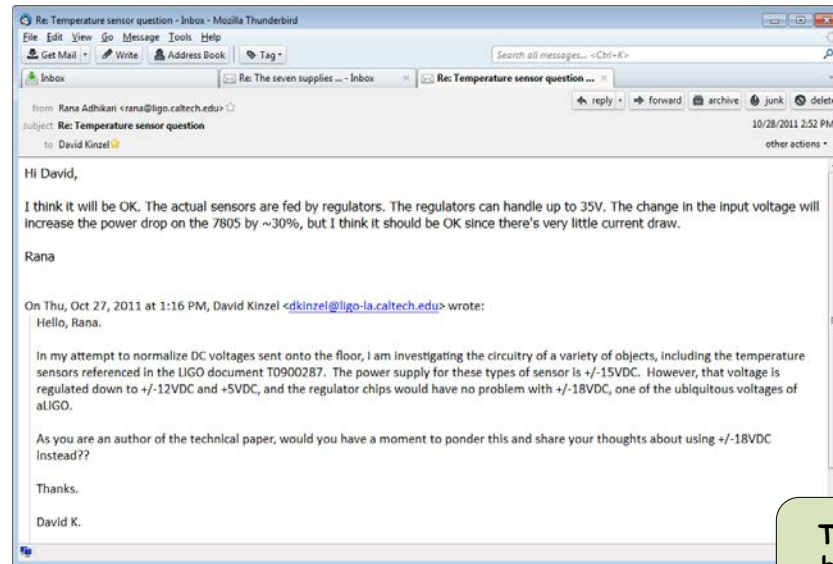

These cables can be replaced with standard +/-18VDC

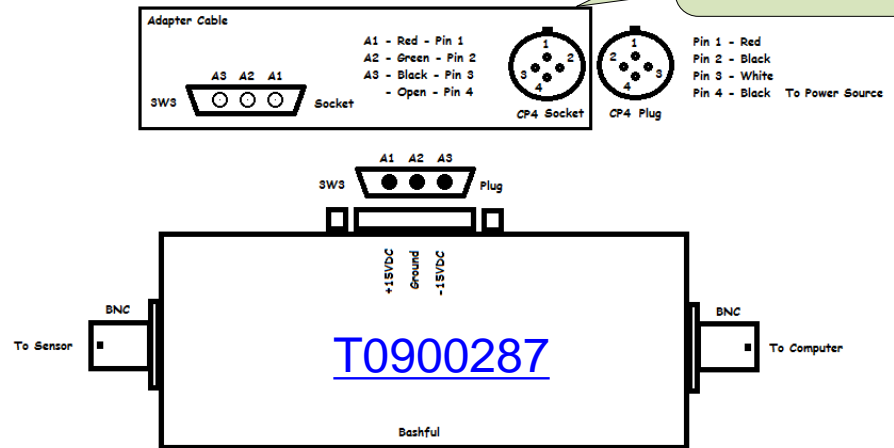

Comments as of 20100525

PEM Voltage Monitor locations:

- 1) LVEA - Rack 1X5 - DAQIC2, BNC Port 13
- 2) VEAX - Rack 1X20 - DAQIC2, BNC Port ?
- 3) VEAY - Rack 1Y20 - DAQIC2, BNC Port 10

This monitor is labeled, "PEM Voltage Monitor No. CAS-Vxx." The circuit board inside says, "LHO EE Power Monitor Board D0000TBD." Documentation is scarce. This device is probably OK for monitoring the single balanced power into which it is plugged in Rack 1X5. It is intended to record the differential between the two phases of the balanced power. But if it is used on any 'real' AC circuit, it creates the potential for a $\frac{1}{2}$ line voltage ground loop between neutral and ground, and another between hot and ground.

Additionally, even in the balanced power situation, NEUTRAL is the wrong designation, for none of the conductors is neutral in a balanced power circuit: it is the negative AC power.

The circuit ties all shields together, so current loops exist between 2 potentially different AC circuits.

And also the cable ties all shields together, creating the same problem.

And most ironic, the monitor in Rack 1X5 is NOT being read at all: there is no signal name, but it is plugged in. (This was NOT true in September 2009 when inventory of the DAQIC signals was last taken.)

At the Y-end, the AC cable has only three BNC connectors. Two are connected to the Voltage Monitor box.

At the X-end, the AC cable has all four BNC connectors, but they are cross-connected to the Voltage Monitor Box: Cable HOT1, NEU1, HOT2, NEU2 are connected to Box HOT2, NEU2, HOT1, NEU1 and I did not check the cable for accuracy. I did note it only has 2 wires coming into the CP4 port, however, but which two is not clear.



LHO EE
Power
Monitor
Board
D000TBD?

Voltage Monitor (2)

Photos as of 20100525



Internal Design and Interfaces as of 20100525

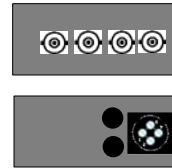
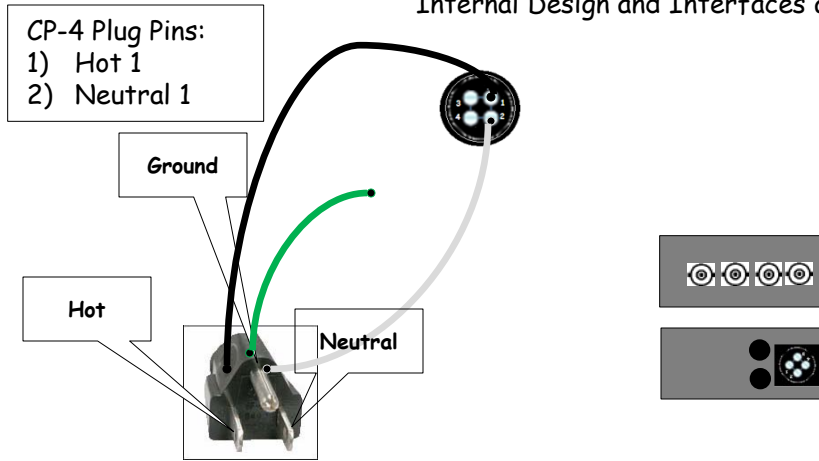

AC Power (input to monitor)
 2 - Fuses - 250V 1/4 A

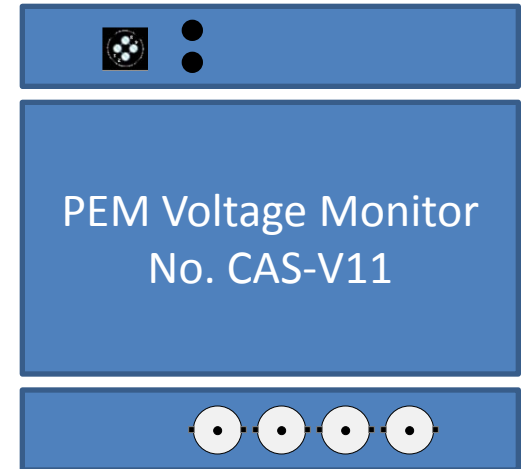

J4 - Neutral 2
 J3 - Hot 2
 J2 - Neutral 1
 J1 - Hot 1

Outputs

CP-4 Socket Pins:
 1) Hot 1 - fused
 2) Neutral 1
 3) Hot 2 - fused
 4) Neutral 2

R1,R3,R5,R7 = 1M Ω
 R2,R4,R6,R8 = 1k Ω
 Fuse1,2 = 250V, 1/4 A

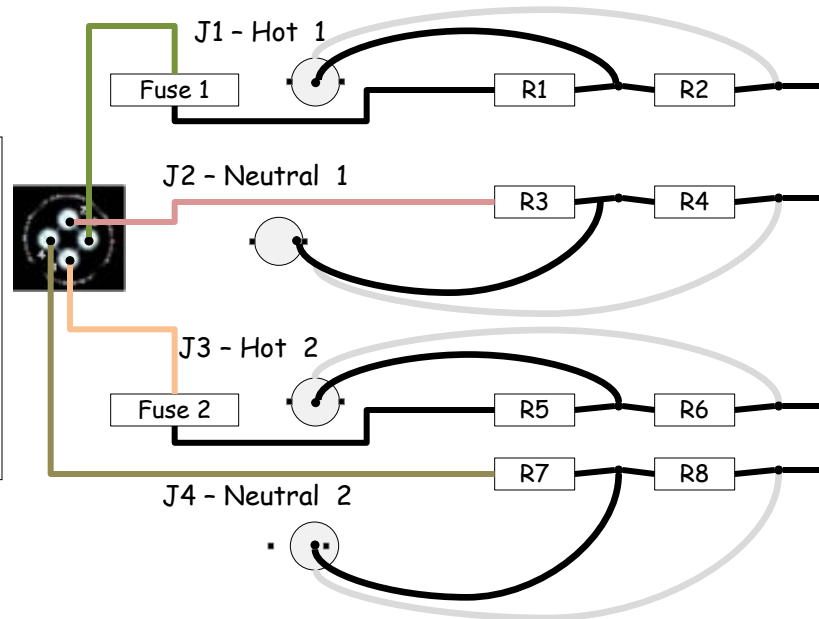

Voltage Monitor (4)

Cable design as of 20100525

Cable: From 4 BNC connectors to 4-Pin Lemo on DAQIC-2

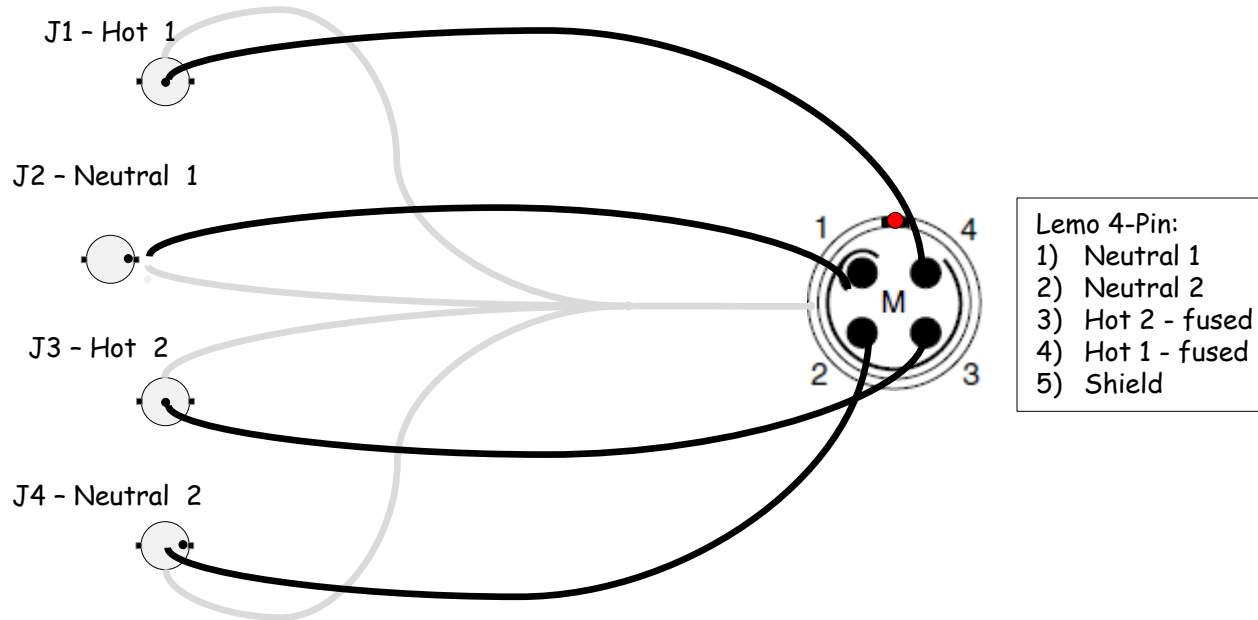

- Lights
- Vacuum Equipment
- Rechargeable Flashlights
- Computer Monitors
- Optical Isolators
- Trouble Lights
- Warning Signs
- Laser Hazard Status Signs
- Laser Danger Signs
- Loudspeakers
- Telephones

Weather Sensor locations

LLO network

LSU network



Partial LVEA Dimensions

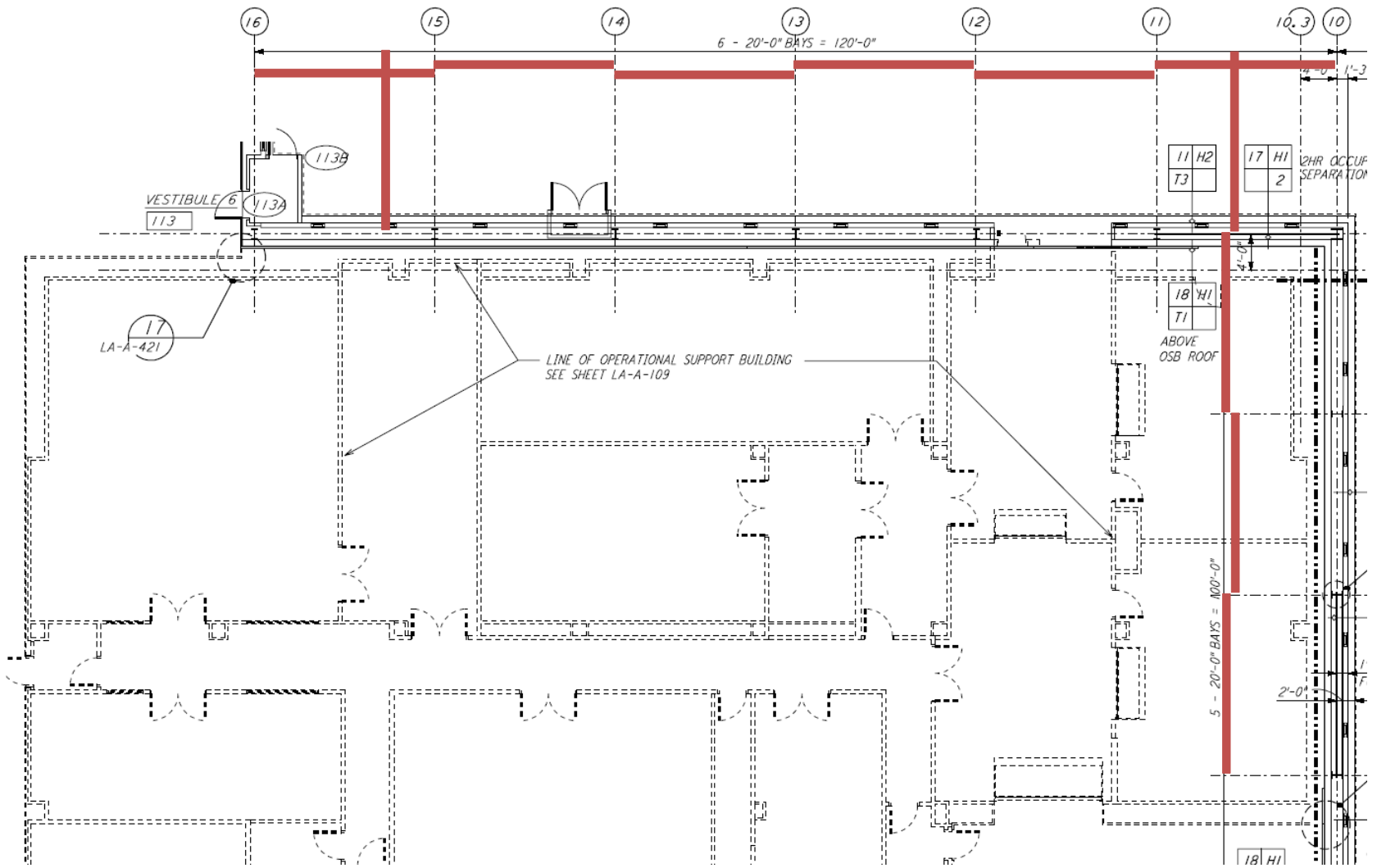

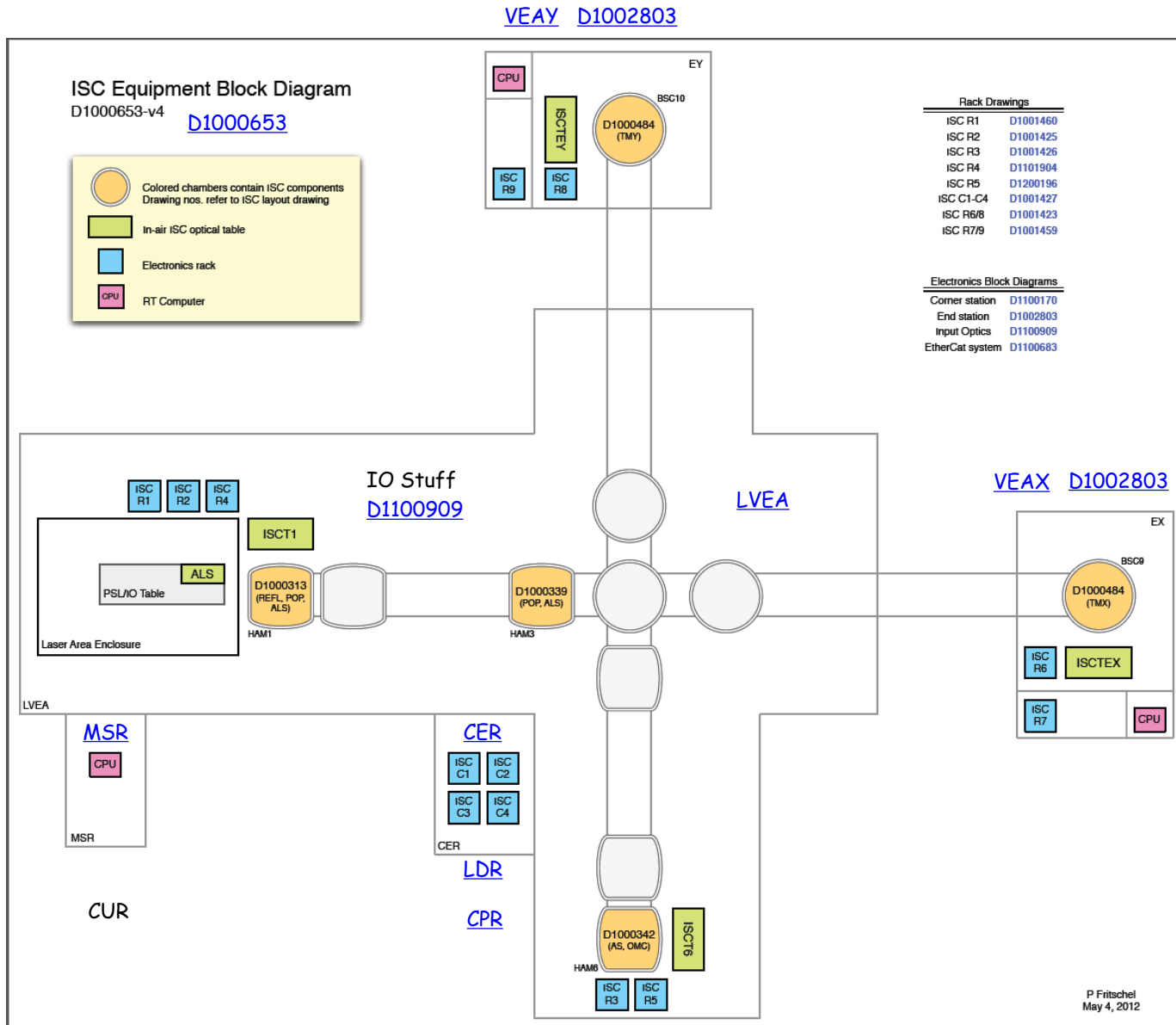

| | | | | | |
|---------------------------------------|----------|----|----------|-----------|--|
| | | 42 | | | |
| | | 41 | | | |
| Beam Diverter Controller | Dxxxxxxx | 40 | SN: | +?@1A | |
| Beam Diverter Controller | Dxxxxxxx | 39 | SN: | +?@1A | |
| | | 38 | | | |
| | | 37 | | | |
| | | 36 | | | |
| | | 35 | | | |
| | | 34 | | | |
| | | 33 | | | |
| OMC Piezo Driver | Dxxxxxxx | 32 | SN: | +?@1A | |
| | | 31 | | | |
| Anti-Alias Chassis (ASC) | D0902783 | 30 | Sxxxxxx | ±18@0.5A | |
| Anti-Alias Chassis (ASC) | D0902783 | 29 | Sxxxxxx | ±18@0.5A | |
| Anti-Alias Chassis (ASC) | D0902783 | 28 | Sxxxxxx | ±18@0.5A | |
| Anti-Alias Chassis (ASC) | D0902783 | 27 | Sxxxxxx | ±18@0.5A | |
| Anti-Alias Chassis (ASC) | D0902783 | 26 | Sxxxxxx | ±18@0.5A | |
| Anti-Alias Chassis (ASC) | D0902783 | 25 | Sxxxxxx | ±18@0.5A | |
| Anti-Alias Chassis (ASC) | D0902783 | 24 | Sxxxxxx | ±18@0.5A | |
| Anti-Alias Chassis (ASC) | D0902783 | 23 | Sxxxxxx | ±18@0.5A | |
| | | 22 | | | |
| 4-Channel Coil Driver (Tip/Tilt REFL) | D1100687 | 21 | SN: | ±18@0.25A | |
| 4-Channel Coil Driver (Tip/Tilt REFL) | D1100687 | 20 | SN: | ±18@0.25A | |
| 4-Channel Coil Driver (Tip/Tilt OMC) | D1100687 | 19 | SN: | ±18@0.25A | |
| 4-Channel Coil Driver (Tip/Tilt OMC) | D1100687 | 18 | SN: | ±18@0.25A | |
| 4-Channel Coil Driver (Tip/Tilt OMC) | D1100687 | 17 | SN: | ±18@0.25A | |
| Anti-Image Chassis (ASC) | D070081 | 16 | Sxxxxxxx | ±18@0.5A | |
| Anti-Image Chassis (ASC) | D070081 | 15 | Sxxxxxxx | ±18@0.5A | |
| | | 14 | | | |
| | | 13 | | | |
| 11asc0 I/O Extension Chassis | D1001715 | 12 | SN: | +24@5A | |
| | | 11 | | | |
| | | 10 | | | |
| | | 9 | | | |
| Anti-Alias Chassis (LSC) | D0902783 | 8 | Sxxxxxx | ±18@0.5A | |
| Anti-Alias Chassis (LSC) | D0902783 | 7 | Sxxxxxx | ±18@0.5A | |
| Anti-Image Chassis (LSC) | D070081 | 6 | Sxxxxxxx | ±18@0.5A | |
| | | 5 | | | |
| | | 4 | | | |
| 11lsc0 I/O Extension Chassis | D1001715 | 3 | SN: | +24@5A | |
| | | 2 | | | |
| | | 1 | | | |
| | | | | | |

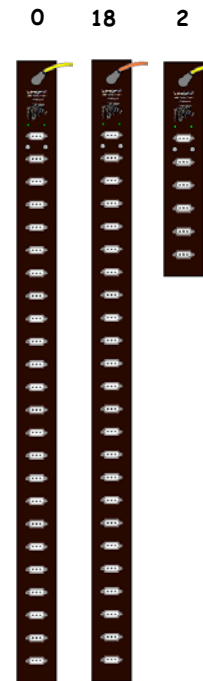

IO Diagram: [D1100909](#)

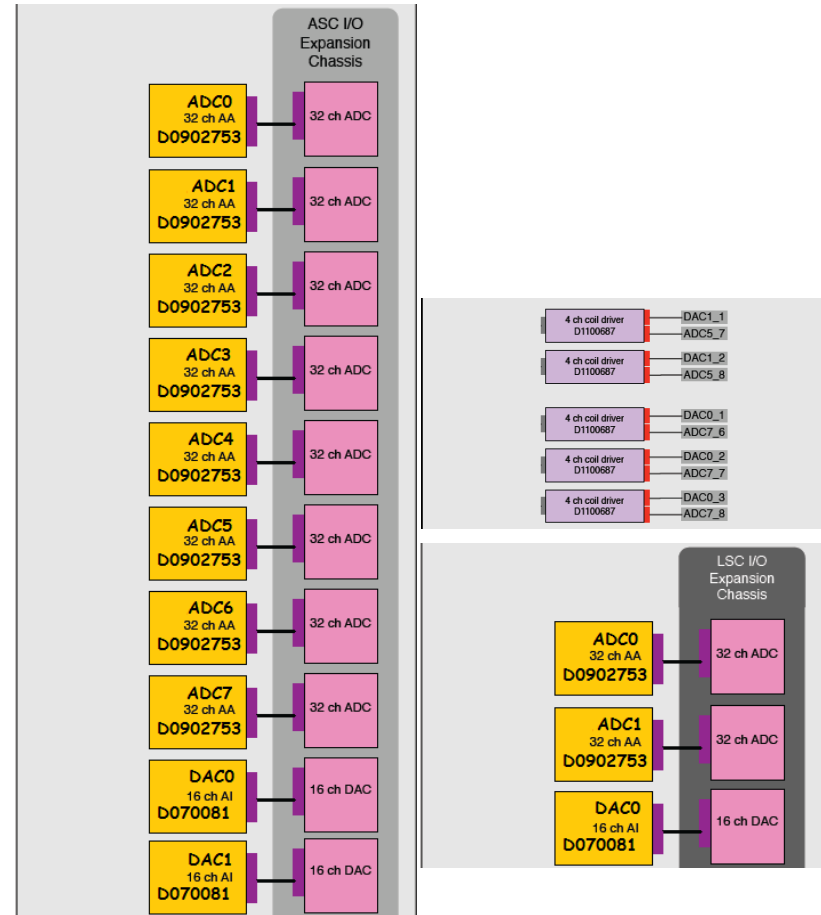
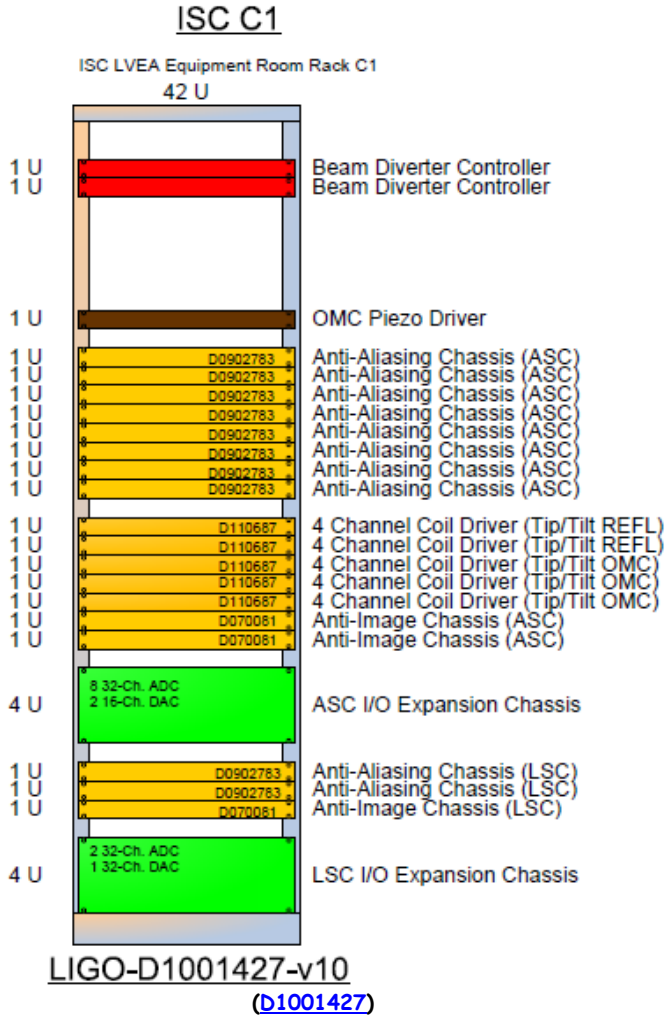

([D1100170](#))

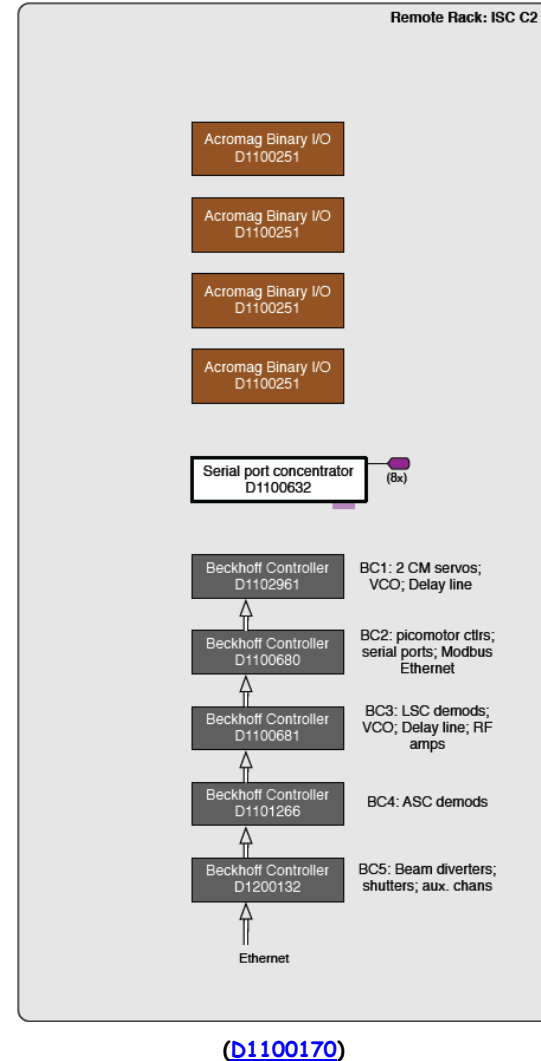
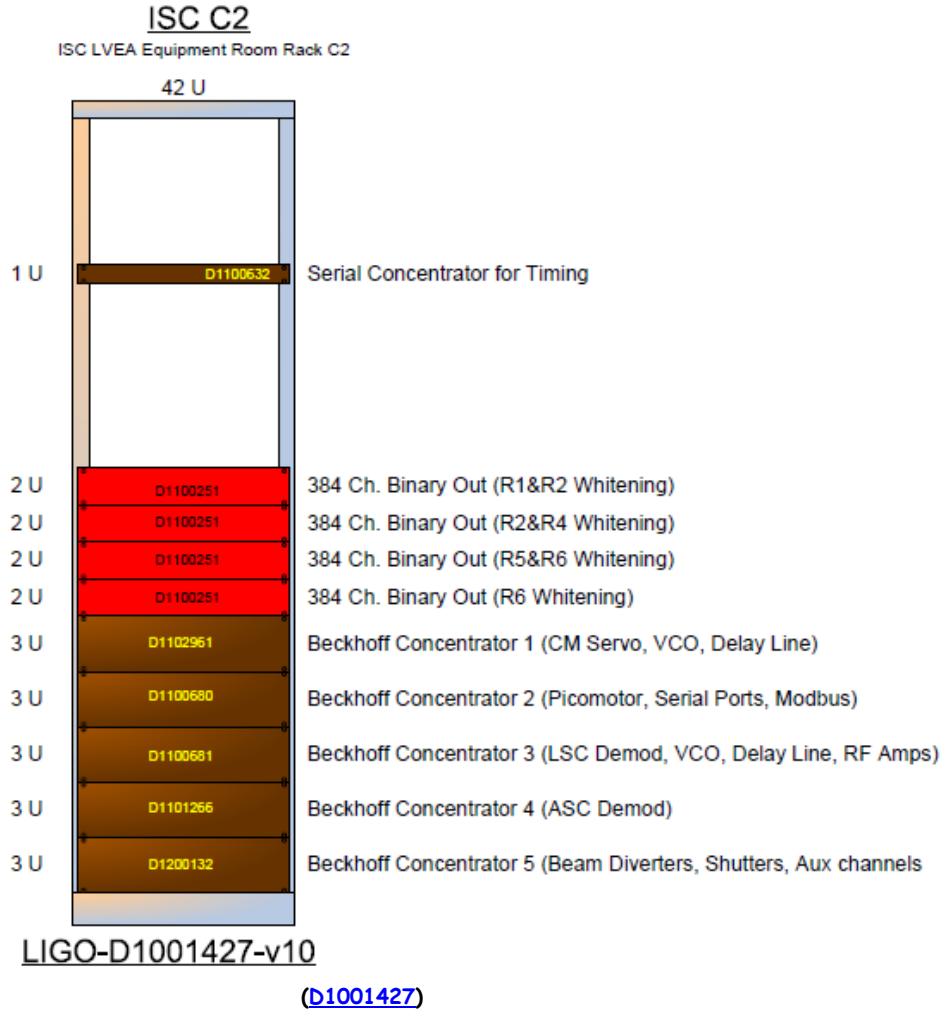

L1-ISC-C3

ISC LVEA Rack 3 Layout ([LIGO-D1001427](#)) ([D1100170](#)) ([S1201188](#))

| | | | | |
|---|--------------------------|----|----------|----------------|
| RF Patch Panel 7 | Dxxxxxxx | 42 | Sxxxxxxx | No Power |
| RF Patch Panel 8 | Dxxxxxxx | 41 | Sxxxxxxx | No Power |
| RF Patch Panel 9 (TCS) | Dxxxxxxx | 40 | Sxxxxxxx | No Power |
| | | 39 | | |
| | | 38 | | |
| | | 37 | | |
| | | 36 | | |
| | | 35 | | |
| | | 34 | | |
| | | 33 | | |
| 21.5 MHz RF Source | D080702 | 32 | Sxxxxxxx | +12VDC, ±24VDC |
| 21.5 MHz Distribution Amplifier | D1000124 | 31 | Sxxxxxxx | ±17VDC, ±24VDC |
| 35.5 MHz RF Source | D080702 | 30 | Sxxxxxxx | +12VDC, ±24VDC |
| 35.5 MHz Distribution Amplifier | D1000124 | 29 | Sxxxxxxx | ±17VDC, ±24VDC |
| | | 28 | | |
| | | 27 | | |
| | | 26 | | |
| 80 MHz RF Source | D080702 | 25 | Sxxxxxxx | +12VDC, ±24VDC |
| 80 MHz Distribution Amplifier | D1000124 | 24 | Sxxxxxxx | ±17VDC, ±24VDC |
| 40 MHz Frequency Divider | D1002182 | 23 | Sxxxxxxx | ±17VDC, ±24VDC |
| 40 MHz Distribution Amplifier | D1000124 | 22 | Sxxxxxxx | ±17VDC, ±24VDC |
| 10 MHz Frequency Divider | D1100974 | 21 | Sxxxxxxx | ±17VDC, ±24VDC |
| 10 MHz Distribution Amplifier | D1000124 | 20 | Sxxxxxxx | ±17VDC, ±24VDC |
| RF Amplifier Concentrator 1 | D1100262 | 19 | Sxxxxxxx | ±17VDC, ±24VDC |
| | | 18 | SN: | ±18VDC |
| RF Amplifier Concentrator 2 | D1100262 | 17 | SN: | ±18VDC |
| | | 16 | | |
| | | 15 | | |
| | | 14 | | |
| | | 13 | | |
| | | 12 | | |
| Timing Comparator / Frequency Counter | D1001370 | 11 | Sxxxxxxx | +12VDC |
| Timing Fanout Module | D080534 | 10 | Sxxxxxxx | +12VDC |
| | | 9 | | |
| | | 8 | | |
| | | 7 | | |
| | | 6 | | |
| | | 5 | | |
| | | 4 | | |
| | | 3 | | |
| | | 2 | | |
| | | 1 | | |

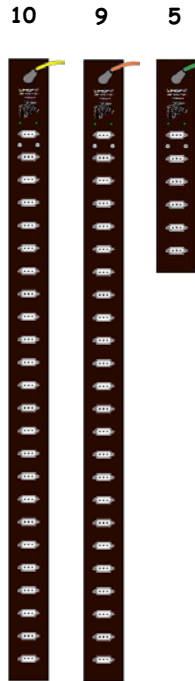

ISC C3

ISC LVEA Equipment Room Rack C3

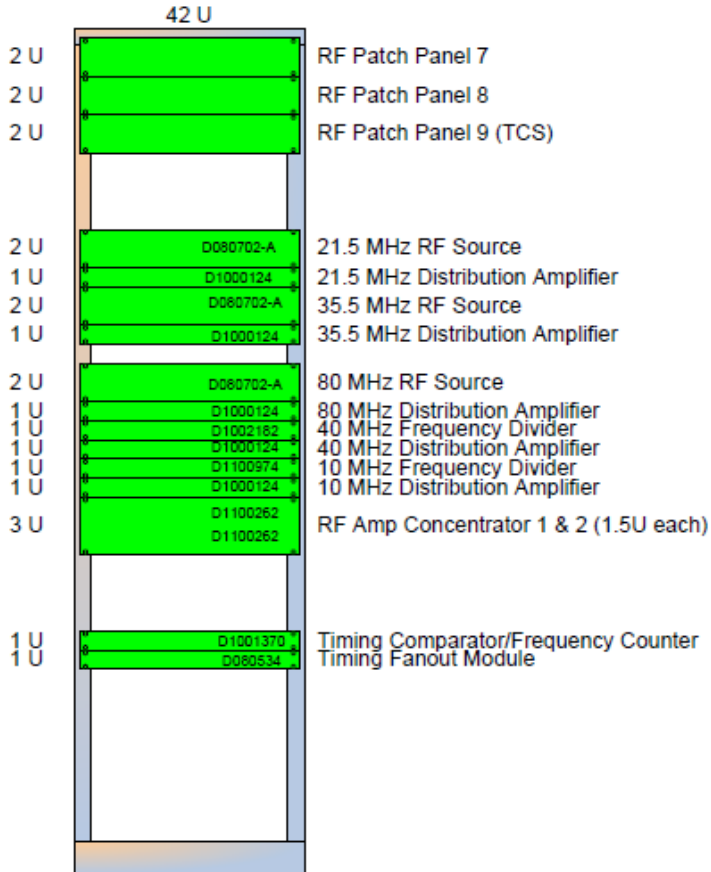

LIGO-D1001427-v10

([D1001427](#))

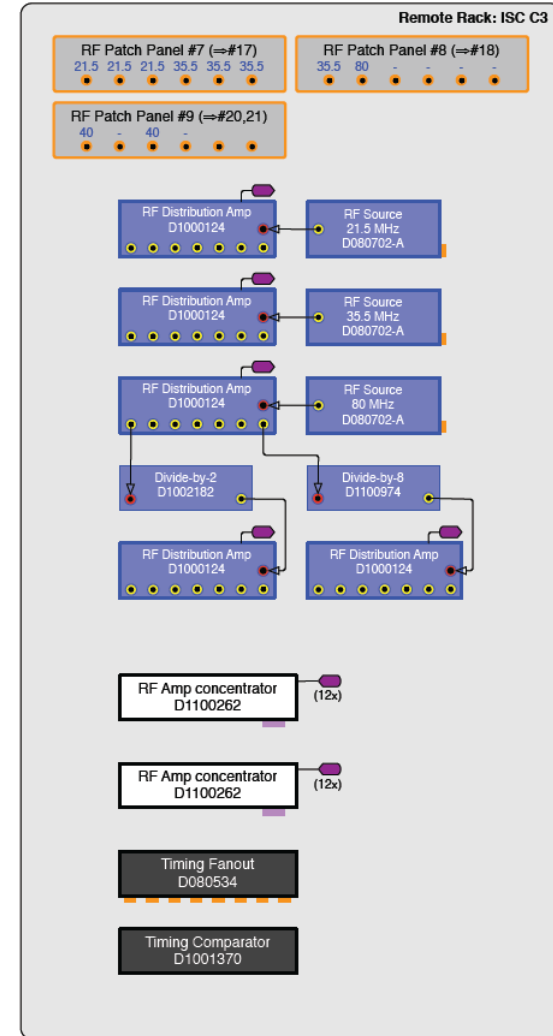

([D1100170](#))

L1-ISC-C4

ISC LVEA Rack 4 Layout ([LIGO-D1001427](#)) ([D1100170](#)) ([S1201189](#))

| | | | | |
|--|--------------------------|----|----------|----------------|
| RF Patch Panel 1 | Dxxxxxxx | 42 | Sxxxxxxx | No Power |
| RF Patch Panel 2 | Dxxxxxxx | 41 | Sxxxxxxx | No Power |
| RF Patch Panel 3 | Dxxxxxxx | 40 | Sxxxxxxx | No Power |
| RF Patch Panel 4 | Dxxxxxxx | 39 | Sxxxxxxx | No Power |
| RF Patch Panel 5 | Dxxxxxxx | 38 | Sxxxxxxx | No Power |
| RF Patch Panel 6 | Dxxxxxxx | 37 | Sxxxxxxx | No Power |
| Aeroflex 2023A Diagnostics | Dxxxxxxx | 36 | Sxxxxxxx | No Power |
| 9.099 / 8.684 MHz RF Source | D080702 | 35 | Sxxxxxxx | No Power |
| 9.099 / 8.684 MHz Distribution Amplifier | D1000124 | 34 | Sxxxxxxx | No Power |
| 9.099 / 8.684 MHz Harmonic Generator | Dxxxxxxx | 33 | Sxxxxxxx | No Power |
| 9.099 / 8.684 MHz Harmonic Power Supply | D1002735 | 32 | Sxxxxxxx | No Power |
| 18 MHz Distribution Amplifier | D1000124 | 31 | Sxxxxxxx | No Power |
| 27 MHz Distribution Amplifier | D1000124 | 30 | Sxxxxxxx | No Power |
| 36 MHz Distribution Amplifier | D1000124 | 29 | Sxxxxxxx | Power |
| 45 MHz Distribution Amplifier | D1000124 | 28 | Sxxxxxxx | +12VDC, ±24VDC |
| 90 MHz Distribution Amplifier | D1000124 | 27 | Sxxxxxxx | ±17VDC, ±24VDC |
| 135 MHz Distribution Amplifier | D1000124 | 26 | Sxxxxxxx | |
| | | 25 | | |
| | | 24 | | |
| | | 23 | Sxxxxxxx | From D1002735 |
| | | 22 | Sxxxxxxx | ±17VDC, ±24VDC |
| | | 21 | Sxxxxxxx | ±17VDC, ±24VDC |
| | | 20 | Sxxxxxxx | ±17VDC, ±24VDC |
| | | 19 | Sxxxxxxx | ±17VDC, ±24VDC |
| | | 18 | Sxxxxxxx | ±17VDC, ±24VDC |
| | | 17 | Sxxxxxxx | ±17VDC, ±24VDC |
| | | 16 | Sxxxxxxx | ±17VDC, ±24VDC |
| | | 15 | | |
| | | 14 | | |
| 24.078 / 22.993 MHz RF Source | D080702 | 13 | Sxxxxxxx | +12VDC, ±24VDC |
| 24.078 / 22.993 MHz Distribution Amplifier | D1000124 | 12 | Sxxxxxxx | ±17VDC, ±24VDC |
| 71 MHz RF Source | D080702 | 11 | Sxxxxxxx | +12VDC, ±24VDC |
| 71 MHz Distribution Amplifier | D1000124 | 10 | Sxxxxxxx | ±17VDC, ±24VDC |
| | | 9 | | |
| | | 8 | | |
| | | 7 | | |
| | | 6 | | |
| | | 5 | | |
| | | 4 | | |
| | | 3 | | |
| | | 2 | | |
| | | 1 | | |

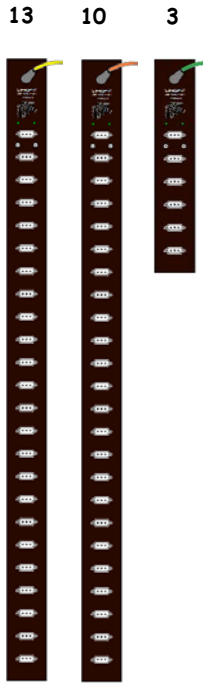

ISC C4

ISC LVEA Equipment Room Rack C3

42 U

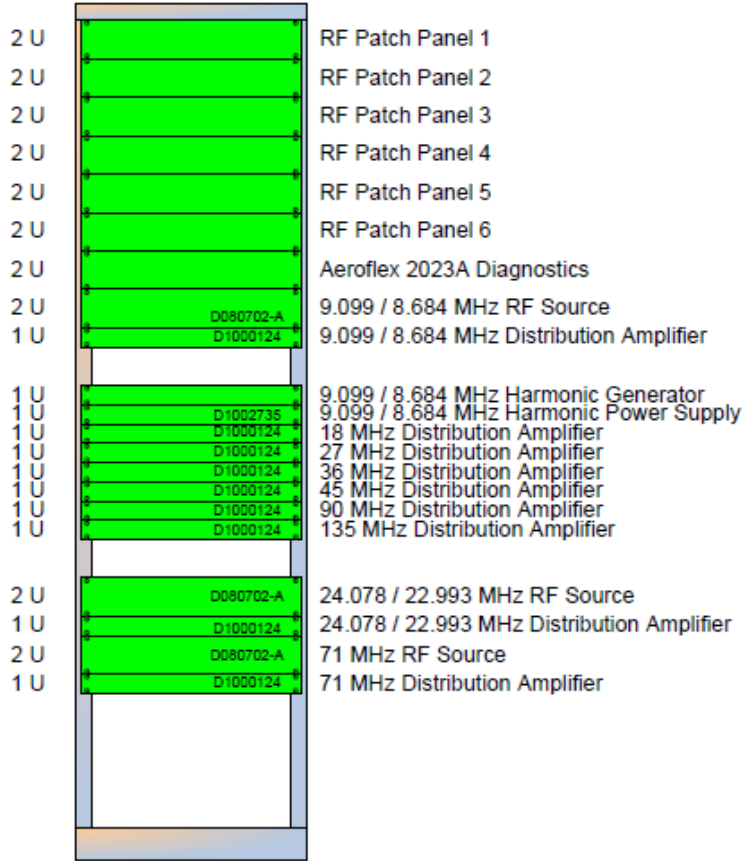

LIGO-D1001427-v10

([D1001427](#))

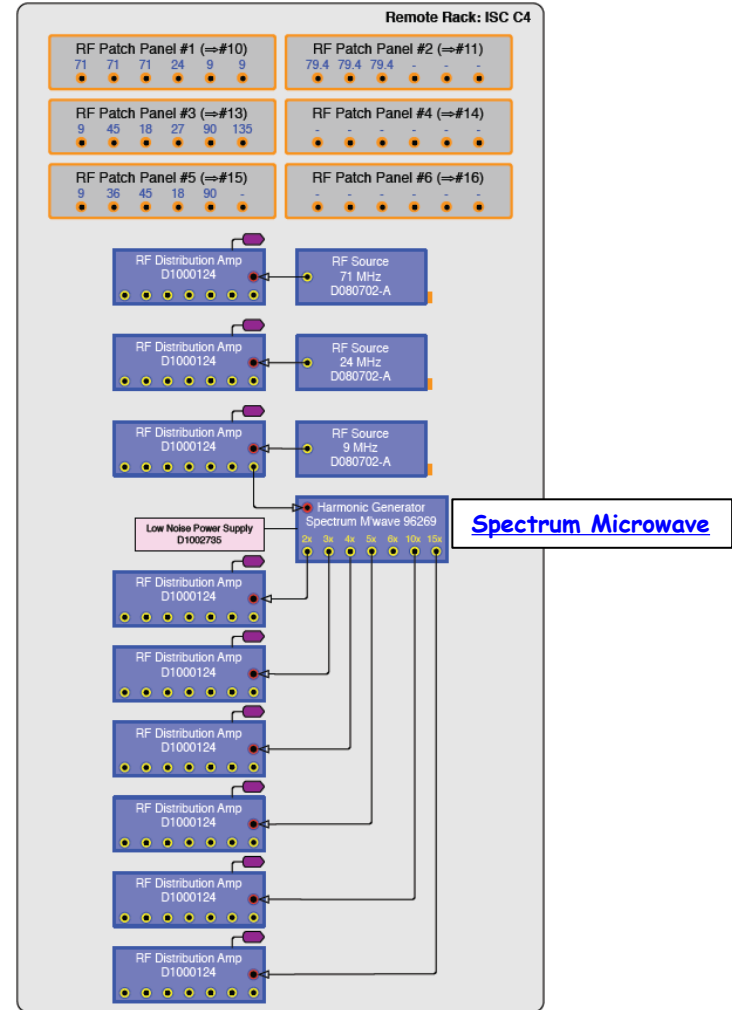

([D1100170](#))

L1-ISC-C1 Details

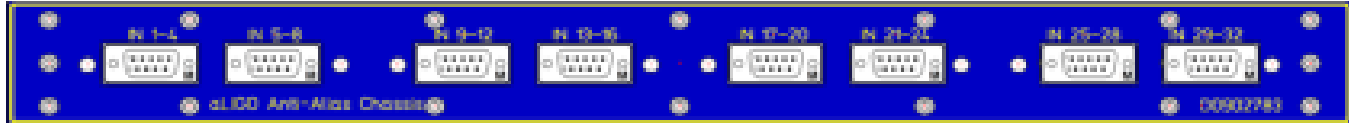

[D0902783](#)

Front

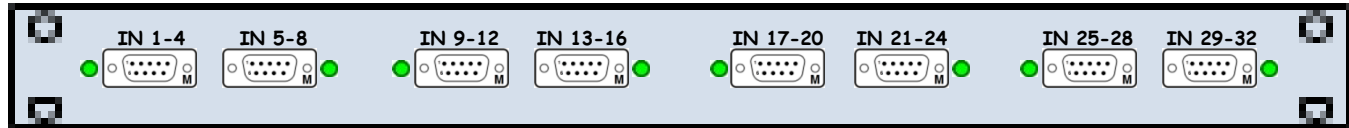

[D070081](#)

Front

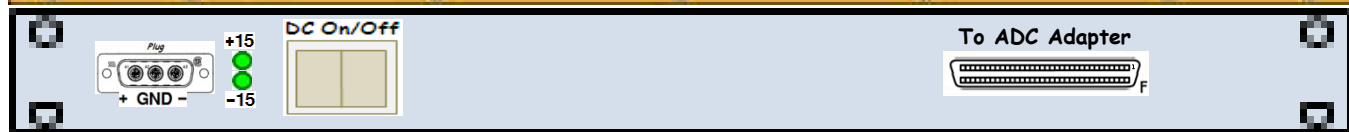
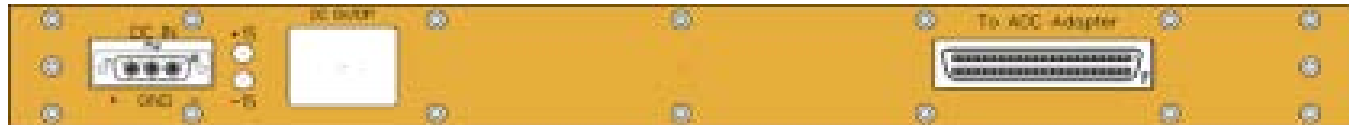
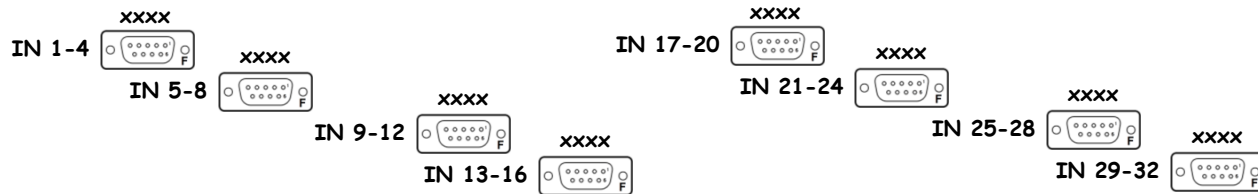

[Sxxxxxxx](#)

Rear

[TS-23](#)



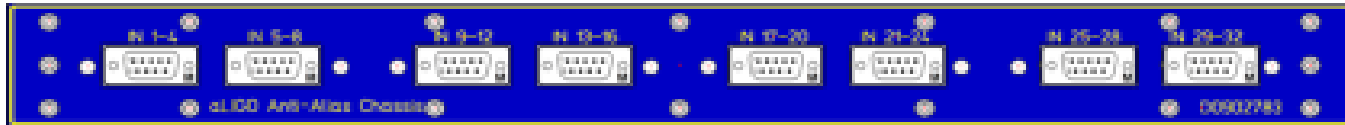

[D0902783](#)

Front

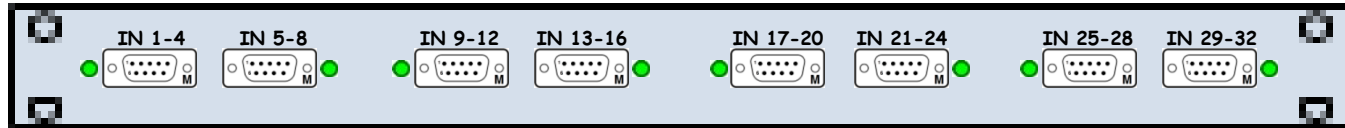

[D070081](#)

Front

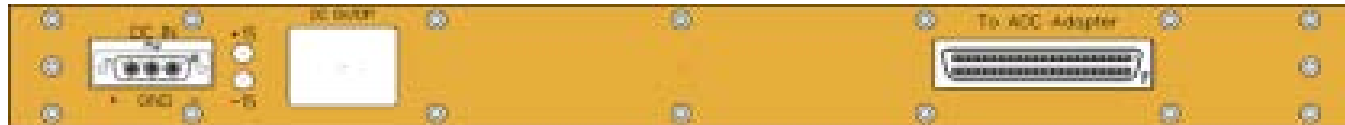
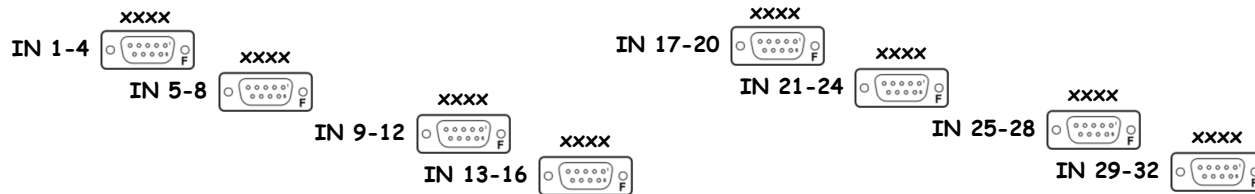

[Sxxxxxxx](#)

Rear

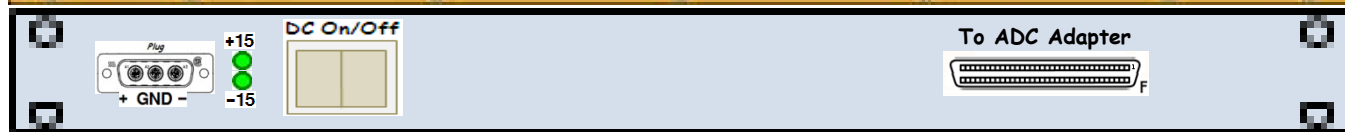

[TS-23](#)

To ADC Adapter

<< L1-ICS-C1

Anti-Alias Chassis (LSC) D0902783 Sxxxxxxx ±18@0.5A

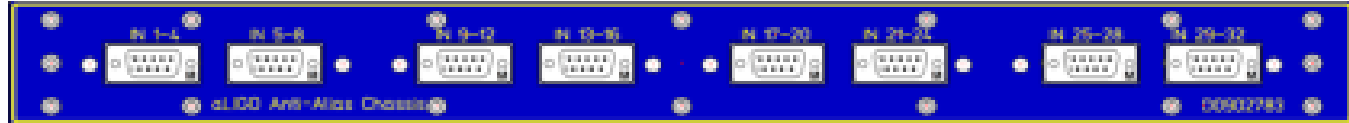

[D0902783](#)

Front

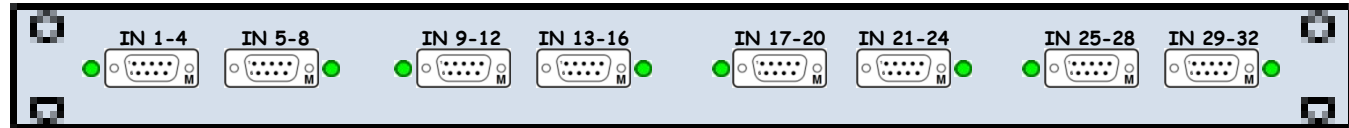

[D070081](#)

Front

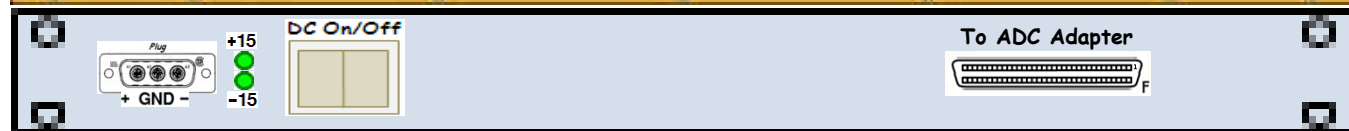
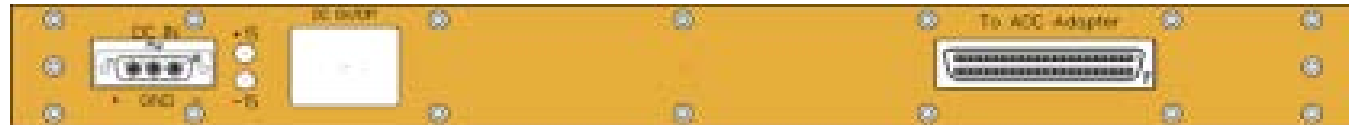
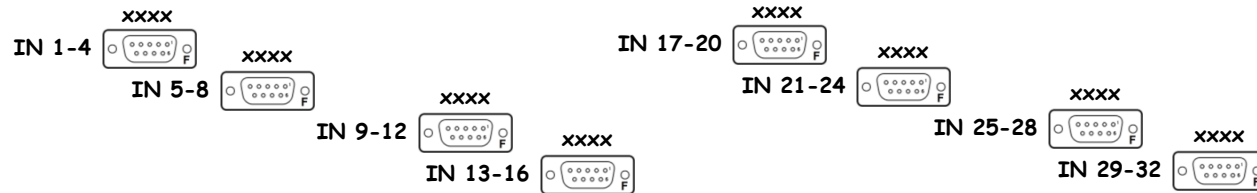

Sxxxxxxx

Rear

[TS-23](#)



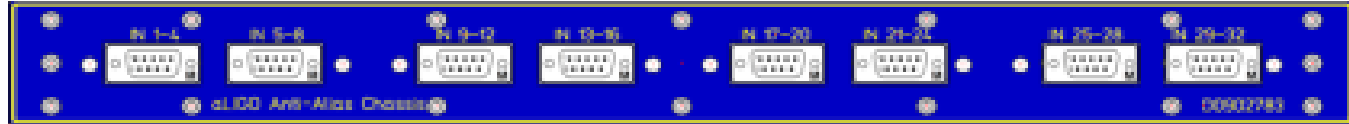

[D0902783](#)

Front

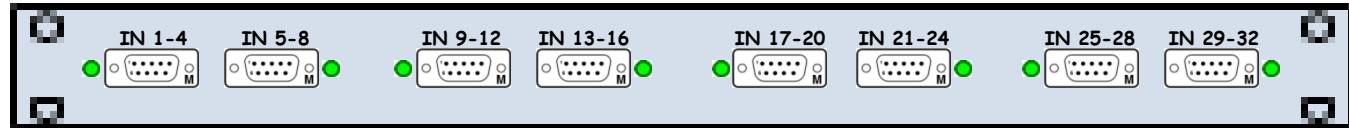

[D070081](#)

Front

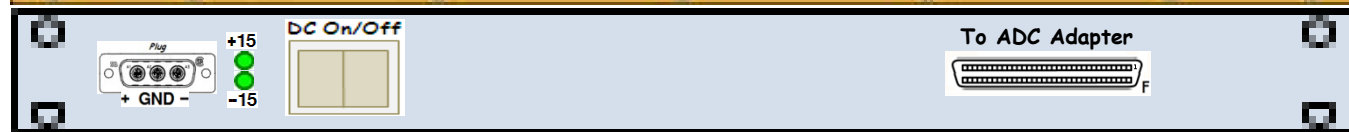
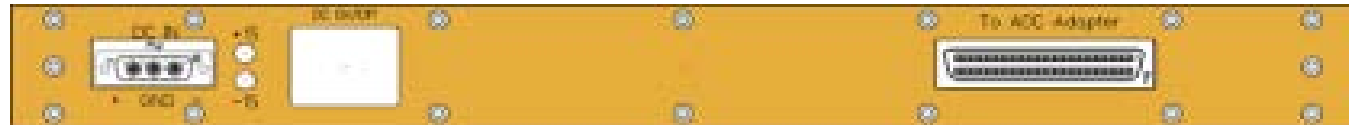
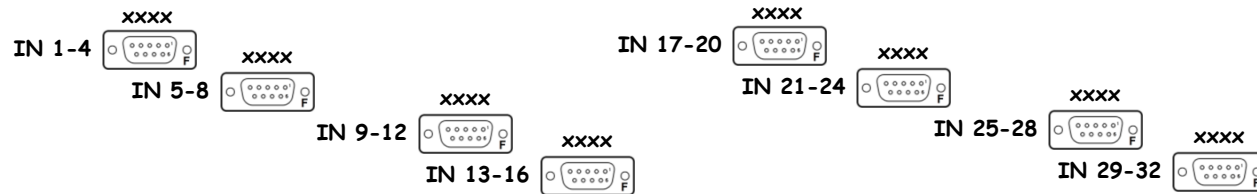

[Sxxxxxxx](#)

Rear



[TS-23](#)

To ADC Adapter

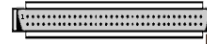

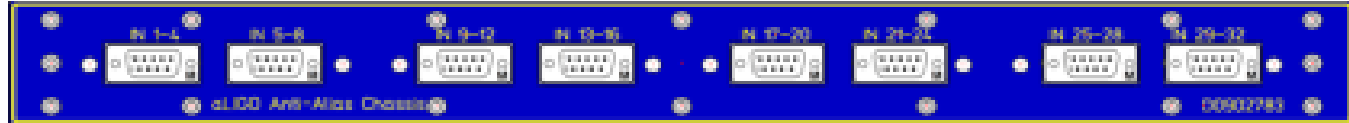

[D0902783](#)

Front

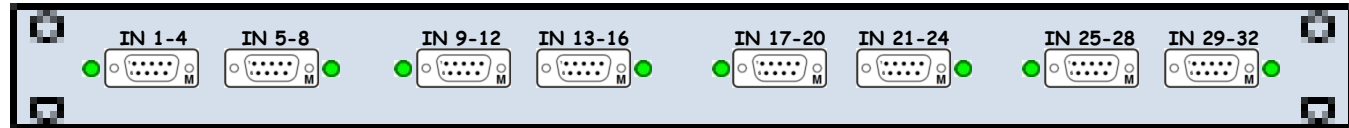

[D070081](#)

Front

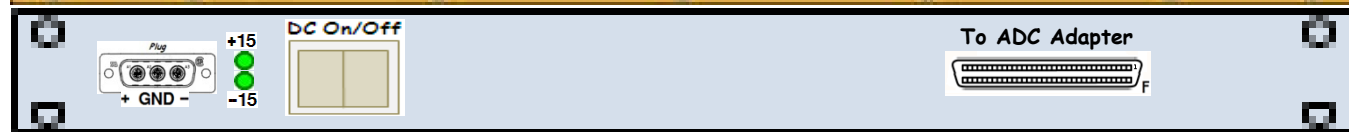
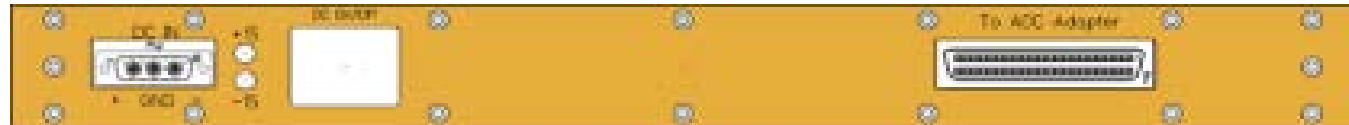
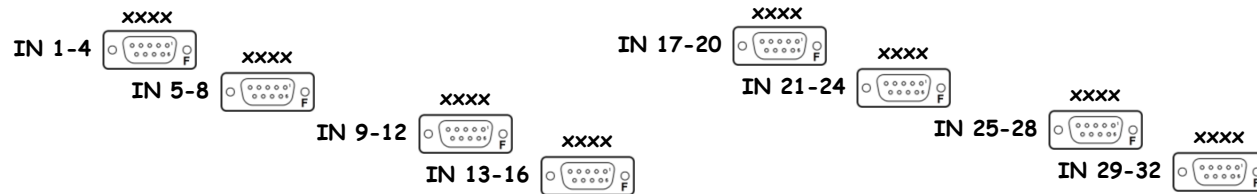

Sxxxxxxx

Rear



[TS-23](#)

To ADC Adapter

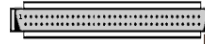

<< L1-ICS-C1

Anti-Alias Chassis (LSC) D0902783 Sxxxxxxx ±18@0.5A

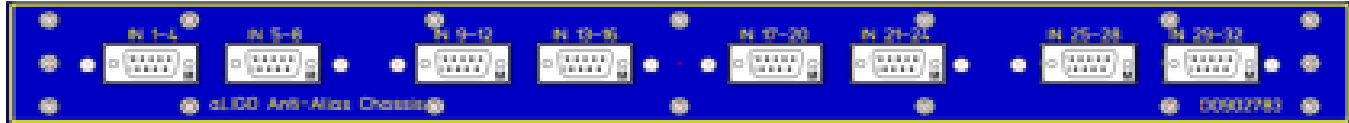

[D0902783](#)

Front

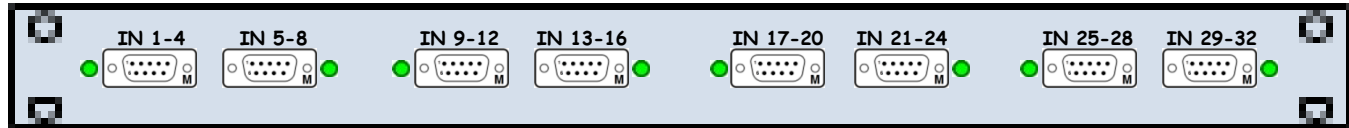

[D070081](#)

Front

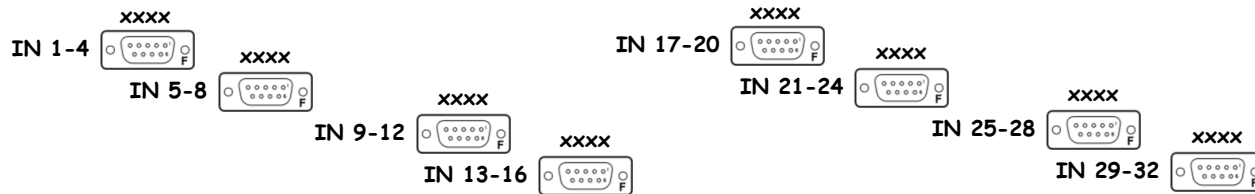

[Sxxxxxxx](#)

Rear

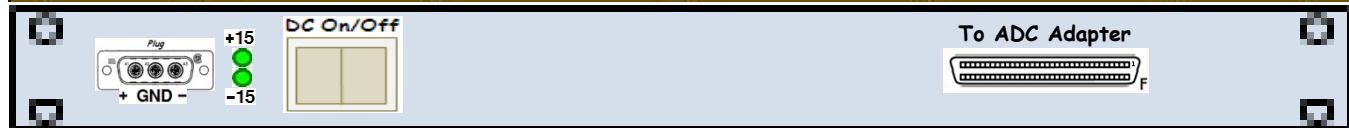

[TS-23](#)

To ADC Adapter

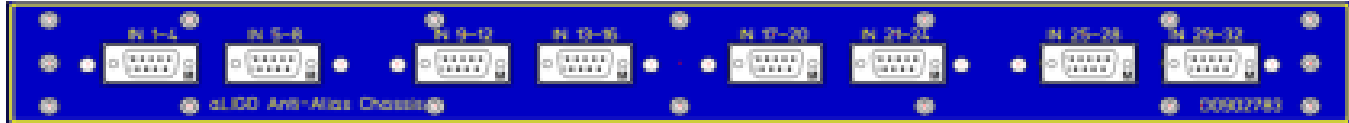

[D0902783](#)

Front

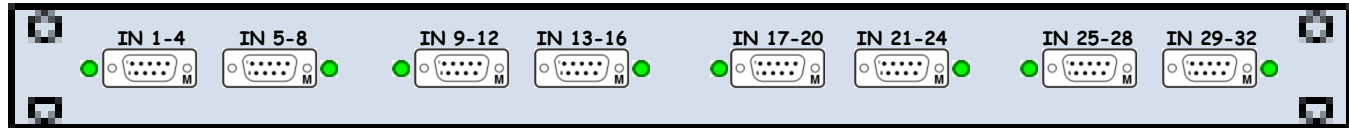

[D070081](#)

Front

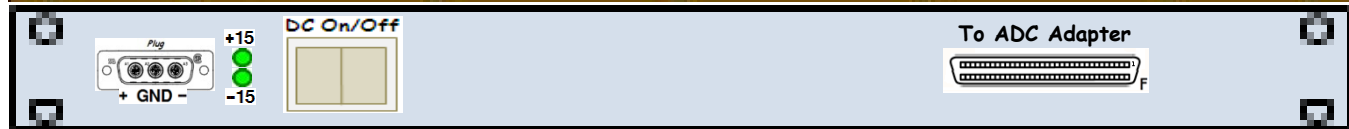
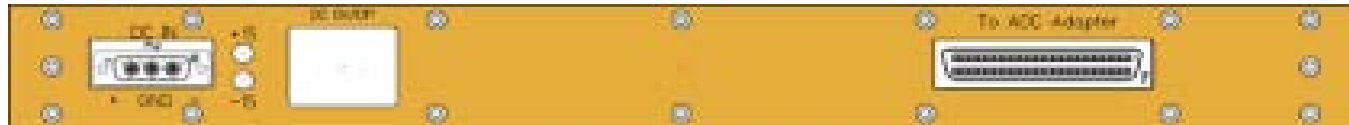
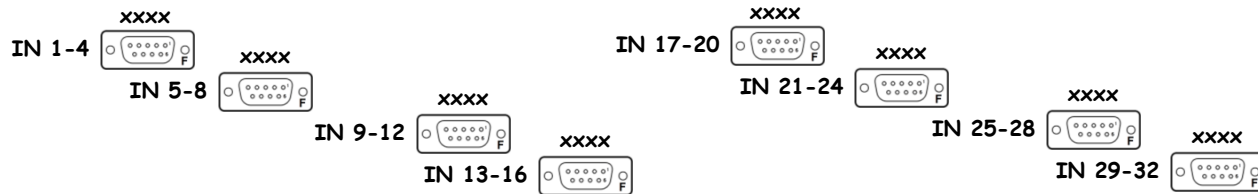

Sxxxxxxx

Rear



[TS-23](#)

To ADC Adapter

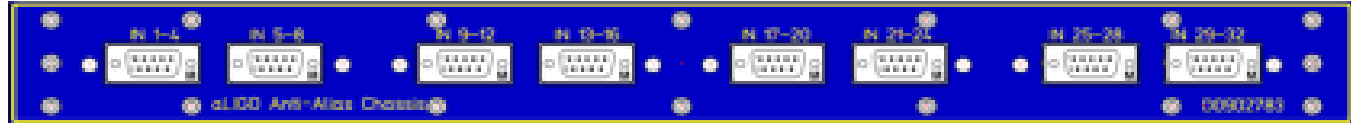

[D0902783](#)

Front

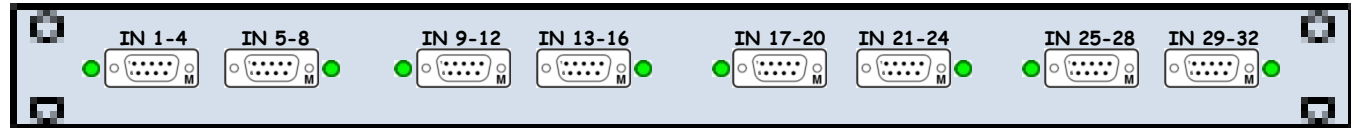

[D070081](#)

Front

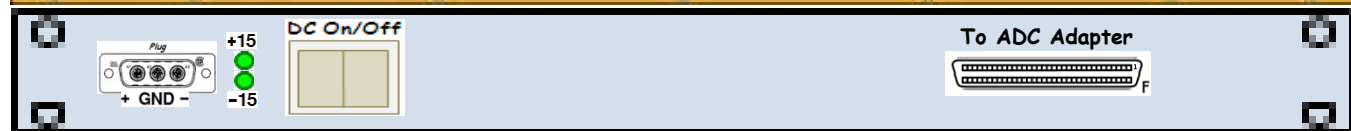
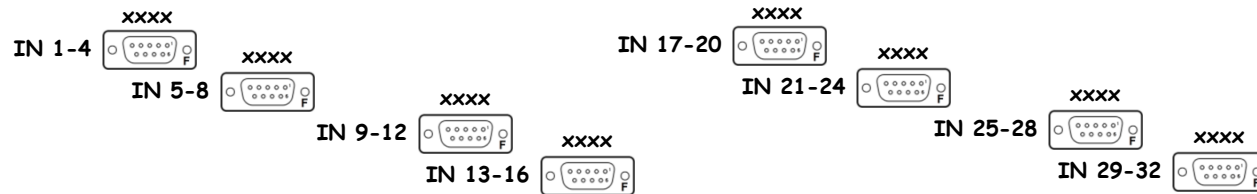

Sxxxxxxx

Rear



4-Channel Coil Driver (Tip/Tilt REFL)

D1100687

SN:

±18@0.25A

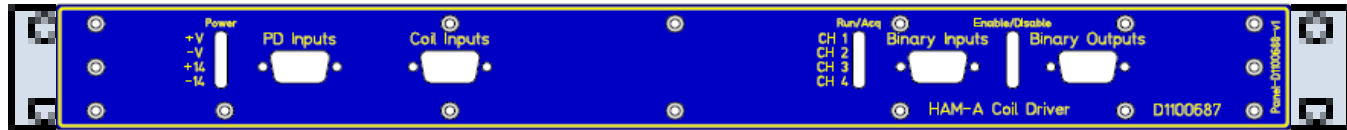

D1100688

Front



Sxxxxxxx

Rear

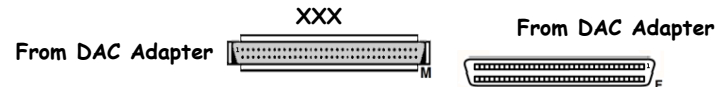

4-Channel Coil Driver (Tip/Tilt REFL)

D1100687

SN:

±18@0.25A

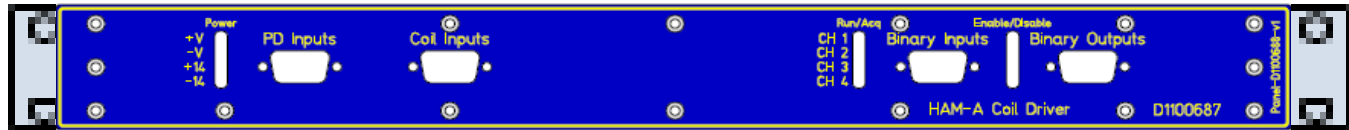

D1100688

Front



Sxxxxxxx

Rear

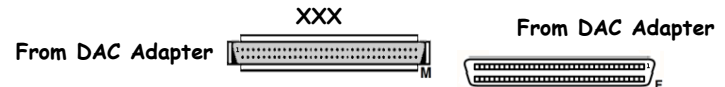

<< L1-ICS-C1

4-Channel Coil Driver (Tip/Tilt OMC)

D1100687

SN:

±18@0.25A

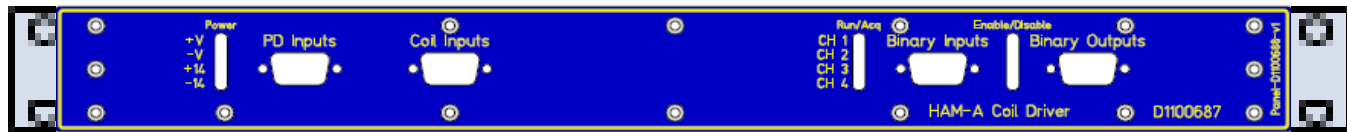

D1100688

Front



Sxxxxxxx

Rear

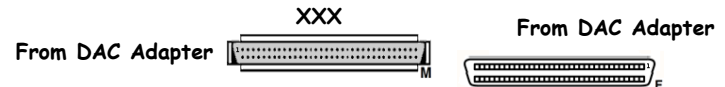

4-Channel Coil Driver (Tip/Tilt OMC)

D1100687

SN:

±18@0.25A

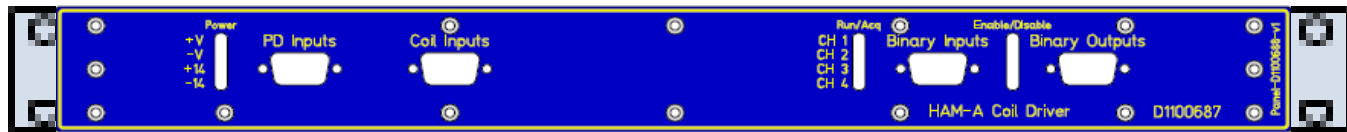

D1100688

Front



Sxxxxxxx

Rear

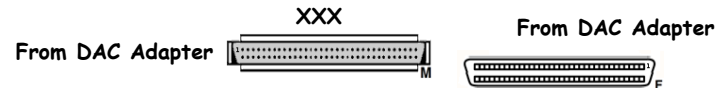

4-Channel Coil Driver (Tip/Tilt OMC)

D1100687

SN:

±18@0.25A

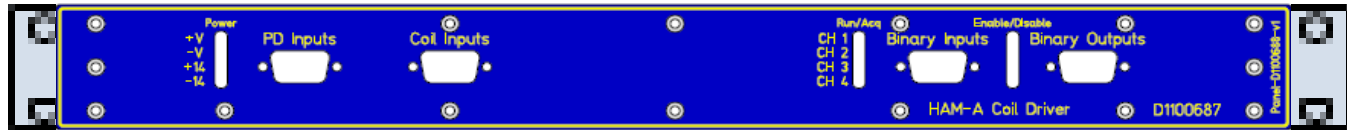

D1100688

Front



Sxxxxxxx

Rear

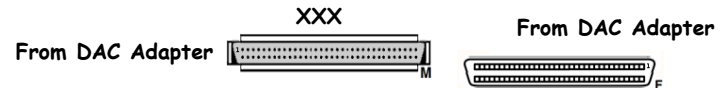

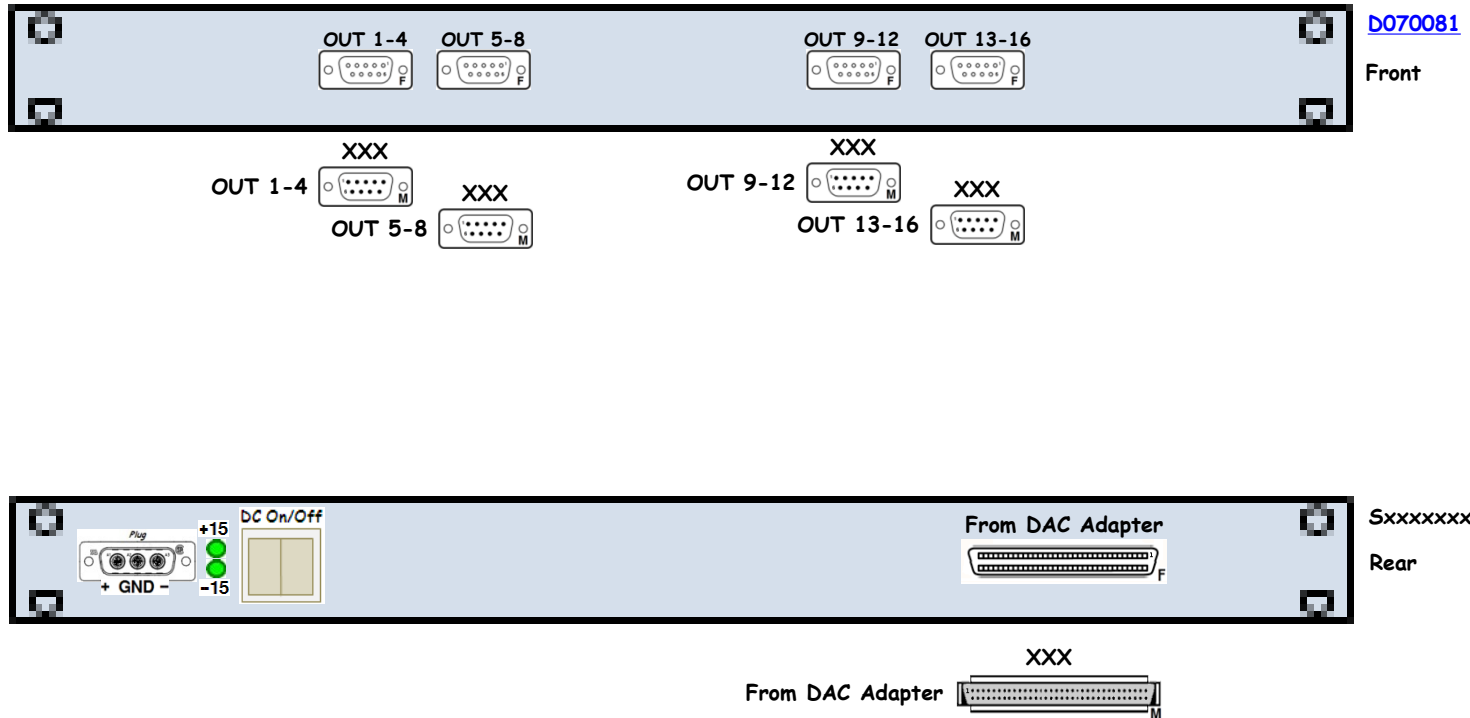

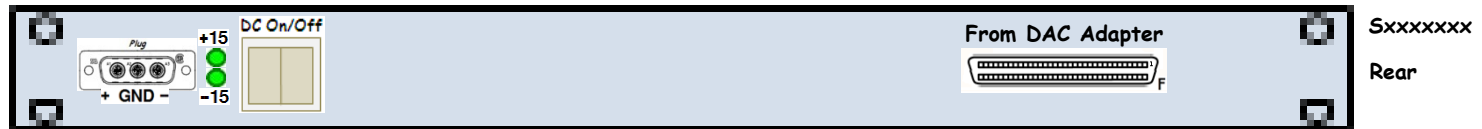

I1asc0 I/O Extension Chassis

[D1001715](#)

SN

24 VDC

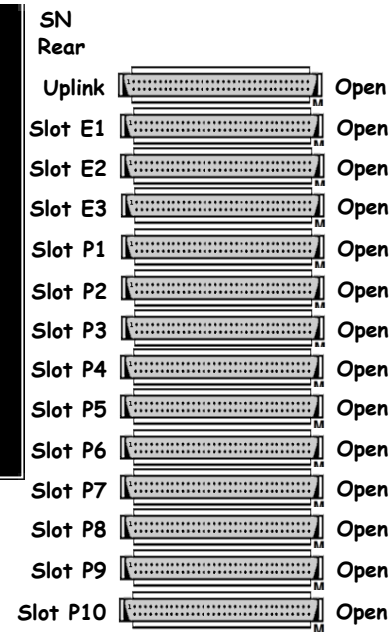
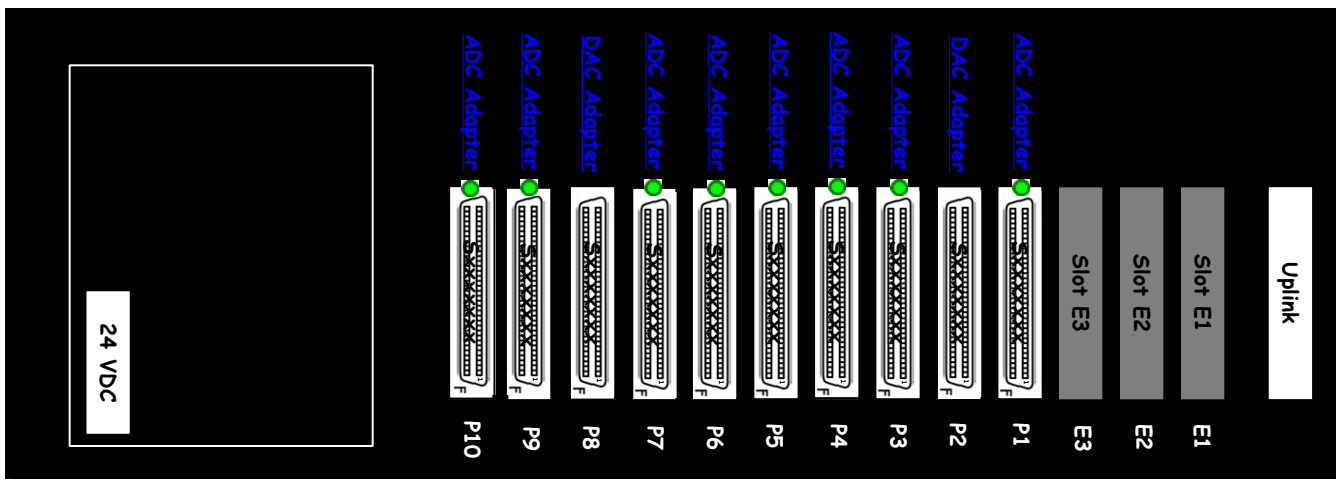
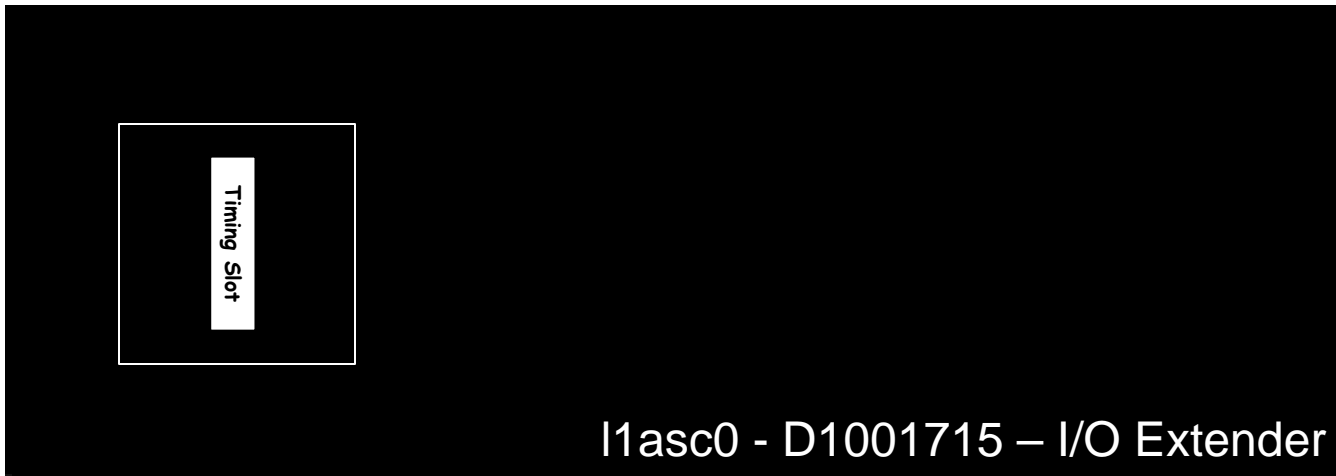

<< L1-ICS-C1

Anti-Alias Chassis (LSC) D0902783 Sxxxxxxx ±18@0.5A

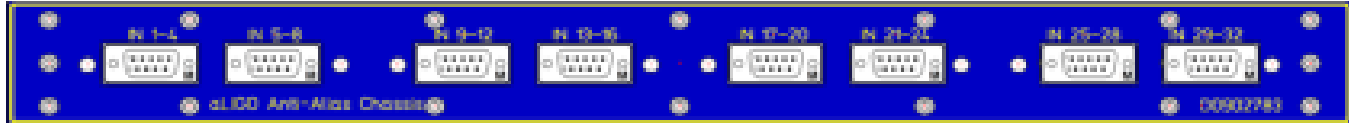

[D0902783](#)

Front

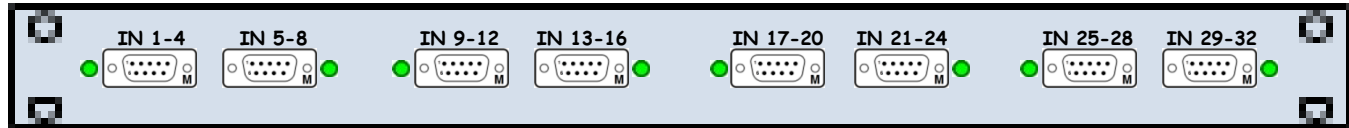

[D070081](#)

Front

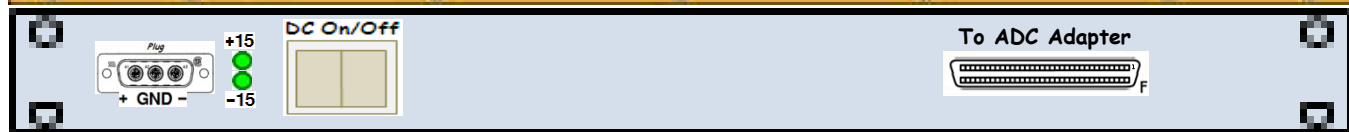
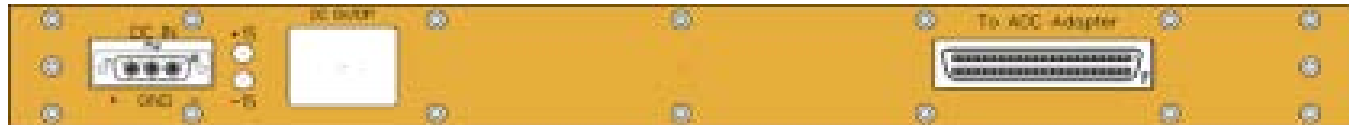
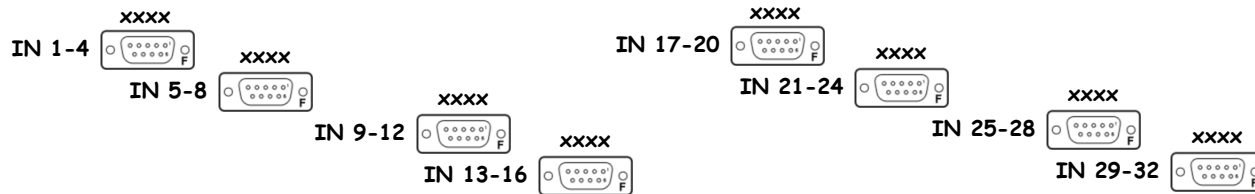

[Sxxxxxxx](#)

Rear

[TS-23](#)



<< L1-ICS-C1

Anti-Alias Chassis (LSC) D0902783 Sxxxxxxx ±18@0.5A

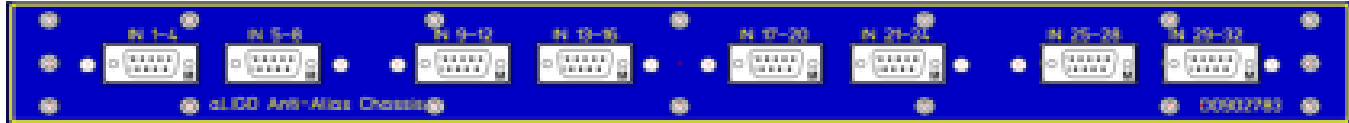

[D0902783](#)

Front

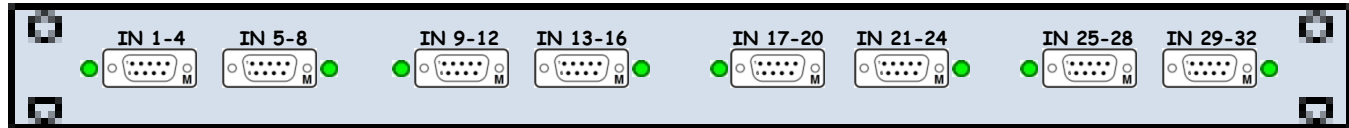

[D070081](#)

Front

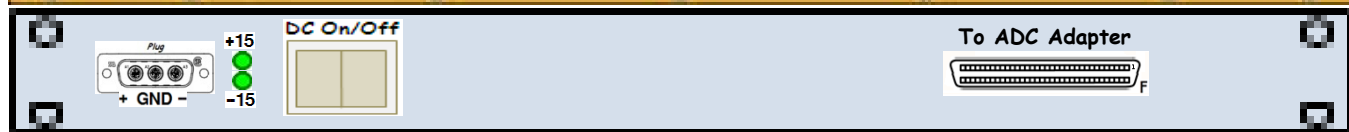
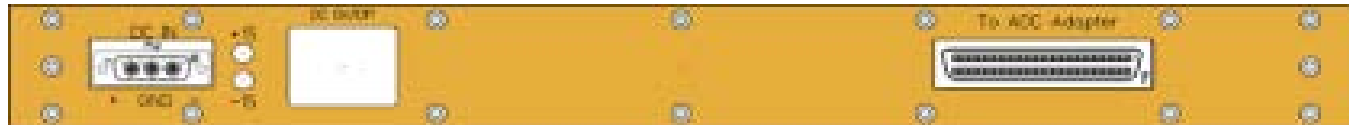
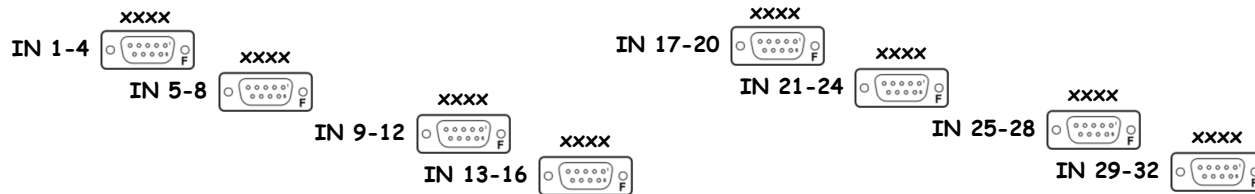

Sxxxxxxx

Rear

[TS-23](#)



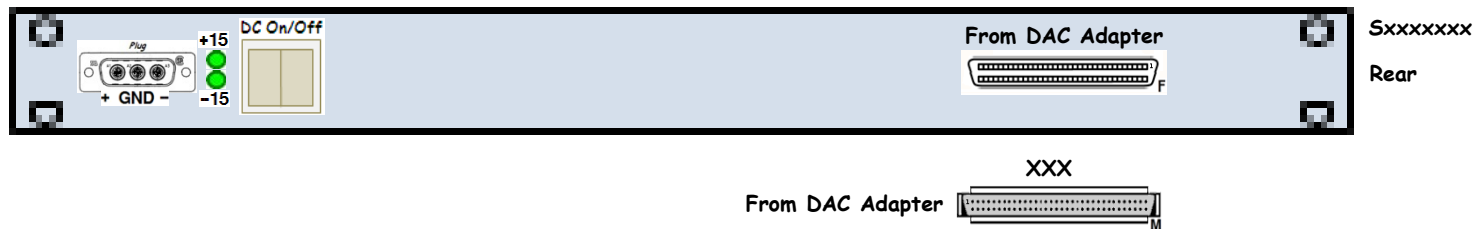
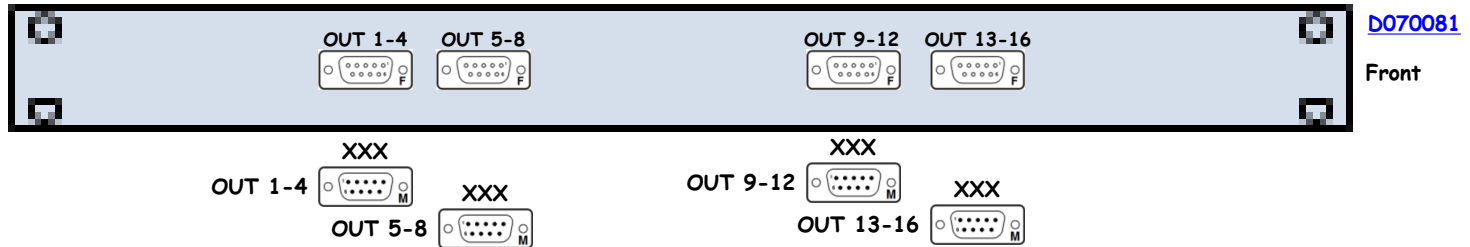



D1001715

Front

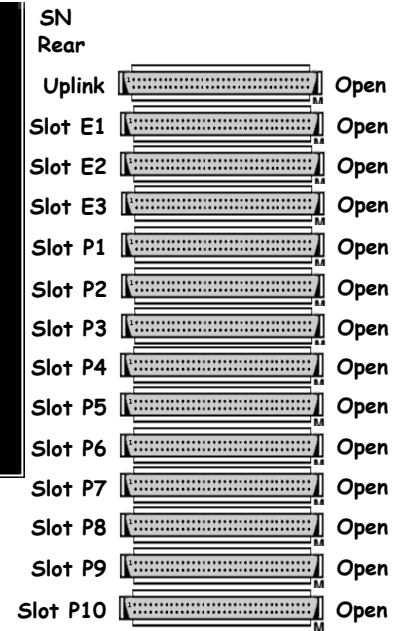
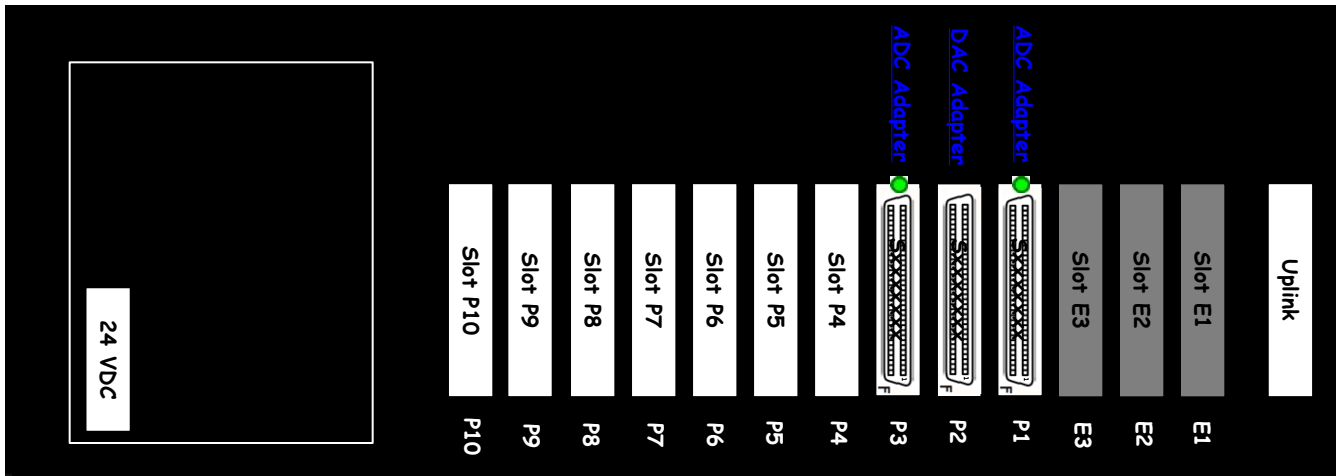

L1-ISC-C2 Details

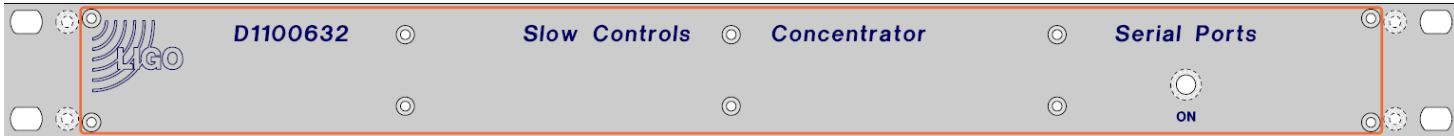

[D1100632](#)

Front

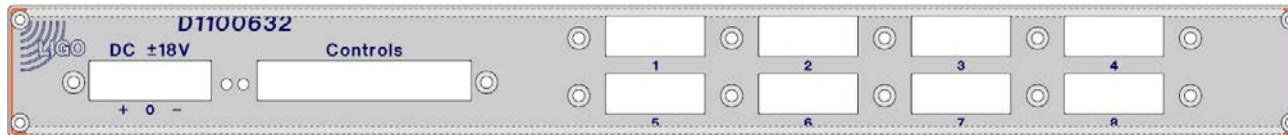

[S1001232](#)

Rear

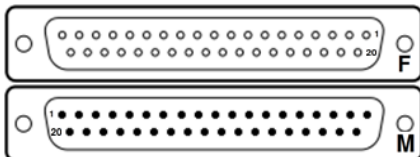

<< L1-ISC-C2

384 Channel Binary Output (R1 & R2 Whitening)

D1100251

SN:

+24VDC

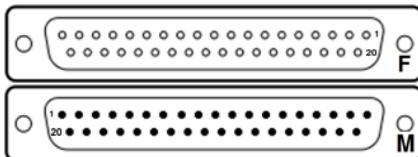
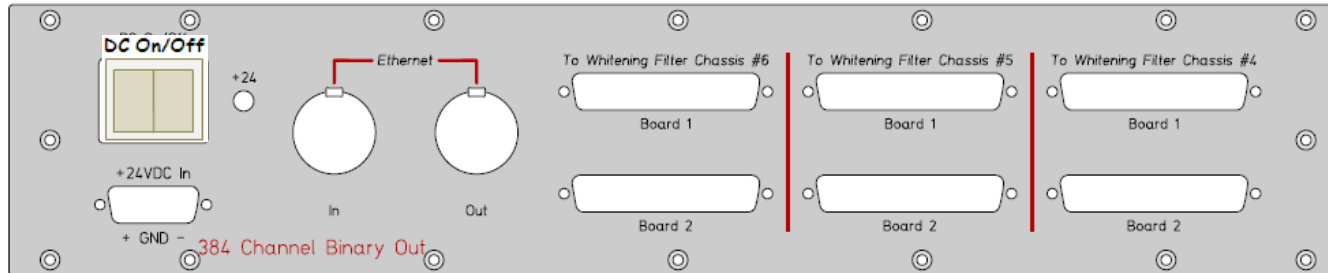
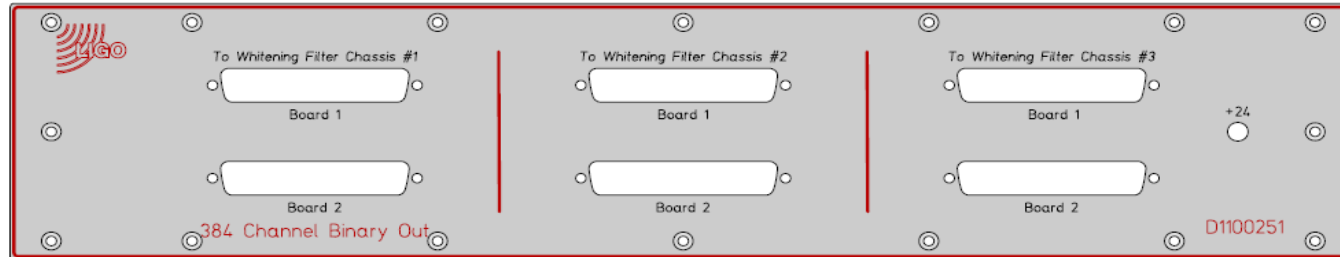

<< L1-ISC-C2

384 Channel Binary Output (R2 & R4 Whitening)

D1100251

SN:

+24VDC

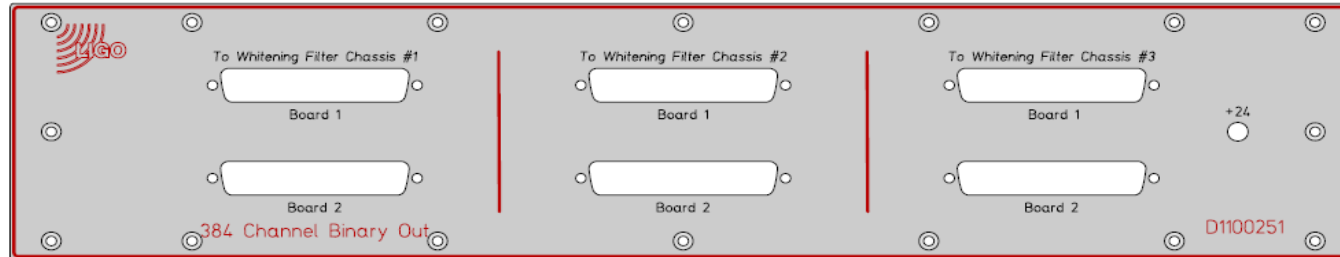

D1100251

Front

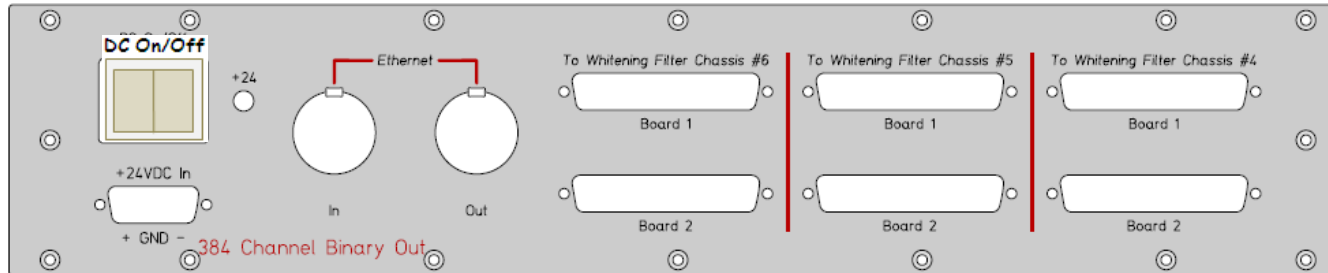

S1001232

Rear

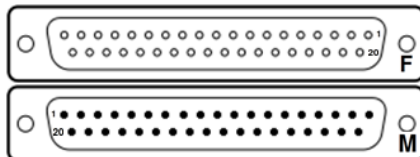

<< L1-ISC-C2

384 Channel Binary Output (R5 & R6 Whitening)

D1100251

SN:

+24VDC

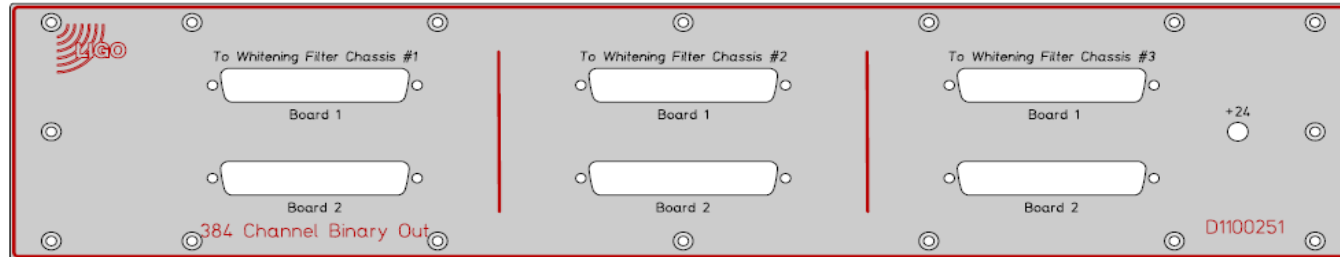

D1100251

Front

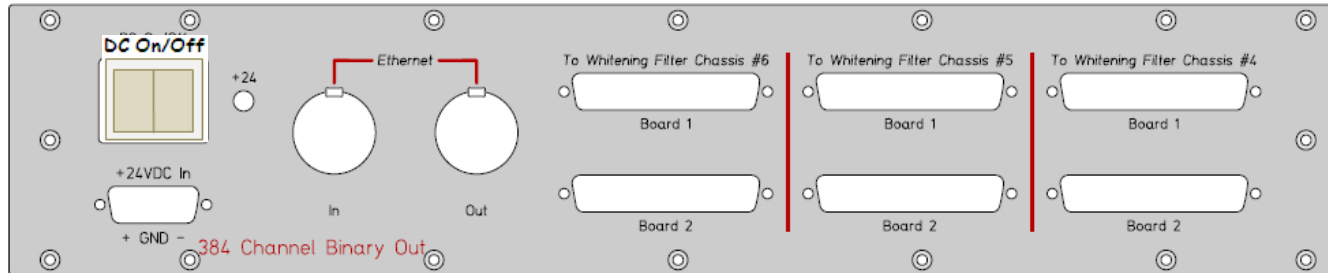

S1001232

Rear

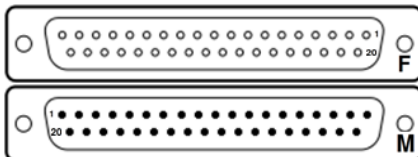

<< L1-ISC-C2

384 Channel Binary Output (R6 Whitening)

D1100251

SN:

+24VDC

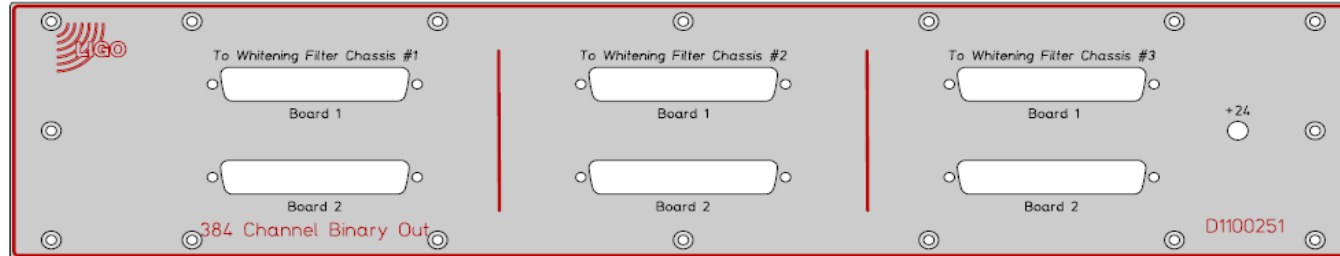

D1100251

Front

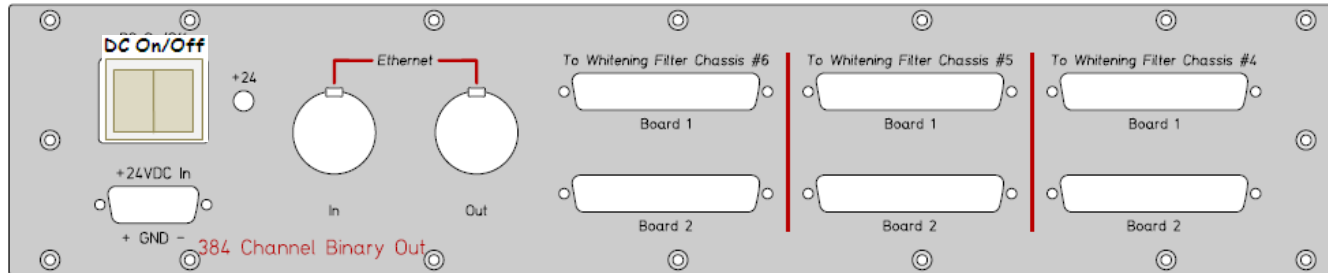

S1001232

Rear

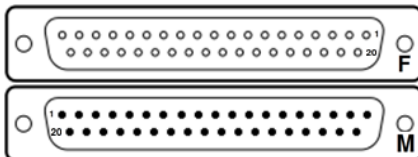

<< [L1-ISC-C2](#)

Beckhoff Concentrator 1 (CM Servo, VCO, Delay Line)

[D1102961](#)

SN:

Power

[D1102961](#)

Front

[S1001232](#)

Rear

DC On/Off

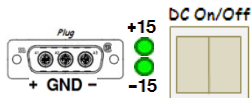

From DAC Adapter

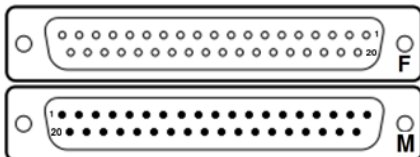

D1100680 - Sxxxxxxx

LIGO

<< [L1-ISC-C2](#)

Beckhoff Concentrator 2 (Picomotor, Serial Ports, Modbus)

[D1100680](#)

SN:

Power

[D1100680](#)

Front

[S1001232](#)

Rear

DC On/Off

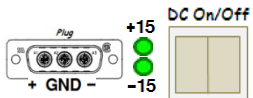

From DAC Adapter

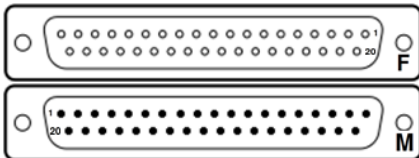

<< [L1-ISC-C2](#)

Beckhoff Concentrator 3 (LSC Demod, VCO, Delay Line, RF Amps)

[D1100681](#)

SN:

Power

[D1100681](#)

Front

[S1001232](#)

Rear

DC On/Off

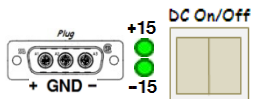

From DAC Adapter

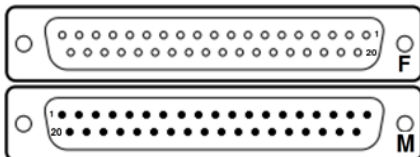
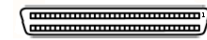

<< [L1-ISC-C2](#)

Beckhoff Concentrator 4 (ASC Demod)

[D1101266](#)

SN:

Power

[D1101266](#)

Front

[S1001232](#)

Rear

DC On/Off

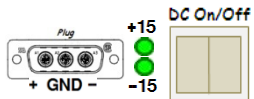

From DAC Adapter

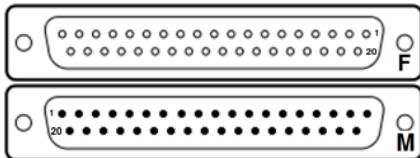

<< [L1-ISC-C2](#)

Beckhoff Concentrator 5 (Beam Diverters, Shutters, Aux Channels)

[D1200132](#)

SN:

Power

[D1200132](#)

Front

[S1001232](#)

Rear

DC On/Off

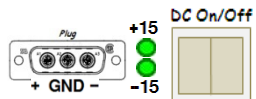

From DAC Adapter

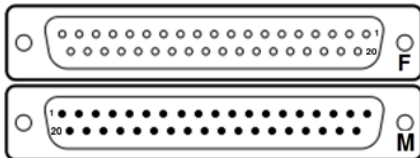

L1-ISC-C3 Details

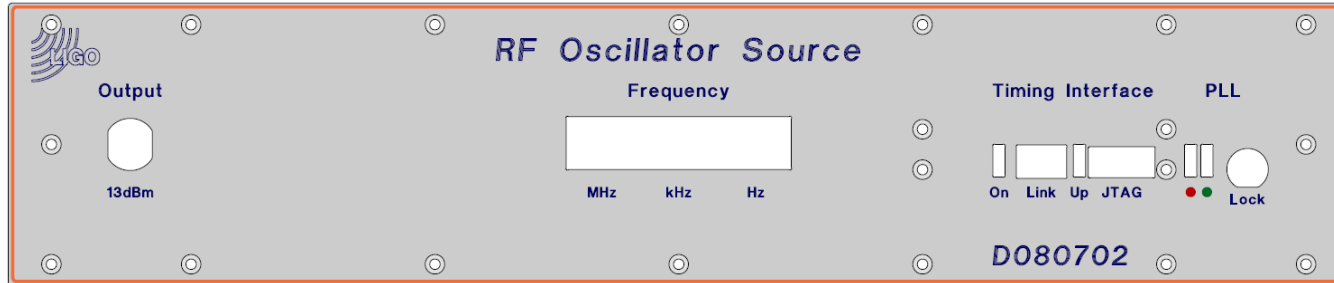

[D080702](#)

Front

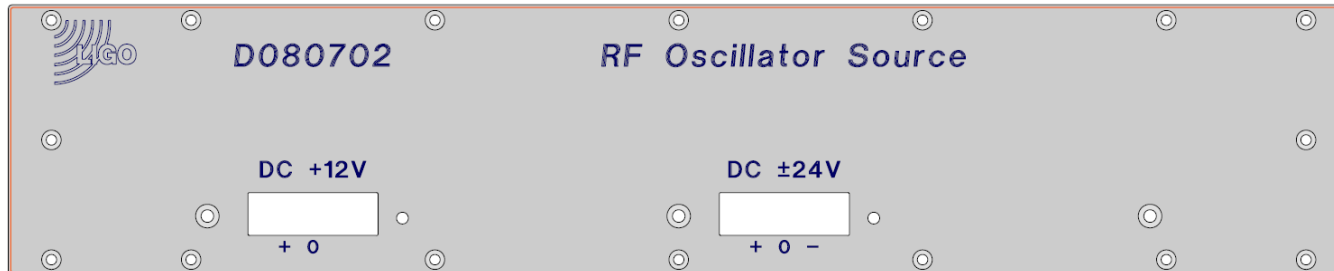

[S1001232](#)

Rear

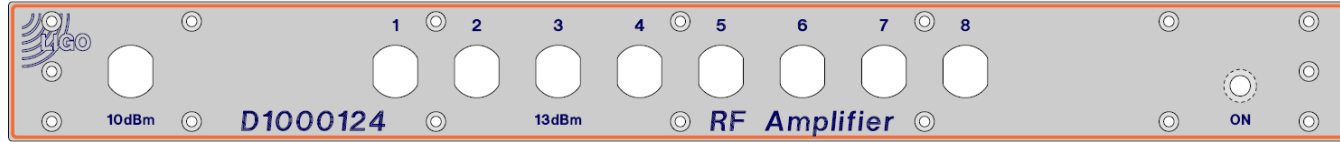

[D1000124](#)

Front

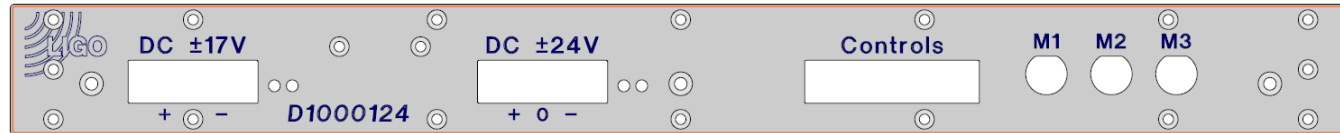

[S1001232](#)

Rear

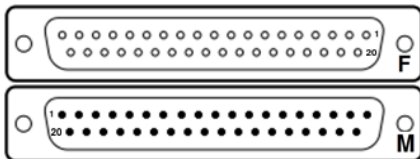

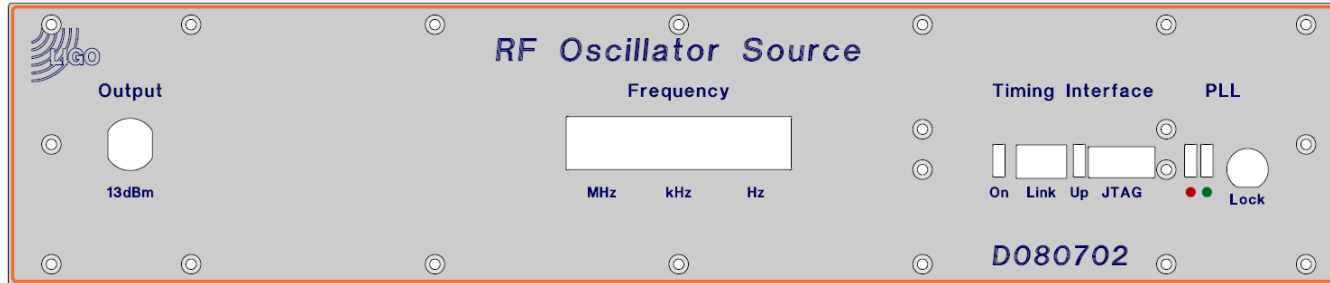

[D080702](#)

Front

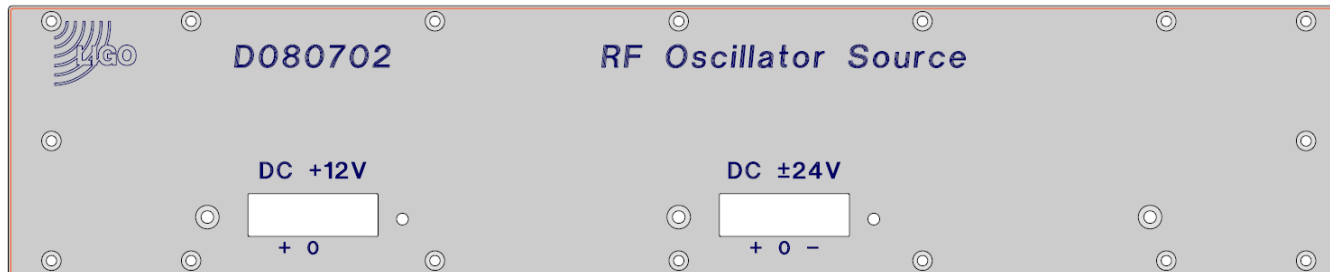

[S1001232](#)

Rear

D1000124 - Sxxxxxxx

<< L1-ISC-C3

35.5 MHz Distribution Amplifier D1000124 Sxxxxxxx ±17VDC, ±24VDC

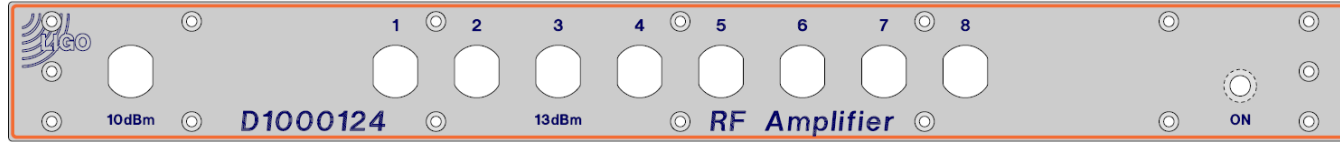

[D1000124](#)

Front

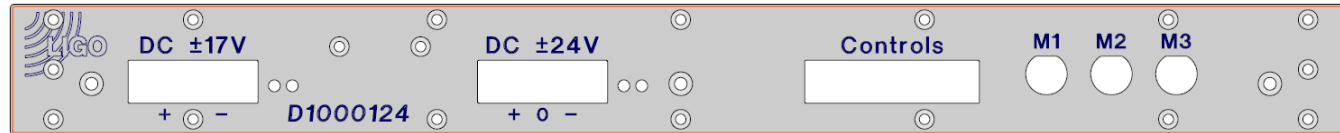

[S1001232](#)

Rear

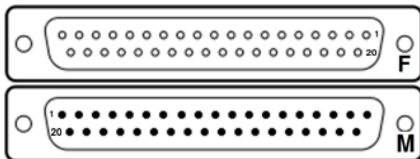

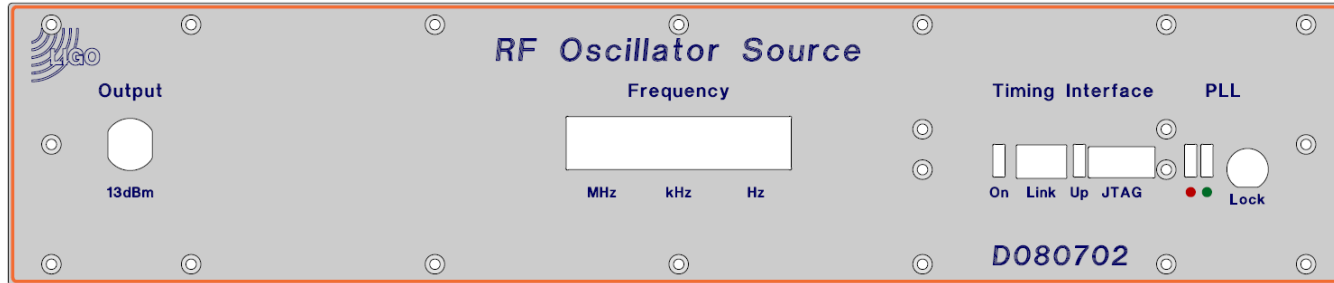

[D080702](#)

Front

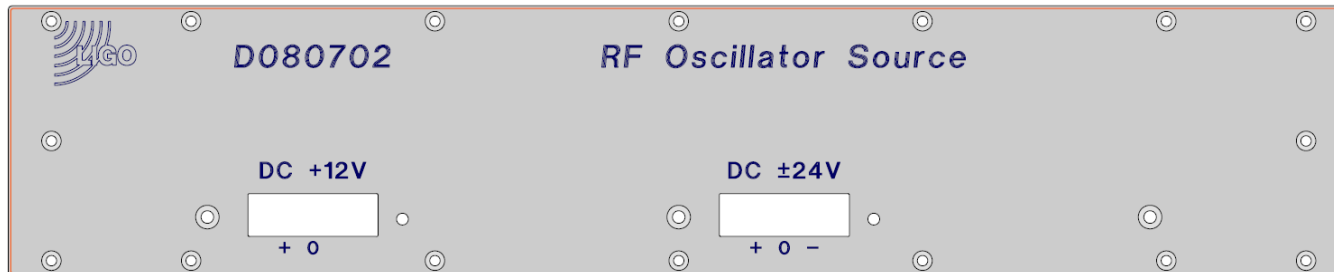

[S1001232](#)

Rear

D1000124 - Sxxxxxxx

<< L1-ISC-C3

80 MHz Distribution Amplifier D1000124 Sxxxxxxx ±17VDC, ±24VDC

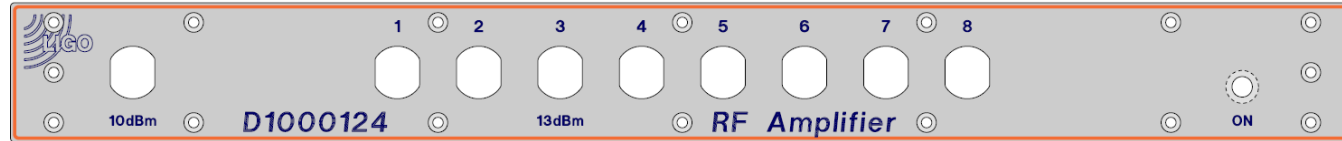

[D1000124](#)

Front

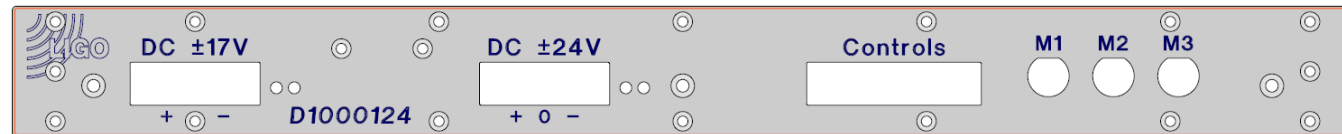

[S1001232](#)

Rear

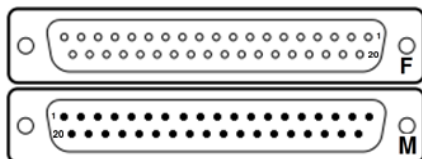

D1002182 - Sxxxxxxx

<< L1-ISC-C3

40 MHz Frequency Divider ±17VDC, ±24VDC

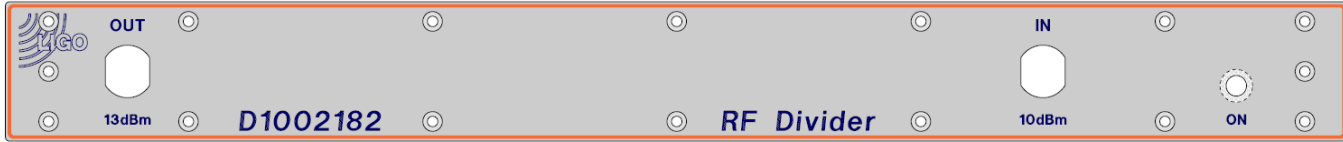

[D1002182](#)

Front

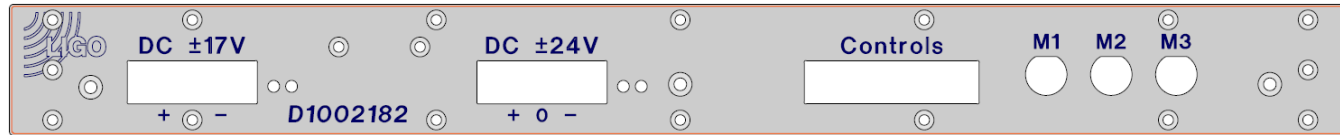

[S1001232](#)

Rear

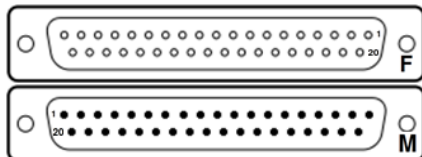

D1000124 - Sxxxxxxx

<< [L1-ISC-C3](#)

40 MHz Distribution Amplifier ±17VDC, ±24VDC

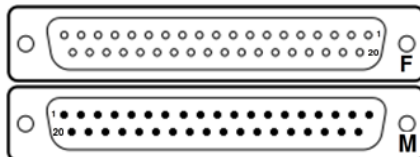
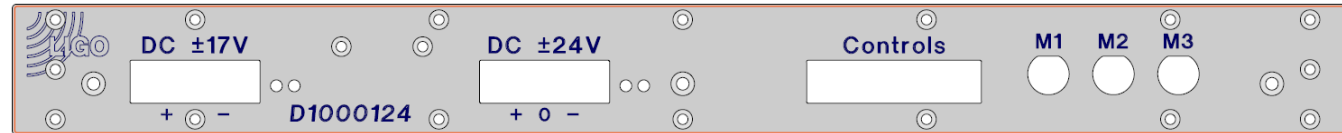
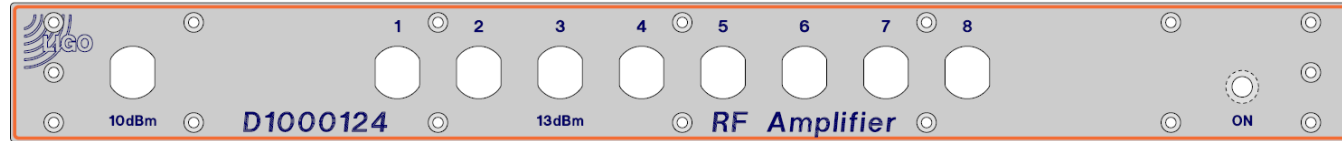

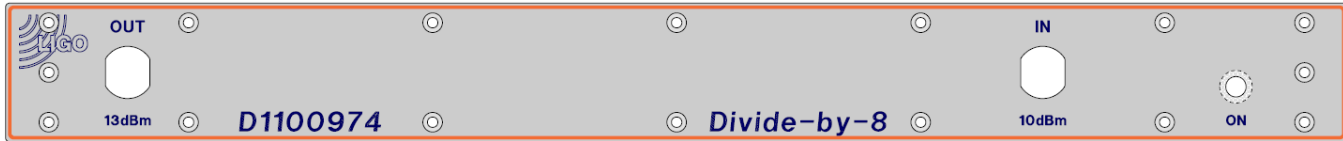

[D1100974](#)

Front

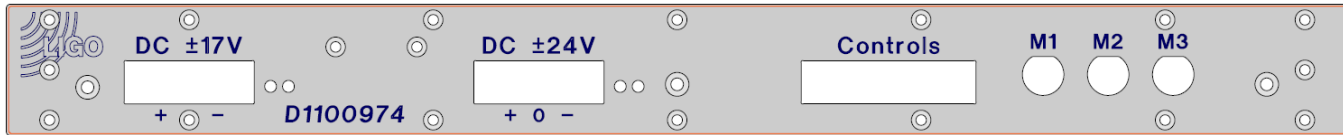

[S1001232](#)

Rear

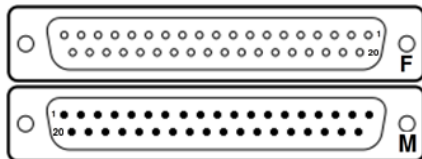

D1000124 - Sxxxxxxx

<< L1-ISC-C3

10 MHz Distribution Amplifier D1000124 Sxxxxxxx ±17VDC, ±24VDC

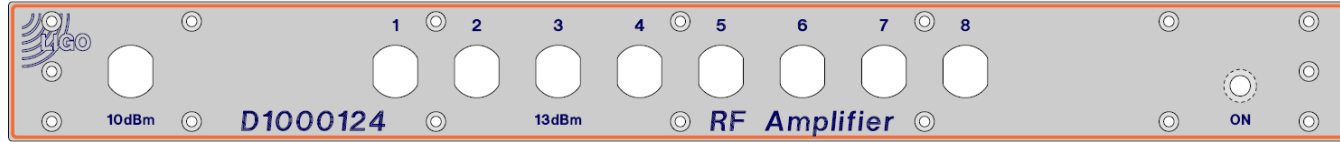

[D1000124](#)

Front

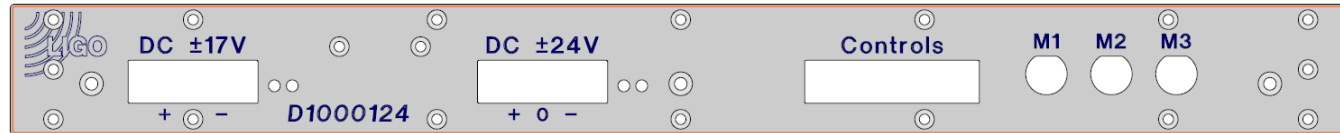

[S1001232](#)

Rear

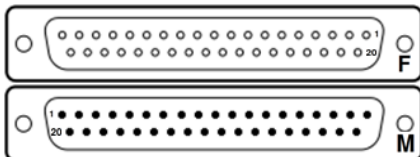

<< L1-ISC-C3

RF Amplifier Concentrator 1

D1100262

SN:

±18VDC



D1100262

Front

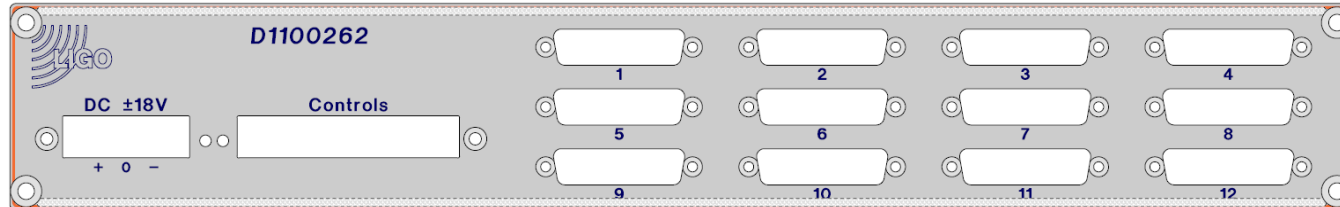

S1001232

Rear

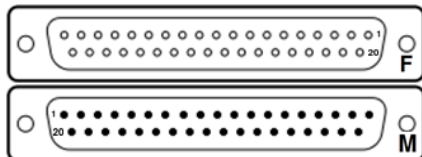

<< L1-ISC-C3

RF Amplifier Concentrator 2

D1100262

SN:

±18VDC



D1100262

Front

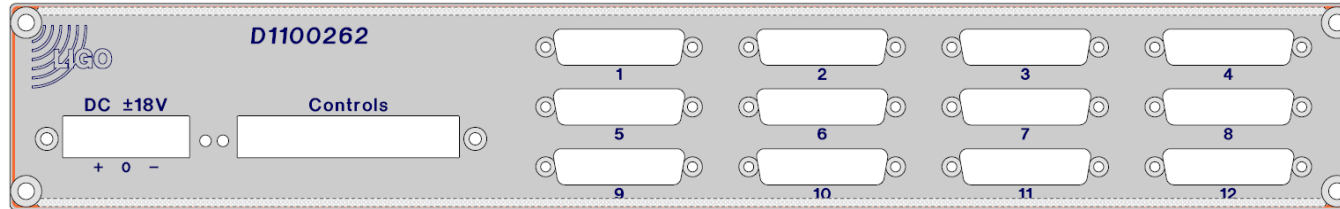

S1001232

Rear

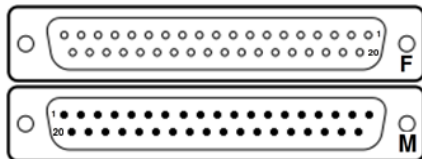

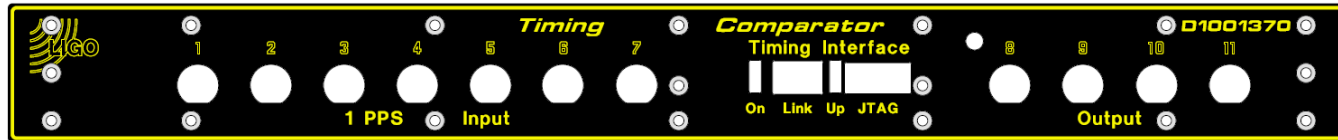

[D1001370](#)

Front



[S1001232](#)

Rear

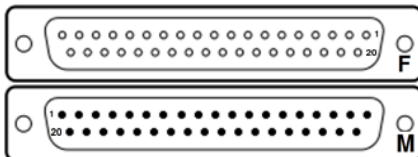

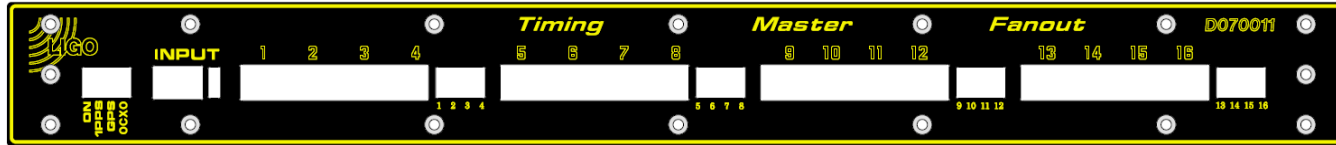

[D080534](#)

D070011

Front

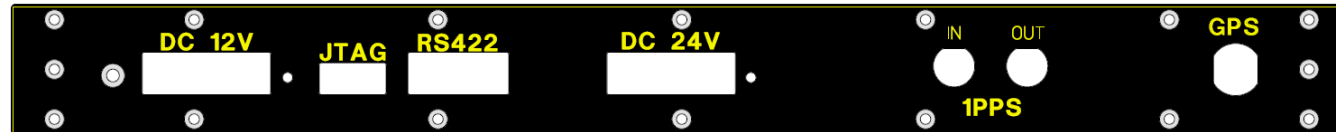

Master

[S1001232](#)

Rear

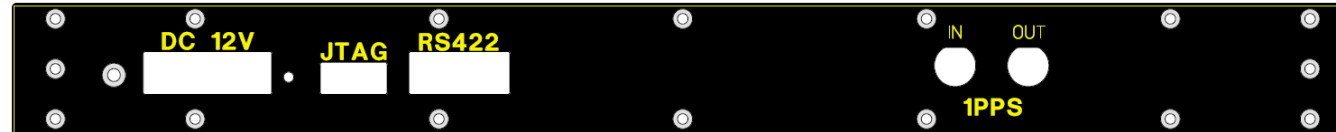

Fanout

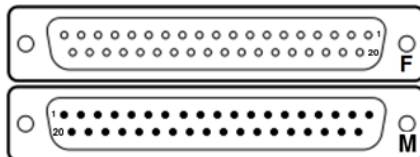

L1-ISC-C4 Details

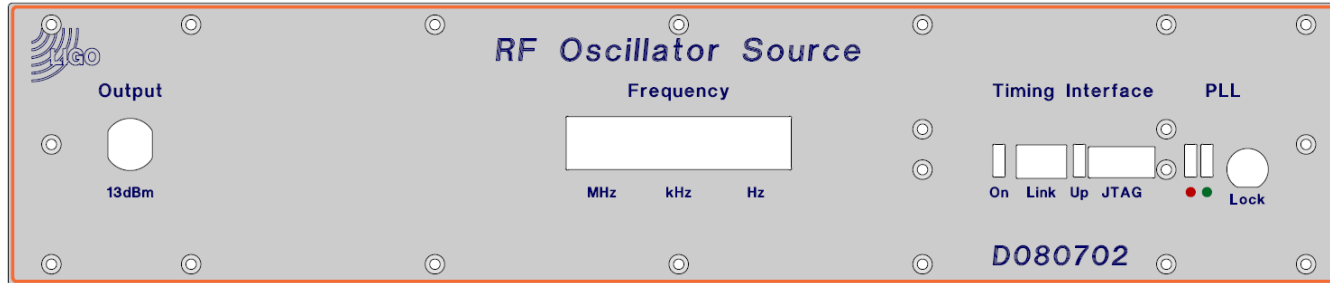

[D080702](#)

Front

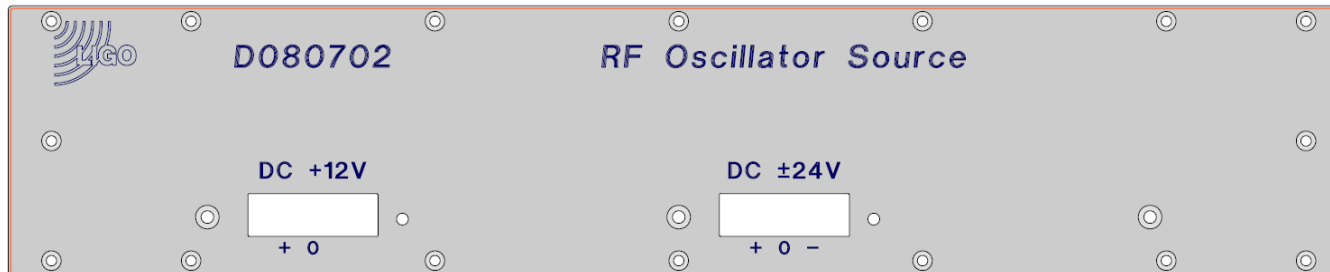

[S1001232](#)

Rear

D1000124 - Sxxxxxxx

<< [L1-ISC-C4](#)

9.099 / 8.684 MHz Distribution Amplifier

±17VDC, ±24VDC

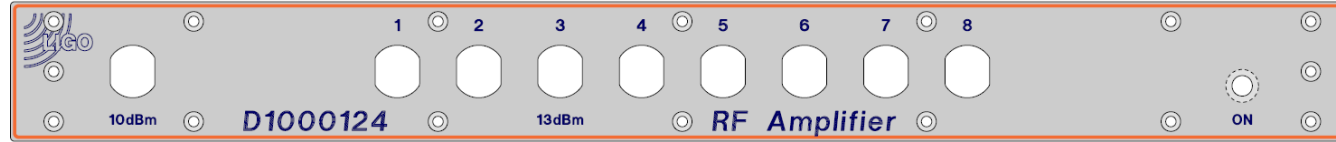

[D1000124](#)

Front

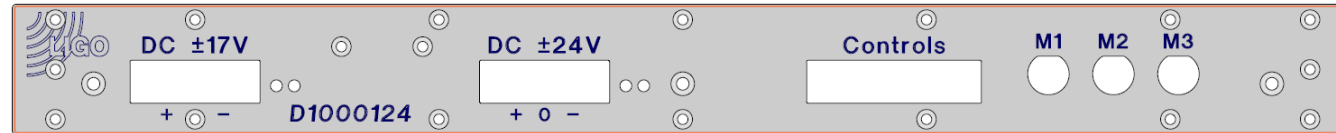

[S1001232](#)

Rear

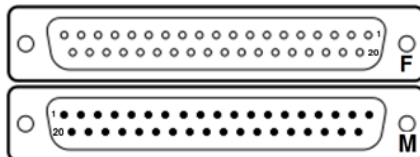

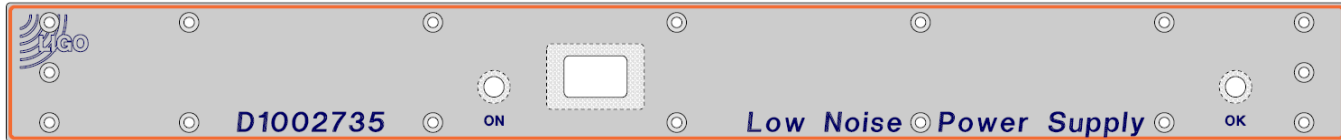

[D1002735](#)

Front

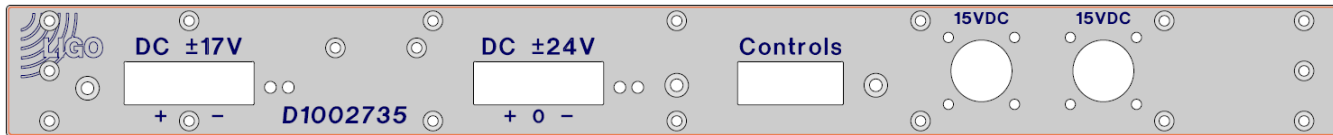

[Sxxxxxxx](#)

Rear

From DAC Adapter

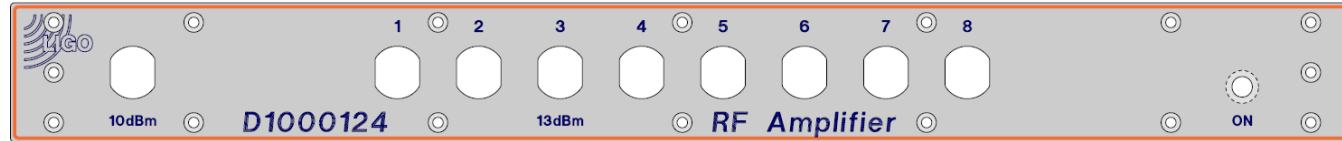

[D1000124](#)

Front

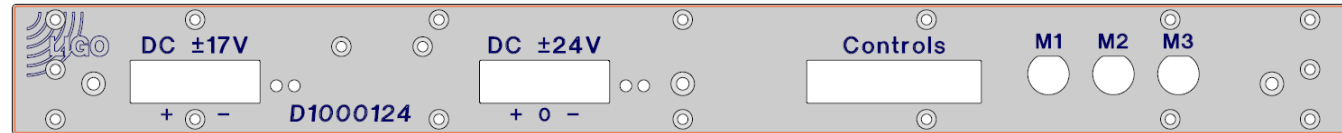

[S1001232](#)

Rear

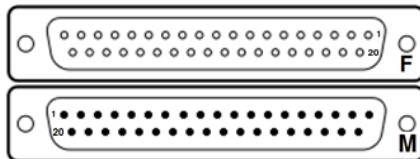

D1000124 - Sxxxxxxx

<< [L1-ISC-C4](#)

27 MHz Distribution Amplifier ±17VDC, ±24VDC

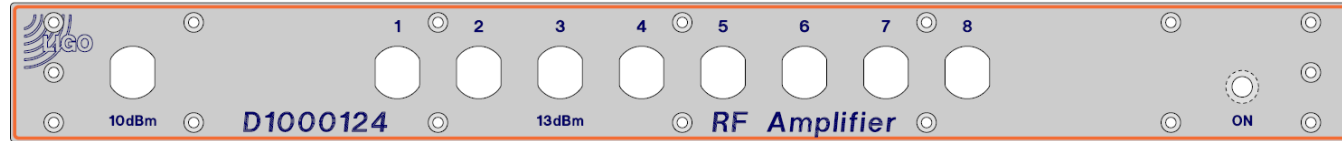

[D1000124](#)

Front

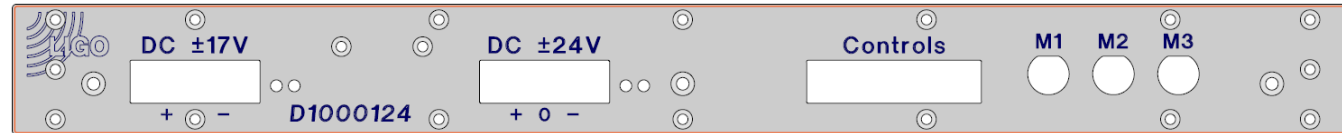

[S1001232](#)

Rear

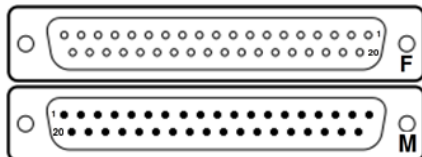

D1000124 - Sxxxxxxx

<< [L1-ISC-C4](#)

36 MHz Distribution Amplifier

±17VDC, ±24VDC

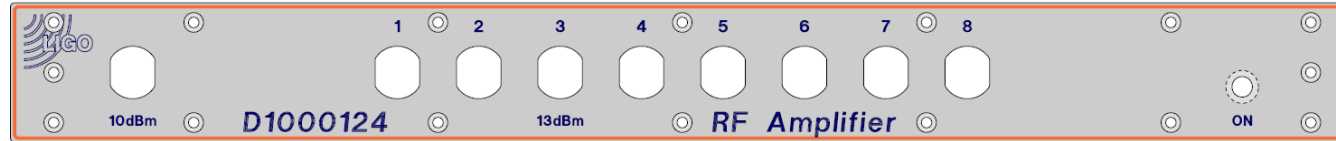

[D1000124](#)

Front

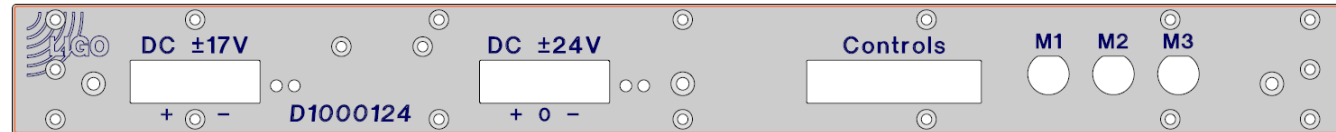

[S1001232](#)

Rear

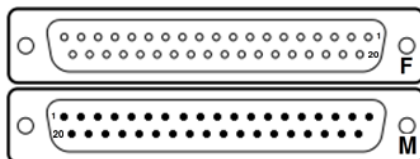

D1000124 - Sxxxxxxx

<< [L1-ISC-C4](#)

45 MHz Distribution Amplifier $\pm 17\text{VDC}$, $\pm 24\text{VDC}$

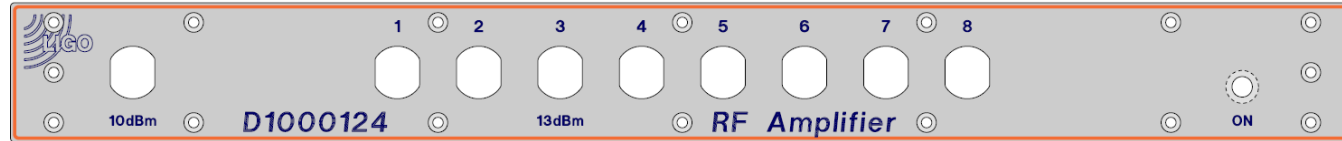

[D1000124](#)

Front

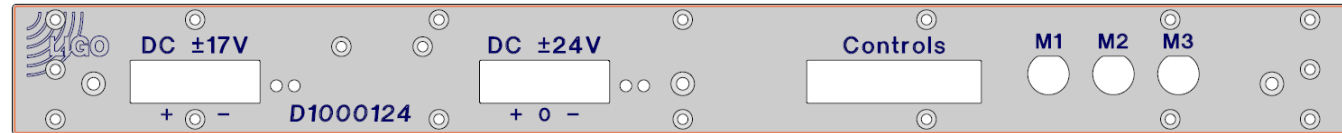

[S1001232](#)

Rear

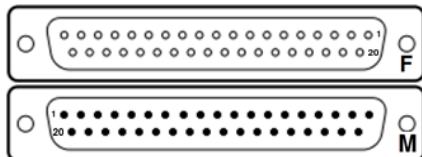

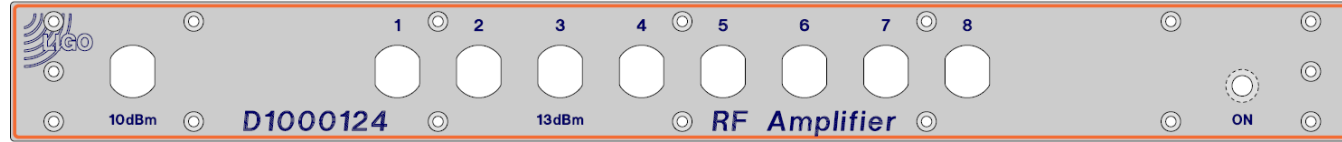

[D1000124](#)

Front

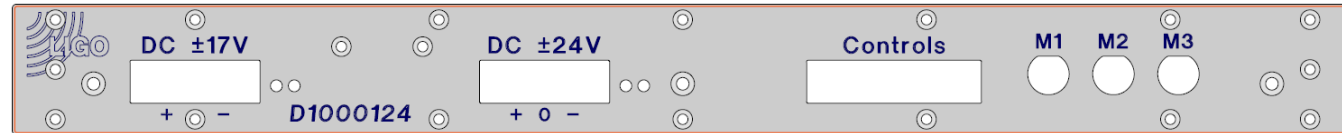

[S1001232](#)

Rear

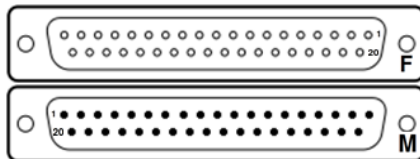

D1000124 - Sxxxxxxx

<< [L1-ISC-C4](#)

135 MHz Distribution Amplifier ±17VDC, ±24VDC

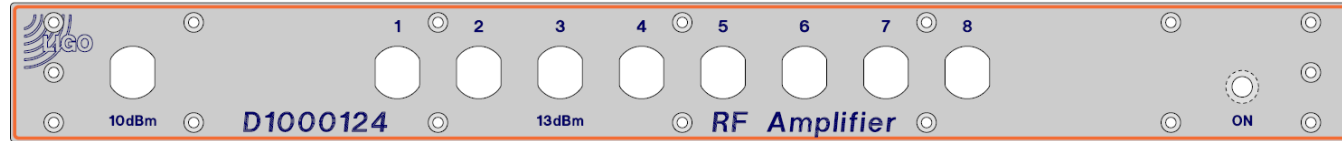

[D1000124](#)

Front

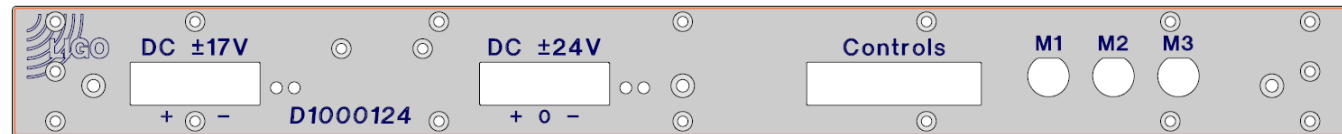

[S1001232](#)

Rear

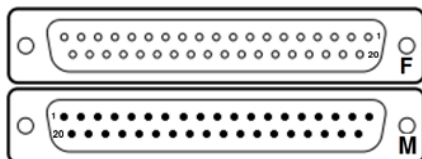

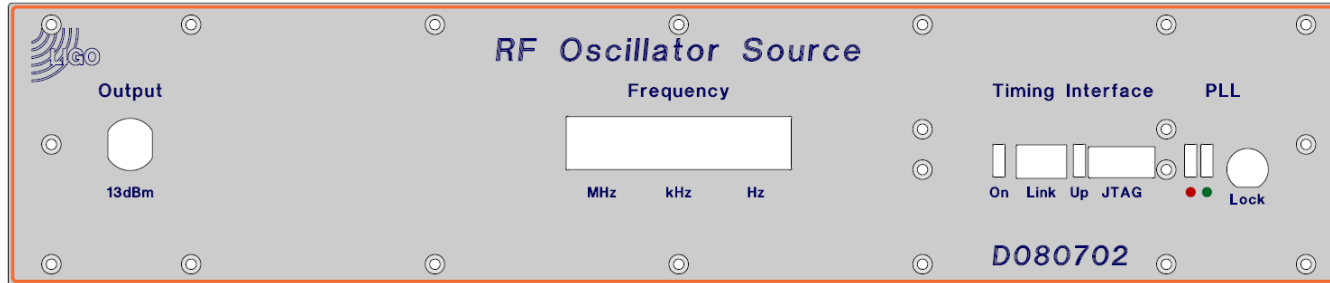

[D080702](#)

Front

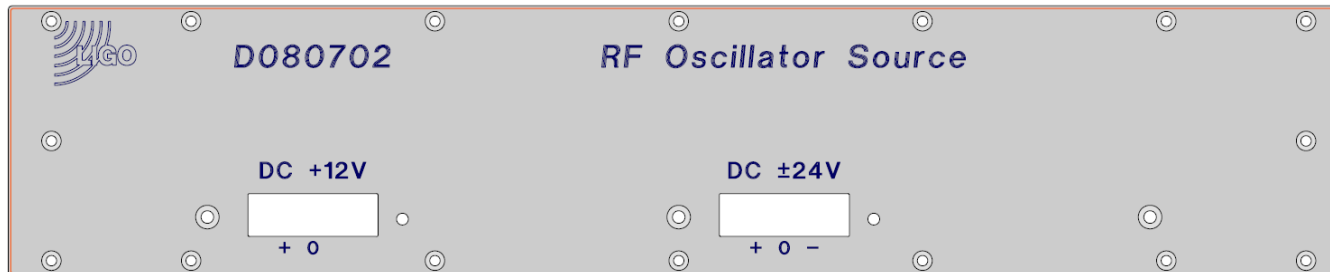

[S1001232](#)

Rear

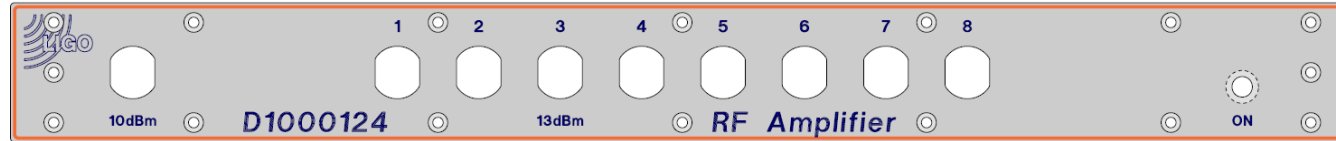

[D1000124](#)

Front

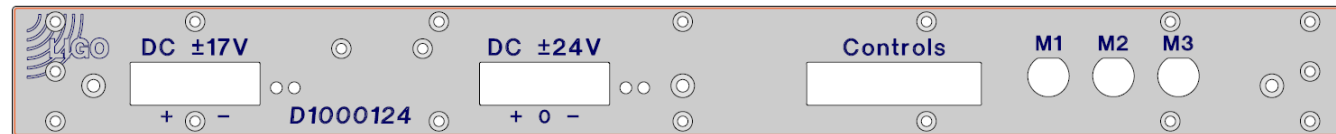

[S1001232](#)

Rear

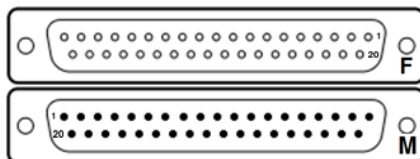

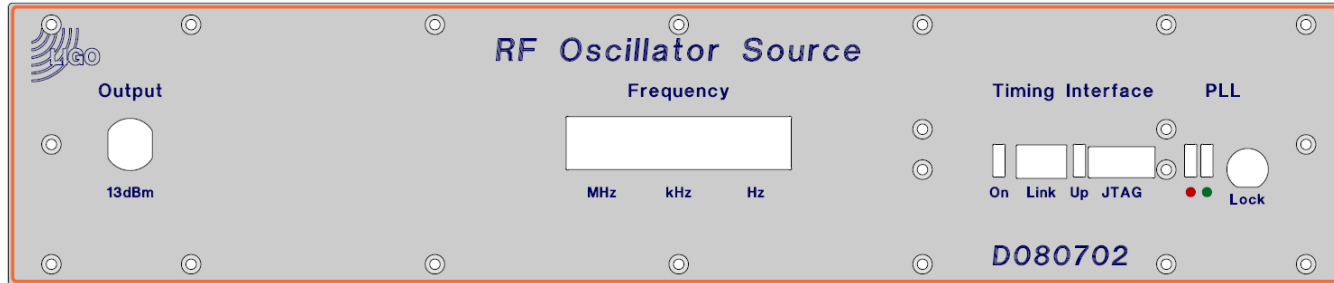

[D080702](#)

Front

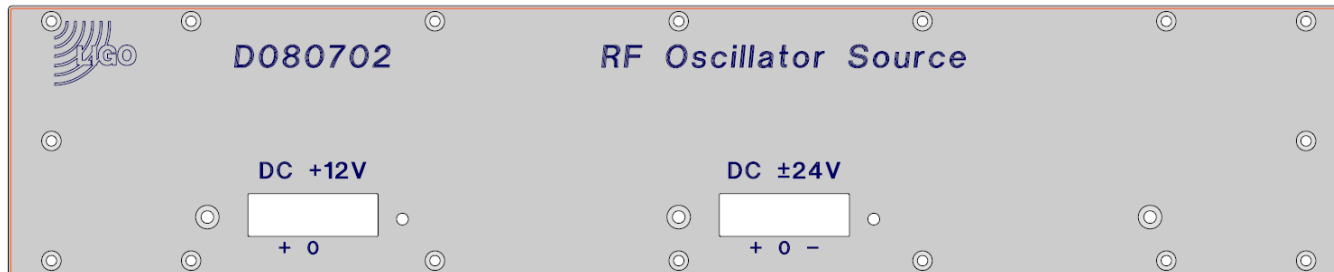

[S1001232](#)

Rear

D1000124 - Sxxxxxxx

<< L1-ISC-C4

71 MHz Distribution Amplifier D1000124 Sxxxxxxx ±17VDC, ±24VDC

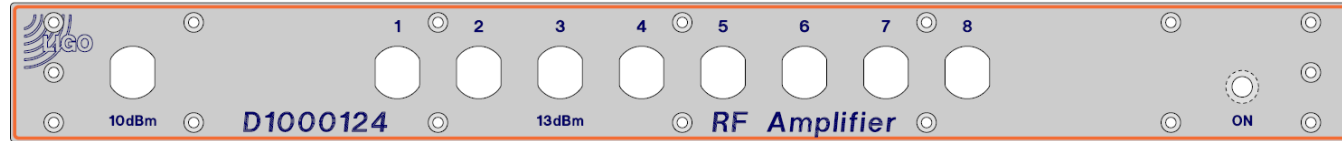

[D1000124](#)

Front

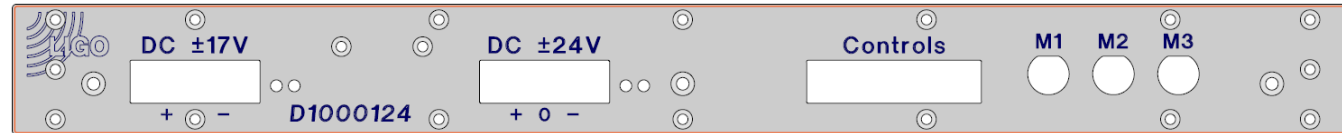

[S1001232](#)

Rear

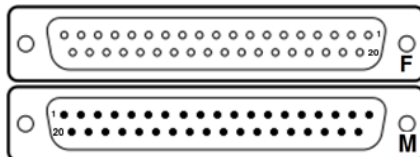

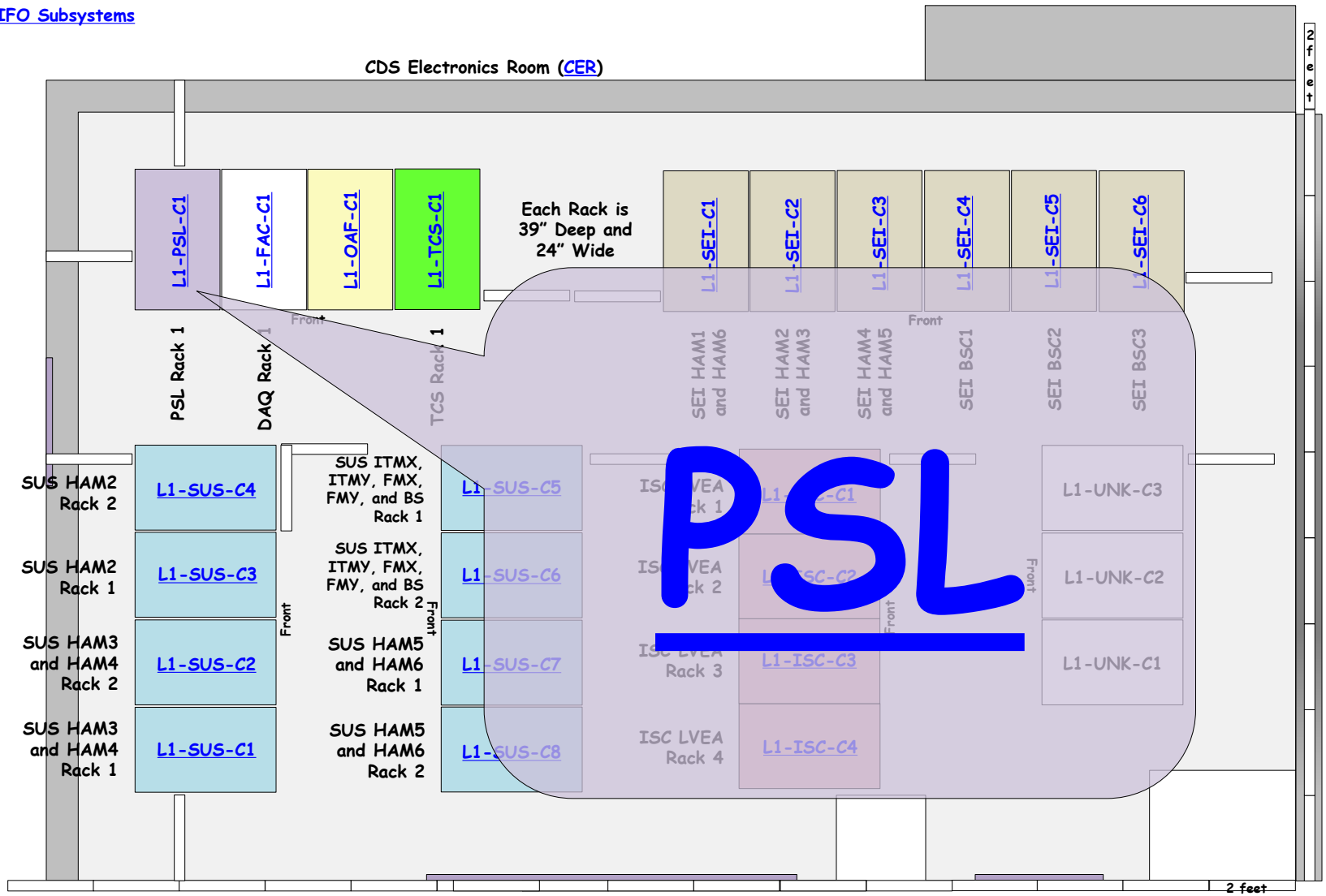

PSL Component List: [LIGO-T0900633](#)

PSL Table Layout: [LIGO-T0900610](#)

L1-PSL-C1

PSL Rack 1 Layout (LIGO-Dxxxxxxx)

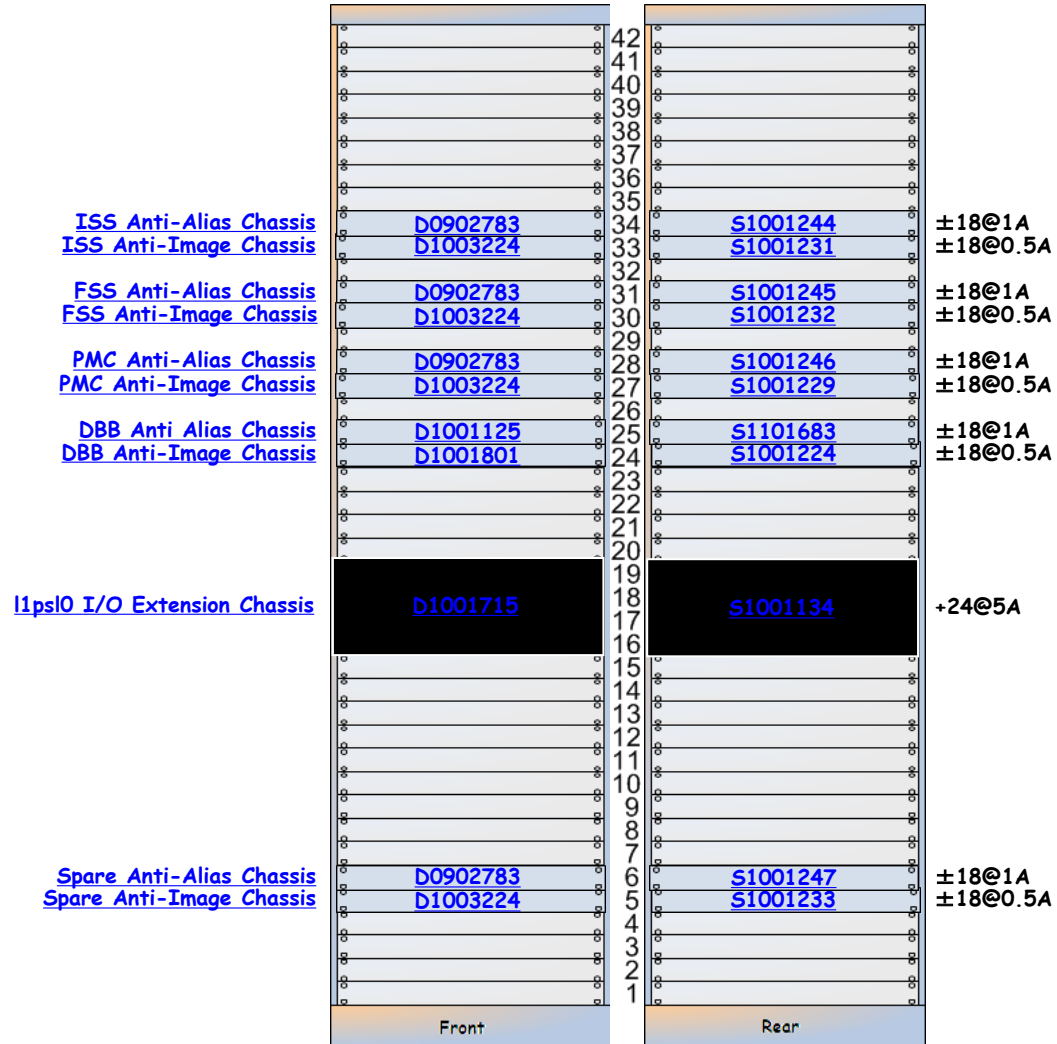

PSY-009



PSO-018

L1-PSL-C1 Details

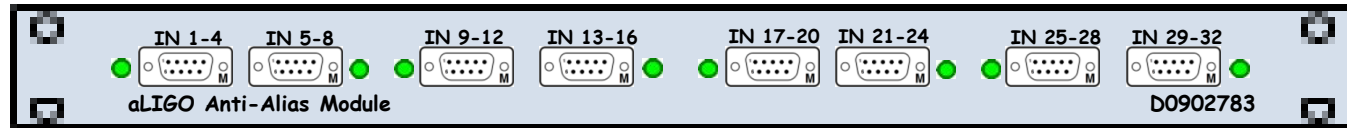
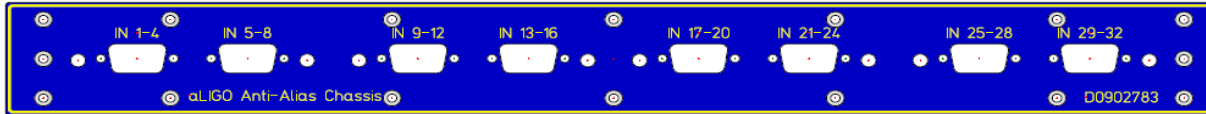

[D1003224](#)

Front

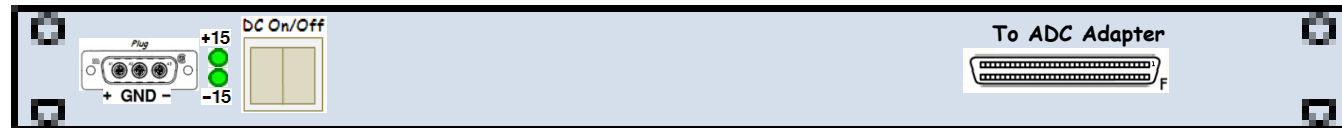
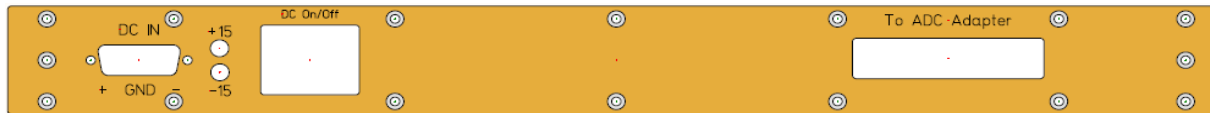
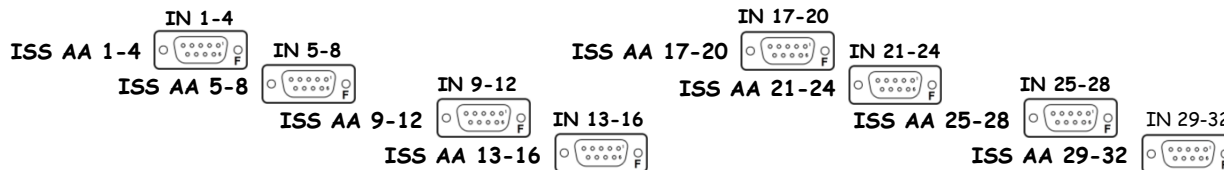

[S1001244](#)

Rear



[I1psIO Slot P1](#)

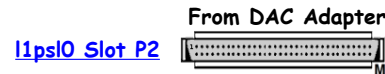
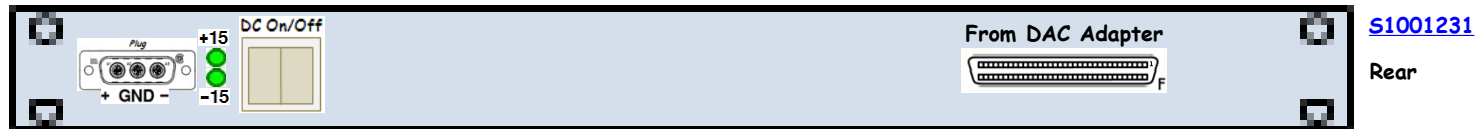
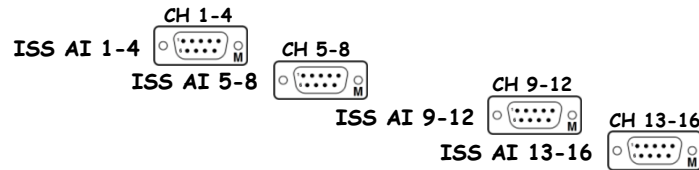
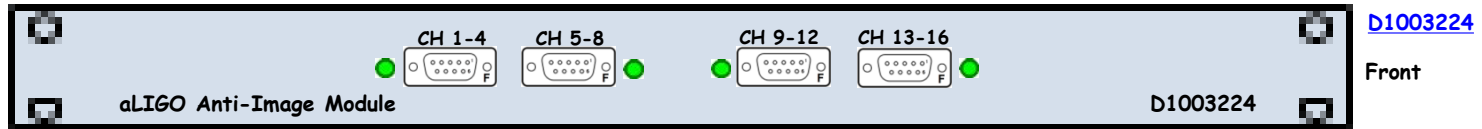

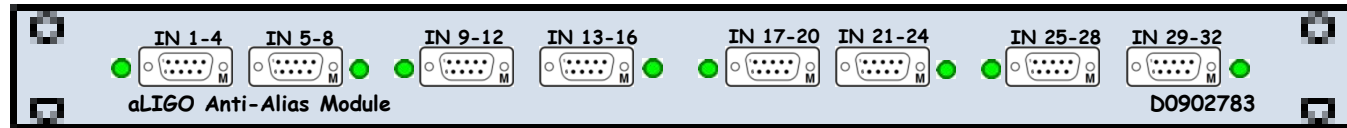
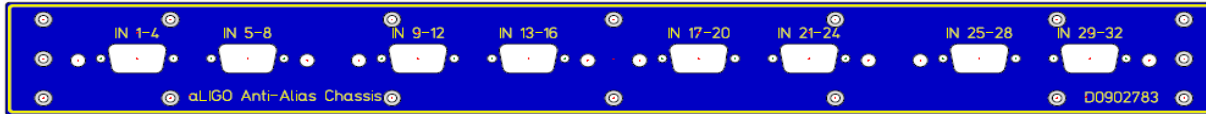

[D1003224](#)

Front

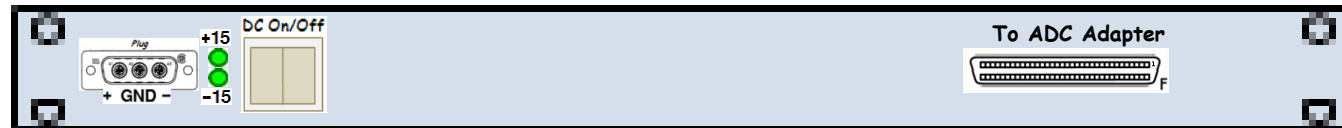
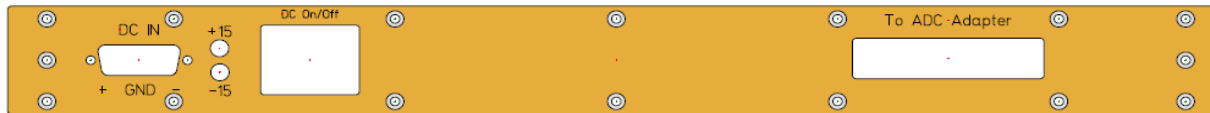
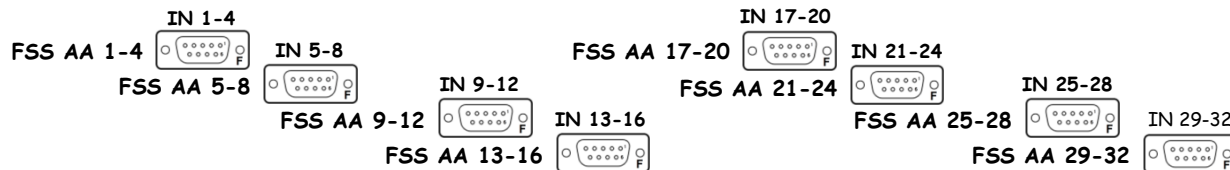

[S1001245](#)

Rear



[l1psIO Slot P3](#)

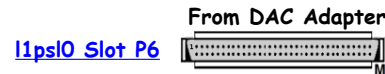
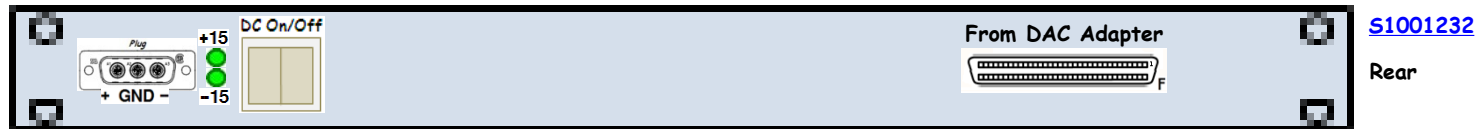
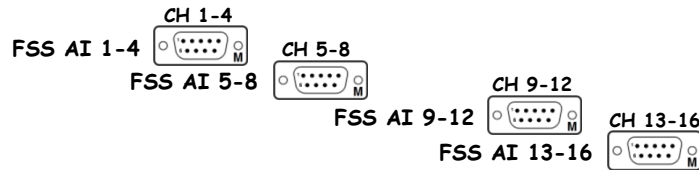
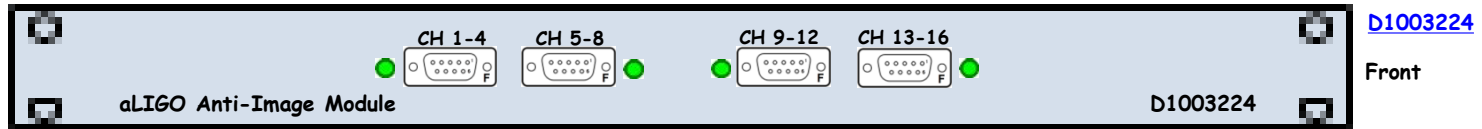

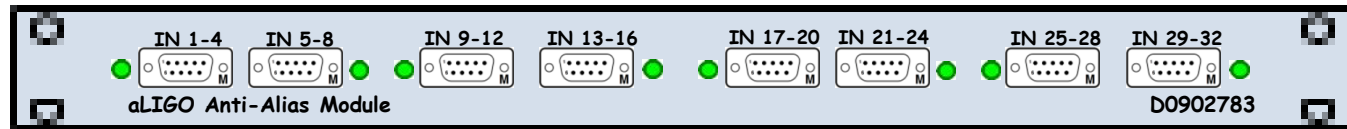
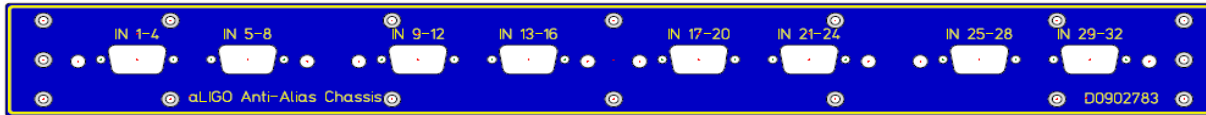

[D1003224](#)

Front

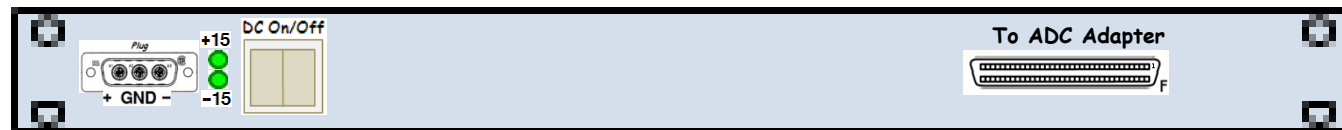
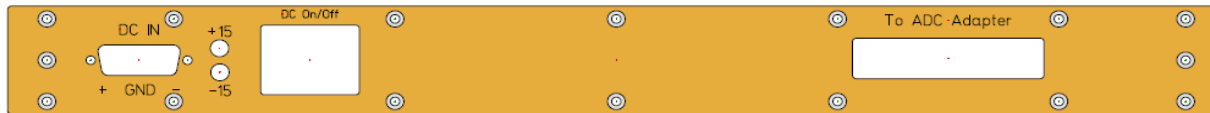
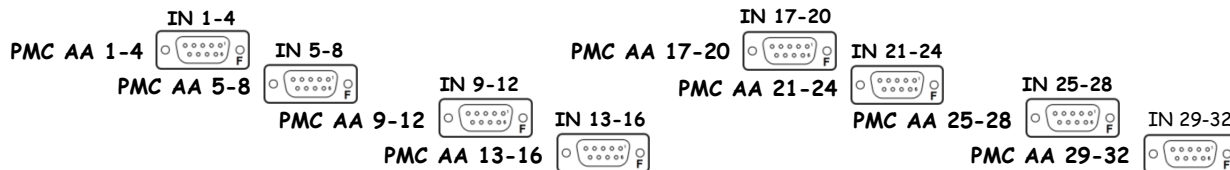

[S1001246](#)

Rear

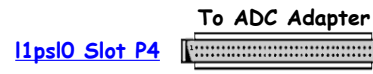

[I1psIO Slot P4](#)

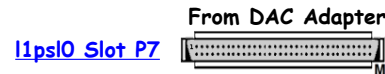
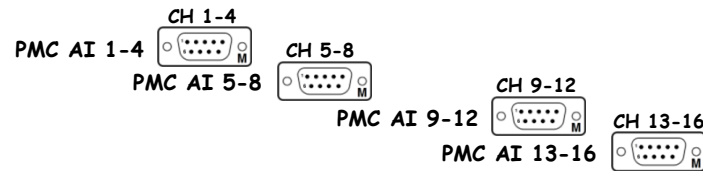
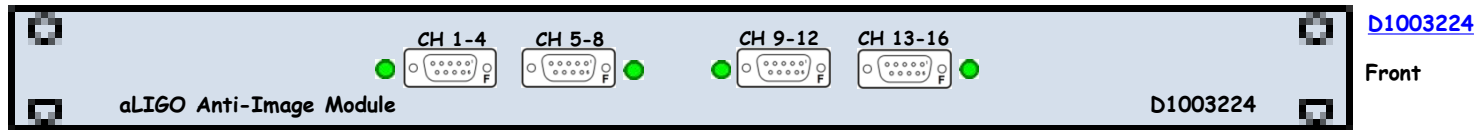

DBB Anti-Alias Chassis ±18@1.0A

AI Module aLIGO PSL DBB Assembly Drawing [D1100292](#)

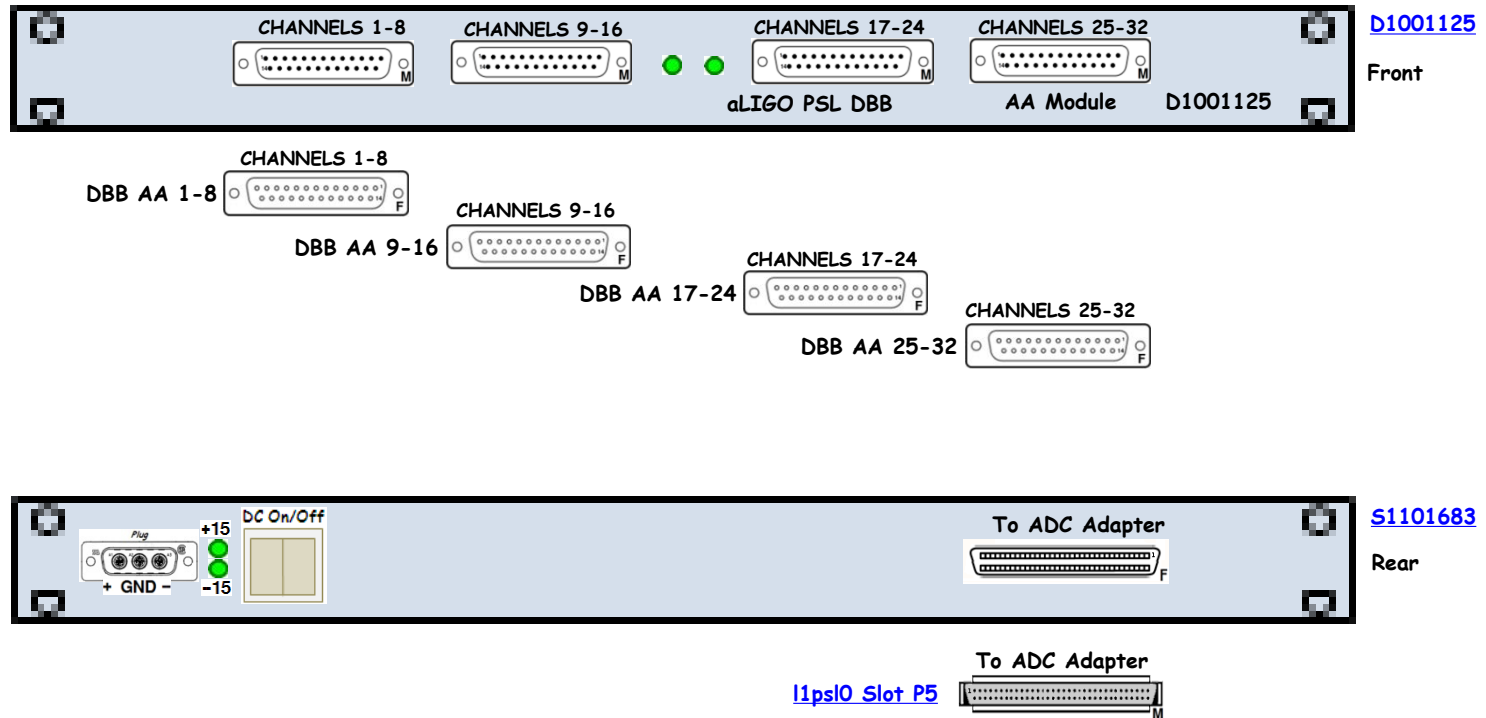

DBB Anti-Image Chassis ±18@0.5A

AI Module aLIGO PSL DBB Assembly Drawing [D1002103](#)

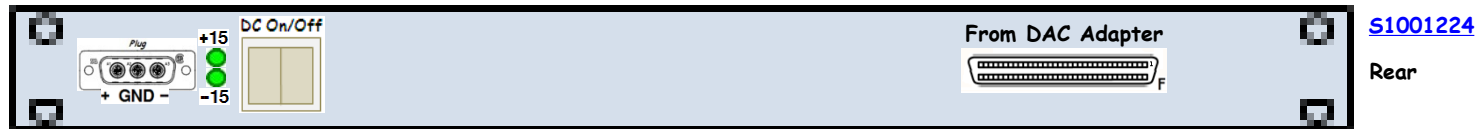
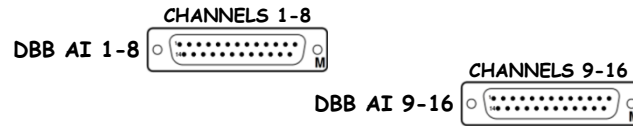

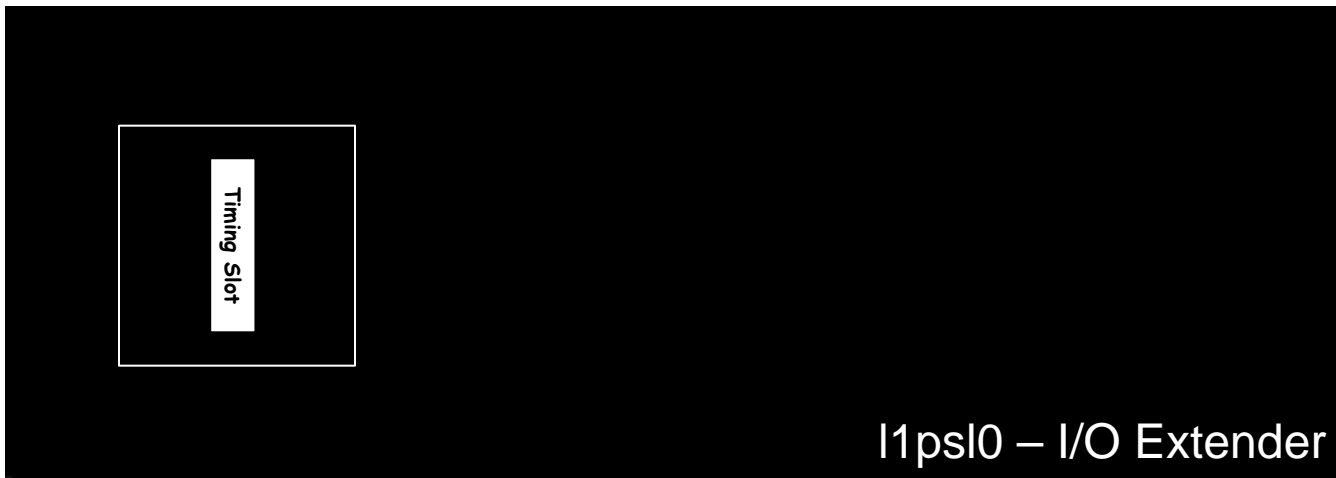

[D1001715](#)

Front

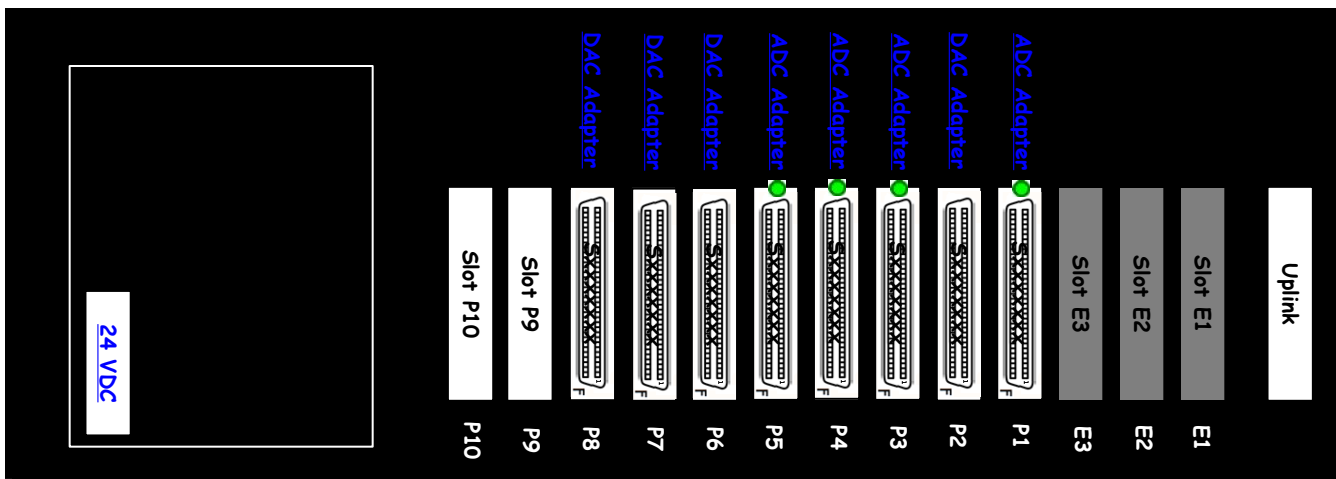

[S1001134](#)

Rear

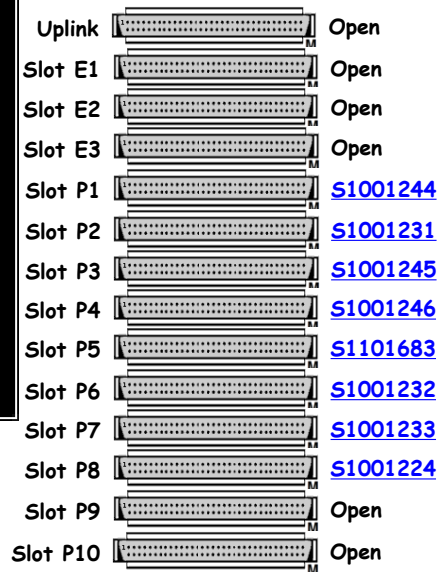

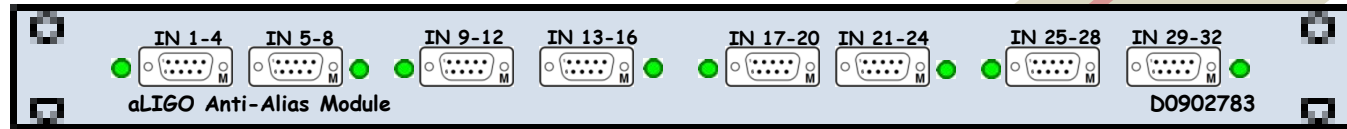
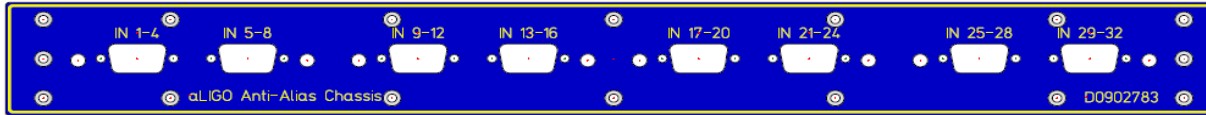

[D1003224](#)

Front

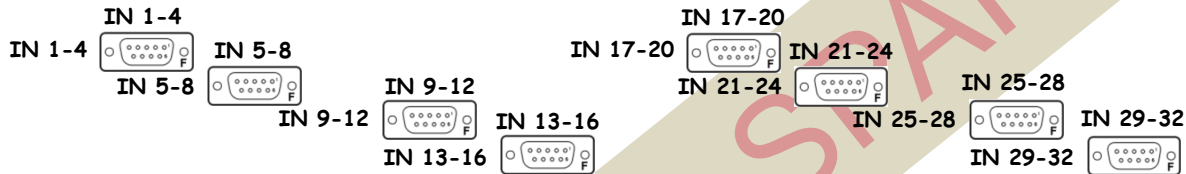

[S1001247](#)

Rear



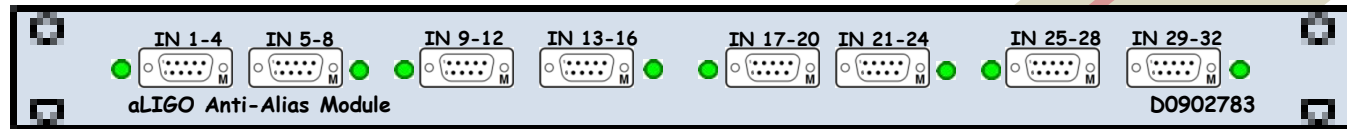
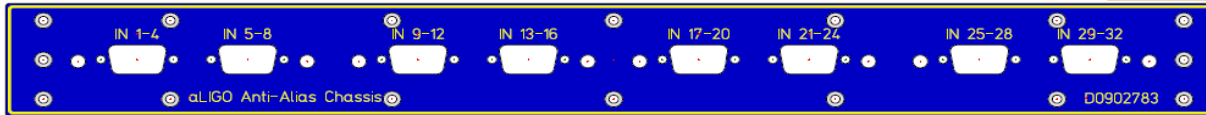

D1003224

Front

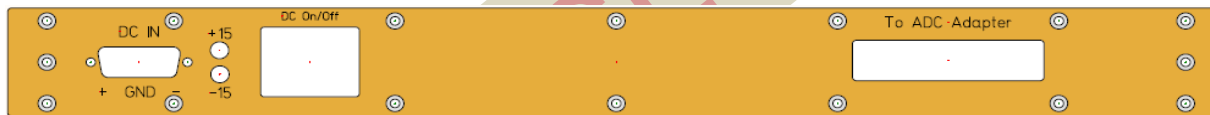
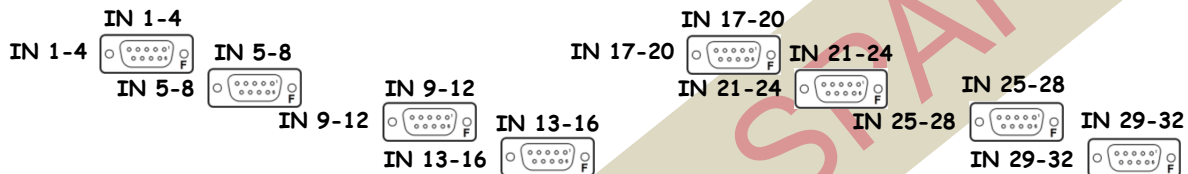

S1001248

Rear

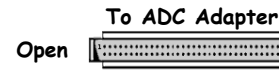

Anti-Image Chassis ±18@0.5A

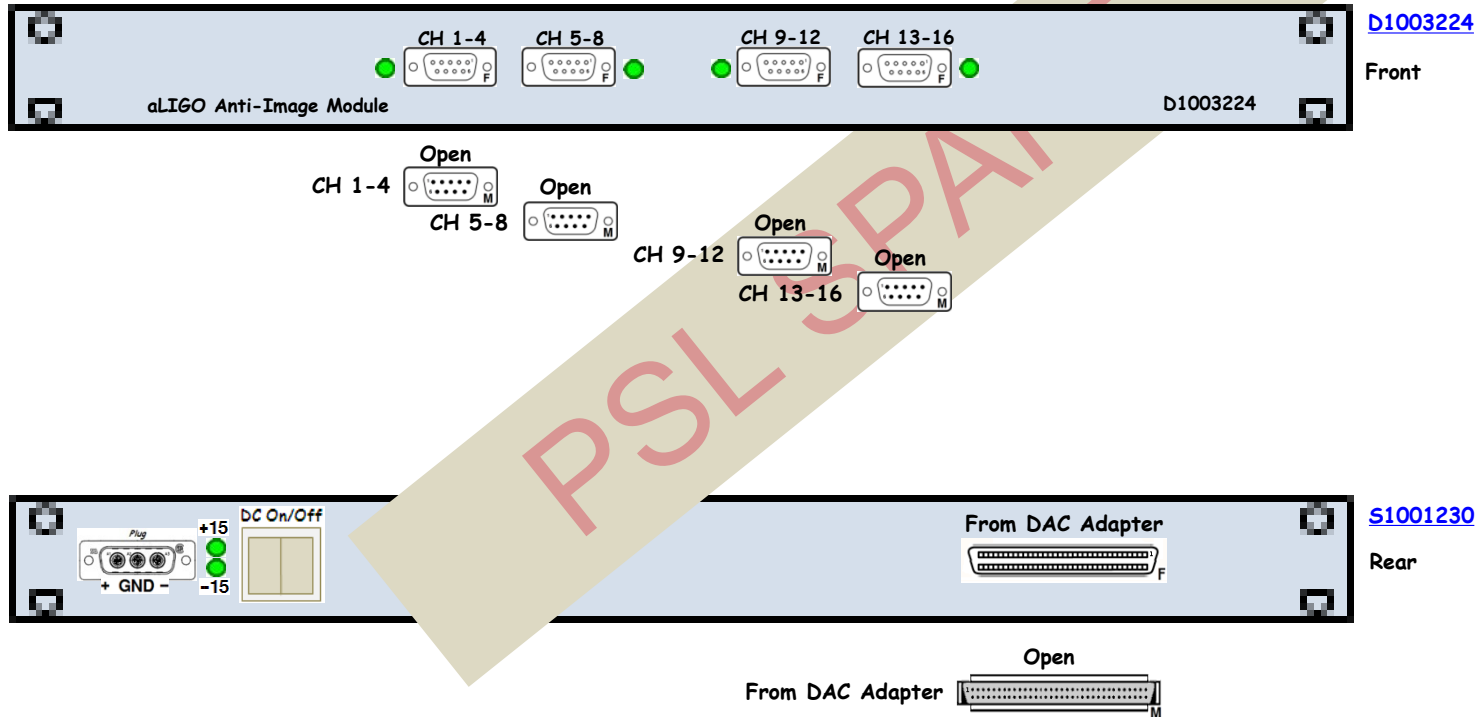

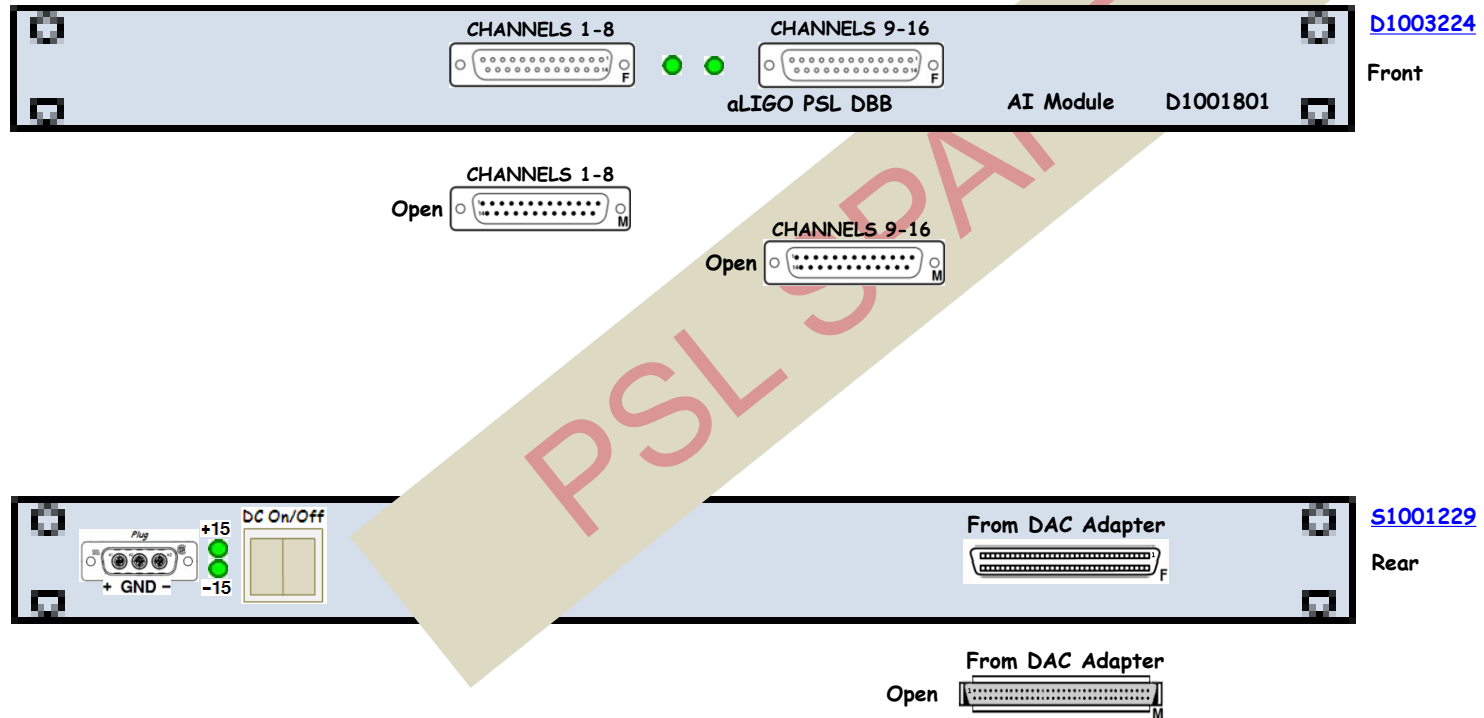

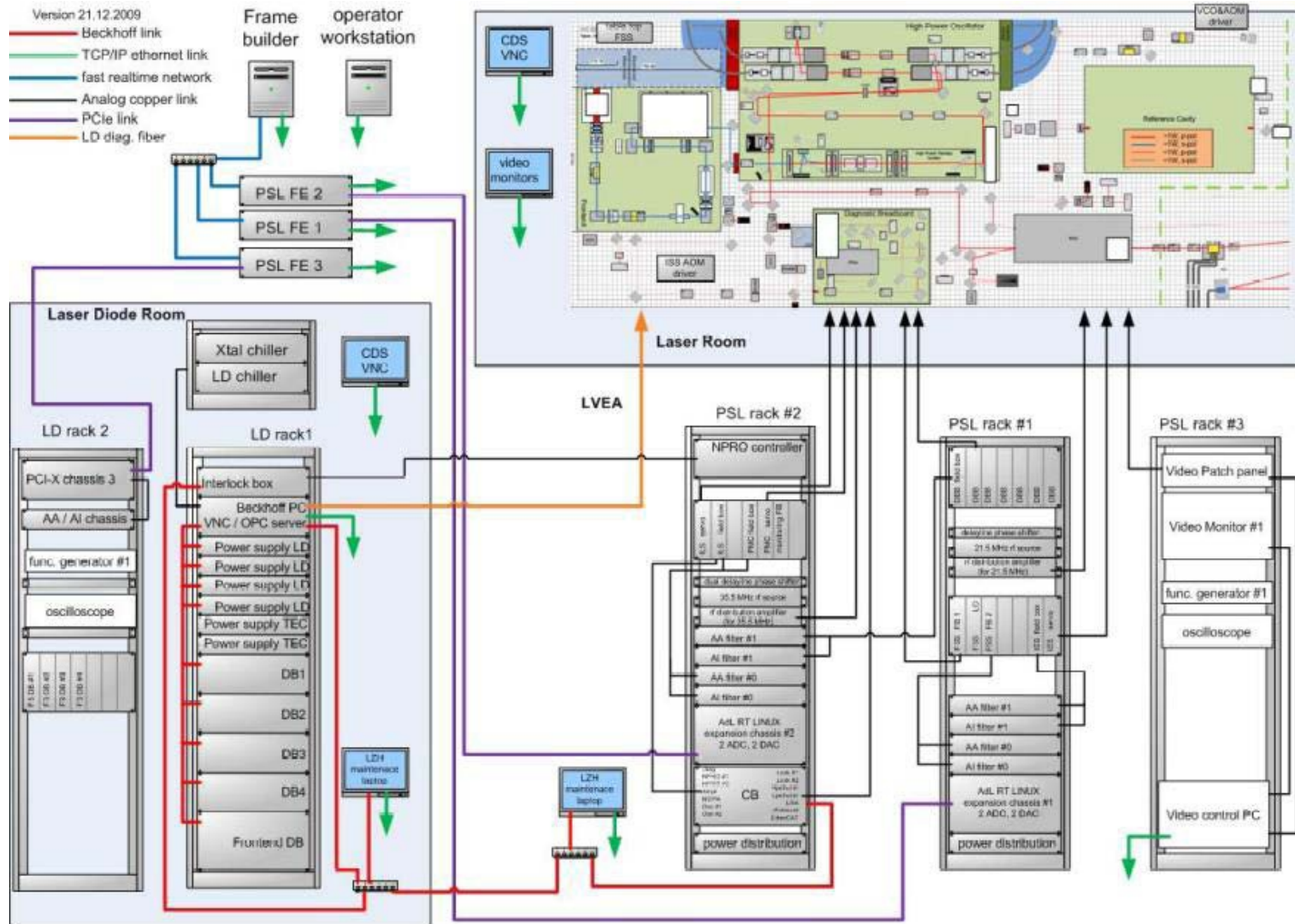

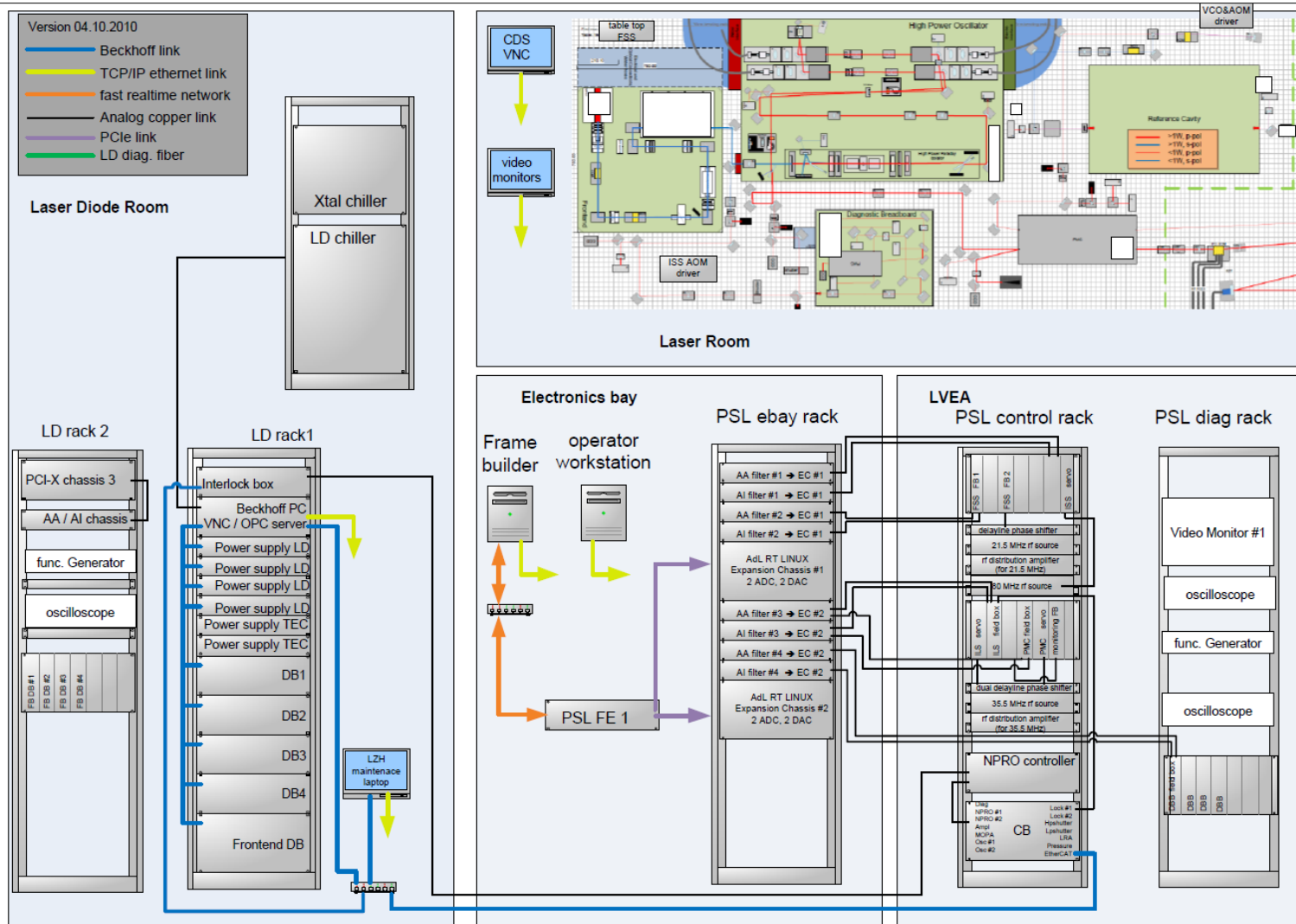

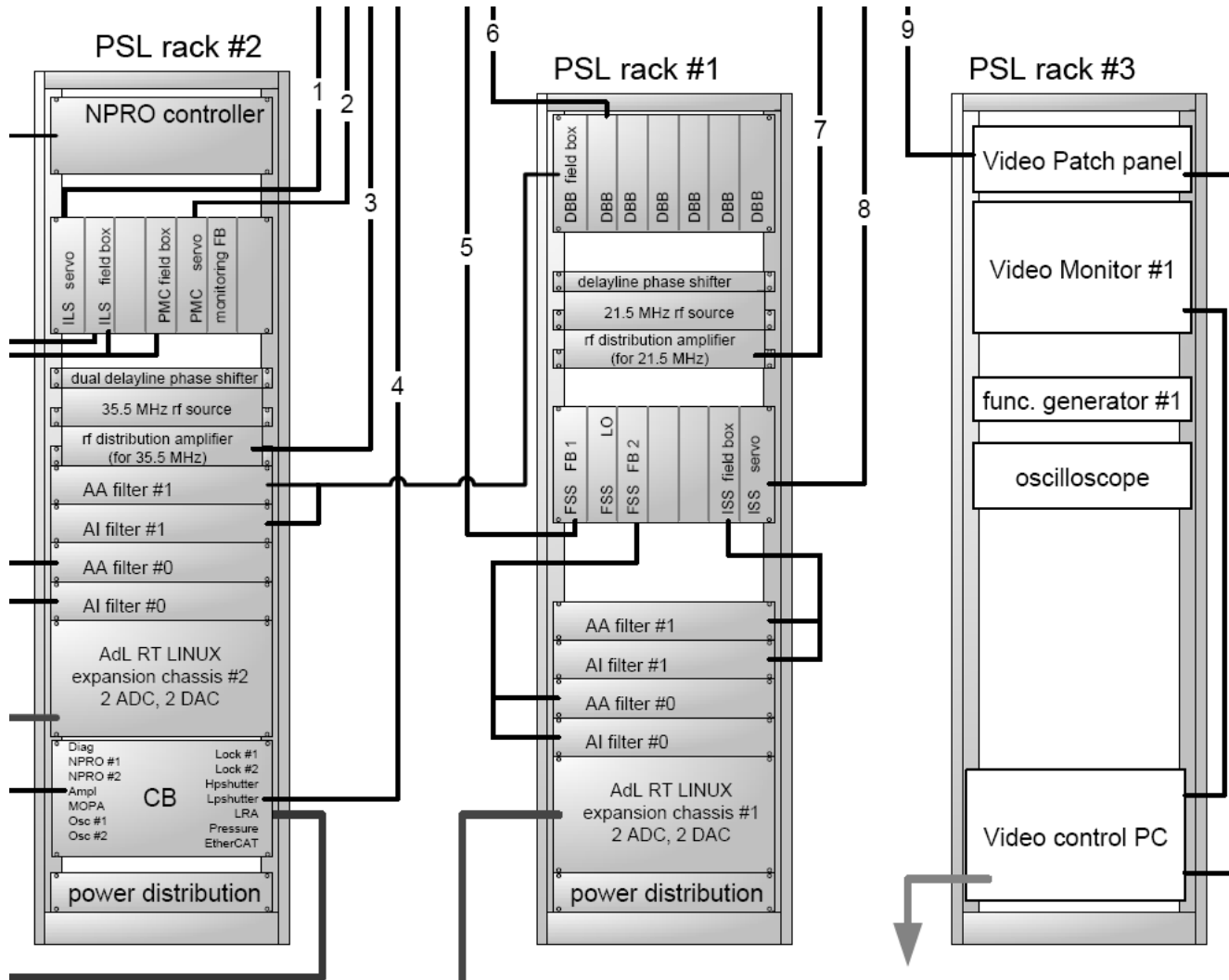

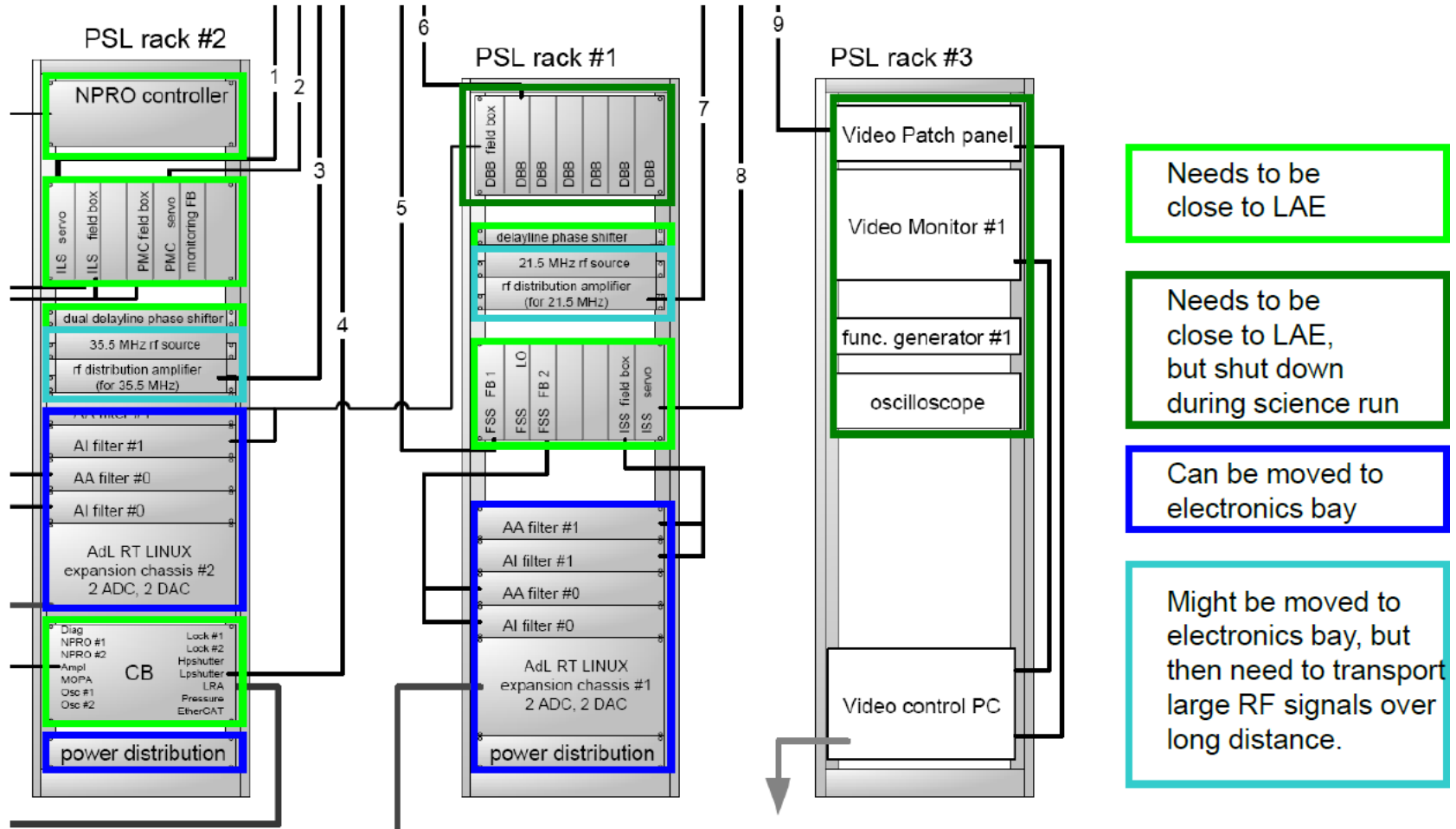



PSL RACKS - L1-PSL-01 - ILS and PMC

L1-PSL-01
Front

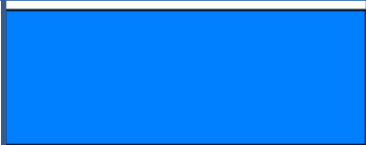

NPRO
Controller

Eurocard
Crate
ECC-1 (ILS
and PMC)

DXXXXXXXXX Delay Line Chassis



DXXXXXXXXX 35.5MHz Amplifier Chassis



DXXXXXXXXX 35.5MHz Amplifier Chassis



D1000305 AI Chassis
D1000305 AI Chassis
D0902783 AA Chassis
D0902783 AA Chassis

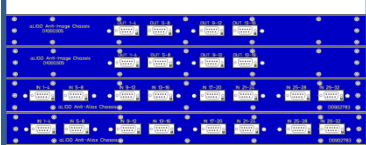

I/O Extension
2 ADC
2 DAC



Control Box
(CB)



L1-PSL-01
Rear



NPRO
Controller

Eurocard
Crate
ECC-1 (ILS
and PMC)

DXXXXXXXXX SYYYYYYYYY



DXXXXXXXXX SYYYYYYYYY



DXXXXXXXXX SYYYYYYYYY



D1000305 SYYYYYYYYY
D1000305 SYYYYYYYYY
D0902783 SYYYYYYYYY
D0902783 SYYYYYYYYY

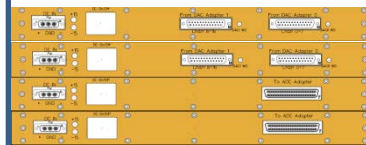

Control Box
(CB)

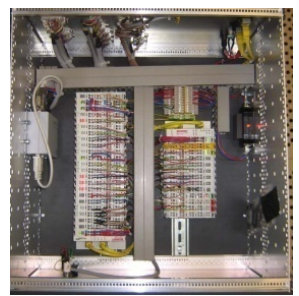
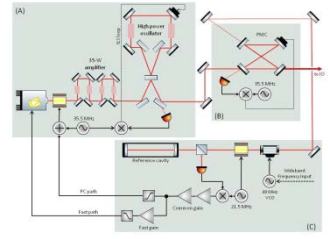
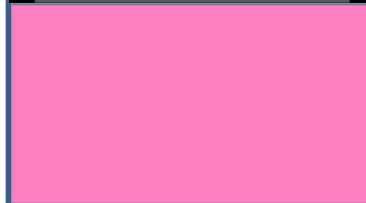



PSL RACKS - L1-PSL-02 (DBB, FSS, and ISS)

L1-PSL-02
Front Eurocard
Crate
ECC-1 (DBB)

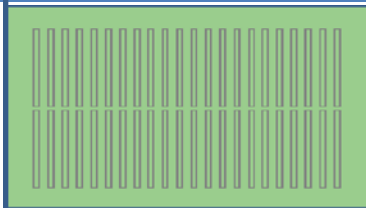

Eurocard
Crate
ECC-2 (FSS
and ISS)

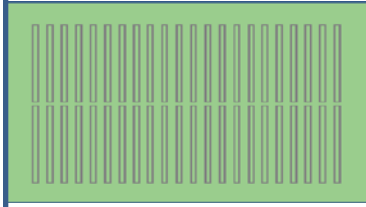

DXXXXXXXXX Delay Line Chassis



DXXXXXXXXX 21.5MHz Amplifier Chassis

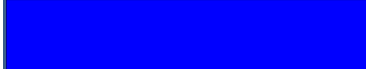

DXXXXXXXXX 21.5MHz Amplifier Chassis



D1000305 AI Chassis
D1000305 AI Chassis
D0902783 AA Chassis
D0902783 AA Chassis

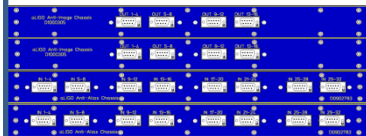

I/O Extension
2 ADC
2 DAC



Frequency Stabilization Servo
Intensity Stabilization Servo
Diagnostic Breadboard

L1-PSL-02
Rear Eurocard
Crate
ECC-1 (DBB)

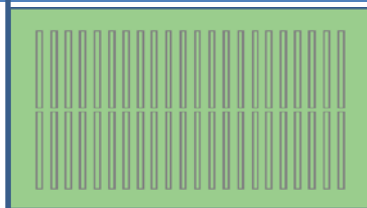

Eurocard
Crate
ECC-2 (FSS
and ISS)

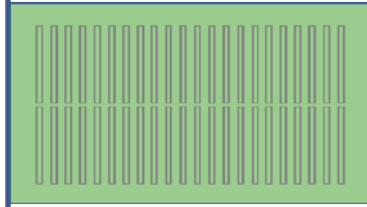

DXXXXXXXXX SYYYYYYYYY



DXXXXXXXXX SYYYYYYYYY



DXXXXXXXXX SYYYYYYYYY



D1000305 SYYYYYYYYY
D1000305 SYYYYYYYYY
D0902783 SYYYYYYYYY
D0902783 SYYYYYYYYY

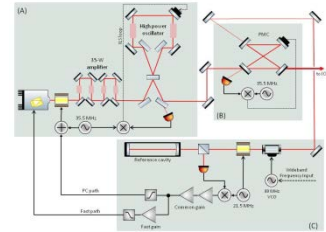
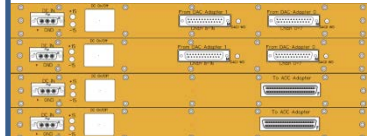

L1-PSL-02-ECC-1 (DBB)

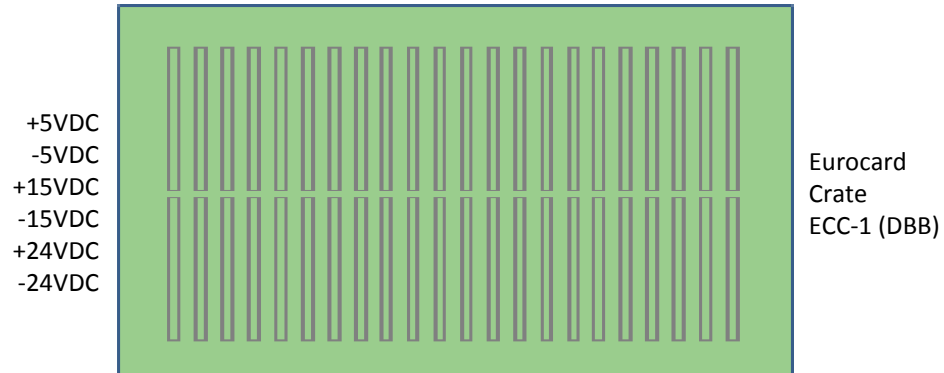
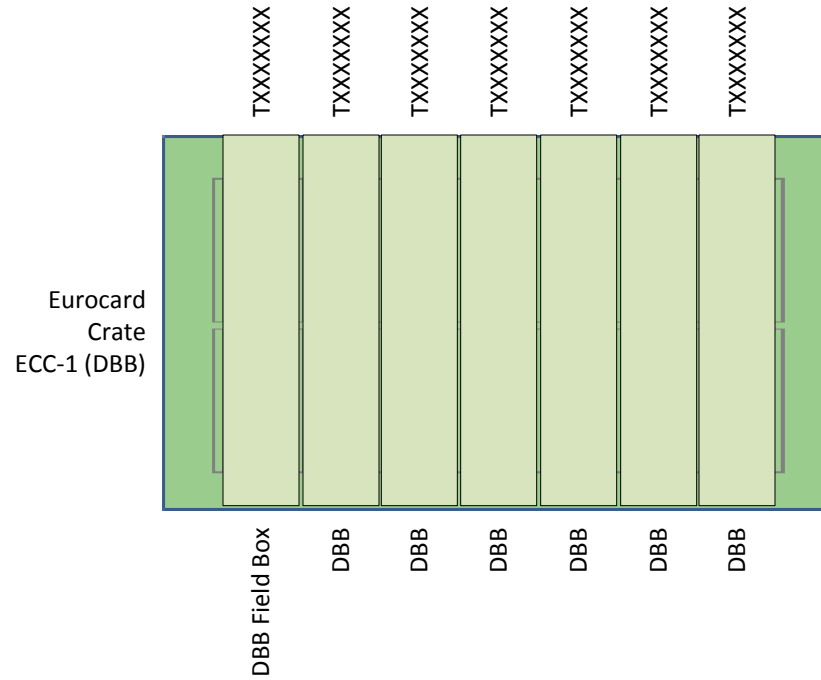

L1-PSL-02-ECC-2 (FSS and ISS)

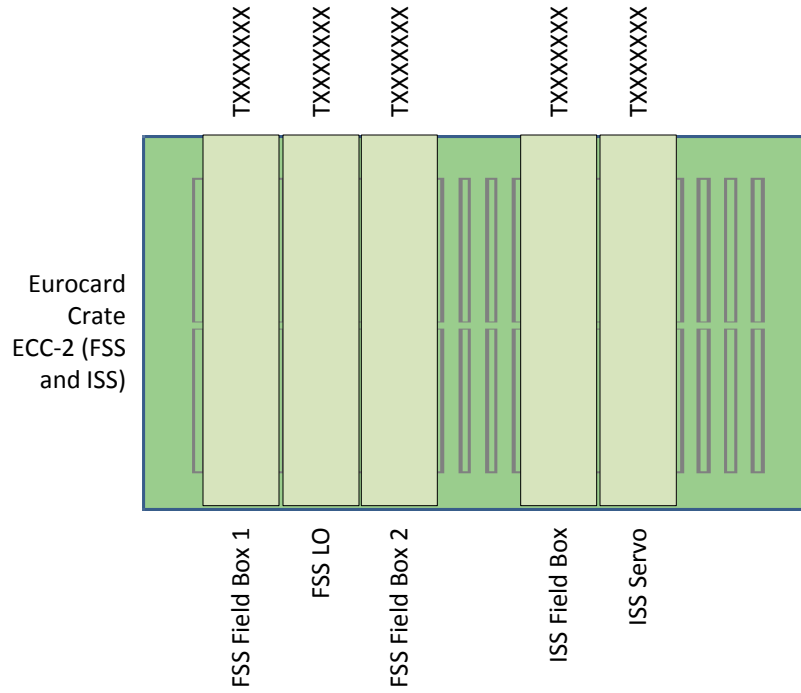

+5VDC
-5VDC
+15VDC
-15VDC
+24VDC
-24VDC

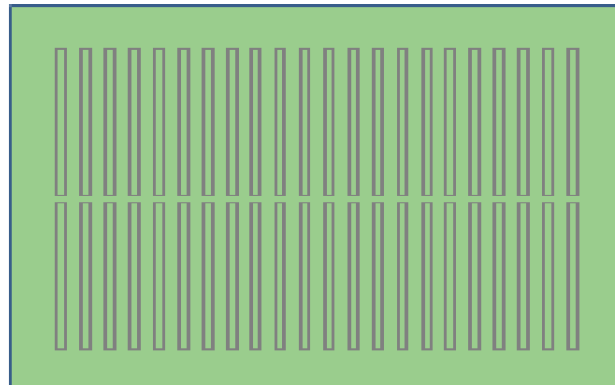

Eurocard
Crate



NPRO
Controller

L1-PSL-01
Front

Eurocard
Crate
ECC-1 (DBB)

Eurocard
Crate
ECC-2 (FSS
and ISS)

Eurocard
Crate
ECC-3 (ILS
and PMC)

DXXXXXXXXX Delay Line Chassis

DXXXXXXXXX 21.5MHz Amplifier Chassis

DXXXXXXXXX 21.5MHz Amplifier Chassis

DXXXXXXXXX Delay Line Chassis

DXXXXXXXXX 35.5MHz Amplifier Chassis

DXXXXXXXXX 35.5MHz Amplifier Chassis

Control Box
(CB)

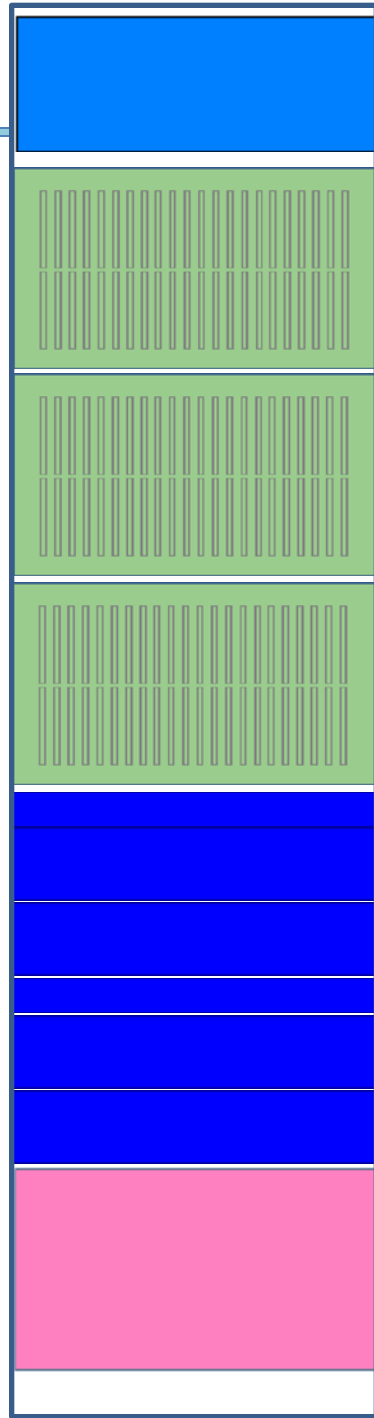

NPRO
Controller

L1-PSL-01
Rear

Eurocard
Crate
ECC-1 (DBB)

Eurocard
Crate
ECC-2 (FSS
and ISS)

Eurocard
Crate
ECC-3 (ILS
and PMC)

DXXXXXXXXX SYYYYYYYYY

DXXXXXXXXX SYYYYYYYYY

DXXXXXXXXX SYYYYYYYYY

DXXXXXXXXX SYYYYYYYYY

DXXXXXXXXX SYYYYYYYYY

DXXXXXXXXX SYYYYYYYYY

Control Box
(CB)

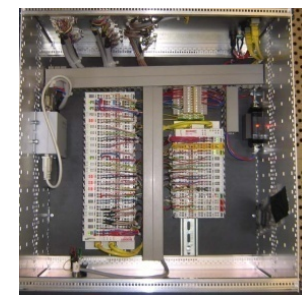
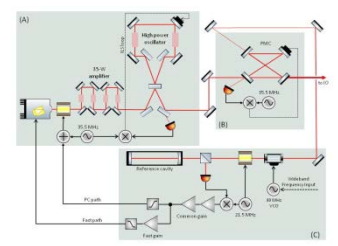
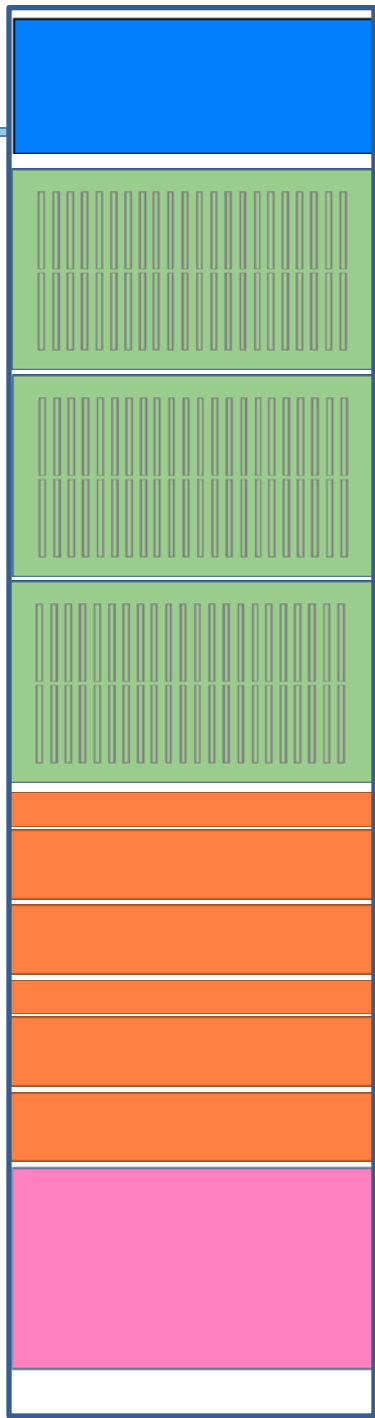



PSL Table

[T0900610](#)

LDR Rack 1 Layout (LIGO-Dxxxxxxx)

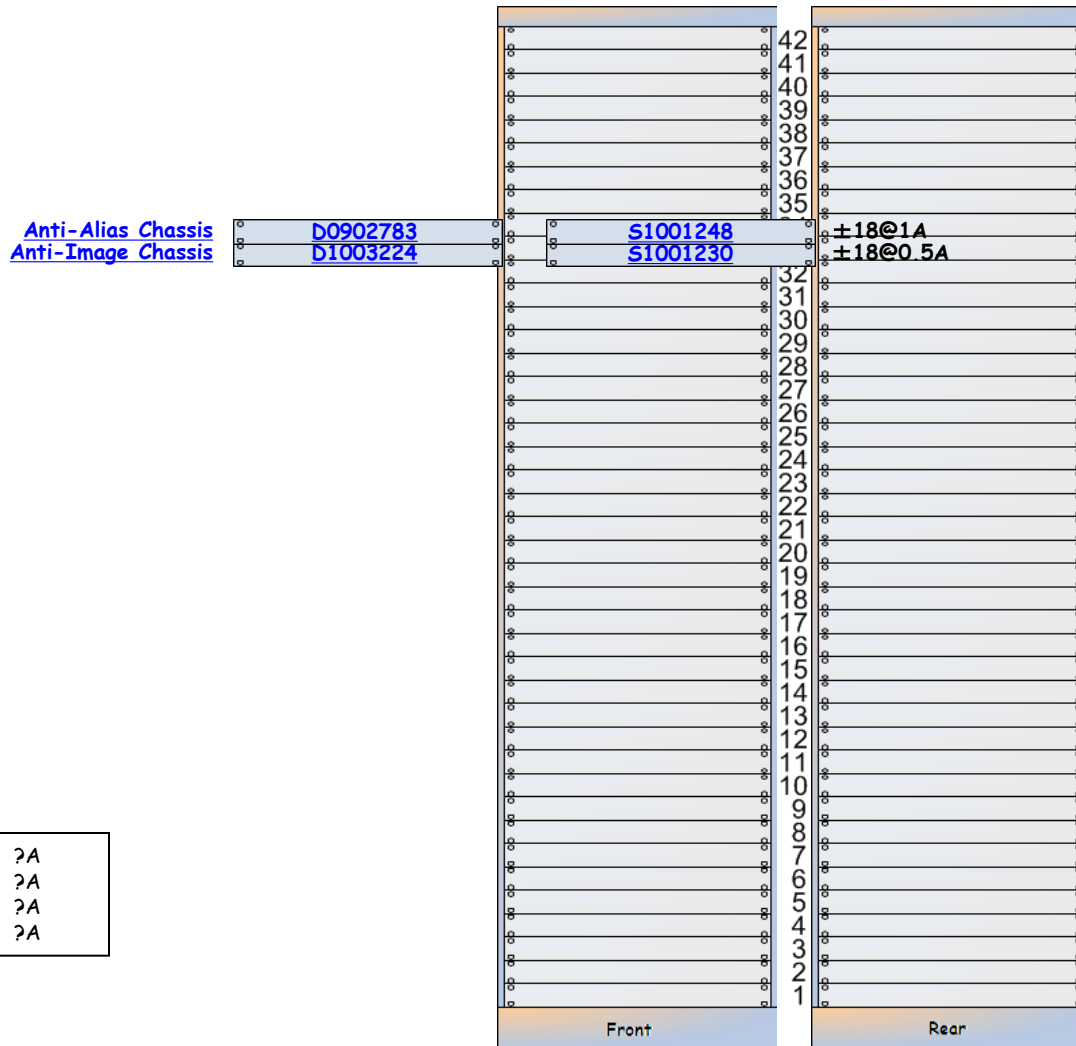

| | |
|--------|----|
| +18VDC | ?A |
| -18VDC | ?A |
| +24VDC | ?A |
| -24VDC | ?A |

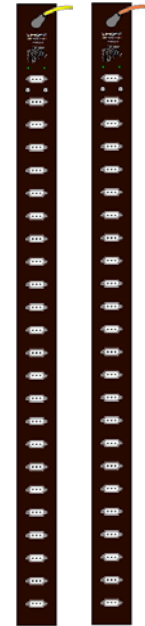

L1-LDR-C2

LDR Rack 2 Layout (LIGO-Dxxxxxxx)



| | |
|--------|----|
| +18VDC | ?A |
| -18VDC | ?A |
| +24VDC | ?A |
| -24VDC | ?A |

L1-LDR-C3

LDR Rack 3 Layout (LIGO-Dxxxxxxx)

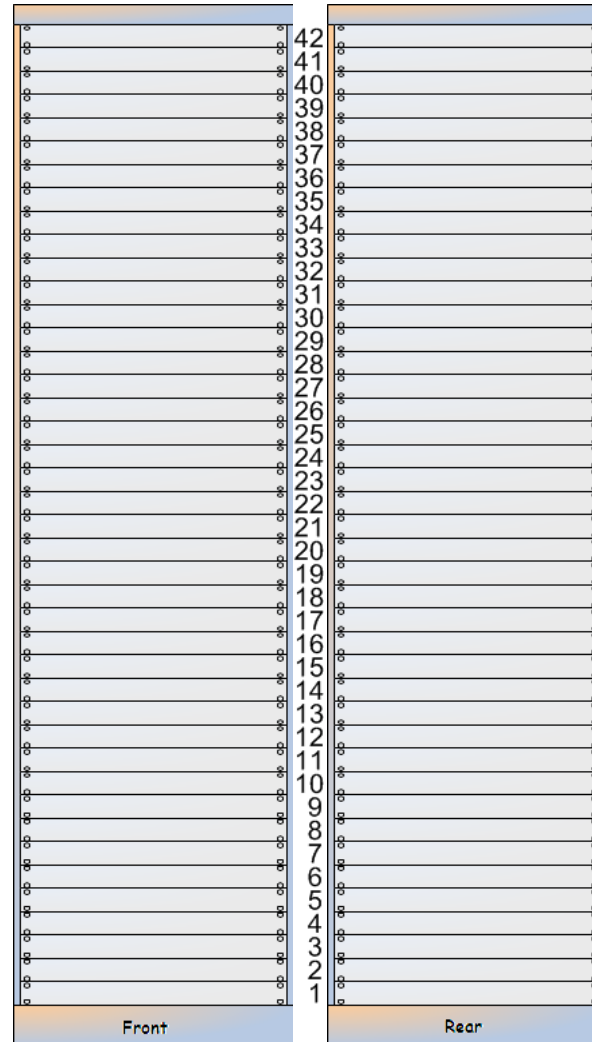

| | |
|--------|----|
| +18VDC | ?A |
| -18VDC | ?A |
| +24VDC | ?A |
| -24VDC | ?A |

LDR Chiller

LDR Rack 4 Layout (Chillers) (LIGO-Dxxxxxxx)

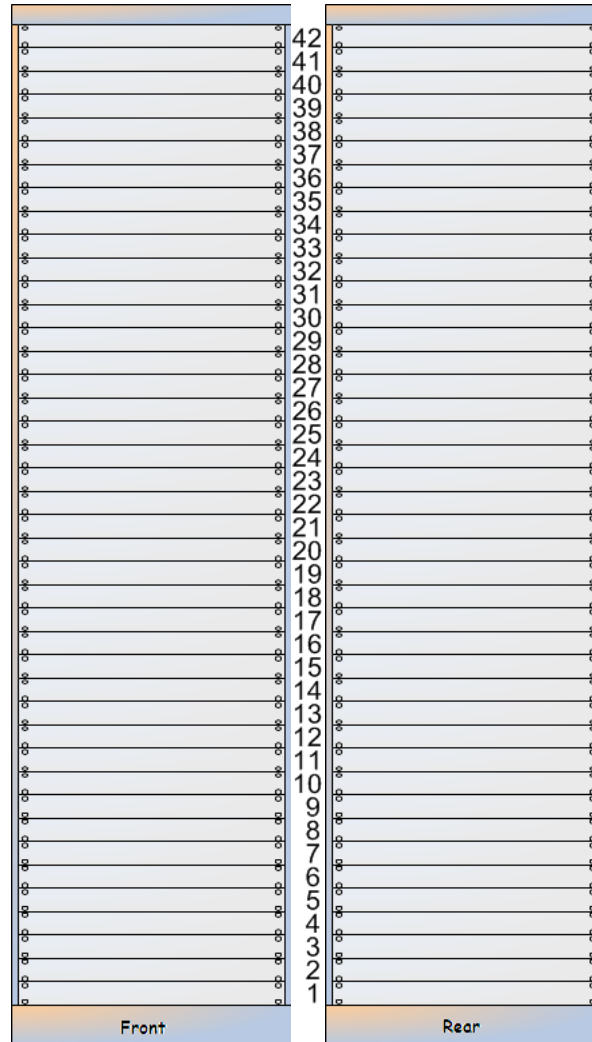

| | |
|--------|----|
| +18VDC | ?A |
| -18VDC | ?A |
| +24VDC | ?A |
| -24VDC | ?A |

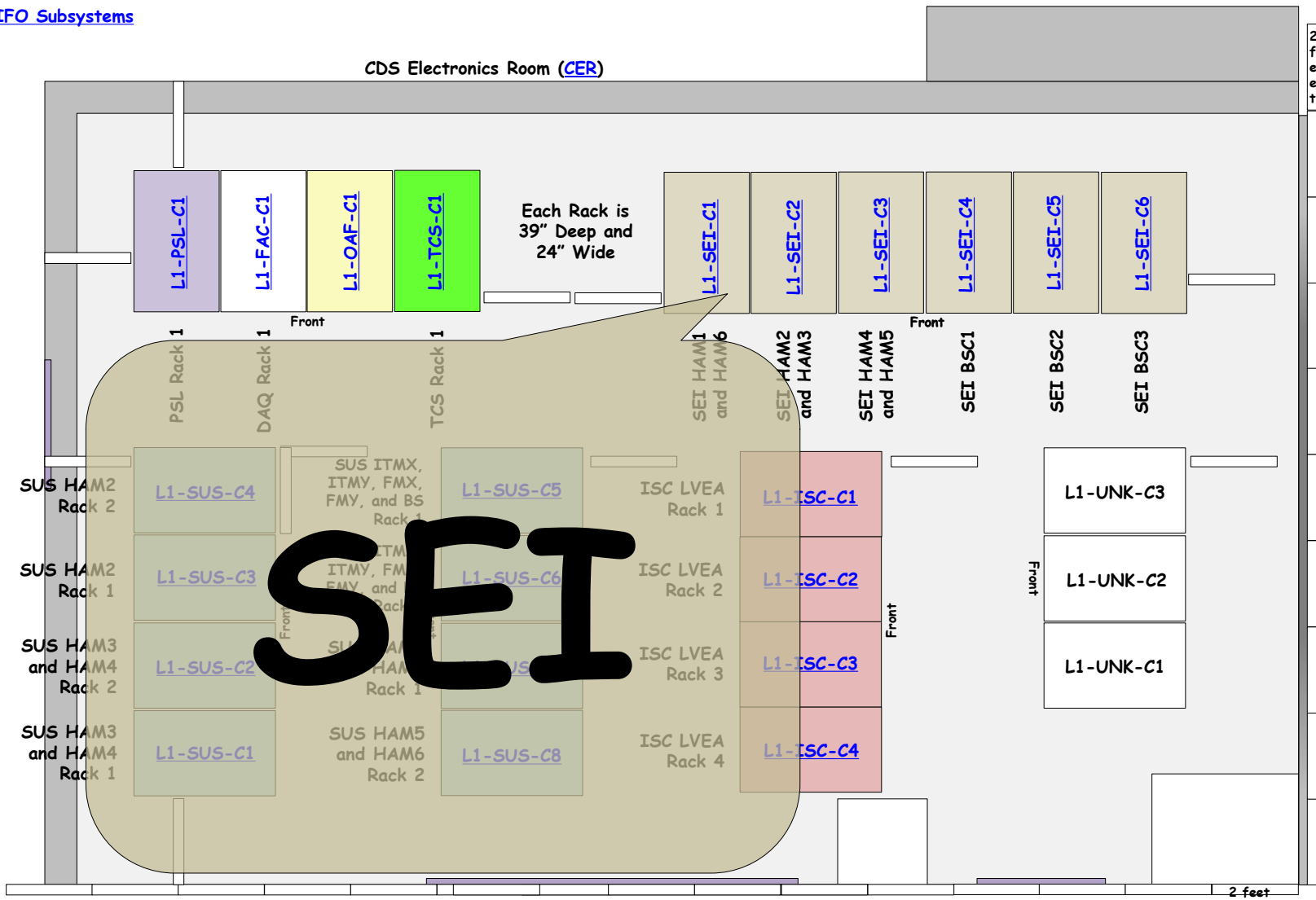

| | | | |
|----------------------------------|--------------------------|--------------------------|------------------------|
| HAM2 HEPI 8-Channel Valve Driver | D0900117 | S0900275 | +18V@0.72A, -18V@0.72A |
| HAM3 HEPI 8-Channel Valve Driver | D0900117 | S0900290 | +18V@0.72A, -18V@0.72A |

HAMs 1&6 L1-SEI-C1

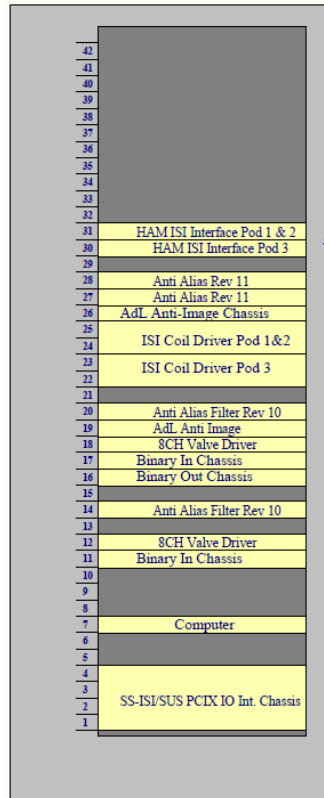

HAM6 ISI Interface Chassis
HAM6 ISI Interface Chassis

Anti-Alias Chassis
Anti-Alias Chassis
Anti-Image Chassis

HAM6 ISI Coil Driver Pod 1 and Pod 2

ISI 6 **HAM6 ISI Coil Driver Pod 3**

Anti-Image Chassis
Anti-Alias Chassis

HAM1 HEPI 8-Channel Valve Driver
Binary Input Chassis
Binary Output Chassis

HEPI 1

HAM6 HEPI 8-Channel Valve Driver

HEPI 6

l1seiham1-6 I/O Extension Chassis

| | | | |
|----|-----------------|-----------------|------------------------------------|
| 42 | | | |
| 41 | | | |
| 40 | | | |
| 39 | | | |
| 38 | | | |
| 37 | | | |
| 36 | | | |
| 35 | | | |
| 34 | | | |
| 33 | | | |
| 32 | | | |
| 31 | D100067 | Serial | +18V@0.32A, -18V@0.33 |
| 30 | D100067 | Serial | +18V@0.32A, -18V@0.33 |
| 29 | Dnumber | Serial | ±18@1A |
| 28 | Dnumber | Serial | ±18@1A |
| 27 | Dnumber | Serial | ±18@0.5A |
| 26 | Dnumber | Serial | ±18@0.5A |
| 25 | D0902744 | SN: | +24V@1.2A, -24V@0.8A (+10A) |
| 24 | | SN: | +24V@1.2A, -24V@0.8A (+10A) |
| 23 | D0902744 | SN: | +24V@1.2A, -24V@0.8A (+10A) |
| 22 | | SN: | +24V@1.2A, -24V@0.8A (+10A) |
| 21 | Dnumber | Serial | ±18@0.5A |
| 20 | Dnumber | Serial | ±18@1A |
| 19 | D020373 | S1000842 | +18V@0.72A, -18V@0.72A |
| 18 | Dxxxxxxx | SN: | ±18@0.5A |
| 17 | Dxxxxxxx | SN: | ±18@0.5A |
| 16 | | Serial | ±18@1A |
| 15 | Dnumber | Serial | ±18@1A |
| 14 | | Serial | +18V@0.72A, -18V@0.72A |
| 13 | | Serial | +18V@0.72A, -18V@0.72A |
| 12 | D0901338 | Serial | +18V@0.72A, -18V@0.72A |
| 11 | | | |
| 10 | | | |
| 9 | | | |
| 8 | | | |
| 7 | | | |
| 6 | | | |
| 5 | | | |
| 4 | | | |
| 3 | | | |
| 2 | | | |
| 1 | D1001715 | S1001144 | +24@5A |

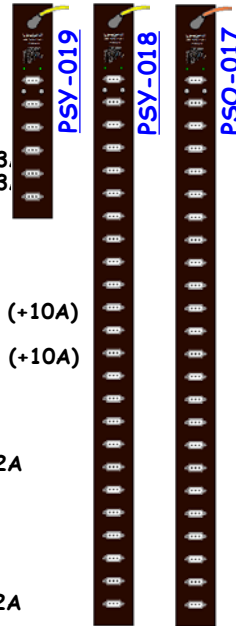

| | |
|--------|----|
| +18VDC | 9A |
| -18VDC | 9A |
| +24VDC | ?A |
| -24VDC | ?A |

HAMs 2&3 L1-SEI-C2

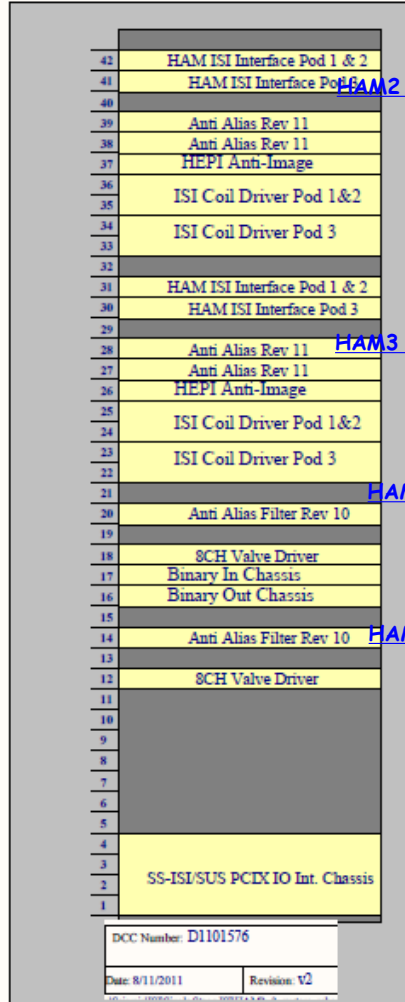

HAM2 ISI Interface Chassis
HAM2 ISI Interface Chassis

HAM2 ISI Anti-Alias Chassis
HAM2 ISI Anti-Alias Chassis
HAM2 HEPI Anti-Image Chassis

HAM2 ISI Coil Driver Pod 1 and Pod 2

HAM2 ISI Coil Driver Pod 3
ISI 2

HAM3 ISI Interface Chassis
HAM3 ISI Interface Chassis

HAM3 ISI Anti-Alias Chassis
HAM3 ISI Anti-Alias Chassis
HAM3 HEPI Anti-Image Chassis

HAM3 ISI Coil Driver Pod 1 and Pod 2

HAM3 ISI Coil Driver Pod 3
ISI 3

HAM2 HEPI Anti-Alias Chassis

HAM2 HEPI 8-Channel Valve Driver
Binary Input Chassis
Binary Output Chassis
HEPI 2

HAM3 HEPI Anti-Alias Chassis

HAM3 HEPI 8-Channel Valve Driver
HEPI 3

I/O Extension Chassis

| Dnumber | Serial |
|---------|----------|
| 42 | |
| 41 | |
| 40 | |
| 39 | S1104621 |
| 38 | S1104638 |
| 37 | S1104572 |
| 36 | S1103318 |
| 35 | |
| 34 | S1103332 |
| 33 | |
| 32 | |
| 31 | |
| 30 | |
| 29 | |
| 28 | S1104632 |
| 27 | S1104635 |
| 26 | S1104573 |
| 25 | S1103306 |
| 24 | |
| 23 | S1103304 |
| 22 | |
| 21 | |
| 20 | S1104616 |
| 19 | |
| 18 | S1000843 |
| 17 | S1101286 |
| 16 | S1101321 |
| 15 | |
| 14 | S1104615 |
| 13 | |
| 12 | S1000844 |
| 11 | |
| 10 | |
| 9 | |
| 8 | |
| 7 | |
| 6 | |
| 5 | |
| 4 | |
| 3 | |
| 2 | |
| 1 | |

- +18V@0.32A, -18V@0.33A
- +18V@0.32A, -18V@0.33A
- ±18@1A
- ±18@1A
- ±18@0.5A
- +24V@1.2A, -24V@0.8A
- +24V@1.2A, -24V@0.8A
- +18V@0.32A, -18V@0.33A
- +18V@0.32A, -18V@0.33A
- ±18@1A
- ±18@1A
- ±18@0.5A
- +24V@1.2A, -24V@0.8A (+10A)
- +24V@1.2A, -24V@0.8A (+10A)
- ±18@1A
- +18V@0.72A, -18V@0.72
- ±18@0.5A
- ±18@0.5A
- ±18@1A
- +18V@0.72A, -18V@0.72A
- +24@5A

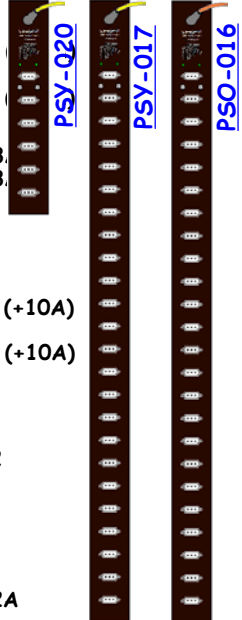

| | |
|--------|-----|
| +18VDC | 11A |
| -18VDC | 11A |
| +24VDC | ?A |
| -24VDC | ?A |

DCC Number: D1101576
Date: 8/11/2011 Revision: V2

HAMs 4&5 L1-SEI-C3

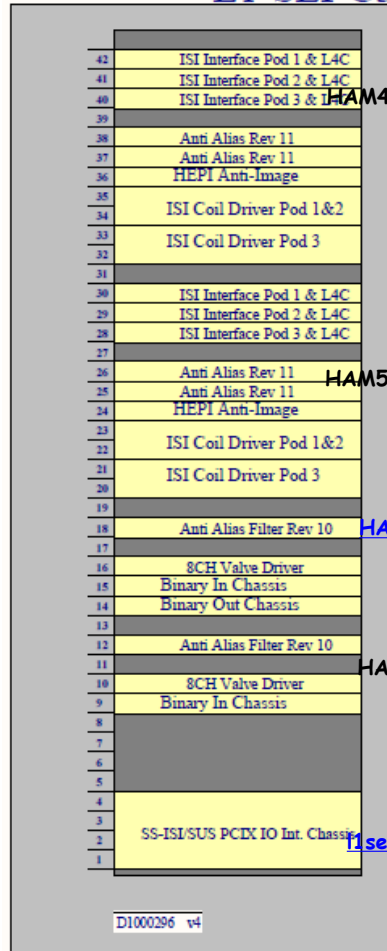

HAM4 ISI Interface Chassis
 HAM4 ISI Interface Chassis
 HAM4 ISI Interface Chassis
 HAM4 ISI Anti-Alias Chassis
 HAM4 ISI Anti-Alias Chassis
 HAM4 HEPI Anti-Image Chassis
 HAM4 ISI Coil Driver Pod 1 and Pod 2
 HAM4 ISI Coil Driver Pod 3
 HAM5 ISI Interface Chassis
 HAM5 ISI Interface Chassis
 HAM5 ISI Interface Chassis
 Anti-Alias Chassis
 Anti-Alias Chassis
 Anti-Image Chassis
 HAM5 ISI Coil Driver Pod 1 and Pod 2
 HAM5 ISI Coil Driver Pod 3
 Anti-Alias Chassis
 HAM4 HEPI 8-Channel Valve Driver
 HEPI Binary Input Chassis
 HEPI Binary Output Chassis
 Anti-Alias Chassis
 HAM5 HEPI 8-Channel Valve Driver
 HEPI Binary Input Chassis
 L1seiham4-5 - I/O Extension Chassis

| Front | | Rear | |
|-------|----------|------|----------|
| 42 | Dnumber | 42 | Serial |
| 41 | Dnumber | 41 | Serial |
| 40 | Dnumber | 40 | Serial |
| 39 | Dnumber | 39 | Serial |
| 38 | D1000269 | 38 | S1104621 |
| 37 | D1000269 | 37 | S1104638 |
| 36 | D1100202 | 36 | S1104572 |
| 35 | D0902744 | 35 | SN: |
| 34 | D0902744 | 34 | SN: |
| 33 | D0902744 | 33 | SN: |
| 32 | D0902744 | 32 | SN: |
| 31 | D0902744 | 31 | SN: |
| 30 | Dnumber | 30 | Serial |
| 29 | Dnumber | 29 | Serial |
| 28 | Dnumber | 28 | Serial |
| 27 | Dnumber | 27 | Serial |
| 26 | Dnumber | 26 | Serial |
| 25 | Dnumber | 25 | Serial |
| 24 | Dnumber | 24 | Serial |
| 23 | D0902744 | 23 | SN: |
| 22 | D0902744 | 22 | SN: |
| 21 | D0902744 | 21 | SN: |
| 20 | D0902744 | 20 | SN: |
| 19 | Dnumber | 19 | Serial |
| 18 | Dnumber | 18 | Serial |
| 17 | D020373 | 17 | S1000845 |
| 16 | Dxxxxxxx | 16 | SN: |
| 15 | Dxxxxxxx | 15 | SN: |
| 14 | Dxxxxxxx | 14 | SN: |
| 13 | Dnumber | 13 | Serial |
| 12 | Dnumber | 12 | Serial |
| 11 | D020373 | 11 | SN: |
| 10 | Dxxxxxxx | 10 | SN: |
| 9 | Dxxxxxxx | 9 | SN: |
| 8 | Dxxxxxxx | 8 | SN: |
| 7 | Dxxxxxxx | 7 | SN: |
| 6 | Dxxxxxxx | 6 | SN: |
| 5 | Dxxxxxxx | 5 | SN: |
| 4 | Dxxxxxxx | 4 | SN: |
| 3 | D1001715 | 3 | S1001146 |
| 2 | Dxxxxxxx | 2 | S1001146 |
| 1 | Dxxxxxxx | 1 | S1001146 |

+18V@0.32A, -18V@0.33A
 +18V@0.32A, -18V@0.33A
 +18V@0.32A, -18V@0.33A
 ±18@1A
 ±18@1A
 ±18@0.5A
 +24V@1.2A, -24V@0.8A
 +24V@1.2A, -24V@0.8A
 +18V@0.32A, -18V@0.33A
 +18V@0.32A, -18V@0.33A
 +18V@0.32A, -18V@0.33A
 ±18@1A
 ±18@1A
 ±18@0.5A
 +24V@1.2A, -24V@0.8A (+10A)
 +24V@1.2A, -24V@0.8A (+10A)
 ±18@1A
 +18V@0.72A, -18V@0.72A
 ±18@0.5A
 ±18@0.5A
 ±18@1A
 +18V@0.72A, -18V@0.72A
 ±18@0.5A

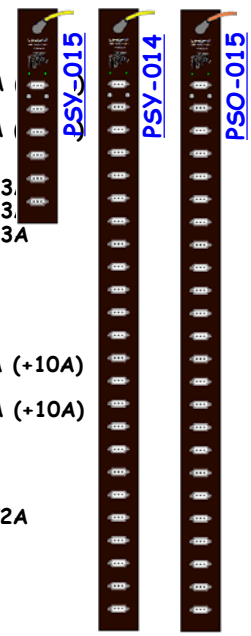

| | |
|--------|-----|
| +18VDC | 12A |
| -18VDC | 12A |
| +24VDC | ?A |
| -24VDC | ?A |

BSC1 L4C Interface Chassis

BSC1 ISI Interface Chassis Pod 1
 BSC1 ISI Interface Chassis Pod 2
 BSC1 ISI Interface Chassis Pod 3
 BSC1 L4C Interface Chassis

BSC1 BSC Anti-Alias Chassis
 Anti-Alias Chassis

Anti-Alias Chassis
 Anti-Alias Chassis
 Anti-Image Chassis

BSC1 HEPI 8-Channel Valve Driver

Binary Input Chassis
 Binary Input Chassis
 Binary Output Chassis

BSC1 T-240 Interface Chassis Pod 1

BSC1 T-240 Interface Chassis Pod 2

BSC1 T-240 Interface Chassis Pod 3

STX-2 Input /Distribution
l1seibsc1 - I/O Extension Chassis

Anti-Image Chassis

BSC1 ISI Coil Driver Pod 1

BSC1 ISI Coil Driver Pod 2

BSC1 ISI Coil Driver Pod 3

BSC 1,2,3,4&5

| | |
|----|---------------------------------|
| 42 | L4C Interface |
| 41 | |
| 40 | ISI Interface Pod 1 |
| 39 | ISI Interface Pod 2 |
| 38 | ISI Interface Pod 3 |
| 37 | L4C Interface |
| 36 | |
| 35 | Anti Alias Rev 12 |
| 34 | Anti Alias Rev 12 |
| 33 | |
| 32 | Anti Alias Rev 12 |
| 31 | |
| 30 | Anti Alias Rev 8 |
| 29 | AdL Anti-Image Chassis |
| 28 | |
| 27 | 8 CH VALVE DRIVER |
| 26 | |
| 25 | Binary Input Chassis |
| 24 | Binary Input Chassis |
| 23 | Binary Output Chassis |
| 22 | |
| 21 | T-240 Interface Pod 1 |
| 20 | T-240 Interface Pod 2 |
| 19 | T-240 Interface Pod 3 |
| 18 | |
| 17 | STX-2 Distribution Chassis |
| 16 | STX-2 Interface |
| 15 | Computer |
| 14 | |
| 13 | |
| 12 | ISI PCIX IO Interface Chassis 1 |
| 11 | |
| 10 | |
| 9 | |
| 8 | AdL Anti-Image Chassis |
| 7 | |
| 6 | |
| 5 | ISI Coil Driver Pod 1 |
| 4 | ISI Coil Driver Pod 2 |
| 3 | |
| 2 | ISI Coil Driver Pod 3 |
| 1 | |

DCC Number: LIGO-D0901301

Date: 6/3/2011 Revision: V4

| | | | | |
|--|----------|----|----------|--|
| | Dnumber | 42 | Serial | |
| | Dnumber | 41 | Serial | |
| | Dnumber | 40 | Serial | |
| | Dnumber | 39 | Serial | |
| | Dnumber | 38 | Serial | |
| | Dnumber | 37 | Serial | |
| | Dnumber | 36 | Serial | |
| | Dnumber | 35 | Serial | |
| | D1002693 | 34 | Serial | |
| | Dnumber | 33 | Serial | |
| | Dnumber | 32 | Serial | |
| | Dnumber | 31 | Serial | |
| | Dnumber | 30 | Serial | |
| | Dnumber | 29 | Serial | |
| | Dnumber | 28 | Serial | |
| | D020373 | 27 | SN: | |
| | Dnumber | 26 | SN: | |
| | Dxxxxxxx | 25 | SN: | |
| | Dxxxxxxx | 24 | SN: | |
| | Dxxxxxxx | 23 | SN: | |
| | Dxxxxxxx | 22 | SN: | |
| | Dnumber | 21 | Serial | |
| | Dnumber | 20 | Serial | |
| | Dnumber | 19 | Serial | |
| | Dnumber | 18 | Serial | |
| | Dnumber | 17 | Serial | |
| | Dnumber | 16 | Serial | |
| | Dnumber | 15 | Serial | |
| | Dnumber | 14 | Serial | |
| | Dnumber | 13 | Serial | |
| | D1001715 | 12 | S1001147 | |
| | Dnumber | 11 | Serial | |
| | Dnumber | 10 | Serial | |
| | Dnumber | 9 | Serial | |
| | Dnumber | 8 | Serial | |
| | Dnumber | 7 | Serial | |
| | D0902744 | 6 | SN: | |
| | D0902744 | 5 | SN: | |
| | D0902744 | 4 | SN: | |
| | D0902744 | 3 | SN: | |
| | D0902744 | 2 | SN: | |
| | D0902744 | 1 | SN: | |
| | Front | | Rear | |

+18V@0.32A, -18V@0.33A

+18V@0.32A, -18V@0.33A
 +18V@0.32A, -18V@0.33A
 +18V@0.32A, -18V@0.33A
 +18V@0.32A, -18V@0.33A

±18@1A
 ±18@1A

±18@1A

±18@1A
 ±18@0.5A

+18V@0.72A, -18V@0.72A

±18@0.5A
 ±18@0.5A

±18@0.5A

+18V@0.32A, -18V@0.33A

+18V@0.32A, -18V@0.33A

+18V@0.32A, -18V@0.33A

+24@5A

±18@0.5A

+24V@1.2A, -24V@0.8A (+10A)

+24V@1.2A, -24V@0.8A (+10A)

+24V@1.2A, -24V@0.8A (+10A)

| | |
|--------|-----|
| +18VDC | 10A |
| -18VDC | 10A |
| +24VDC | ?A |
| -24VDC | ?A |

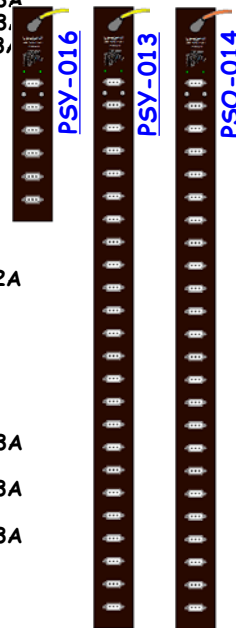

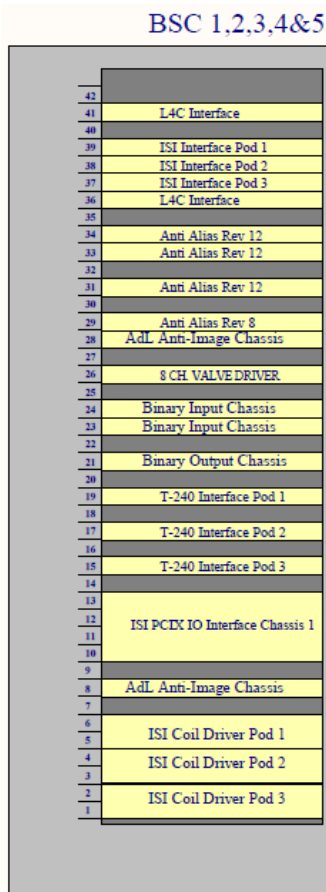

BSC3 L4C Interface Chassis
 BSC3 ISI Interface Chassis Pod 1
 BSC3 ISI Interface Chassis Pod 2
 BSC3 ISI Interface Chassis Pod 3
 BSC3 L4C Interface Chassis

Anti-Alias Chassis
 Anti-Alias Chassis
 Anti-Alias Chassis
 Anti-Alias Chassis
 Anti-Image Chassis

BSC3 HEPI 8-Channel Valve Driver

Binary Input Chassis
 Binary Input Chassis
 AdL Anti-Image Chassis
 8 CH VALVE DRIVER
 Binary Output Chassis

BSC3 T-240 Interface Chassis Pod 1
 BSC3 T-240 Interface Chassis Pod 2
 BSC3 T-240 Interface Chassis Pod 3

[I1seibsc3 - I/O Extension Chassis](#)

Anti-Image Chassis

BSC3 ISI Coil Driver Pod 1
 BSC3 ISI Coil Driver Pod 2
 BSC3 ISI Coil Driver Pod 3

| | | | |
|--------------------------|----|--------------------------|--|
| | 42 | | |
| Dnumber | 41 | Serial | |
| | 40 | | |
| Dnumber | 39 | Serial | |
| Dnumber | 38 | Serial | |
| Dnumber | 37 | Serial | |
| Dnumber | 36 | Serial | |
| | 35 | | |
| Dnumber | 34 | Serial | |
| Dnumber | 33 | Serial | |
| | 32 | | |
| Dnumber | 31 | Serial | |
| Dnumber | 30 | | |
| Dnumber | 29 | Serial | |
| Dnumber | 28 | Serial | |
| | 27 | | |
| D020373 | 26 | SN: | |
| | 25 | | |
| Dxxxxxxx | 24 | SN: | |
| Dxxxxxxx | 23 | SN: | |
| | 22 | | |
| Dxxxxxxx | 21 | SN: | |
| | 20 | | |
| Dnumber | 19 | Serial | |
| | 18 | | |
| Dnumber | 17 | Serial | |
| | 16 | | |
| Dnumber | 15 | Serial | |
| | 14 | | |
| | 13 | | |
| D1001715 | 12 | S1100946 | |
| | 11 | | |
| | 10 | | |
| Dnumber | 9 | Serial | |
| | 8 | | |
| | 7 | | |
| D0902744 | 6 | SN: | |
| | 5 | | |
| D0902744 | 4 | SN: | |
| | 3 | | |
| D0902744 | 2 | SN: | |
| | 1 | | |
| Front | | Rear | |

+18V@0.32A, -18V@0.33A
 +18V@0.32A, -18V@0.33A
 +18V@0.32A, -18V@0.33A
 +18V@0.32A, -18V@0.33A
 +18V@0.32A, -18V@0.33A

±18@1A
 ±18@1A

±18@1A

±18@1A
 ±18@0.5A

+18V@0.72A, -18V@0.72A

±18@0.5A
 ±18@0.5A

±18@0.5A

+18V@0.32A, -18V@0.33A

+18V@0.32A, -18V@0.33A

+18V@0.32A, -18V@0.33A

+24@5A

±18@0.5A

+24V@1.2A, -24V@0.8A (+10A)

+24V@1.2A, -24V@0.8A (+10A)

+24V@1.2A, -24V@0.8A (+10A)

| | |
|--------|-----|
| +18VDC | 10A |
| -18VDC | 10A |
| +24VDC | ?A |
| -24VDC | ?A |

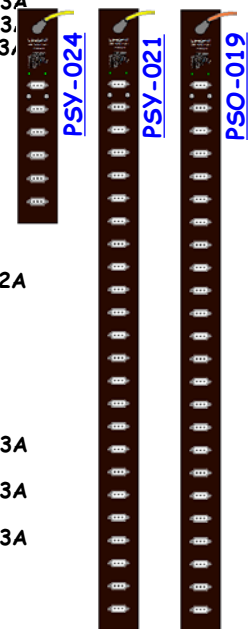

L1-SEI-C1 Details

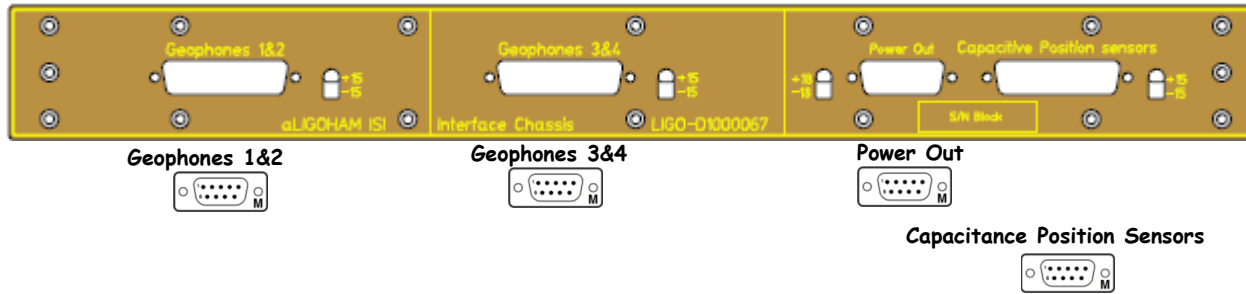

[D1000067](#)

Front

Sxxxxxxx

Rear

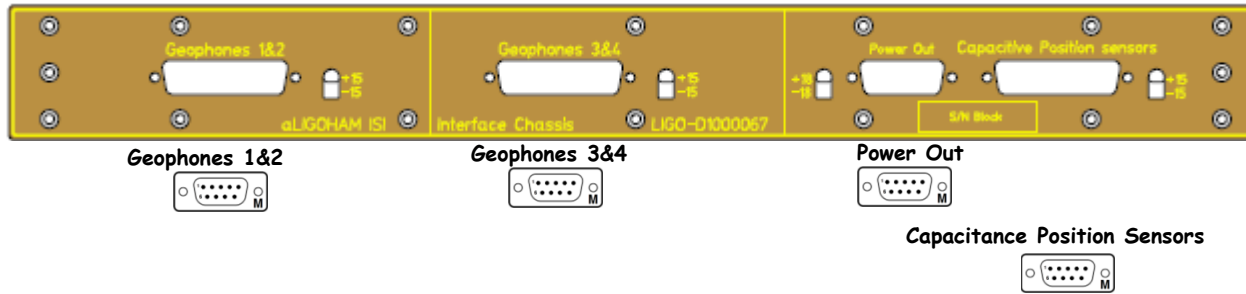

[D1000067](#)

Front

Sxxxxxxx

Rear

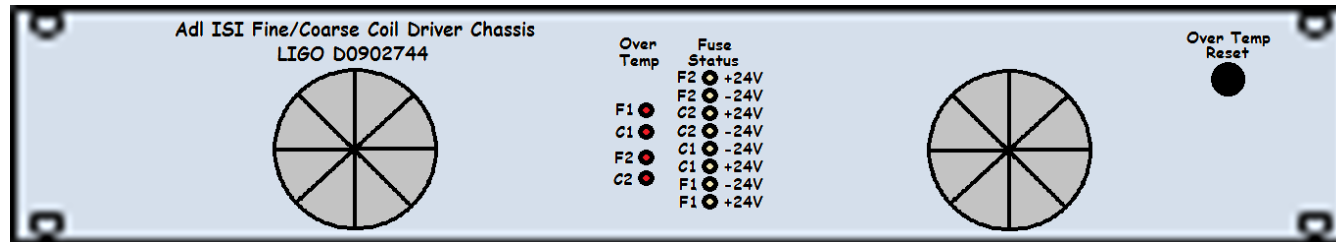

D0902744

Front

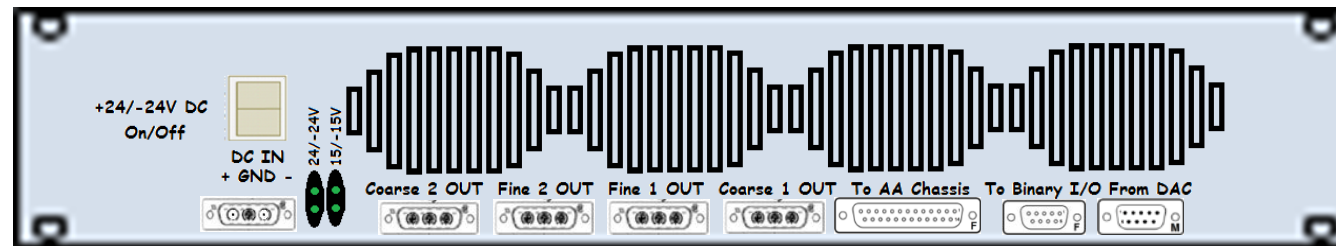

Sxxxxxxx

Rear

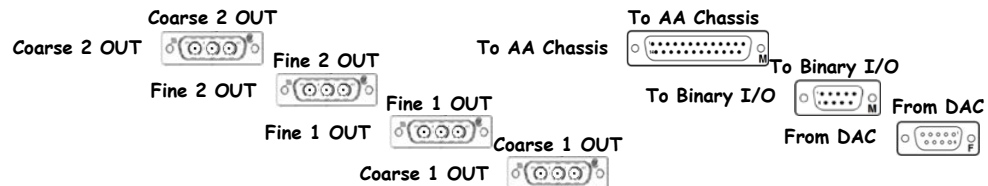

<< L1-SEI-C1

HAM6 ISI Coil Driver Pod 1 and Pod 2

D0902744

Sxxxxxxx

+24V@1.2A, -24V@0.8A (+10A)

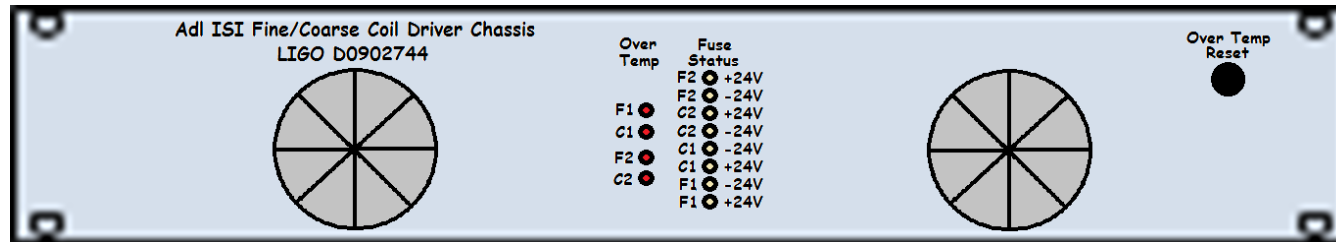

D0902744

Front

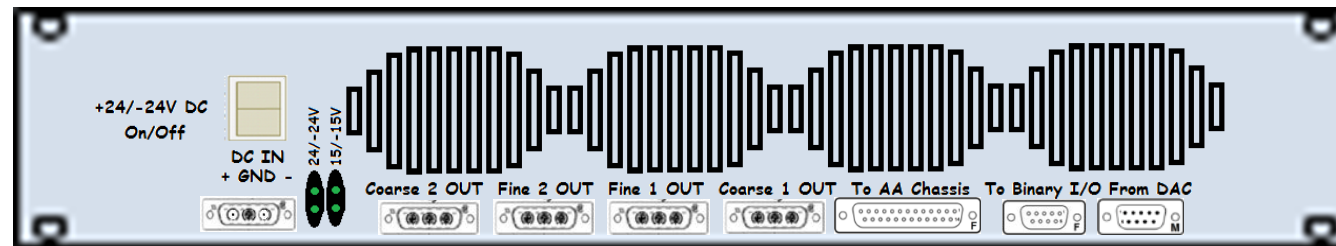

Sxxxxxxx

Rear

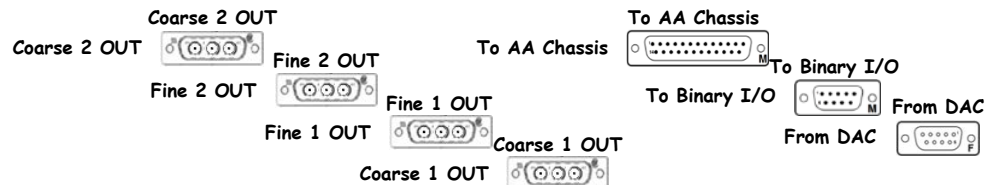

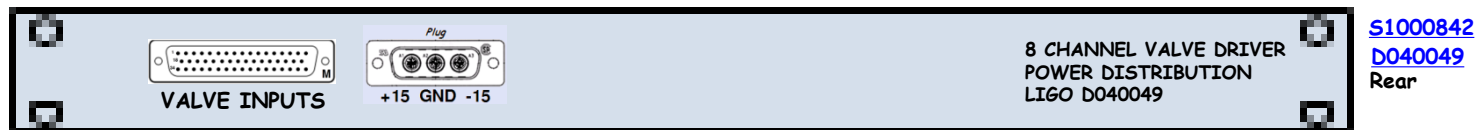
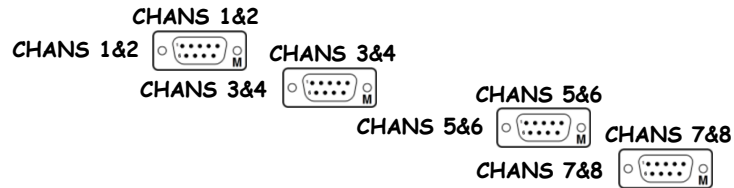
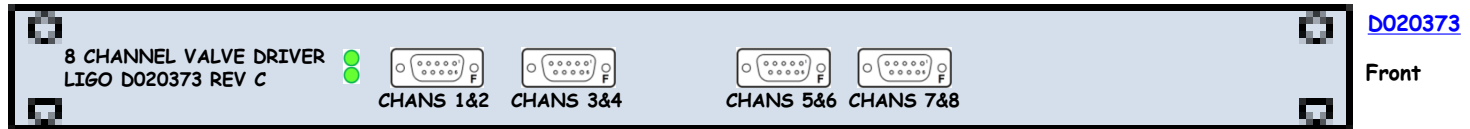

<< L1-SEI-C1

HEPI6 8-Channel Valve Driver Power

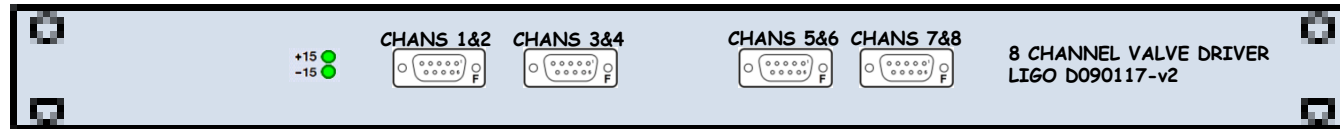
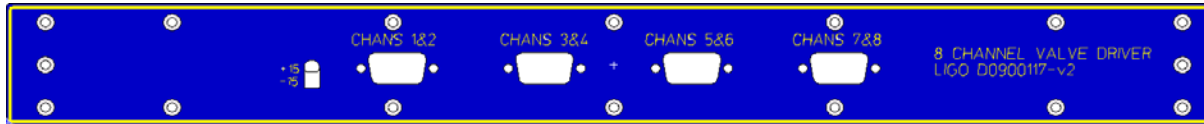

D0901338

Front

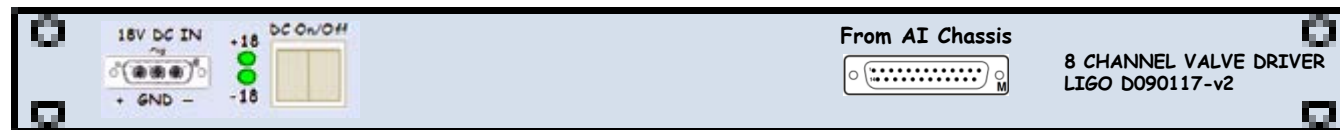
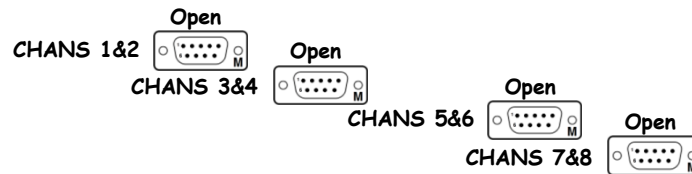

SN:

Rear





D1001715

Front

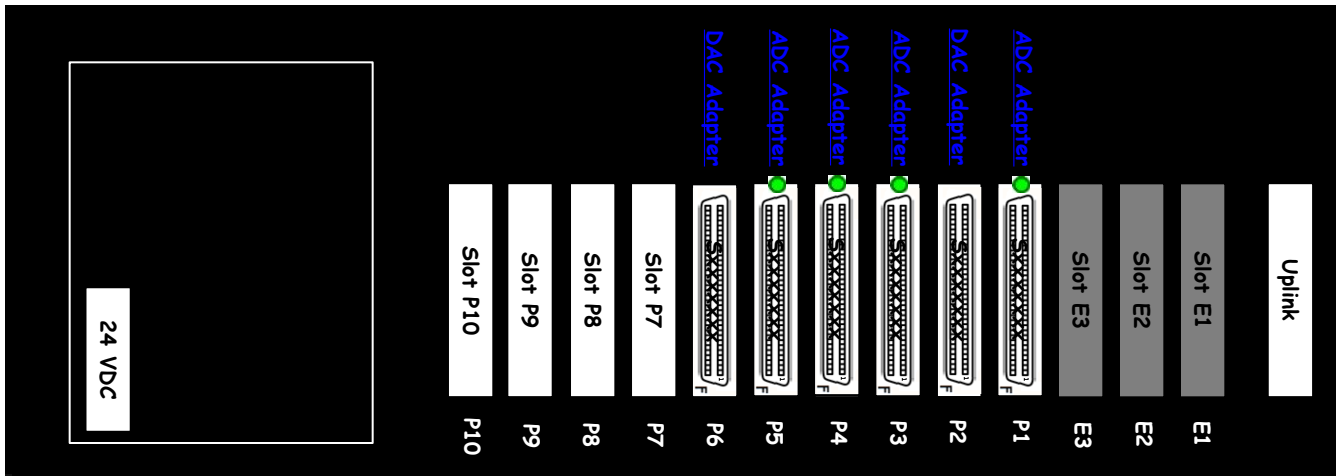

S1001144

Rear

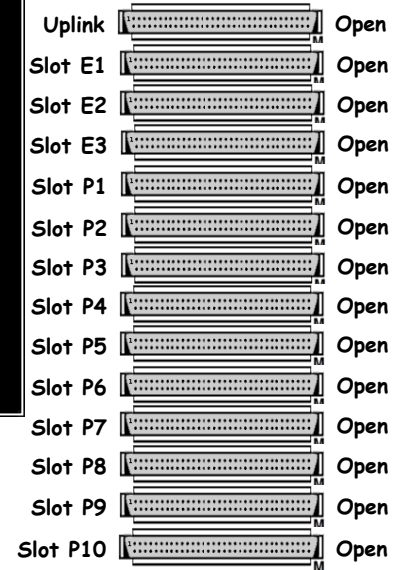



SEI Racks L1-SEI-01

L1-SEI-01
Front

Dxxxxxx ISI IF Chassis
 Dxxxxxx ISI IF Chassis
 Dxxxxxx ISI IF Chassis
 D0902783 AA Chassis
 D0902783 AA Chassis
 D0902783 AA Chassis
 Dxxxxxx BO Chassis
 Dxxxxxx BO Chassis
 Dxxxxxx BI Chassis
 Dxxxxxx BI Chassis

D0902783 AA Chassis
 D1000305 AI Chassis
 Dxxxxxx 8 Valve Chassis
 Dxxxxxx BO Chassis
 Dxxxxxx BI Chassis

Dxxxxxx T240 IF Chassis
 Dxxxxxx T240 IF Chassis
 Dxxxxxx T240 IF Chassis

I/O Extension
 4 ADC
 2 DAC
 4 Binary

D1000305 AI Chassis
 Dxxxxxx ISI Coil Chassis
 Dxxxxxx ISI Coil Chassis
 Dxxxxxx ISI Coil Chassis

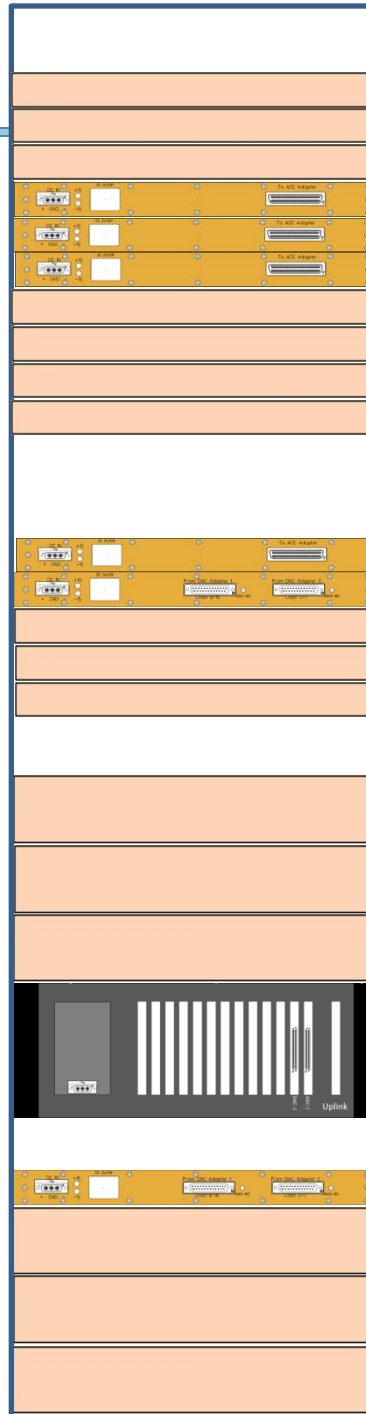
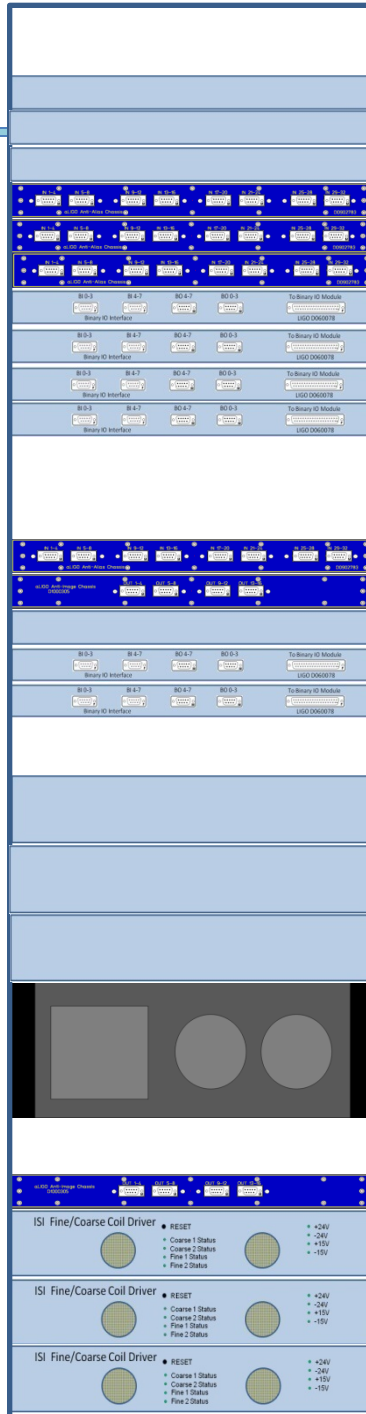

D0902783 SYYYYYYYY
 D0902783 SYYYYYYYY
 D0902783 SYYYYYYYY

D0902783 SYYYYYYYY
 D1000305 SYYYYYYYY

D1000305 SYYYYYYYY

L1-SEI-01
Rear

| | |
|----|------------------------------------|
| 1 | Tuning Slave |
| 2 | |
| 3 | ISI Interface Pod 1 |
| 4 | ISI Interface Pod 2 |
| 5 | ISI Interface Pod 3 |
| 6 | |
| 7 | Ann Alias Rev 12 |
| 8 | Ann Alias Rev 12 |
| 9 | |
| 10 | Ann Alias Rev 12 |
| 11 | Ann Alias Rev 8 HEPI |
| 12 | |
| 13 | Binary In/Out Chassis |
| 14 | Binary In/Out Chassis |
| 15 | |
| 16 | AdL Anti-Image Chassis HEPI |
| 17 | |
| 18 | 8 CH VALVE DRIVER HEPI |
| 19 | Binary I/O Chassis HEPI |
| 20 | |
| 21 | T-240 Interface Pod 1 |
| 22 | T-240 Interface Pod 2 |
| 23 | T-240 Interface Pod 3 |
| 24 | |
| 25 | |
| 26 | |
| 27 | |
| 28 | |
| 29 | |
| 30 | ISI PCIX IO Interface Chassis 1 |
| 31 | |
| 32 | ISI Control CPU |
| 33 | |
| 34 | AdL Anti-Image Chassis |
| 35 | |
| 36 | ISI Coil Driver Pod 1 |
| 37 | ISI Coil Driver Pod 2 |
| 38 | ISI Coil Driver Pod 2 |
| 39 | |
| 40 | ISI Coil Driver Pod 3 |
| 41 | |
| 42 | |
| 43 | |
| 44 | |
| 45 | |

LIGO-D0601301

L1-SEI-C2 Details

HAM2 ISI Anti-Alias Chassis D1000269 S1104621 ±18@1A

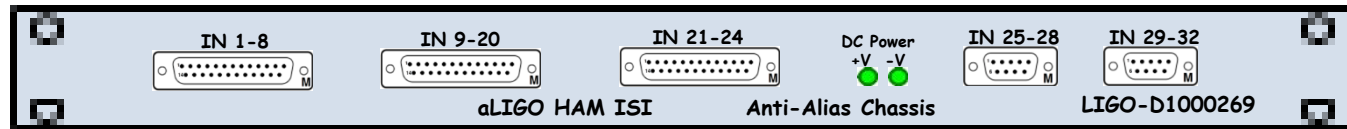

[D1000269](#)

Front

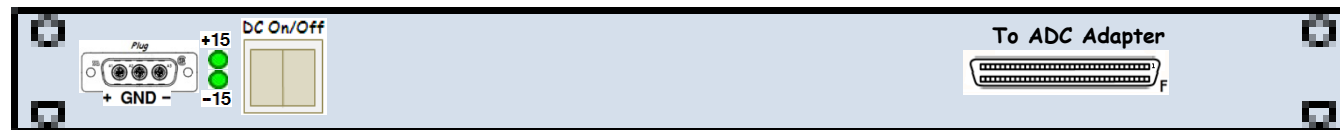
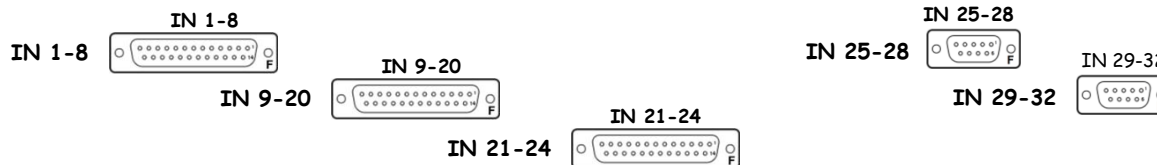

[S1104621](#)

Rear



HAM2 ISI Anti-Alias Chassis D1000269 S1104638 ±18@1A

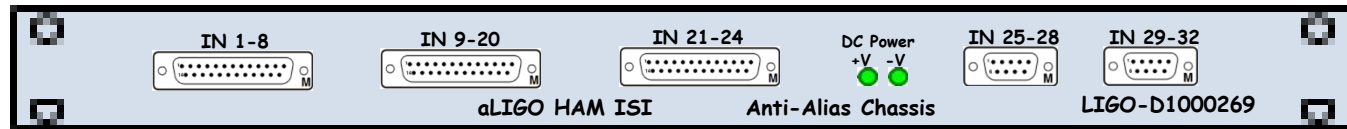

[D1000269](#)

Front

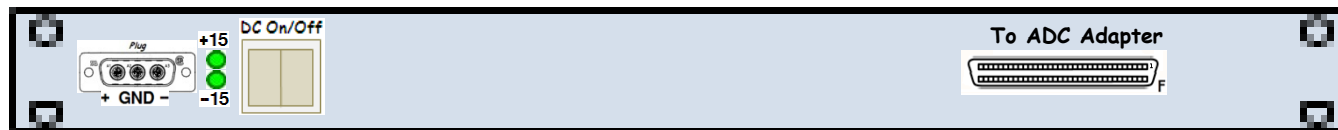
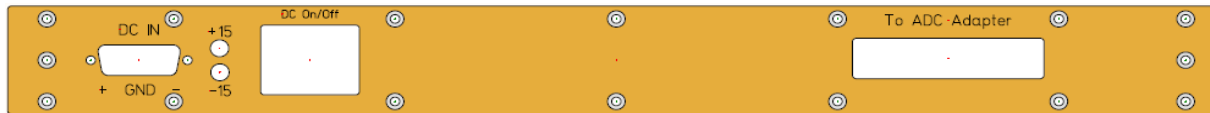
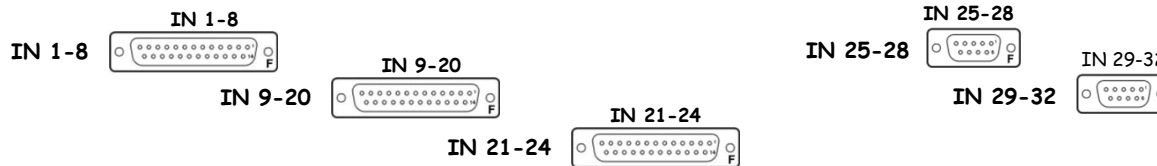

[S1104638](#)

Rear



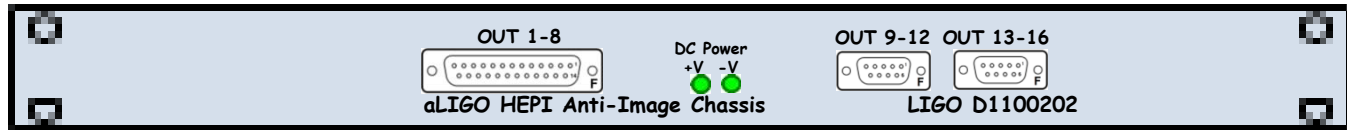

[D1100202](#)

Front

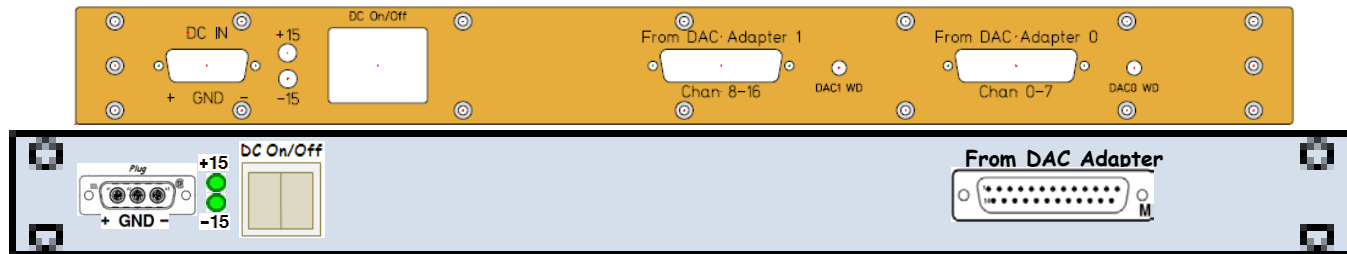

[S1104572](#)

Rear



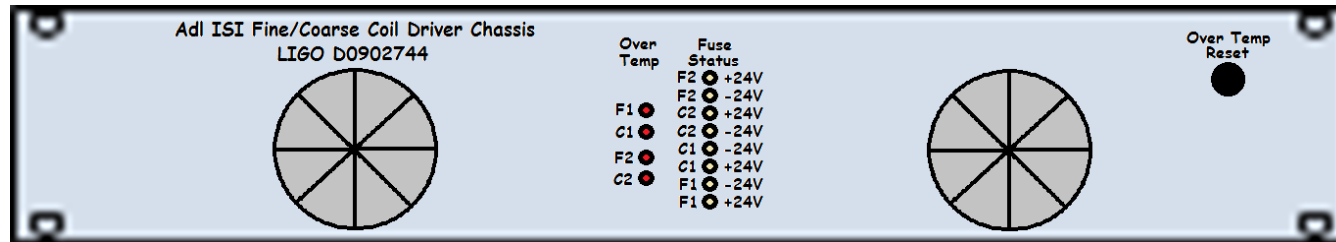

D0902744

Front

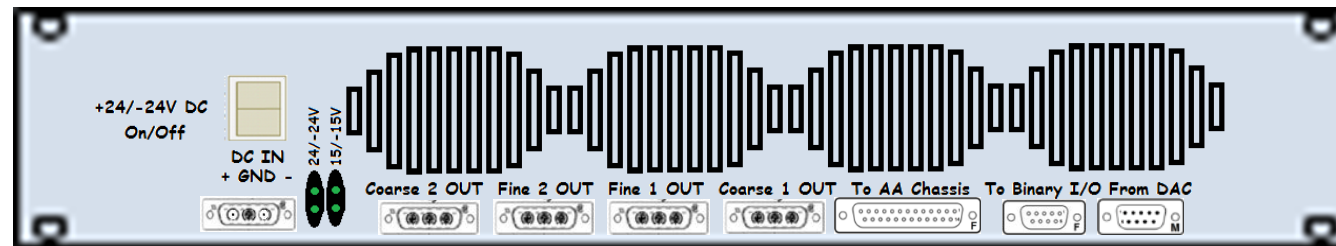

S1103332

Rear

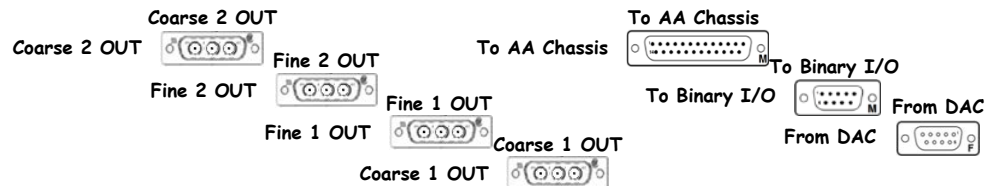

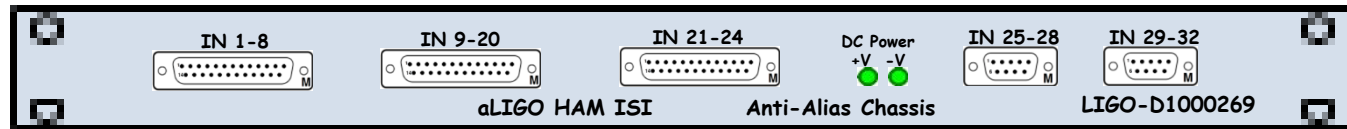

[D1000269](#)

Front

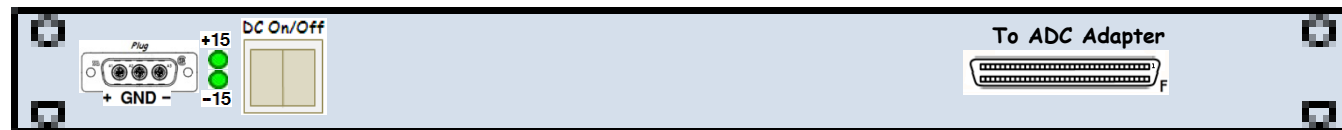
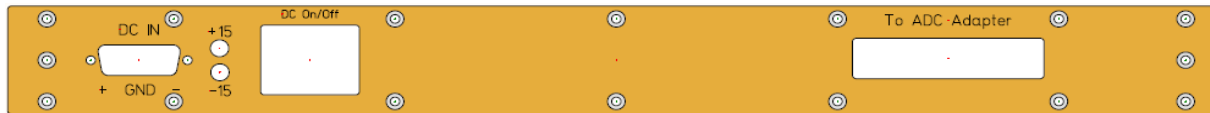
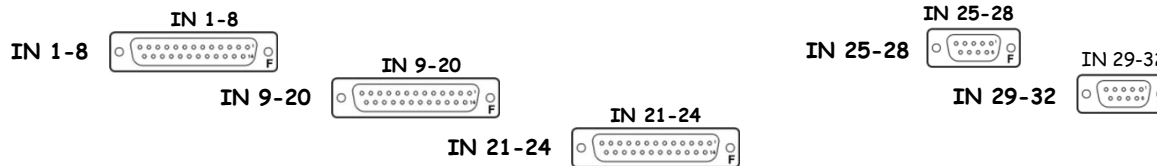

[S1104632](#)

Rear



HAM3 ISI Anti-Alias Chassis D1000269 S1104635 ±18@1A

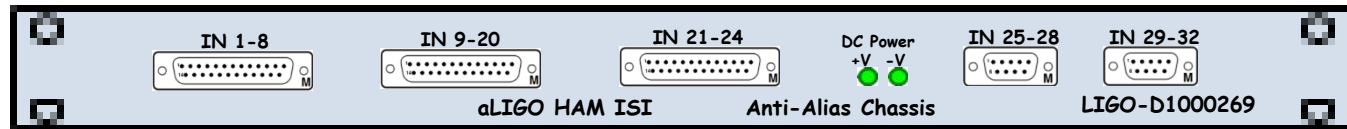

[D1000269](#)

Front

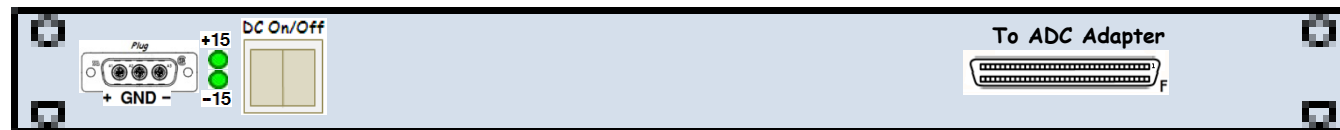
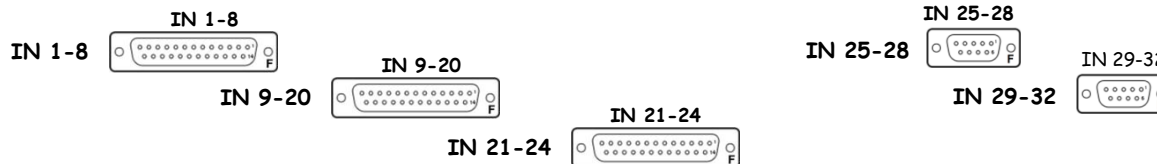

[S1104635](#)

Rear



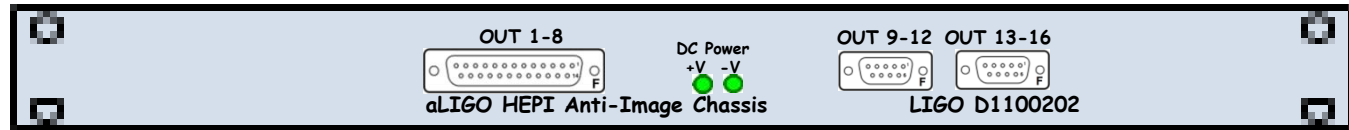

[D1100202](#)

Front

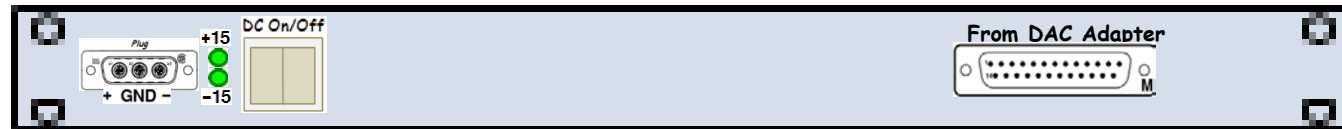
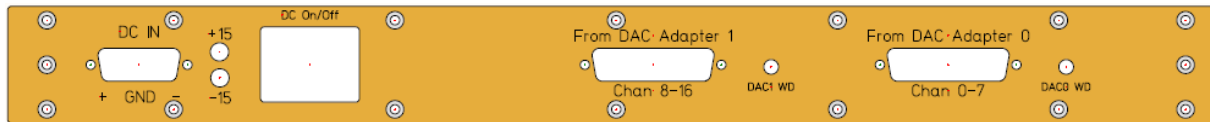

[S1104573](#)

Rear



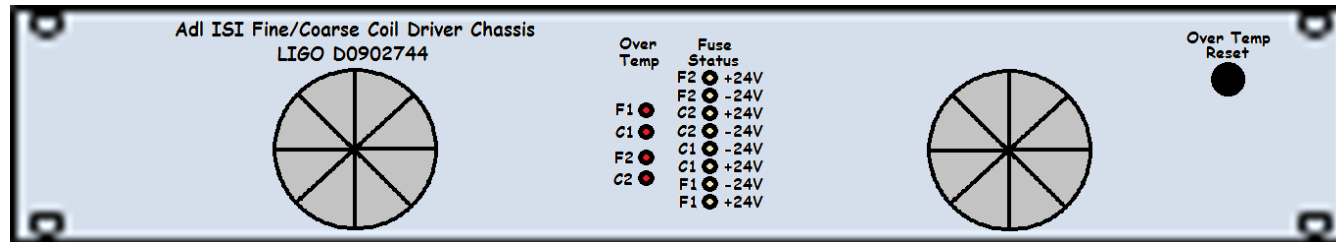

D0902744

Front

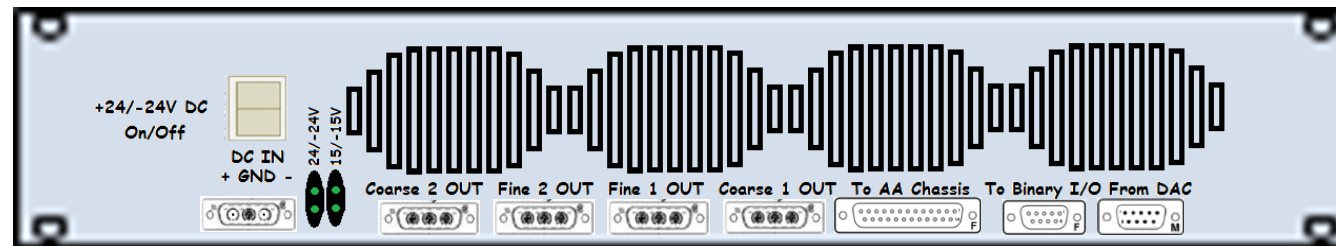

S1103306

Rear

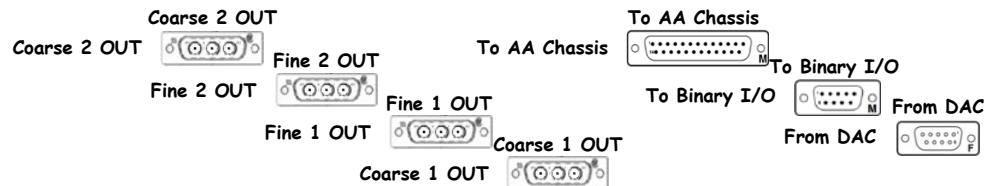

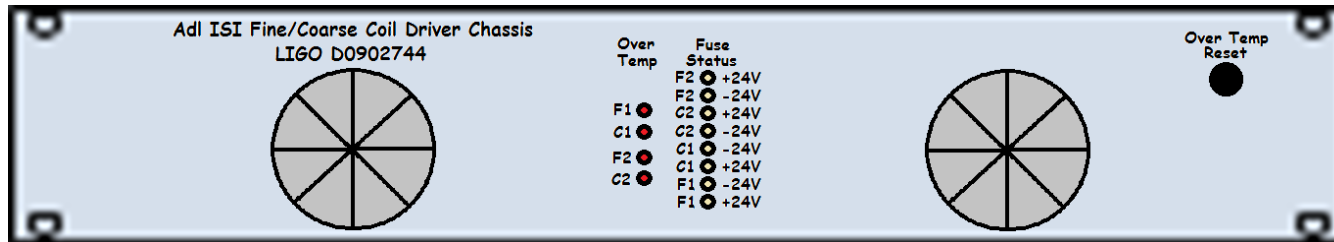

D0902744

Front

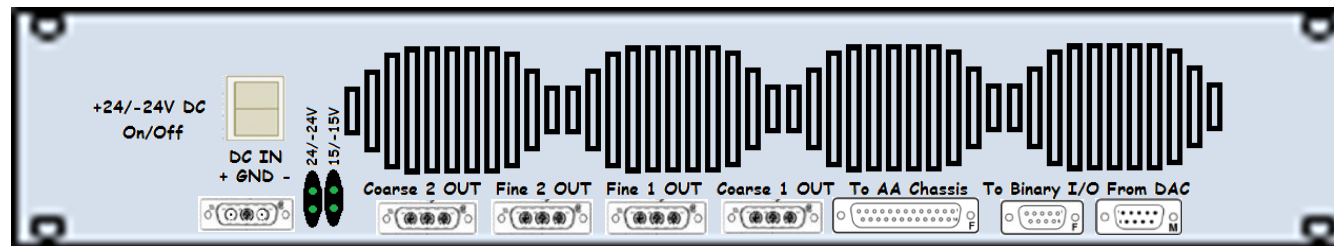

S1103304

Rear

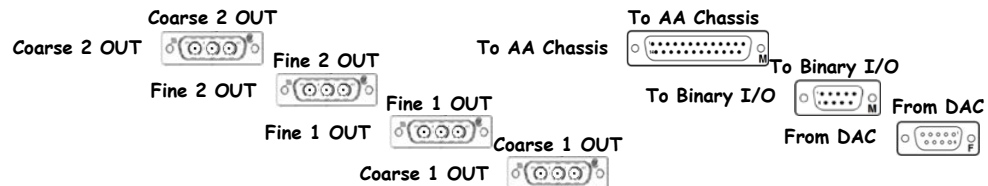

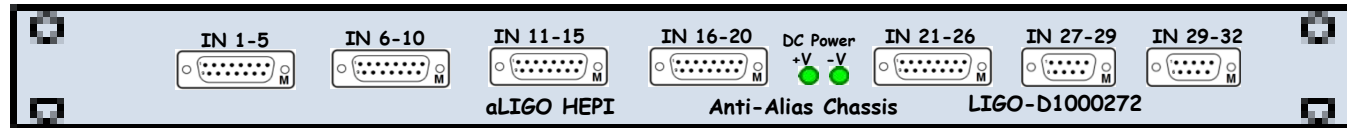
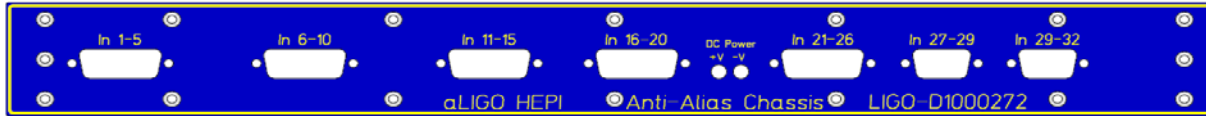

D1000269

Front

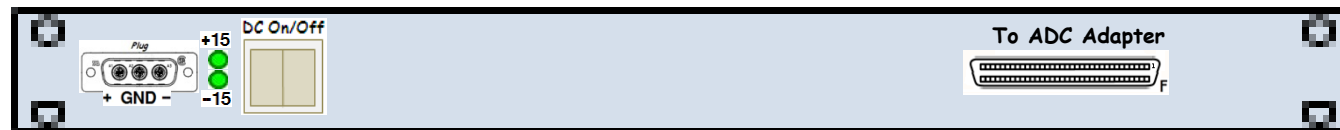
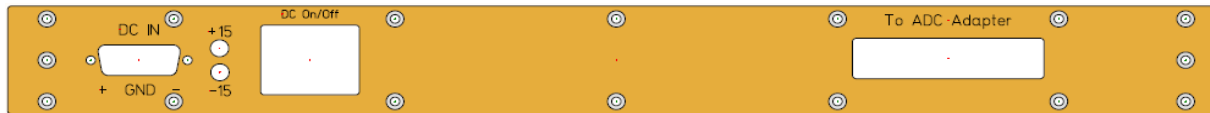
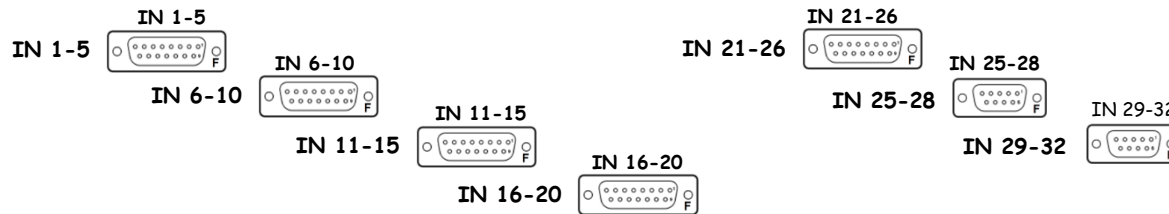

S1104616

Rear



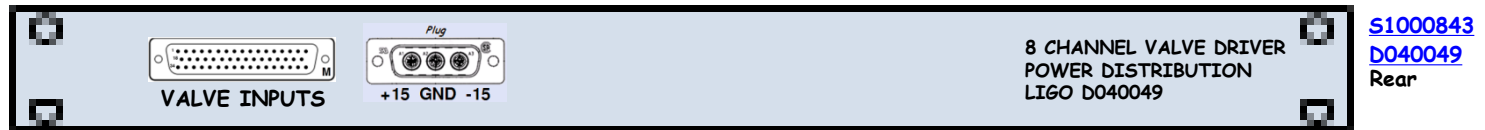
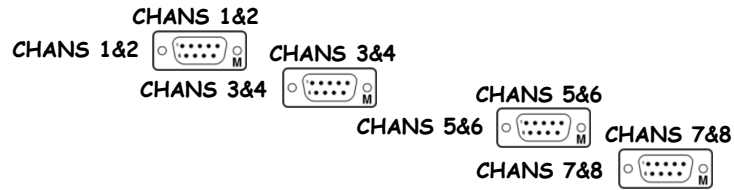
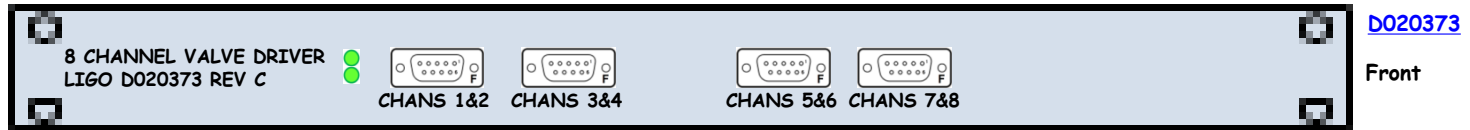

Binary Input Chassis D1001726 S1101286 ±18@0.5A

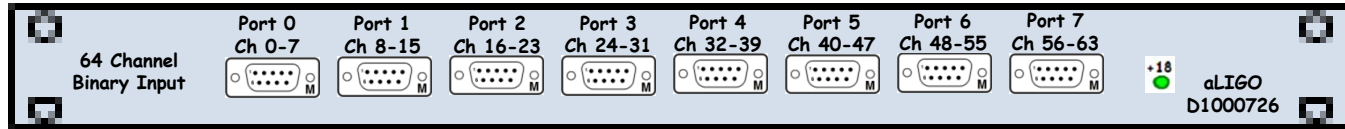
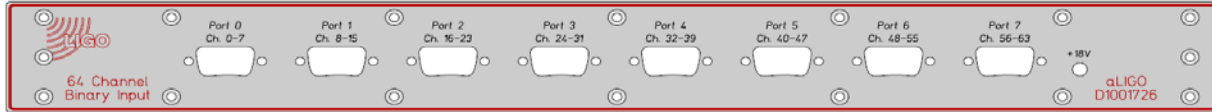

[D1001726](#)

Front

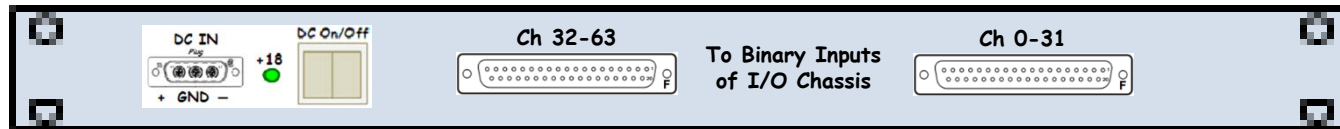
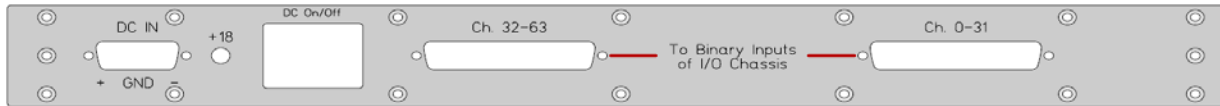
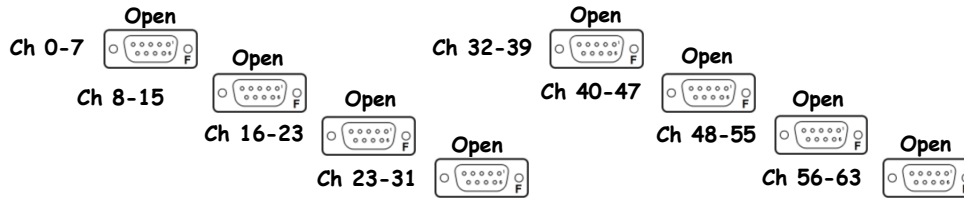

[S1101286](#)

Rear



Binary Output Chassis D1001728 S1101321 ±18@0.5A

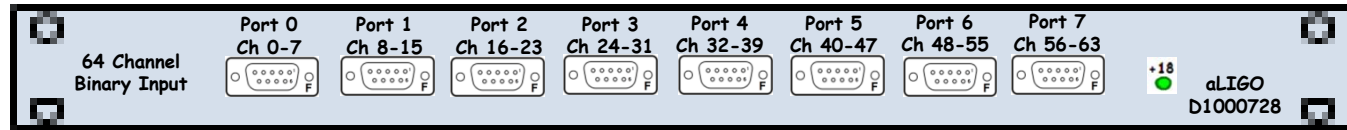
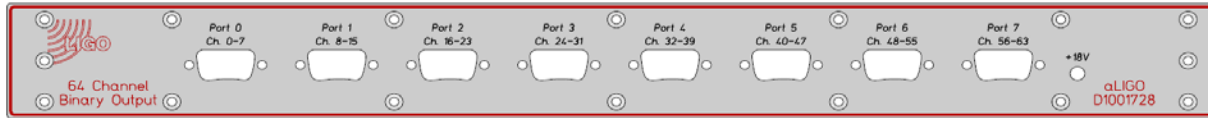

[D1001728](#)

Front

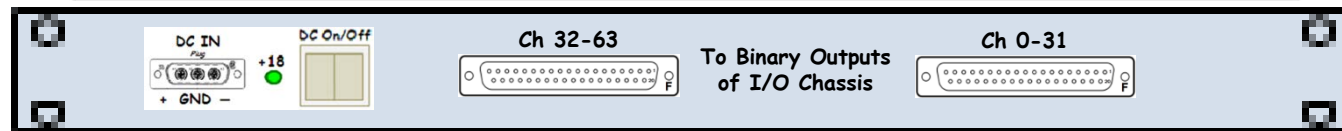
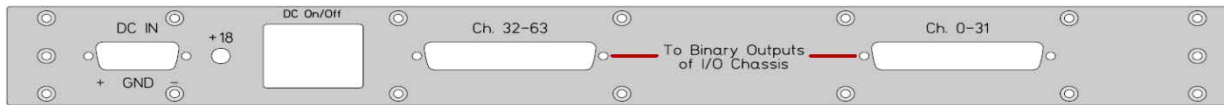
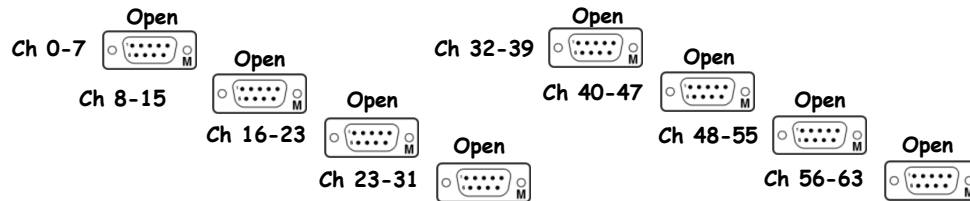

[S1101321](#)

Rear



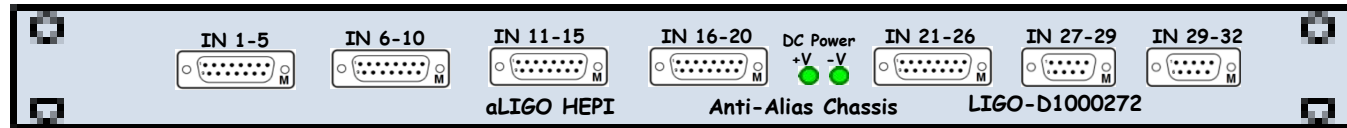
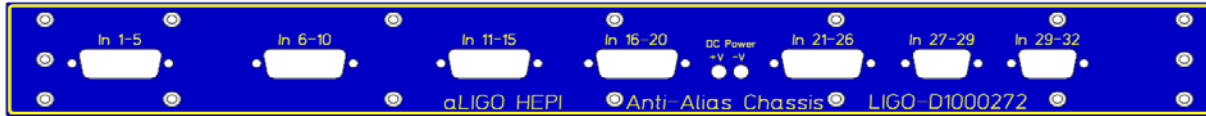

D1000269

Front

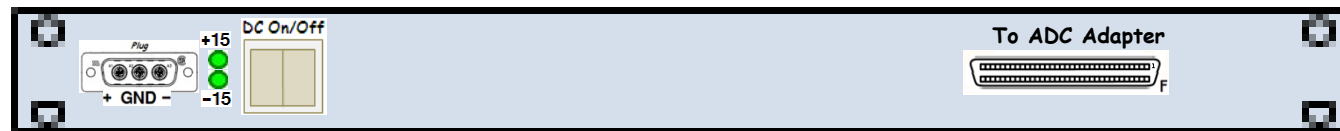
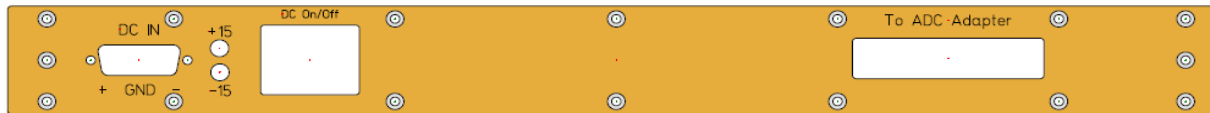
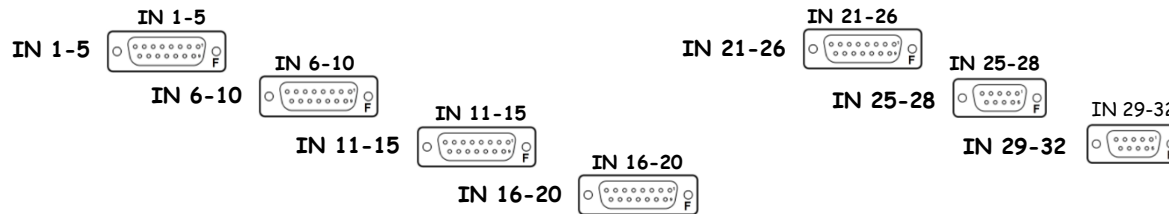

S1101321

Rear



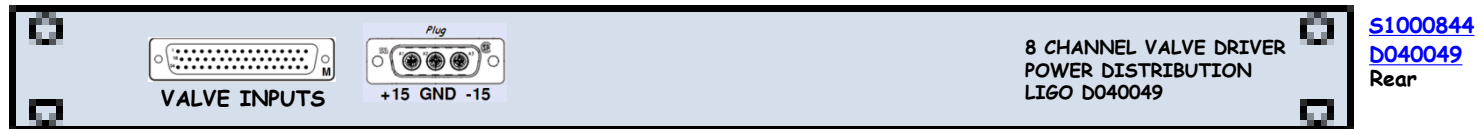
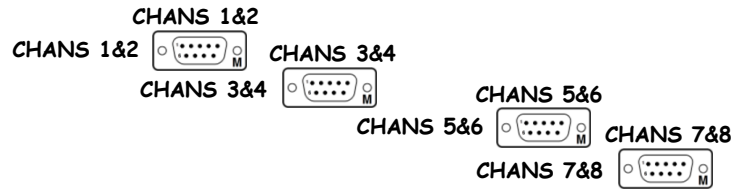
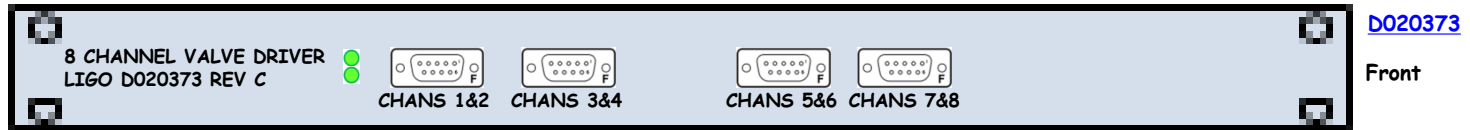

D1001715 - S1001145

I1seiham2-3 - I/O Extension Chassis

D1001715

S1001145

24 VDC



D1001715

Front

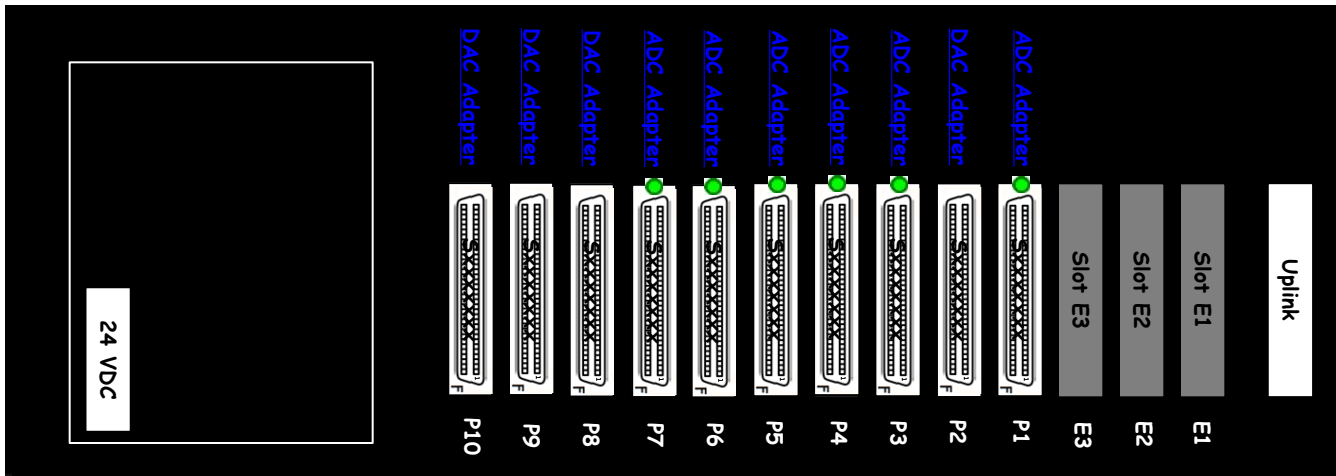

S1001145

Rear

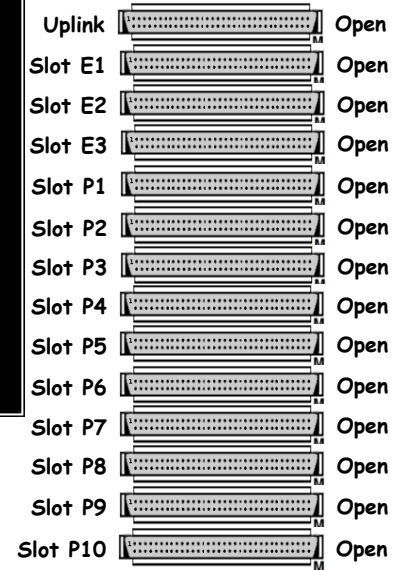

L1-SEI-C3 Details

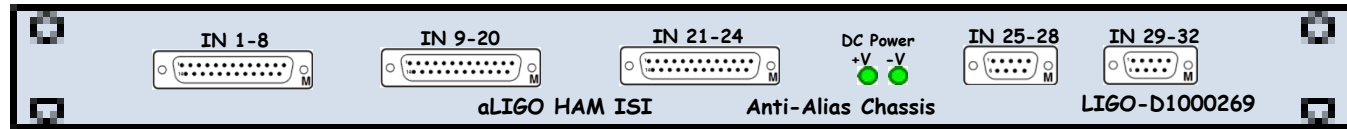

[D1000269](#)

Front

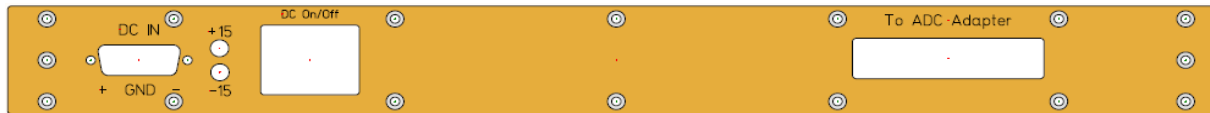
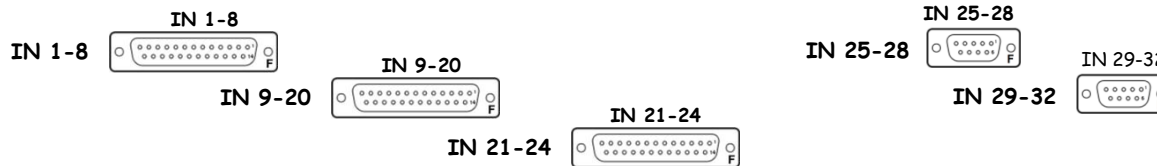

[S1104621](#)

Rear



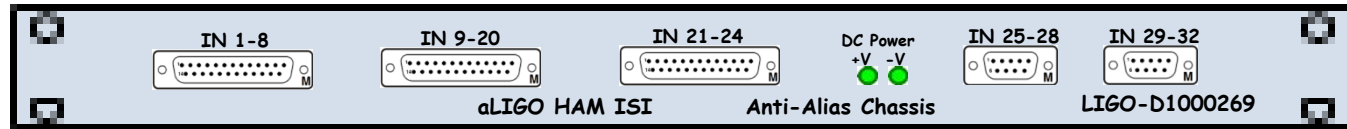

[D1000269](#)

Front

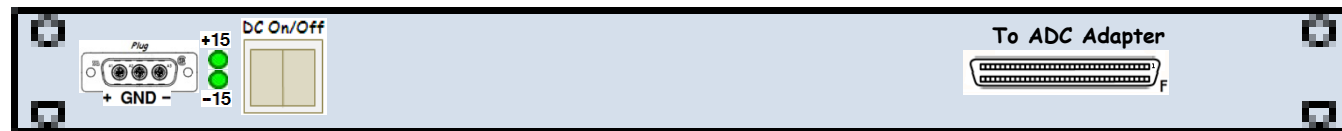
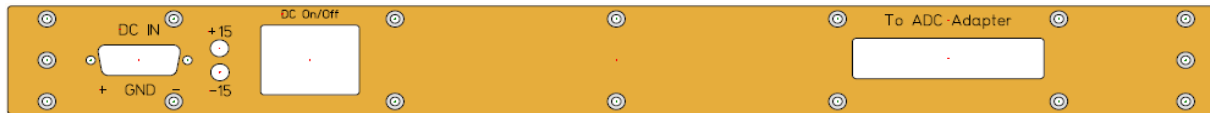
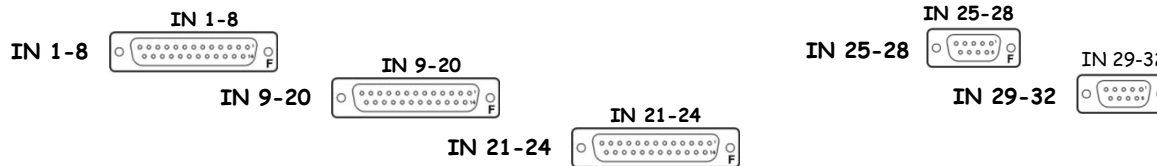

[S1104638](#)

Rear



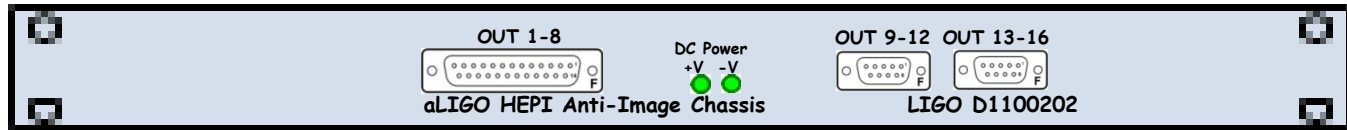

[D1100202](#)

Front

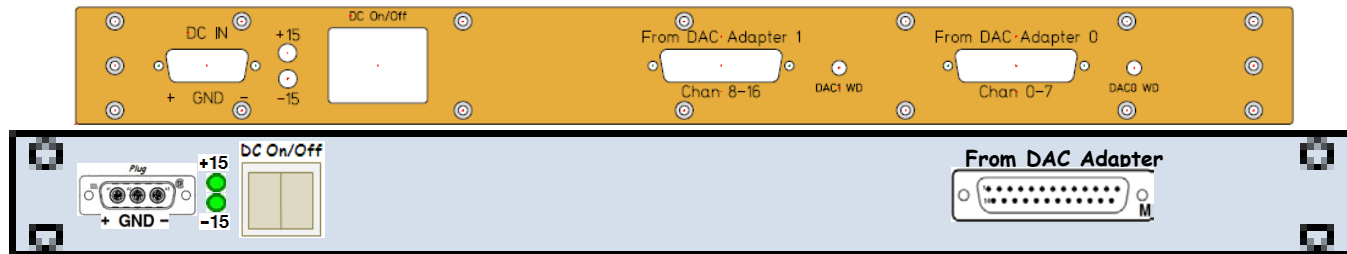

[S1104572](#)

Rear



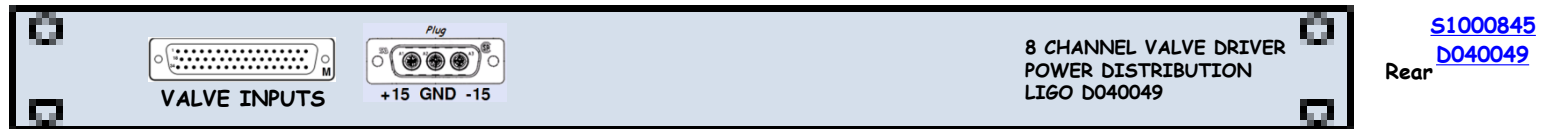
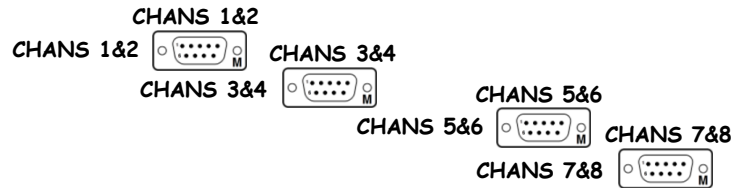
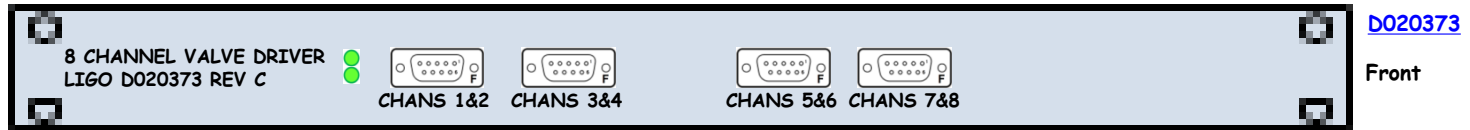

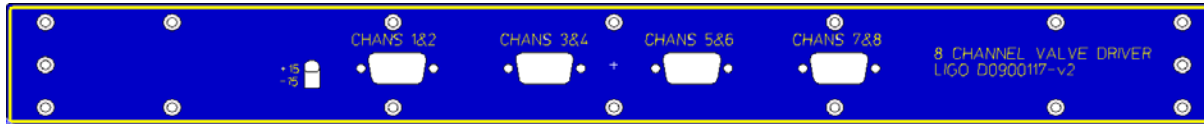

[D0901338](#)

Front

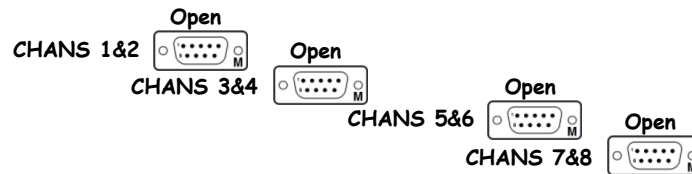

SN:

Rear





S1001146

Front

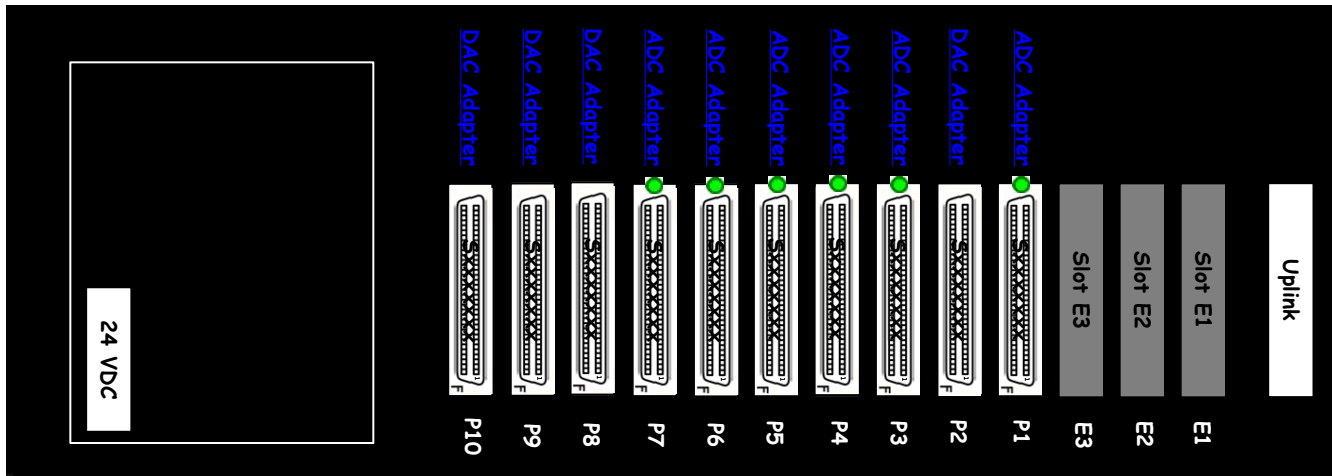

S1001146

Rear

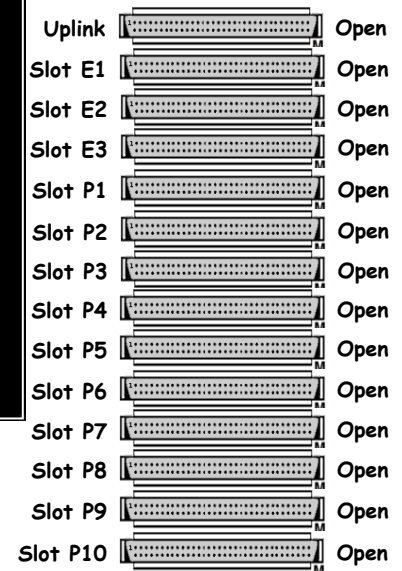

L1-SEI-C4 Details

<< L1-SEI-C4

BSC1 BSC Anti-Alias Chassis D1002693 Sxxxxxxx ±18@1A

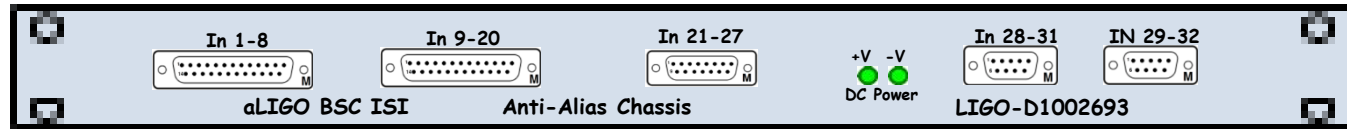

D1002693

Front

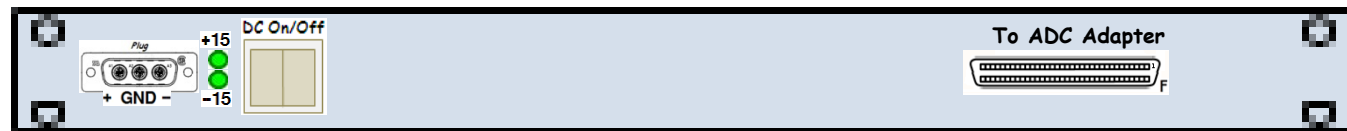
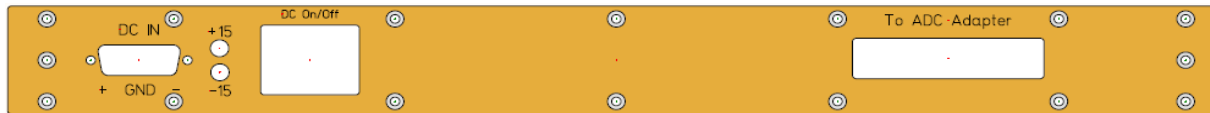
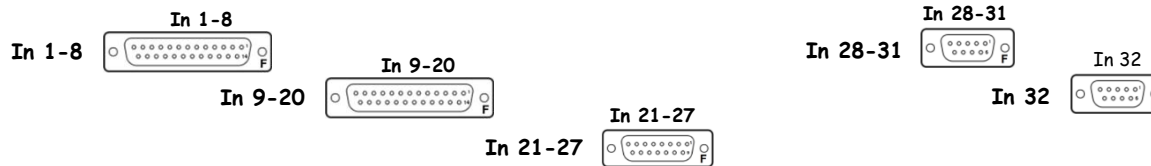

Sxxxxxxx

Rear



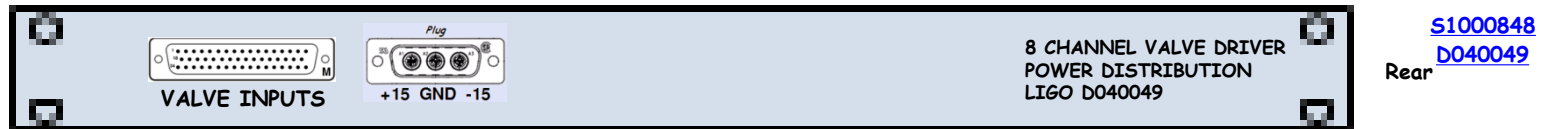
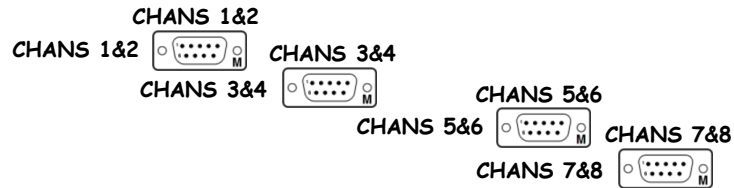
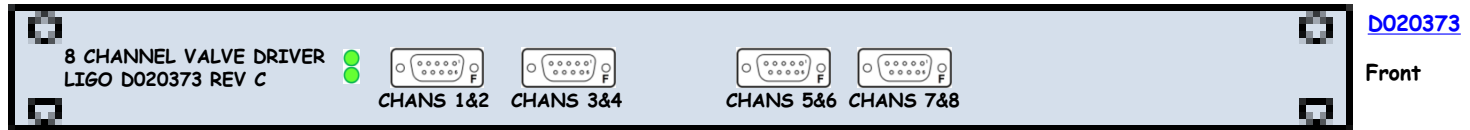



D1001715

Front

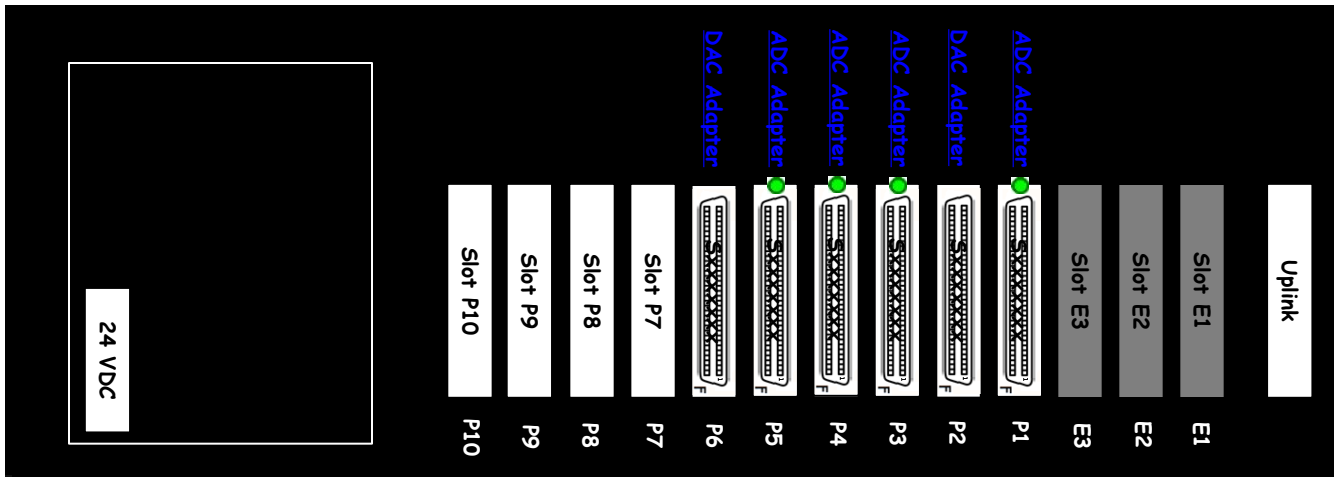

S1001147

Rear

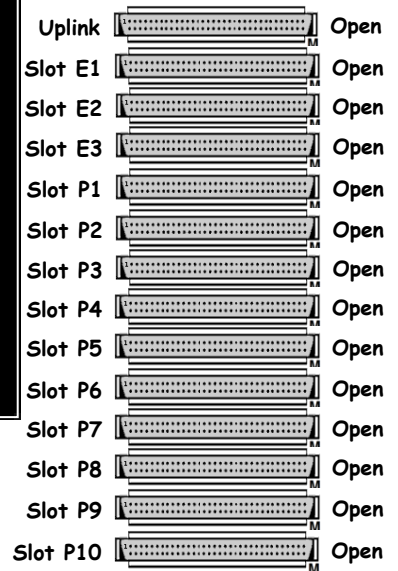

L1-SEI-C5 Details

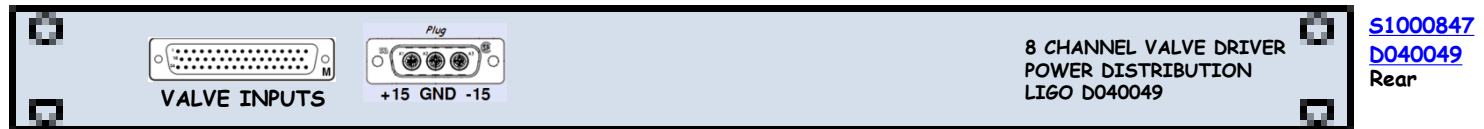
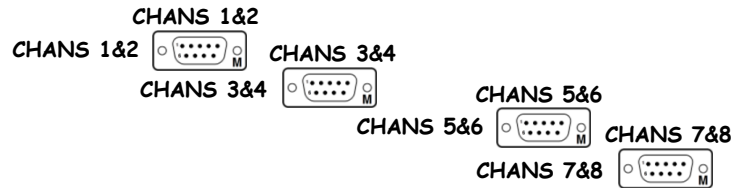
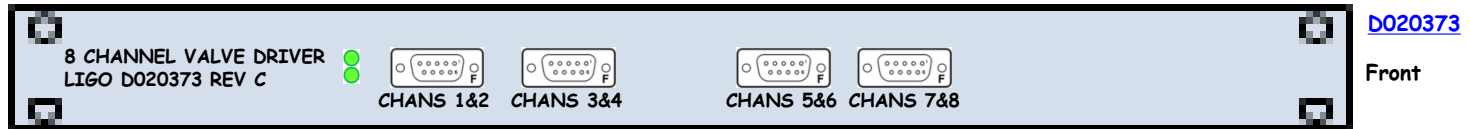

L1-SEI-C6 Details

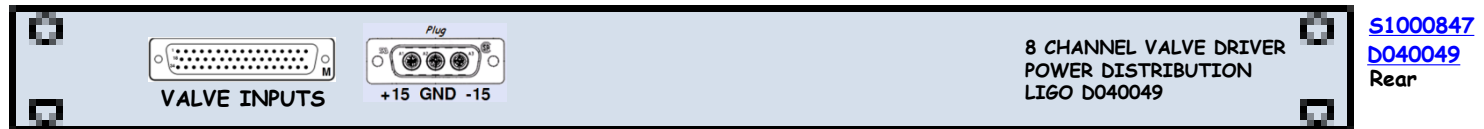
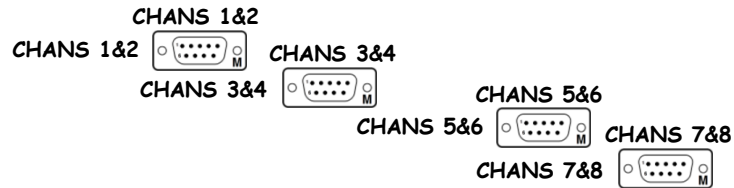
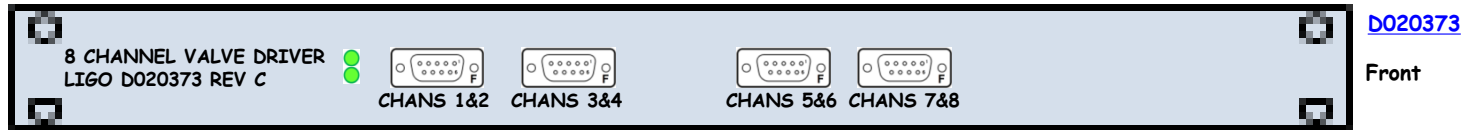



D1001715

Front

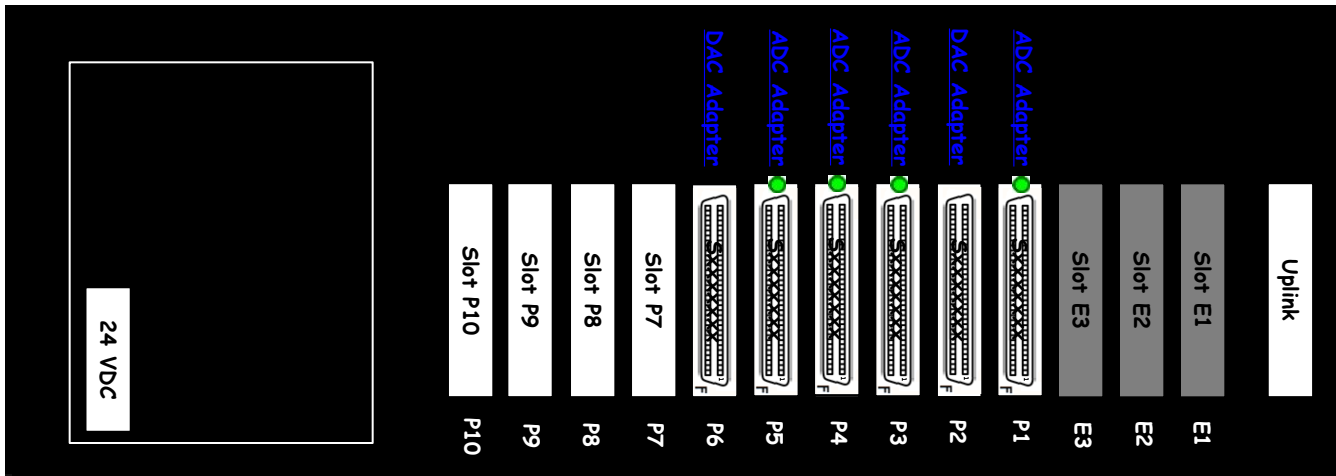

S1100946

Rear

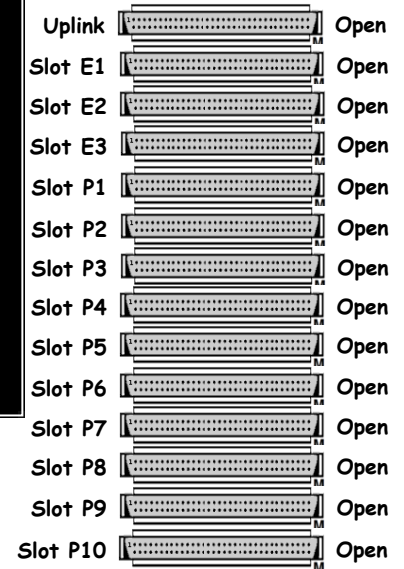

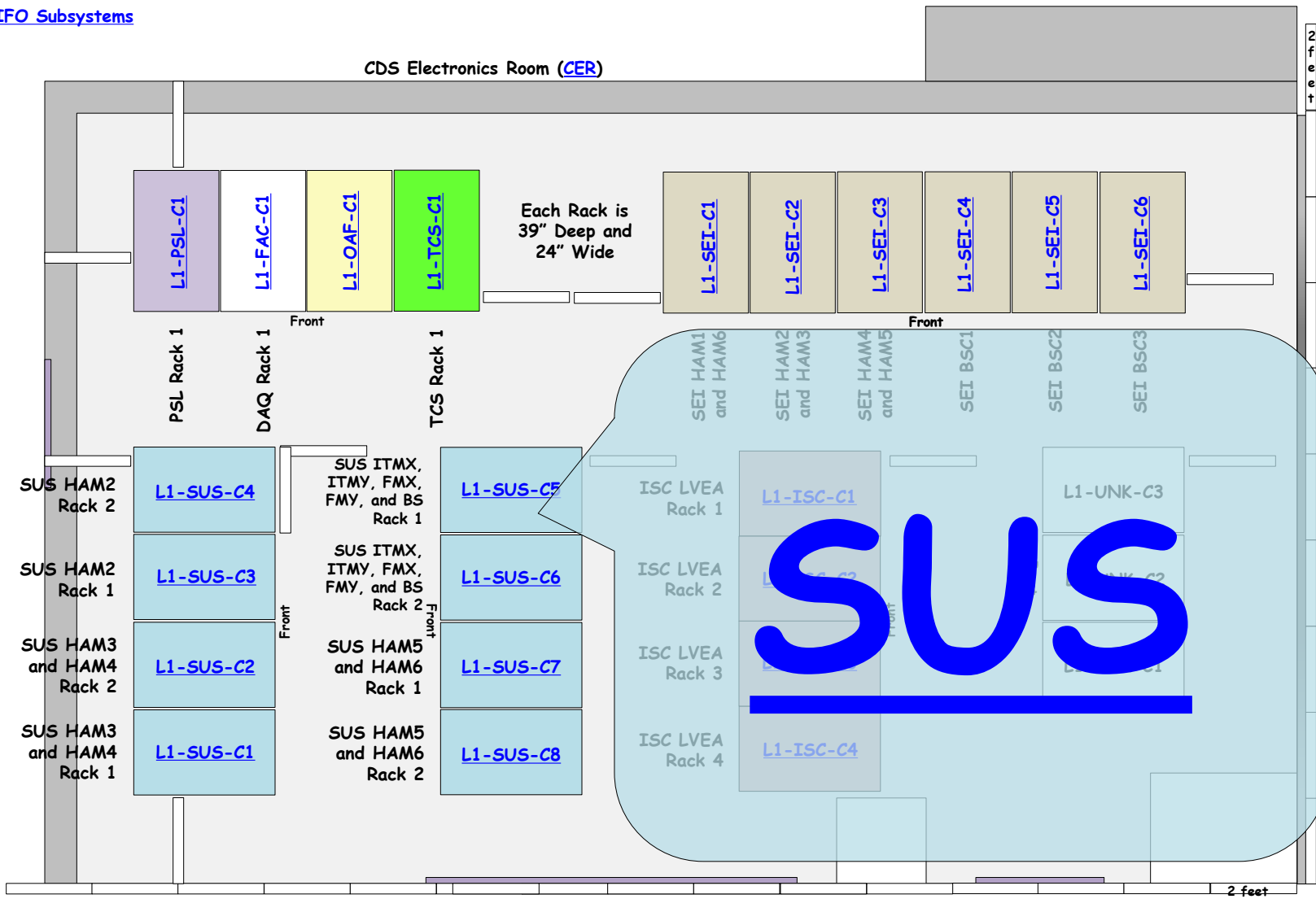

[MON ADC0 Anti-Alias Chassis](#)
[MON ADC1 Anti-Alias Chassis](#)

[MON ADC2 Anti-Alias Chassis](#)
[MON ADC3 Anti-Alias Chassis](#)

[MON ADC4 Anti-Alias Chassis](#)
[MON ADC5 Anti-Alias Chassis](#)

[l1susauxham3-4 MON I/O Extension Chassis](#)

[l1susham3-4 FE I/O Extension Chassis](#)

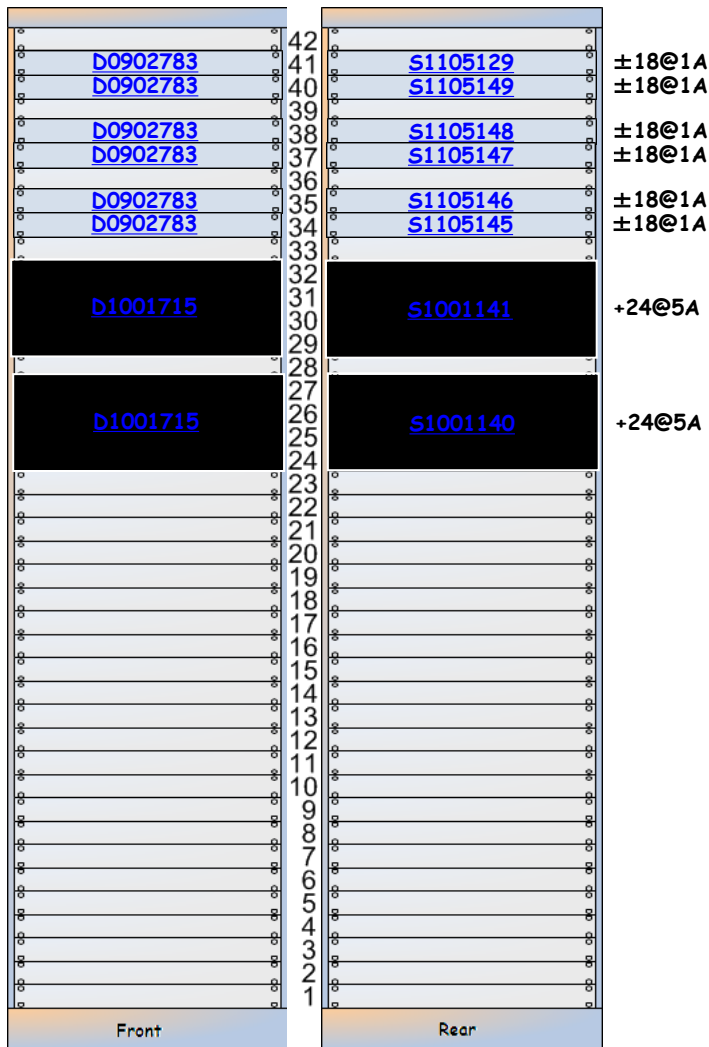
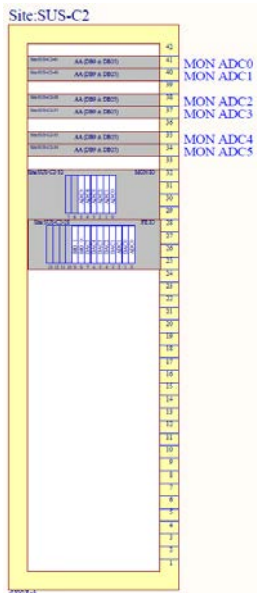

MON ADC0 Anti-Alias Chassis
 MON ADC1 Anti-Alias Chassis
 MON ADC2 Anti-Alias Chassis
 MON ADC3 Anti-Alias Chassis
 MON ADC4 Anti-Alias Chassis
 MON ADC5 Anti-Alias Chassis
 MON ADC6 Anti-Alias Chassis
 MON ADC7 Anti-Alias Chassis

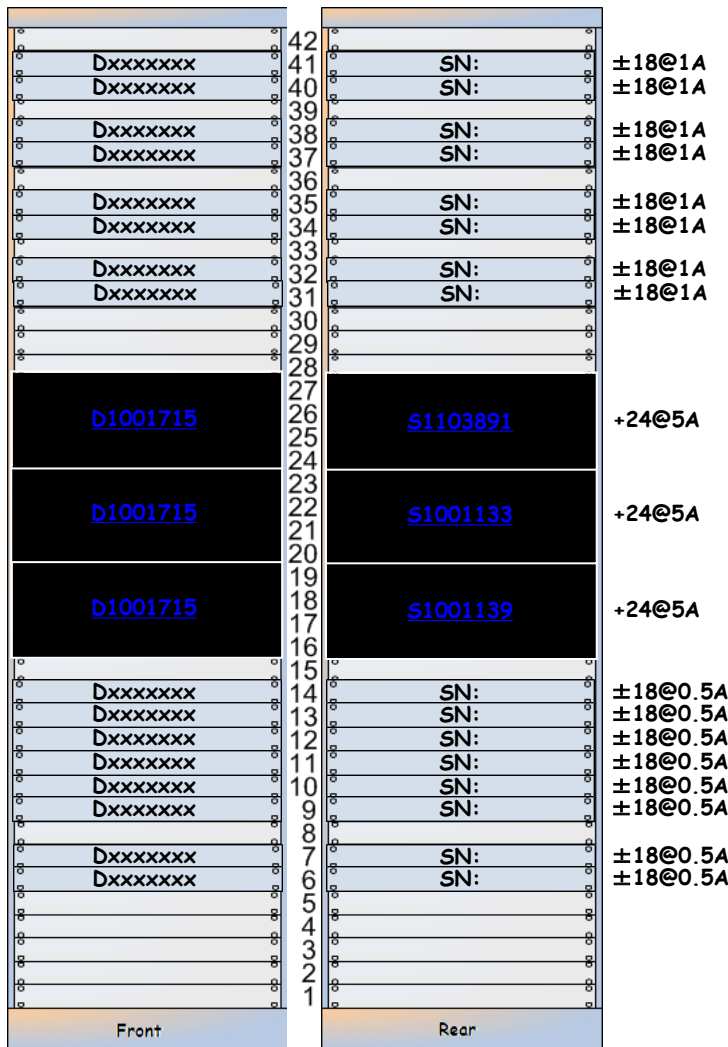

[l1susauxham2 MON I/O Extension Chassis](#)

[l1susham2a FE I/O Extension Chassis](#)

[l1susham2b FE I/O Extension Chassis](#)

BIO 0 Binary Output Chassis
 BIO 0 Binary Input Chassis
 BIO 1 Binary Output Chassis
 BIO 1 Binary Input Chassis
 BIO 2 Binary Output Chassis
 BIO 2 Binary Input Chassis

BIO 0 Binary Output Chassis
 BIO 0 Binary Input Chassis

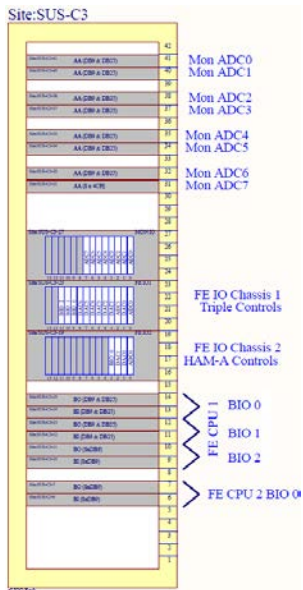

PSY-005

PSO-006

[MC1-MC3 Triple Top Coil Driver Chassis](#)
[MC1-MC3 Triple Top Coil Driver Chassis](#)
[MC1-MC3 Triple Top Coil Driver Chassis](#)

[PRM-PR3 Triple Top Coil Driver Chassis](#)
[PRM-PR3 Triple Top Coil Driver Chassis](#)
[PRM-PR3 Triple Top Coil Driver Chassis](#)

FE1 ADC0 Anti-Alias Chassis
 FE1 ADC1 Anti-Alias Chassis

FE1 DAC0, FE1 DAC1 Anti-Image Chassis
 FE1 DAC2, FE1 DAC3 Anti-Image Chassis

MC1 Mid Triple Acq Driver Chassis
 MC1 Bot Triple Acq Driver Chassis
 MC3 Mid Triple Acq Driver Chassis
 MC3 Bot Triple Acq Driver Chassis

FE1 DAC4, FE1 DAC5 Anti-Image Chassis
 FE1 DAC6 Anti-Image Chassis

PRM Mid Triple Acq Driver Chassis
 PRM Bot Triple Acq Driver Chassis
 PR3 Mid Triple Acq Driver Chassis
 PR3 Bot Triple Acq Driver Chassis

SM2 8-Channel Coil Driver Chassis
 SM2 8-Channel Coil Driver Chassis

FE2 ADC0 Anti-Alias Chassis
 FE2 DAC0 Anti-Image Chassis

PMMT1 8-Channel Coil Driver Chassis
 PMMT2 8-Channel Coil Driver Chassis

| | | | | | |
|--|----------|----|----------|----------|--|
| | | 42 | | | |
| | D1001242 | 41 | S1000253 | ±18@1A | |
| | D1001242 | 40 | S1000261 | ±18@1A | |
| | D1001242 | 39 | S1000262 | ±18@1A | |
| | | 38 | | | |
| | D1001242 | 37 | S1000257 | ±18@1A | |
| | D1001242 | 36 | S1000259 | ±18@1A | |
| | D1001242 | 35 | S1000723 | ±18@1A | |
| | | 34 | | | |
| | Dxxxxxxx | 33 | SN: | ±18@1A | |
| | Dxxxxxxx | 32 | SN: | ±18@1A | |
| | | 31 | | | |
| | Dxxxxxxx | 30 | SN: | ±18@0.5A | |
| | Dxxxxxxx | 29 | SN: | ±18@0.5A | |
| | | 28 | | | |
| | D0900006 | 27 | SN: | ±18@1A | |
| | D0900006 | 26 | SN: | ±18@1A | |
| | D0900006 | 25 | SN: | ±18@1A | |
| | D0900006 | 24 | SN: | ±18@1A | |
| | | 23 | | | |
| | Dxxxxxxx | 22 | SN: | ±18@0.5A | |
| | Dxxxxxxx | 21 | SN: | ±18@0.5A | |
| | | 20 | | | |
| | D0900006 | 19 | SN: | ±18@1A | |
| | D0900006 | 18 | SN: | ±18@1A | |
| | D0900006 | 17 | SN: | ±18@1A | |
| | D0900006 | 16 | SN: | ±18@1A | |
| | | 15 | | | |
| | Dxxxxxxx | 14 | SN: | ±18@1A | |
| | Dxxxxxxx | 13 | SN: | ±18@1A | |
| | | 12 | | | |
| | Dxxxxxxx | 11 | SN: | ±18@1A | |
| | Dxxxxxxx | 10 | SN: | ±18@0.5A | |
| | | 9 | | | |
| | Dxxxxxxx | 8 | SN: | ±18@1A | |
| | Dxxxxxxx | 7 | SN: | ±18@1A | |
| | | 6 | | | |
| | | 5 | | | |
| | | 4 | | | |
| | | 3 | | | |
| | | 2 | | | |
| | | 1 | | | |
| | Front | | Rear | | |

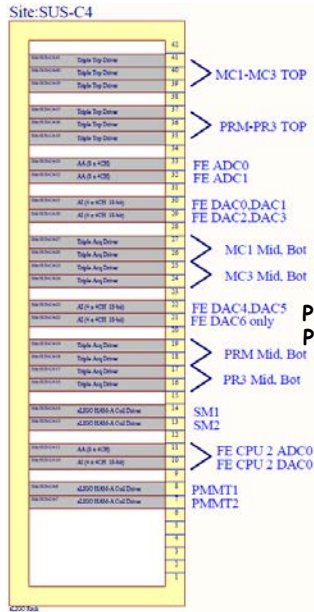
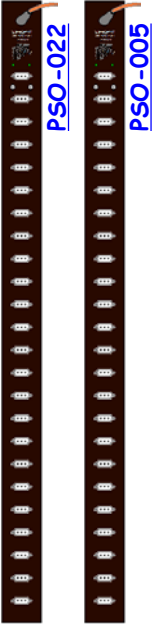

L1-SUS-C5 - S1105375

SUS ITMX, ITMY, and BS Rack 1 (of 2) Layout ([LIGO-D1100022](#)) ([S1105375](#))

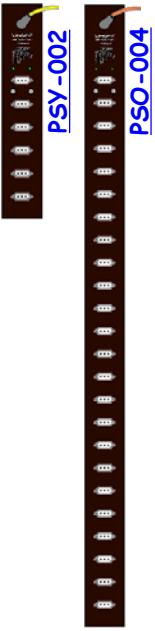
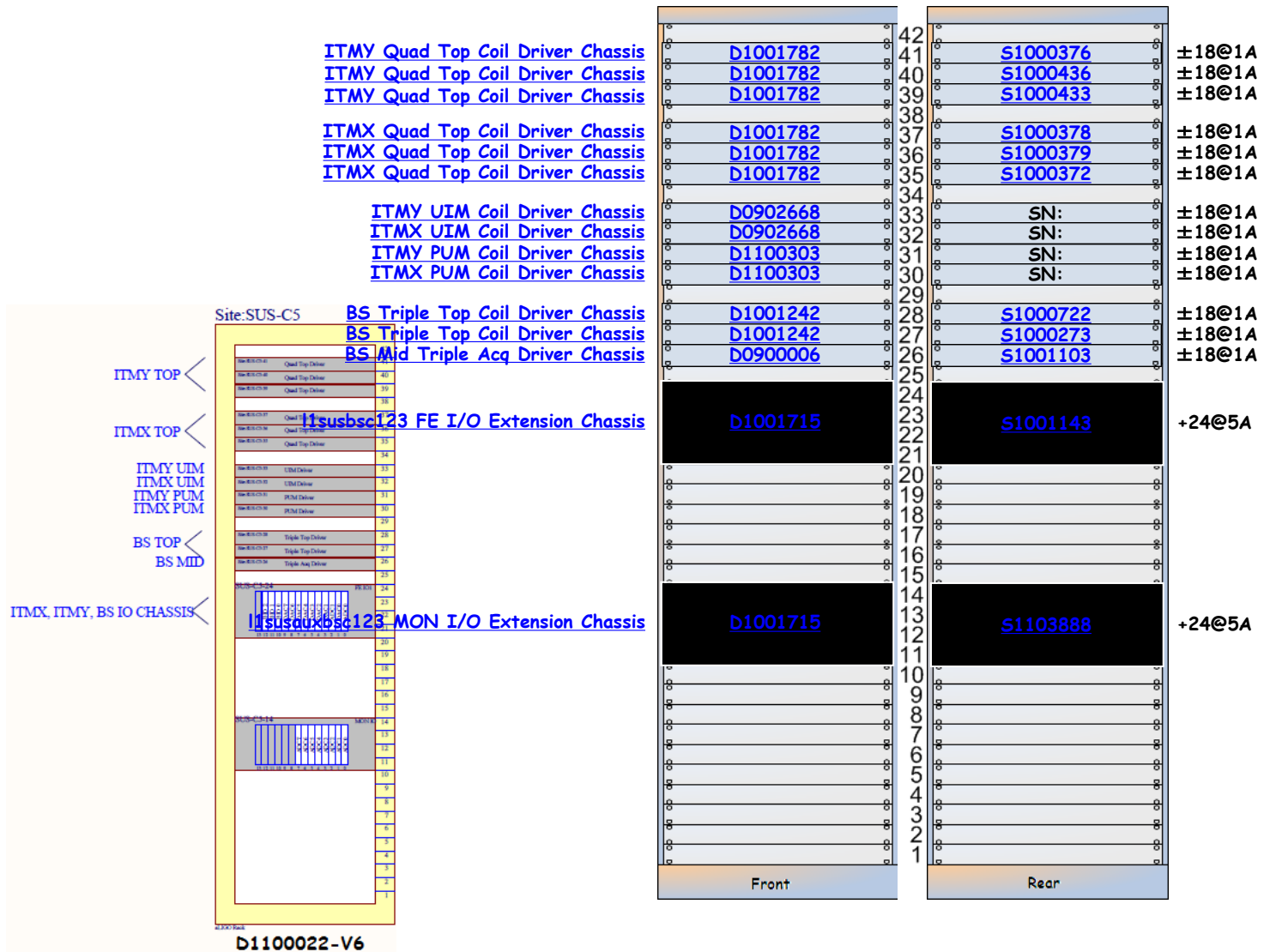

H2-SUS-C5 - S1105375

SUS ITMX, ITMY, BS, FMX, and FMY Rack 1 (of 2) Layout (LIGO-D1001725) (S1105375)

ITMY Quad Top Coil Driver Chassis
 ITMY Quad Top Coil Driver Chassis
 ITMY Quad Top Coil Driver Chassis

ITMX Quad Top Coil Driver Chassis
 ITMX Quad Top Coil Driver Chassis
 ITMX Quad Top Coil Driver Chassis

ITMY UIM Coil Driver Chassis
 ITMX UIM Coil Driver Chassis
 ITMY PUM Coil Driver Chassis
 ITMX PUM Coil Driver Chassis

BS Triple Top Coil Driver Chassis
 BS Triple Top Coil Driver Chassis
 BS Mid Triple Acq Driver Chassis

I1susbsc123 FE I/O Extension Chassis

I1susauxbsc123 MON I/O Extension Chassis

I1susauxbsc123 MON I/O Extension Chassis

FMX Triple Top Coil Driver Chassis
 FMY Triple Top Coil Driver Chassis
 FMX Mid Triple Acq Driver Chassis

FMX Triple Top Coil Driver Chassis
 FMX Triple Top Coil Driver Chassis
 FMX Mid Triple Acq Driver Chassis

Site: SUS-C5

ITMY TOP <

ITMX TOP <

ITMY UIM
 ITMX UIM
 ITMY PUM
 ITMX PUM

BS TOP <

BS MID <

ITMX, ITMY, BS IO CHASSIS <

FMX, FMY IO CHASSIS
 ITM and BS Opt Levers <

FMY TOP <

FMY MID <

FMX TOP <

FMX MID <

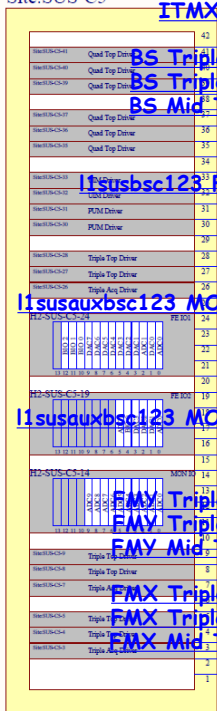

D1001725-v7

| | | | |
|----|----------|----------|--------|
| 42 | | | |
| 41 | D1001782 | S1000376 | ±18@1A |
| 40 | D1001782 | S1000436 | ±18@1A |
| 39 | D1001782 | S1000433 | ±18@1A |
| 38 | | | |
| 37 | D1001782 | S1000378 | ±18@1A |
| 36 | D1001782 | S1000379 | ±18@1A |
| 35 | D1001782 | S1000372 | ±18@1A |
| 34 | | | |
| 33 | D0902668 | SN: | ±18@1A |
| 32 | D0902668 | SN: | ±18@1A |
| 31 | D1100303 | SN: | ±18@1A |
| 30 | D1100303 | SN: | ±18@1A |
| 29 | | | |
| 28 | D1001242 | S1000722 | ±18@1A |
| 27 | D1001242 | S1000273 | ±18@1A |
| 26 | D0900006 | S1001103 | ±18@1A |
| 25 | | | |
| 24 | | | |
| 23 | D1001715 | S1001143 | +24@5A |
| 22 | | | |
| 21 | | | |
| 20 | | | |
| 19 | | | |
| 18 | D1001715 | S1103888 | +24@5A |
| 17 | | | |
| 16 | | | |
| 15 | | | |
| 14 | D1001715 | S1103888 | +24@5A |
| 13 | | | |
| 12 | | | |
| 11 | | | |
| 10 | | | |
| 9 | D1001242 | S1000722 | ±18@1A |
| 8 | D1001242 | S1000273 | ±18@1A |
| 7 | D0900006 | S1001103 | ±18@1A |
| 6 | | | |
| 5 | D1001242 | S1000722 | ±18@1A |
| 4 | D1001242 | S1000273 | ±18@1A |
| 3 | D0900006 | S1001103 | ±18@1A |
| 2 | | | |
| 1 | | | |
| | Front | Rear | |



| | |
|--------|-----|
| +18VDC | 13A |
| -18VDC | 13A |
| +24VDC | 15A |

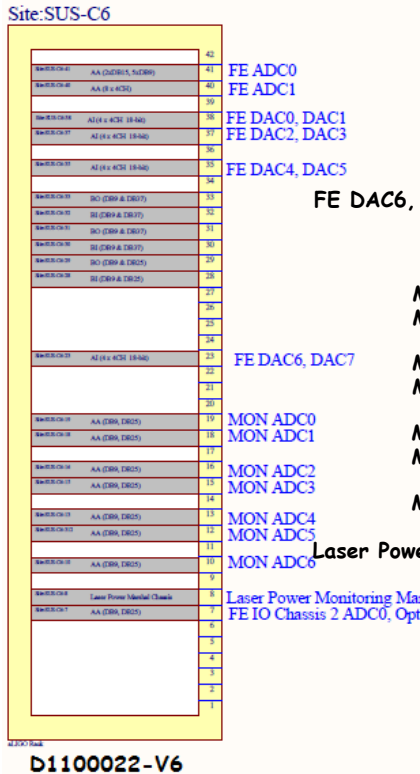

FE ADC0 Anti-Alias Chassis
 FE ADC1 Anti-Alias Chassis
 FE DAC0, FE DAC1 Anti-Image Chassis
 FE DAC2, FE DAC3 Anti-Image Chassis
 FE DAC4, FE DAC5 Anti-Image Chassis
 Binary Output Chassis
 Binary Input Chassis
 Binary Output Chassis
 Binary Input Chassis
 Binary Output Chassis
 Binary Input Chassis

FE DAC6, FE DAC7 Anti-Image Chassis

MON ADC0 Anti-Alias Chassis
 MON ADC1 Anti-Alias Chassis
 MON ADC2 Anti-Alias Chassis
 MON ADC3 Anti-Alias Chassis
 MON ADC4 Anti-Alias Chassis
 MON ADC5 Anti-Alias Chassis
 MON ADC6 Anti-Alias Chassis

Laser Power Monitor Marshaling Chassis
 FE2 ADC0 Anti-Alias Chassis
 Laser Power Monitoring Marshaling Chassis
 FE IO Chassis 2 ADC0, Opt Lever Signals

| | | | |
|----|----------|-----|----------|
| 42 | | | |
| 41 | Dxxxxxxx | SN: | ±18@1A |
| 40 | Dxxxxxxx | SN: | ±18@1A |
| 39 | | | |
| 38 | Dxxxxxxx | SN: | ±18@1A |
| 37 | Dxxxxxxx | SN: | ±18@1A |
| 36 | | | |
| 35 | Dxxxxxxx | SN: | ±18@1A |
| 34 | | | |
| 33 | Dxxxxxxx | SN: | ±18@0.5A |
| 32 | Dxxxxxxx | SN: | ±18@0.5A |
| 31 | Dxxxxxxx | SN: | ±18@0.5A |
| 30 | Dxxxxxxx | SN: | ±18@0.5A |
| 29 | Dxxxxxxx | SN: | ±18@0.5A |
| 28 | Dxxxxxxx | SN: | ±18@0.5A |
| 27 | | | |
| 26 | | | |
| 25 | | | |
| 24 | | | |
| 23 | Dxxxxxxx | SN: | ±18@1A |
| 22 | | | |
| 21 | | | |
| 20 | Dxxxxxxx | SN: | ±18@1A |
| 19 | Dxxxxxxx | SN: | ±18@1A |
| 18 | | | |
| 17 | Dxxxxxxx | SN: | ±18@1A |
| 16 | Dxxxxxxx | SN: | ±18@1A |
| 15 | | | |
| 14 | Dxxxxxxx | SN: | ±18@1A |
| 13 | Dxxxxxxx | SN: | ±18@1A |
| 12 | | | |
| 11 | | | |
| 10 | Dxxxxxxx | SN: | ±18@1A |
| 9 | | | |
| 8 | Dxxxxxxx | SN: | ±18@1A |
| 7 | Dxxxxxxx | SN: | ±18@1A |
| 6 | | | |
| 5 | | | |
| 4 | | | |
| 3 | | | |
| 2 | | | |
| 1 | | | |

Front Rear

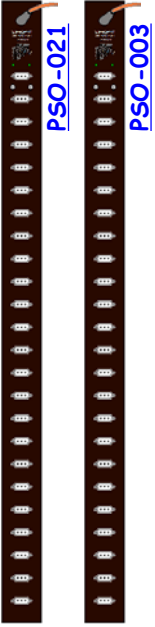

Site:SUS-C6

| | |
|----|-----------------------------|
| 42 | |
| 41 | AA (2xDB1, 1xDB9) |
| 40 | AA (8 x 4CR) |
| 39 | |
| 38 | AI (4 x 4CH 18-46) |
| 37 | AI (4 x 4CH 18-46) |
| 36 | |
| 35 | AI (4 x 4CH 18-46) |
| 34 | |
| 33 | BO (DB9 & DB17) |
| 32 | BI (DB9 & DB17) |
| 31 | BO (DB9 & DB17) |
| 30 | BI (DB9 & DB17) |
| 29 | BO (DB9 & DB17) |
| 28 | BI (DB9 & DB17) |
| 27 | BO (4xDB6, 2xDB17) |
| 26 | BI (4xDB6, 2xDB17) |
| 25 | |
| 24 | AA (8 x 4CR) |
| 23 | AI (2xDB1, 1xDB9 18-46) |
| 22 | |
| 21 | AI (4 x 4CH 18-46) |
| 20 | AI (4 x 4CH 18-46) |
| 19 | |
| 18 | AA (DB9, DB17) |
| 17 | AA (DB9, DB17) |
| 16 | |
| 15 | AA (DB9, DB17) |
| 14 | AA (DB9, DB17) |
| 13 | |
| 12 | AA (DB9, DB17) |
| 11 | AA (DB9, DB17) |
| 10 | |
| 9 | AA (DB9, DB17) |
| 8 | AA (DB9, DB17) |
| 7 | |
| 6 | AA (DB9, DB17) |
| 5 | AA (DB9, DB17) |
| 4 | AA (DB9, DB17) |
| 3 | AA (DB9, DB17) |
| 2 | Laser Power Monitor Chassis |
| 1 | AA (8 x 4CR) |

FE ADC0
FE ADC1

FE DAC0, DAC1
FE DAC2, DAC3

FE DAC4, DAC5

FM FE ADC0 Anti-Alias Chassis
FE DAC6, FE DAC7 Anti-Image Chassis

FE DAC8, FE DAC9 Anti-Image Chassis
FE DAC10 Anti-Image Chassis

FM FE ADC0
FE DAC6, DAC7

FE DAC8, DAC9
FE DAC10

MON ADC0
MON ADC1

MON ADC2
MON ADC3

MON ADC4
MON ADC5

MON ADC6
MON ADC7

MON ADC8
MON ADC9

Laser Power Monitor Marshaling Chassis
FM FE ADC1 Anti-Alias Chassis

FE ADC0 Anti-Alias Chassis
FE ADC1 Anti-Alias Chassis

FE DAC0, FE DAC1 Anti-Image Chassis
FE DAC2, FE DAC3 Anti-Image Chassis

FE DAC4, FE DAC5 Anti-Image Chassis

Binary Output Chassis
Binary Input Chassis
Binary Output Chassis
Binary Input Chassis
Binary Output Chassis
Binary Input Chassis
Binary Output Chassis
Binary Input Chassis

MON ADC0 Anti-Alias Chassis
MON ADC1 Anti-Alias Chassis

MON ADC2 Anti-Alias Chassis
MON ADC3 Anti-Alias Chassis

MON ADC4 Anti-Alias Chassis
MON ADC5 Anti-Alias Chassis

MON ADC6 Anti-Alias Chassis
MON ADC7 Anti-Alias Chassis

MON ADC8 Anti-Alias Chassis
MON ADC9 Anti-Alias Chassis

| | | | |
|----|----------|-----|----------|
| 42 | | | |
| 41 | Dxxxxxxx | SN: | ±18@1A |
| 40 | Dxxxxxxx | SN: | ±18@1A |
| 39 | | | |
| 38 | Dxxxxxxx | SN: | ±18@1A |
| 37 | Dxxxxxxx | SN: | ±18@1A |
| 36 | | | |
| 35 | Dxxxxxxx | SN: | ±18@1A |
| 34 | | | |
| 33 | Dxxxxxxx | SN: | ±18@0.5A |
| 32 | Dxxxxxxx | SN: | ±18@0.5A |
| 31 | Dxxxxxxx | SN: | ±18@0.5A |
| 30 | Dxxxxxxx | SN: | ±18@0.5A |
| 29 | Dxxxxxxx | SN: | ±18@0.5A |
| 28 | Dxxxxxxx | SN: | ±18@0.5A |
| 27 | Dxxxxxxx | SN: | ±18@0.5A |
| 26 | Dxxxxxxx | SN: | ±18@0.5A |
| 25 | | | |
| 24 | Dxxxxxxx | SN: | ±18@1A |
| 23 | Dxxxxxxx | SN: | ±18@1A |
| 22 | | | |
| 21 | Dxxxxxxx | SN: | ±18@1A |
| 20 | Dxxxxxxx | SN: | ±18@1A |
| 19 | | | |
| 18 | Dxxxxxxx | SN: | ±18@1A |
| 17 | Dxxxxxxx | SN: | ±18@1A |
| 16 | | | |
| 15 | Dxxxxxxx | SN: | ±18@1A |
| 14 | Dxxxxxxx | SN: | ±18@1A |
| 13 | | | |
| 12 | Dxxxxxxx | SN: | ±18@1A |
| 11 | Dxxxxxxx | SN: | ±18@1A |
| 10 | | | |
| 9 | Dxxxxxxx | SN: | ±18@1A |
| 8 | Dxxxxxxx | SN: | ±18@1A |
| 7 | | | |
| 6 | Dxxxxxxx | SN: | ±18@1A |
| 5 | Dxxxxxxx | SN: | ±18@1A |
| 4 | Dxxxxxxx | SN: | ±18@1A |
| 3 | Dxxxxxxx | SN: | ±18@1A |
| 2 | | | |
| 1 | | | |

Front

Rear



SR3-SRM Triple Top Coil Driver Chassis
 SR3-SRM Triple Top Coil Driver Chassis
 SR3-SRM Triple Top Coil Driver Chassis

OMC Triple Top Coil Driver Chassis
 OMC Triple Top Coil Driver Chassis

FE ADC0 Anti-Alias Chassis
 FE ADC1 Anti-Alias Chassis

[FE DAC0, FE DAC1 Anti-Image Chassis](#)
[FE DAC2, FE DAC3 Anti-Image Chassis](#)

SR3 Mid Triple Acq Driver Chassis
 SR3 Bot Triple Acq Driver Chassis
 SRM Mid Triple Acq Driver Chassis

[FE DAC4 Anti-Image Chassis](#)

SRM Bot Triple Acq Driver Chassis

Binary Output Chassis
 Binary Input Chassis
 Binary Output Chassis
 Binary Input Chassis

| | | | | |
|----------|----|------|--|----------|
| | 42 | | | |
| D1001242 | 41 | SN: | | ±18@1A |
| D1001242 | 40 | SN: | | ±18@1A |
| D1001242 | 39 | SN: | | ±18@1A |
| | 38 | | | |
| D1001242 | 37 | SN: | | ±18@1A |
| D1001242 | 36 | SN: | | ±18@1A |
| | 35 | | | |
| Dxxxxxxx | 34 | SN: | | ±18@1A |
| Dxxxxxxx | 33 | SN: | | ±18@1A |
| | 32 | | | |
| D1003224 | 31 | SN: | | ±18@0.5A |
| D1003224 | 30 | SN: | | ±18@0.5A |
| | 29 | | | |
| D0900006 | 28 | SN: | | ±18@1A |
| D0900006 | 27 | SN: | | ±18@1A |
| D0900006 | 26 | SN: | | ±18@1A |
| | 25 | | | |
| D1003224 | 24 | SN: | | ±18@0.5A |
| | 23 | | | |
| D0900006 | 22 | SN: | | ±18@1A |
| | 21 | | | |
| Dxxxxxxx | 20 | SN: | | ±18@0.5A |
| Dxxxxxxx | 19 | SN: | | ±18@0.5A |
| Dxxxxxxx | 18 | SN: | | ±18@0.5A |
| Dxxxxxxx | 17 | SN: | | ±18@0.5A |
| | 16 | | | |
| | 15 | | | |
| | 14 | | | |
| | 13 | | | |
| | 12 | | | |
| | 11 | | | |
| | 10 | | | |
| | 9 | | | |
| | 8 | | | |
| | 7 | | | |
| | 6 | | | |
| | 5 | | | |
| | 4 | | | |
| | 3 | | | |
| | 2 | | | |
| | 1 | | | |
| Front | | Rear | | |

| | |
|--------|-------|
| +18VDC | 14.5A |
| -18VDC | 14.5A |



MON ADC0 Anti-Alias Chassis
 MON ADC1 Anti-Alias Chassis
 MON ADC2 Anti-Alias Chassis
 MON ADC3 Anti-Alias Chassis
 MON ADC4 Anti-Alias Chassis

[I1susauxham5-6 MON I/O Extension Chassis](#)

[I1susham5-6 FE I/O Extension Chassis](#)

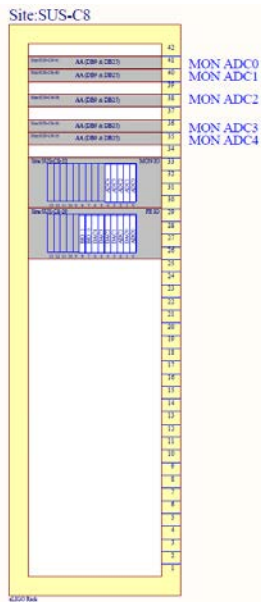
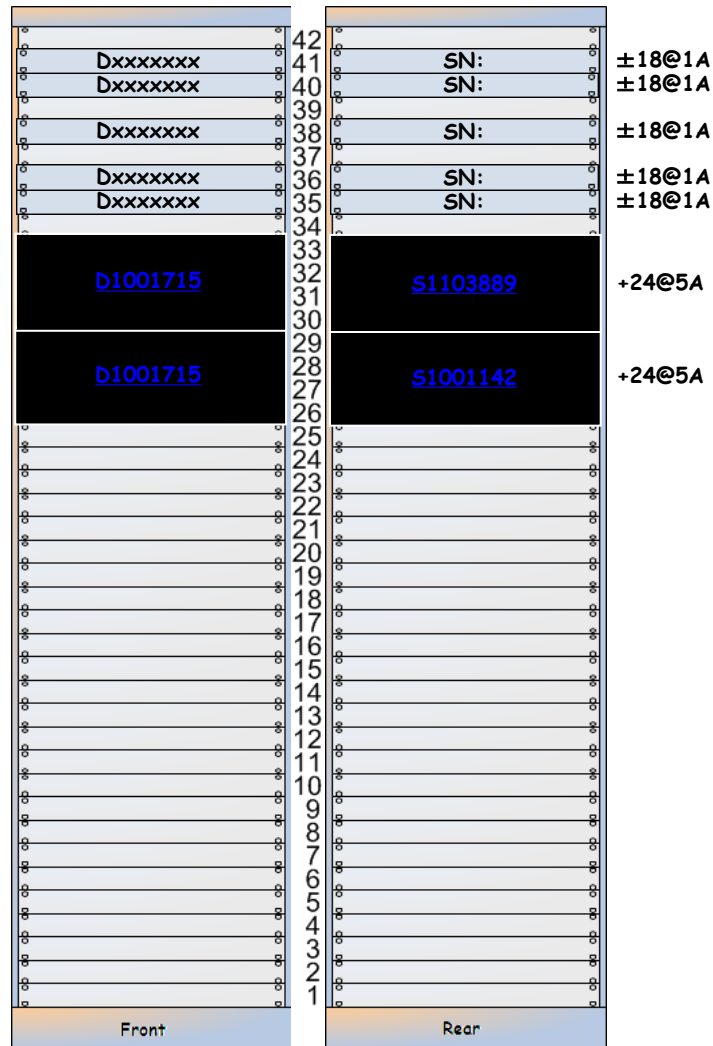

L1-SUS-C1 Details

D1001242 - S1000260



<< L1-SUS-C1

MC2-PR2 Triple Top Coil Driver Chassis D1001242 S1000260 ±18@0.5A

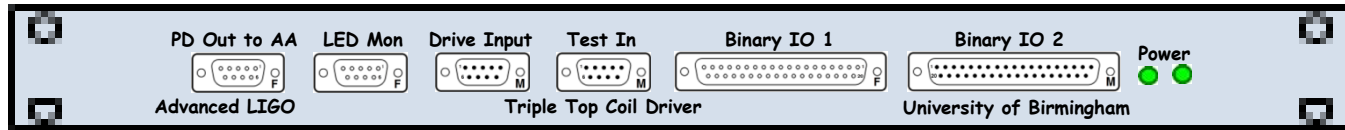

[D0902747](#)
[D070480](#)
Front

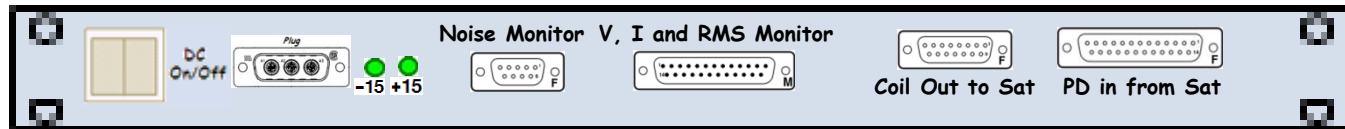
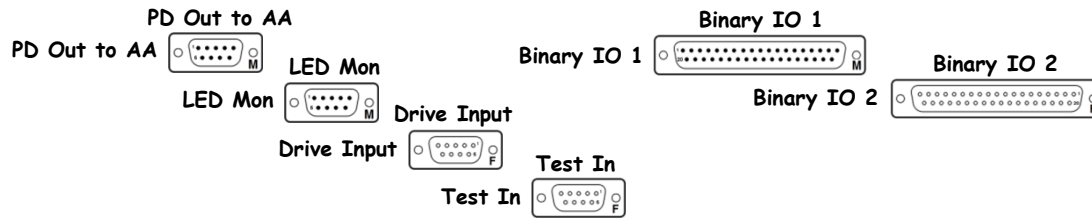

[S1000260](#)
Rear

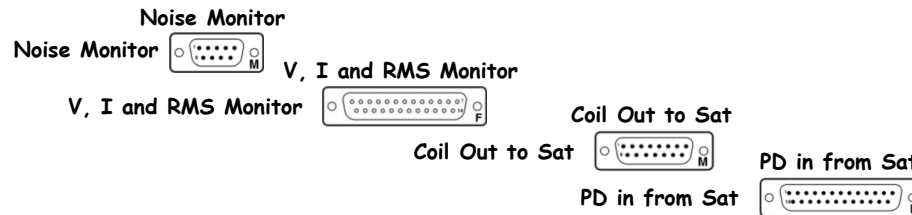

D1001242 - S1000264



<< L1-SUS-C1

MC2-PR2 Triple Top Coil Driver Chassis D1001242 S1000264 ±18@0.5A

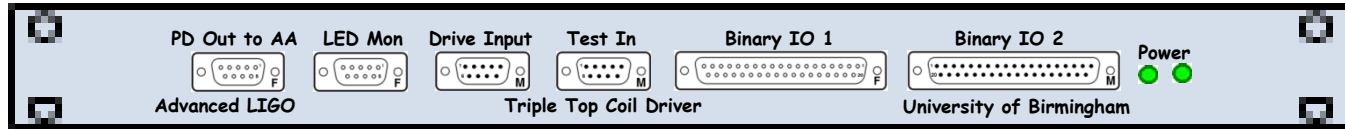

[D0902747](#)
[D070480](#)
Front

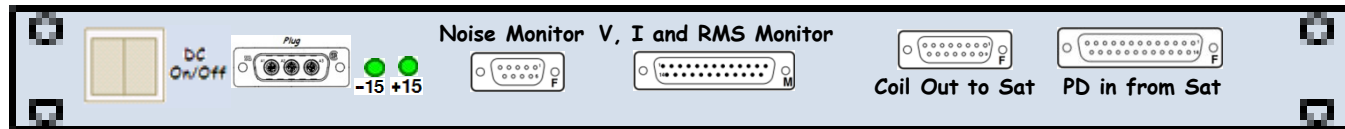
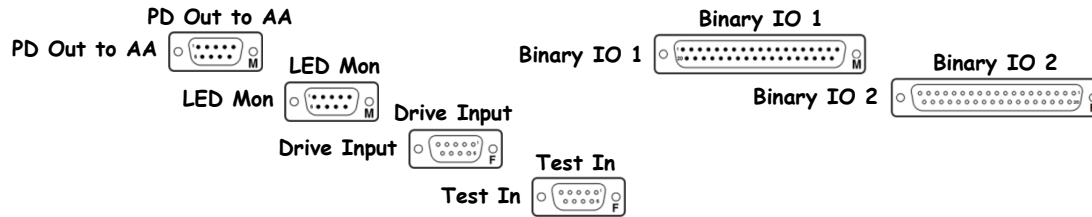

[S1000264](#)
Rear

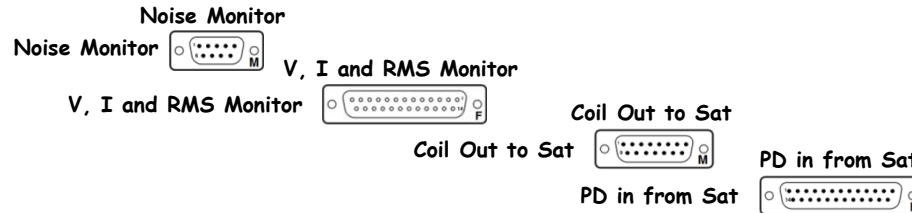

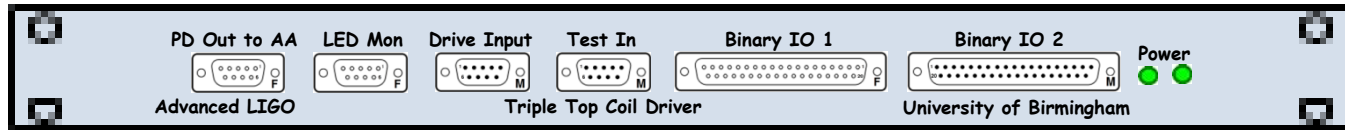

[D0902747](#)
[D070480](#)
Front

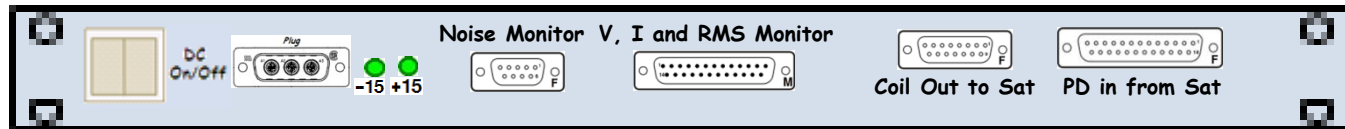
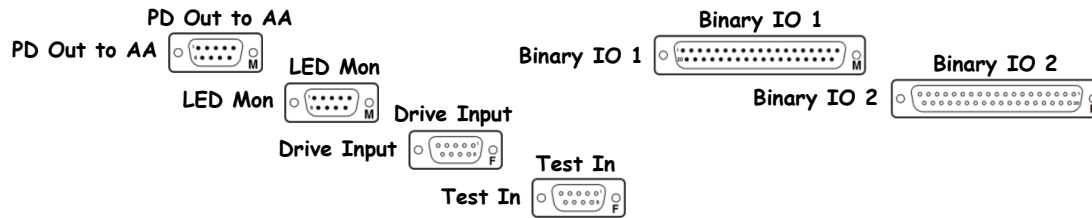

[S1000721](#)
Rear

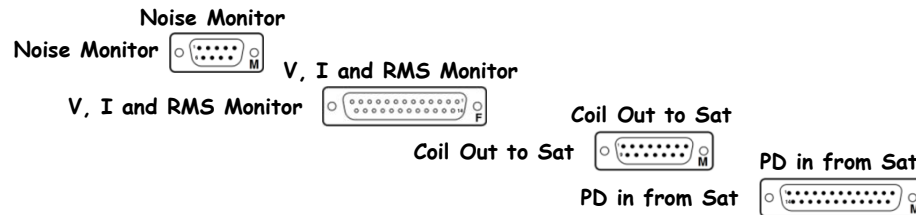

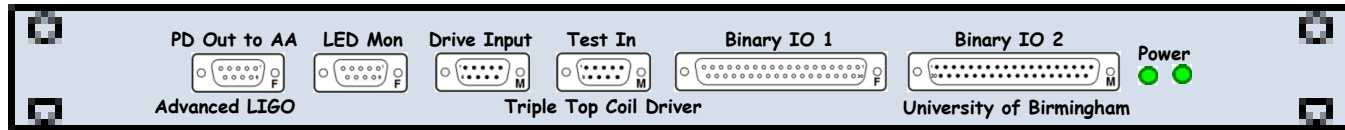

[D0902747](#)
[D070480](#)
Front

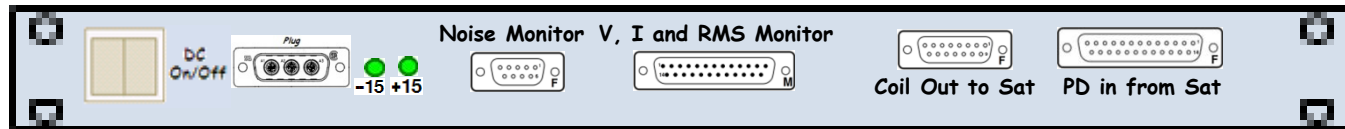
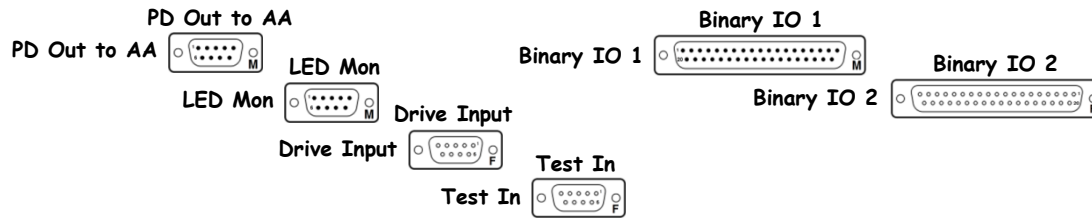

[S1000722](#)
Rear

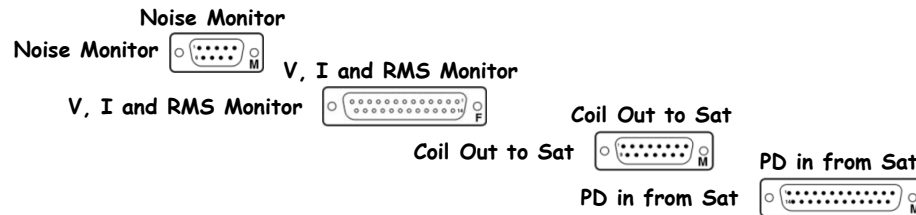

D1001242 - S1000273



<< L1-SUS-C1

SR2 Triple Top Coil Driver Chassis D1001242 S1000273 ±18@0.5A

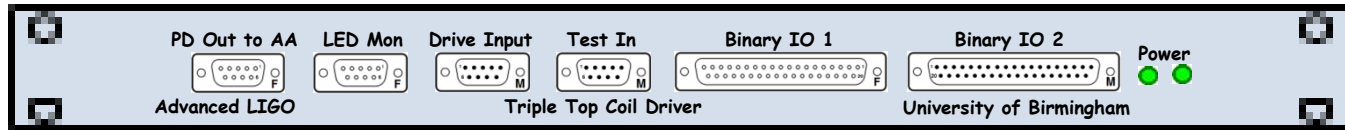

[D0902747](#)
[D070480](#)
Front

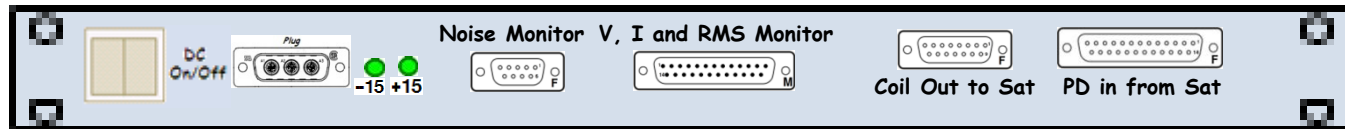
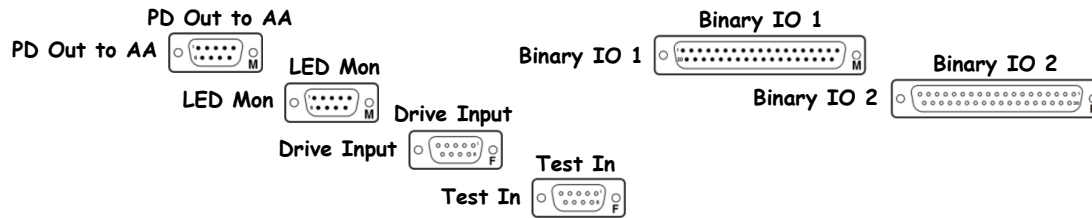

[S1000273](#)
Rear

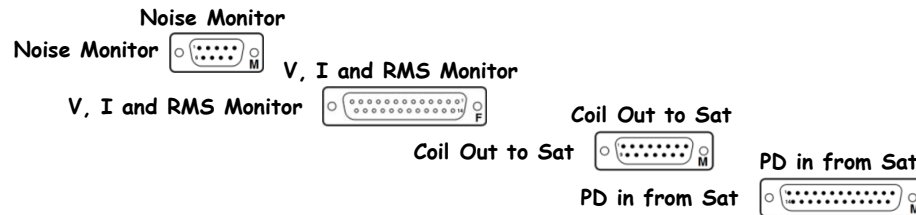

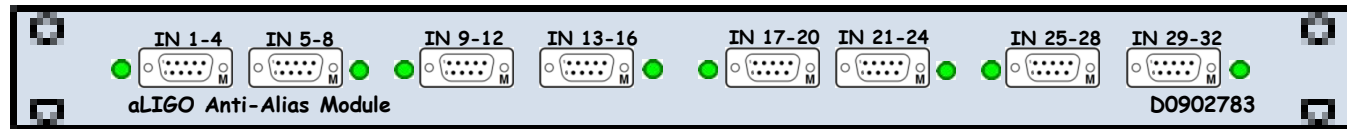
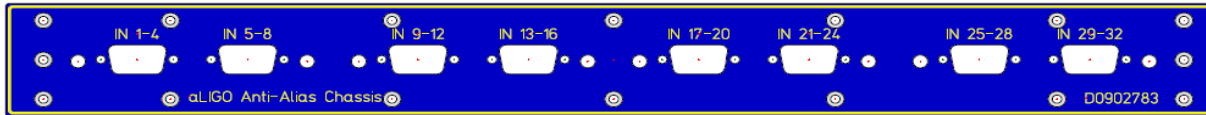

D0902783

Front

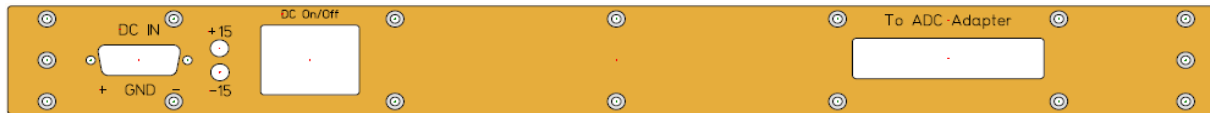
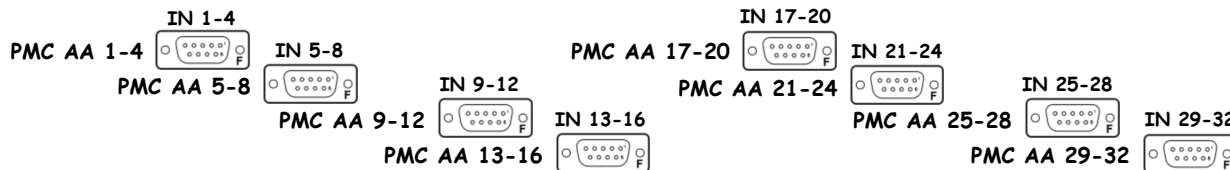

S1001157

Rear



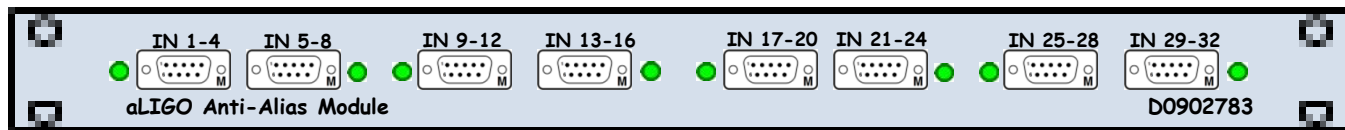
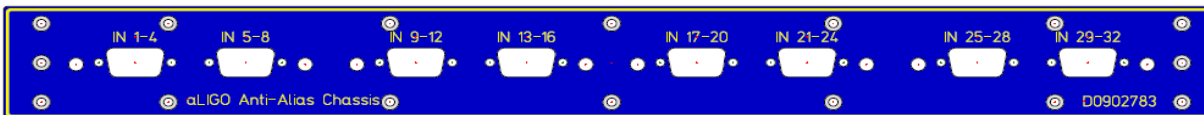

D0902783

Front

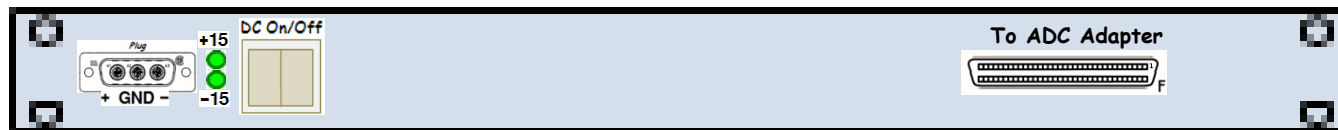
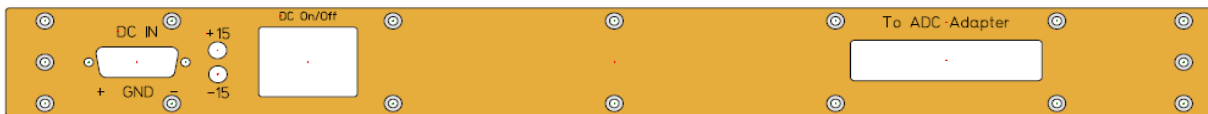
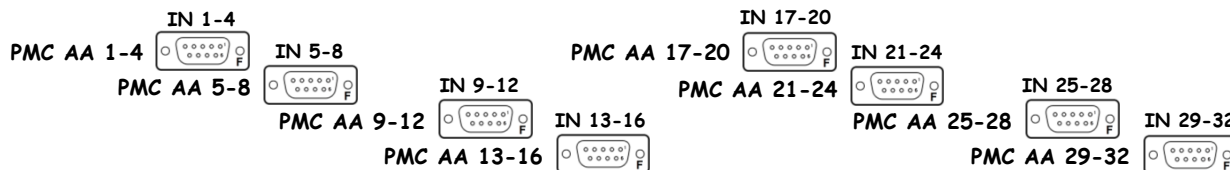

S1100327

Rear



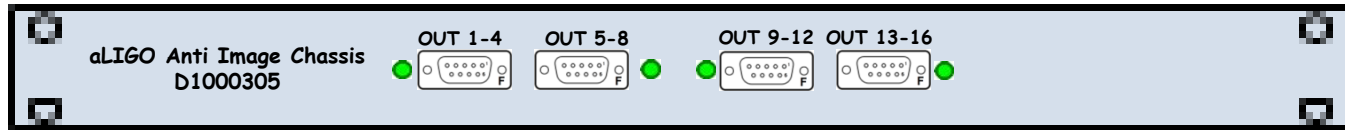
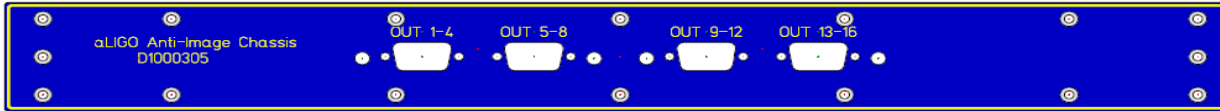

D1000305

Front

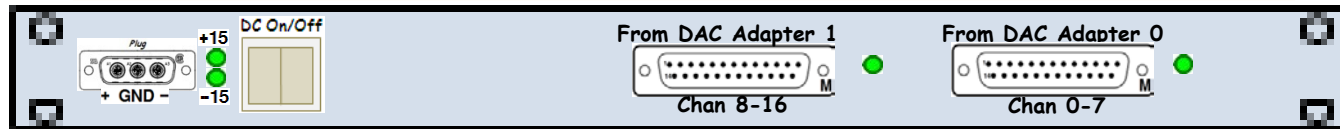
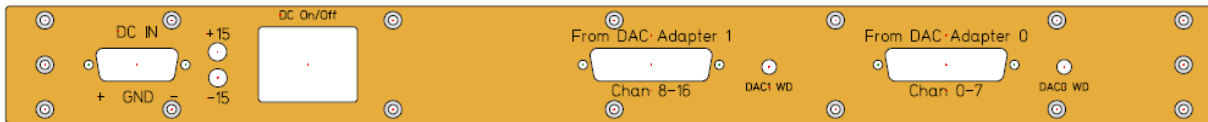

S1001197

Rear

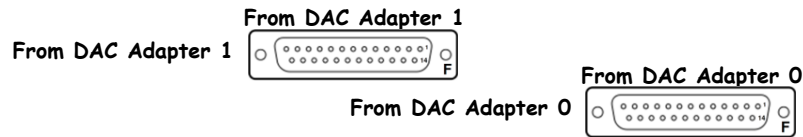

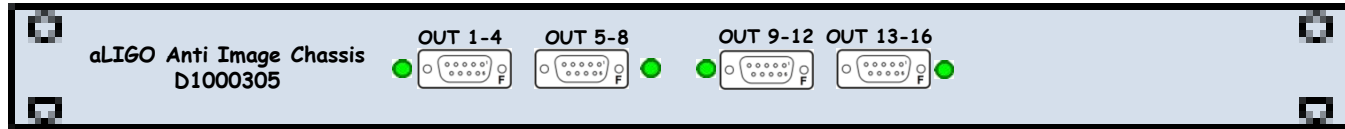
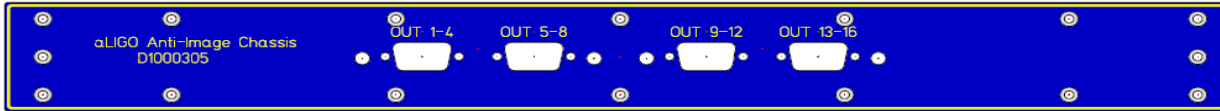

D1000305

Front

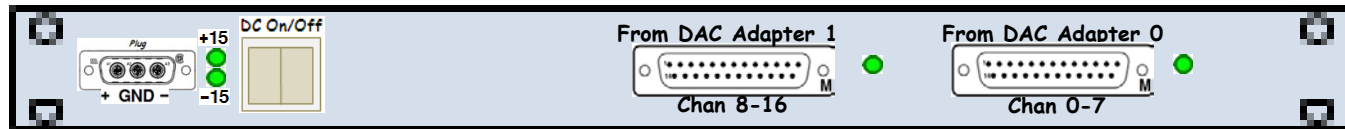
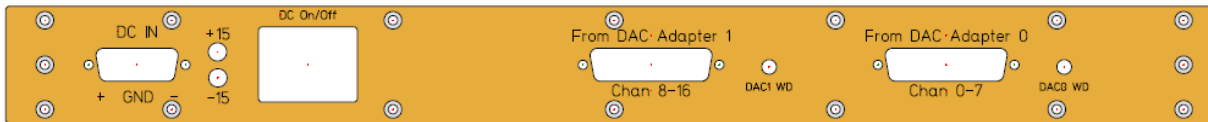

S1001198

Rear

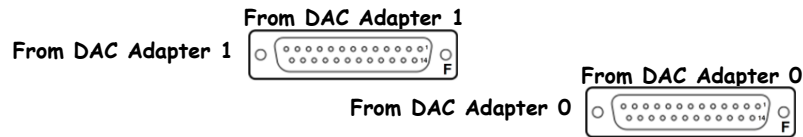

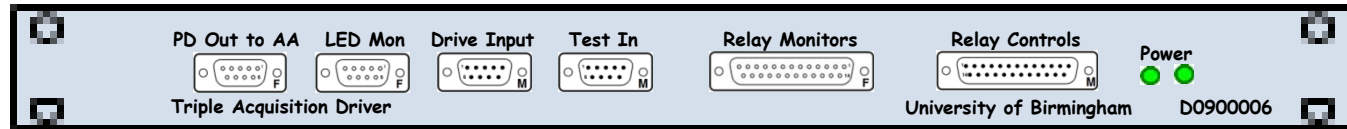

[D0901047](#)
[D070480](#)
Front

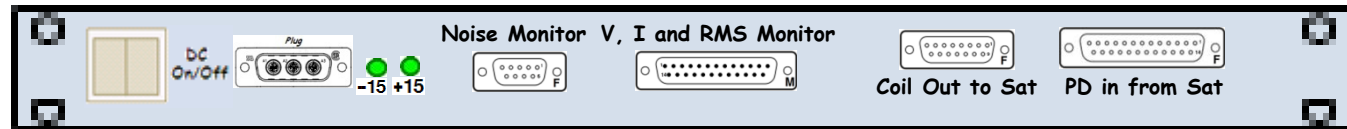
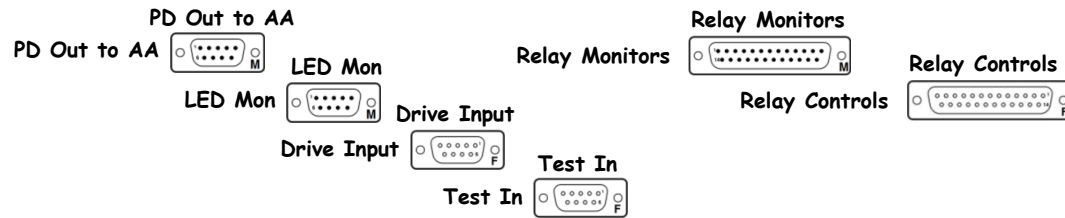

[S1000347](#)
Rear

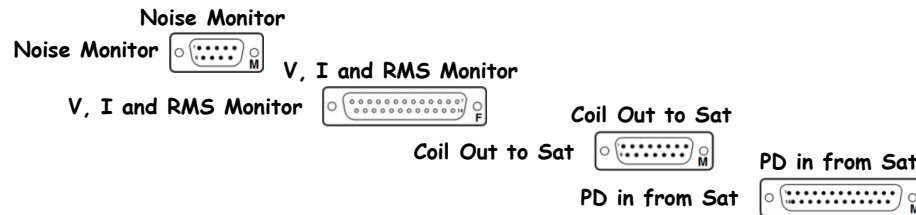

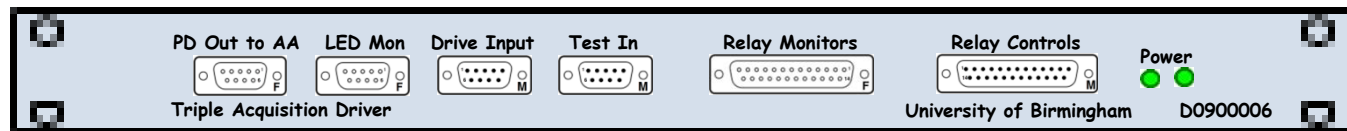

[D0901047](#)
[D070480](#)
Front

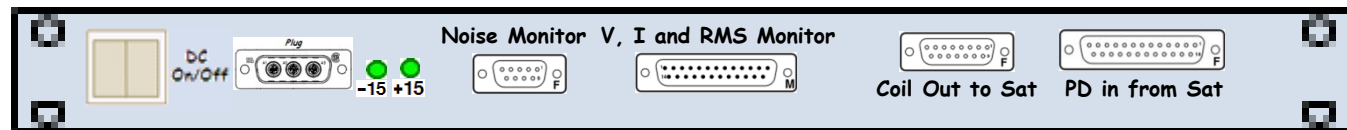
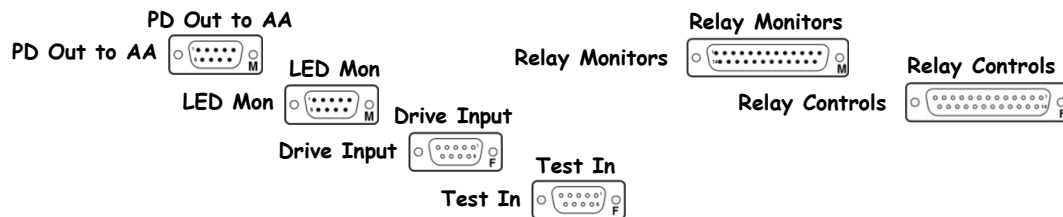

[S1000348](#)
Rear

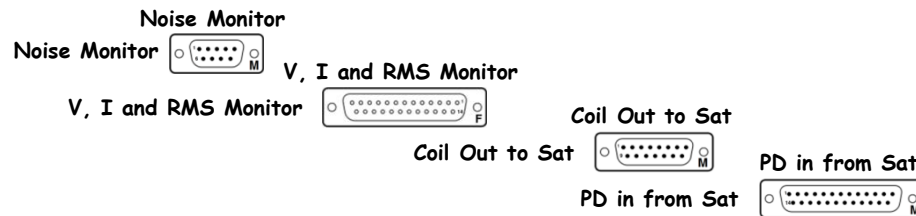

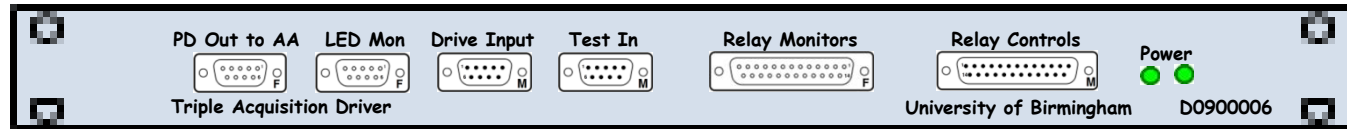

[D0901047](#)
[D070480](#)
Front

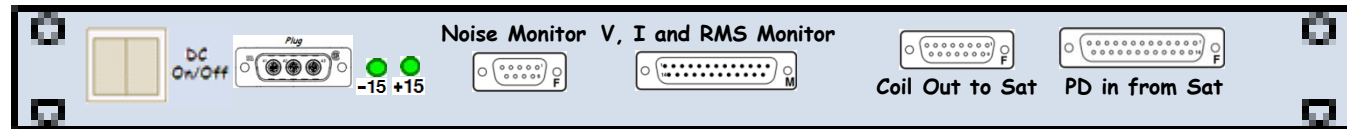
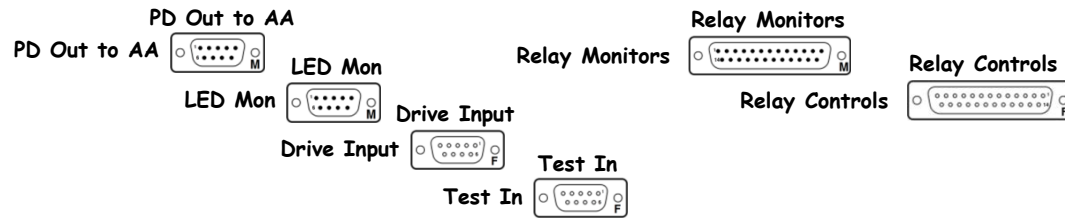

[S1000349](#)
Rear

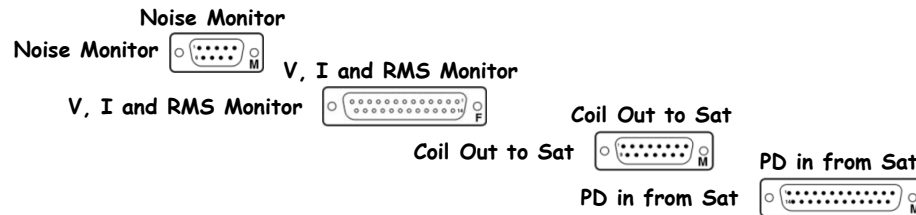

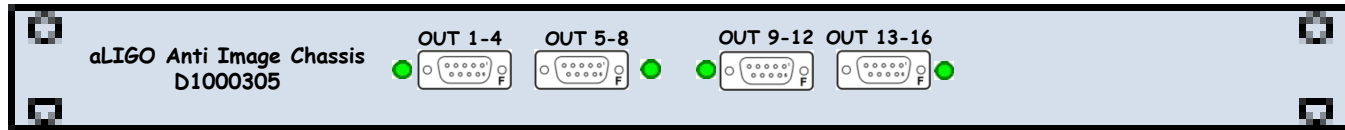
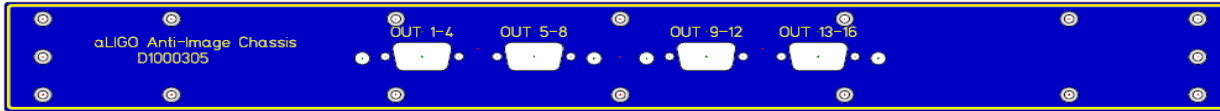

D1000305

Front

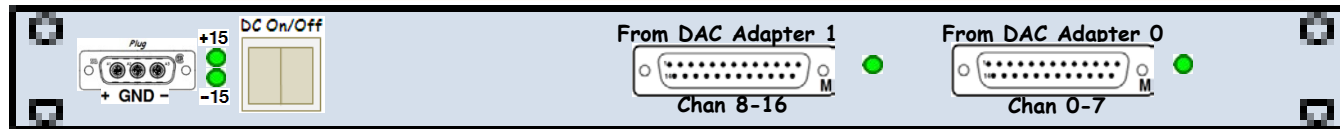
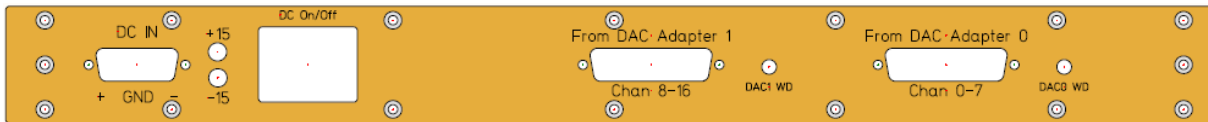

S1101815

Rear

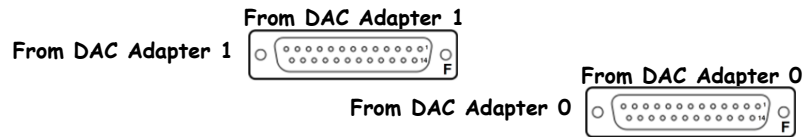

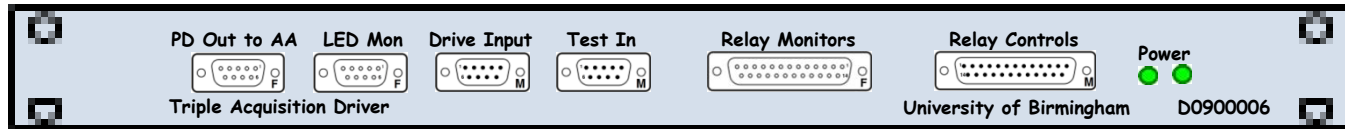

[D0901047](#)
[D070480](#)
Front

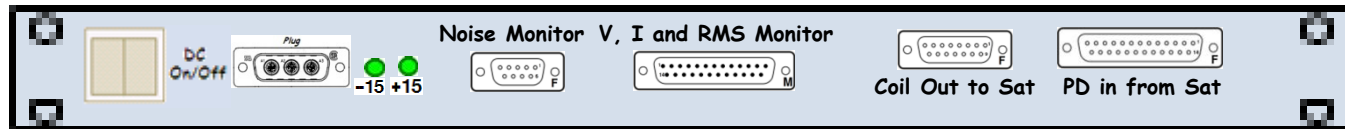
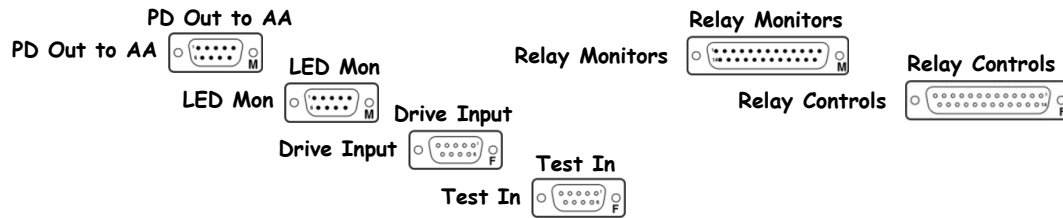

[S1001186](#)
Rear

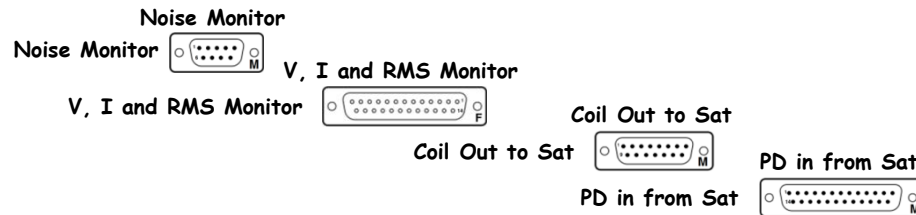

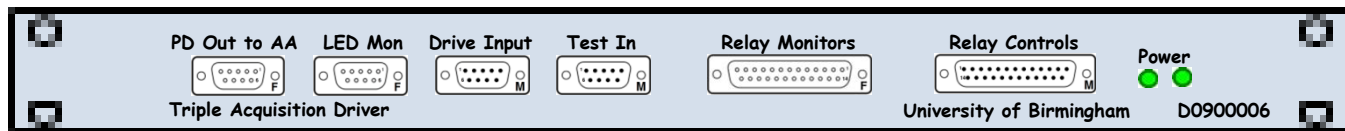

[D0901047](#)
[D070480](#)
 Front

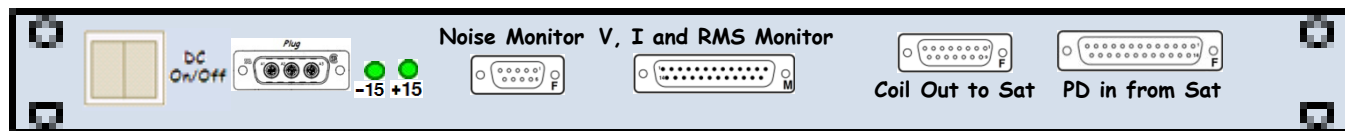
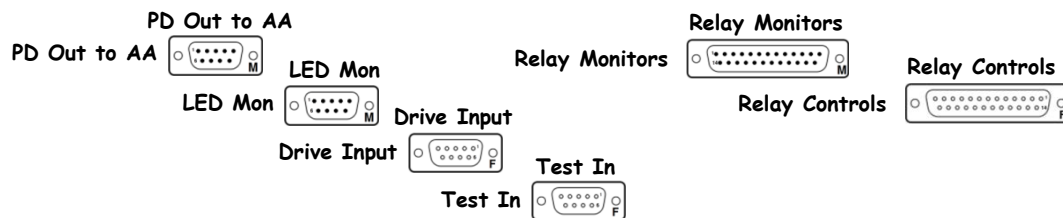

[S1001187](#)
 Rear

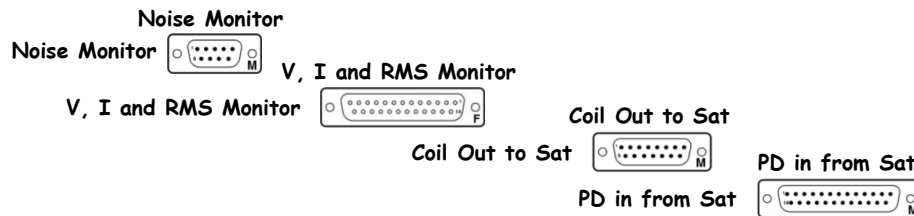

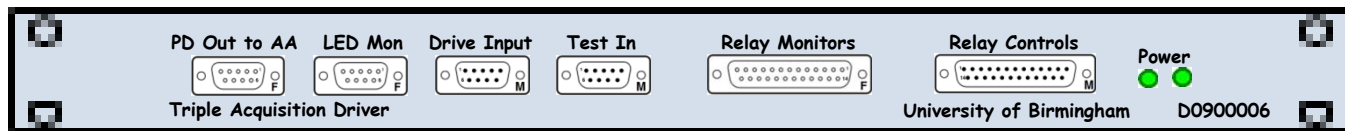

[D0901047](#)
[D070480](#)
Front

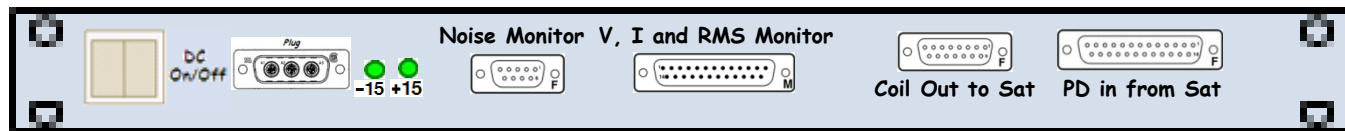
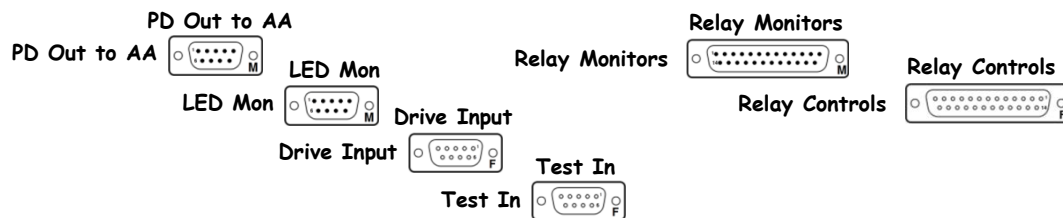

[S1001188](#)
Rear

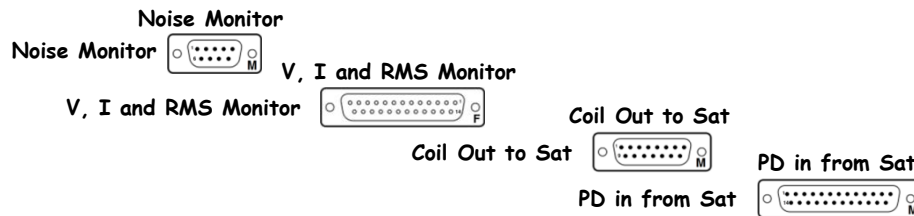

BIO1 Binary Output Chassis D1000725 S1101781 ±18@0.5A

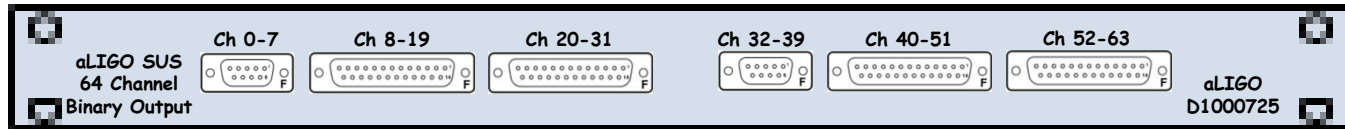
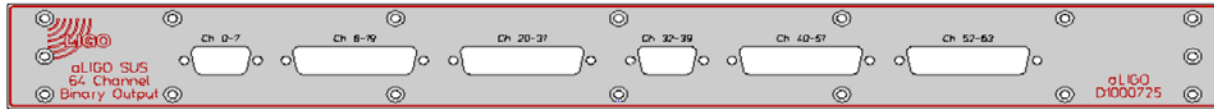

[D1000725](#)

Front

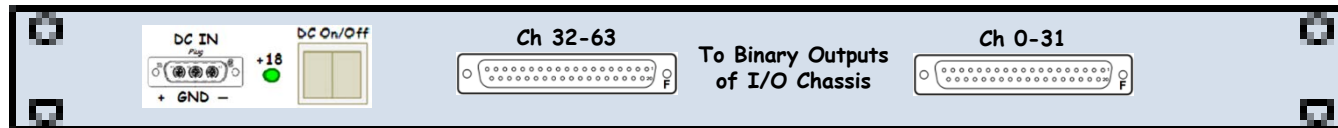
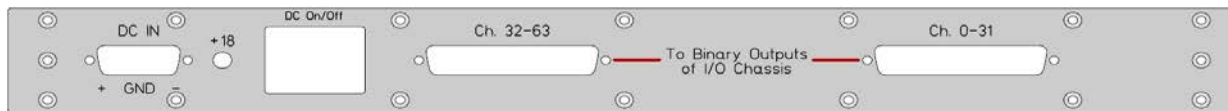
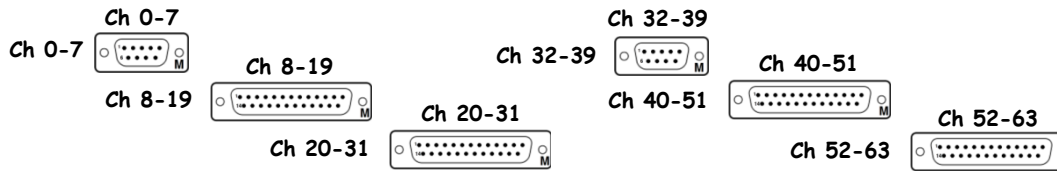

[S1101781](#)

Rear



BIO1 Binary Input Chassis D1000726 S1101805 ±18@0.5A

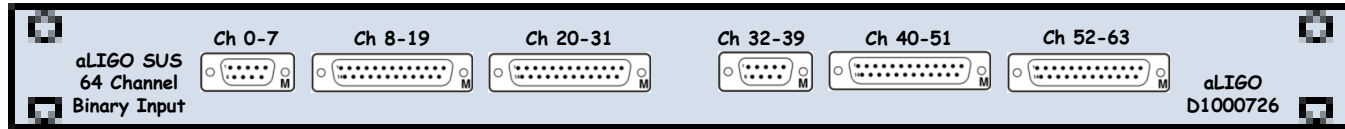
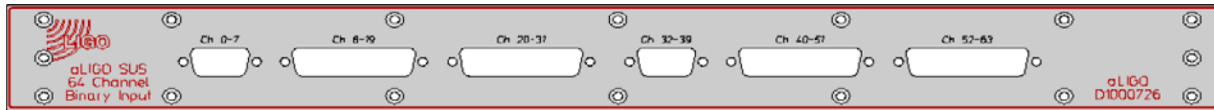

D1000726

Front

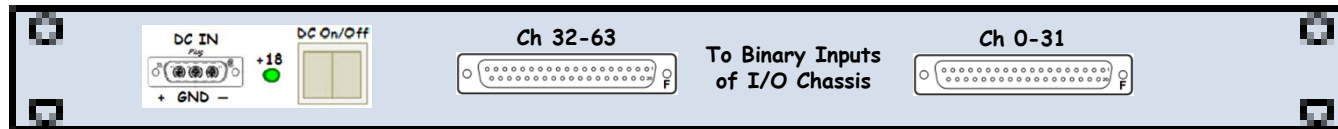
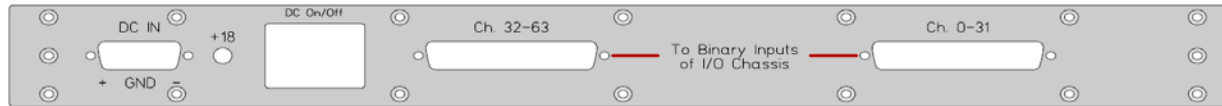
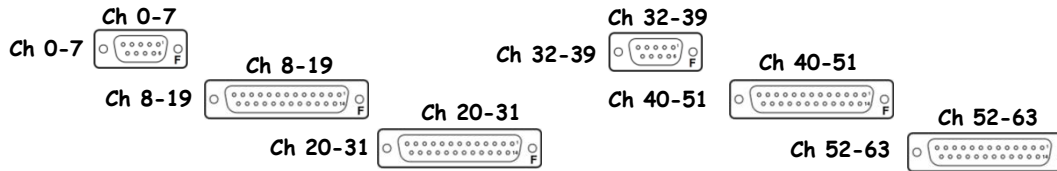

S1101805

Rear



BI02 Binary Output Chassis D1000725 S1101782 ±18@0.5A

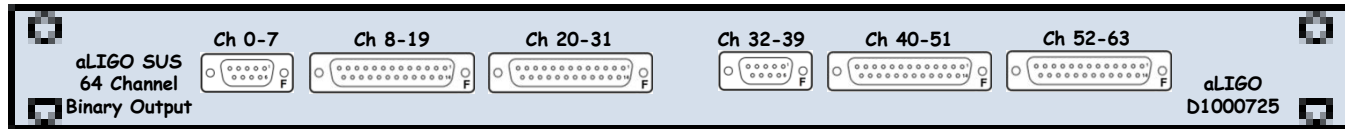
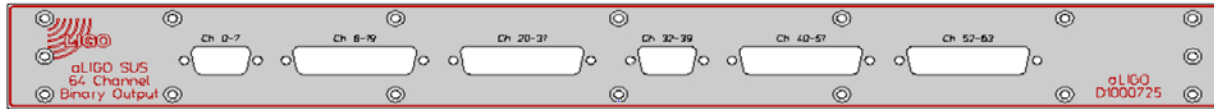

[D1000725](#)

Front

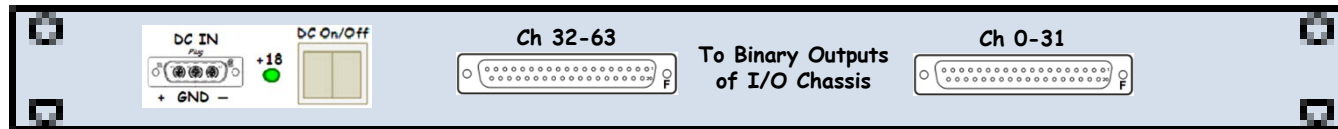
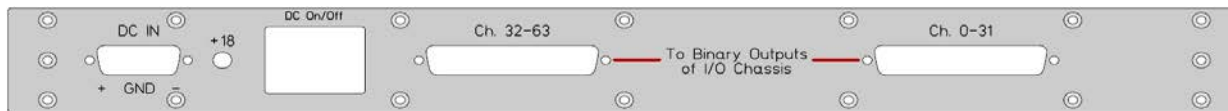
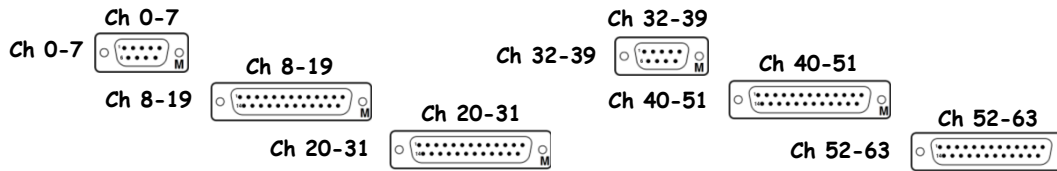

[S1101782](#)

Rear



BIO2 Binary Input Chassis D1000726 S1101802 ±18@0.5A

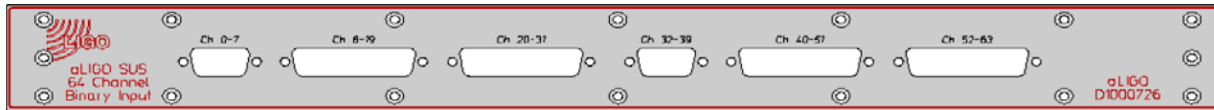

[D1000726](#)

Front

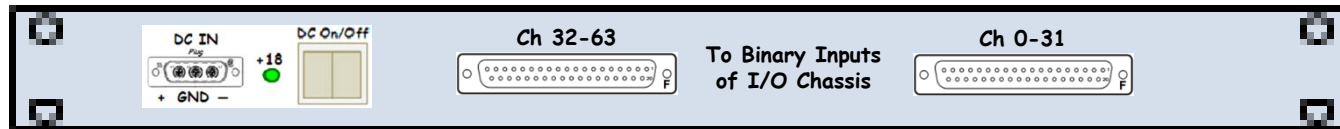
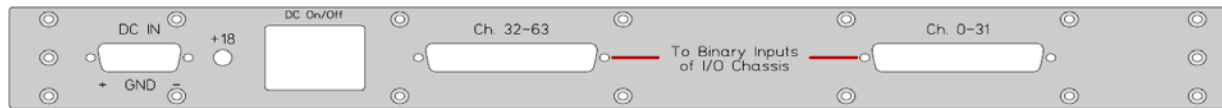
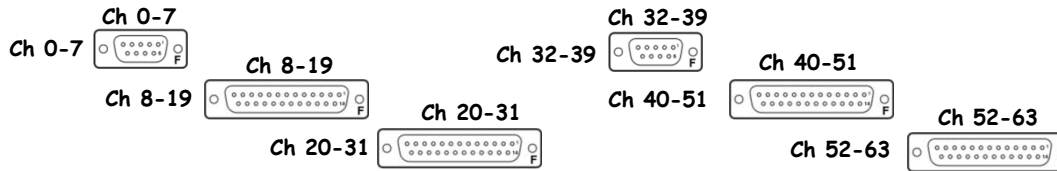

[S1101802](#)

Rear



L1-SUS-C2 Details

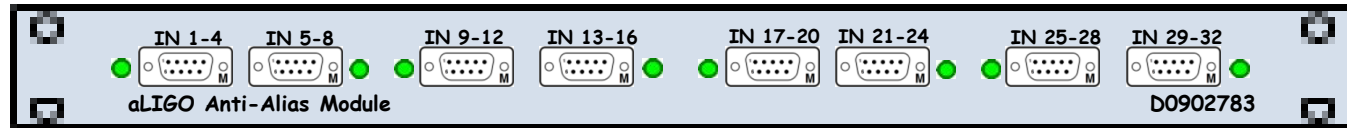
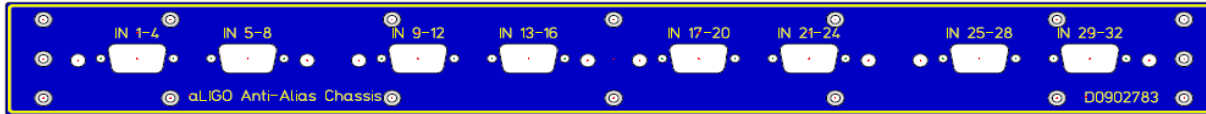

D0902783

Front

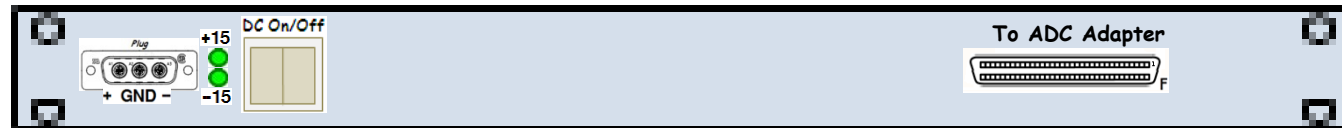
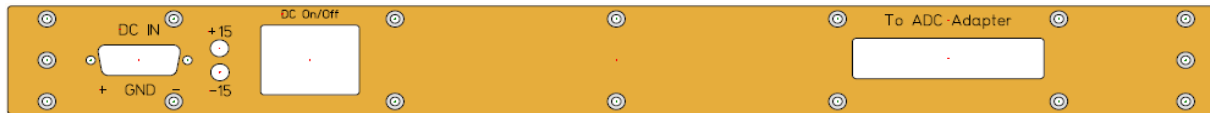
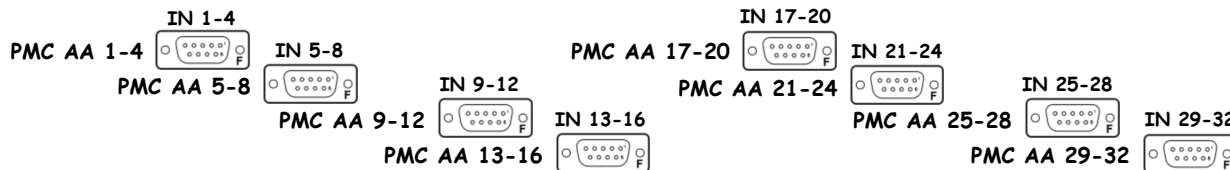

S1105129

Rear



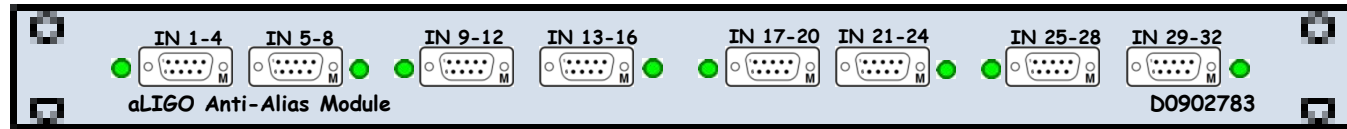
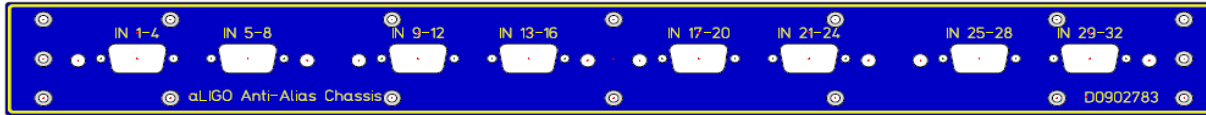

D0902783

Front

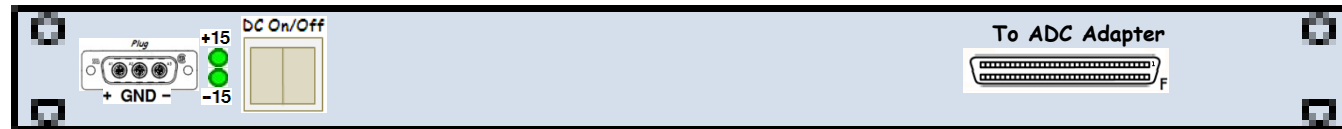
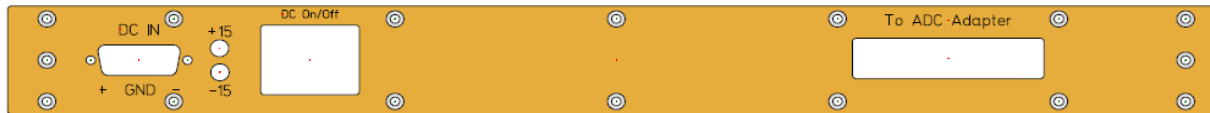
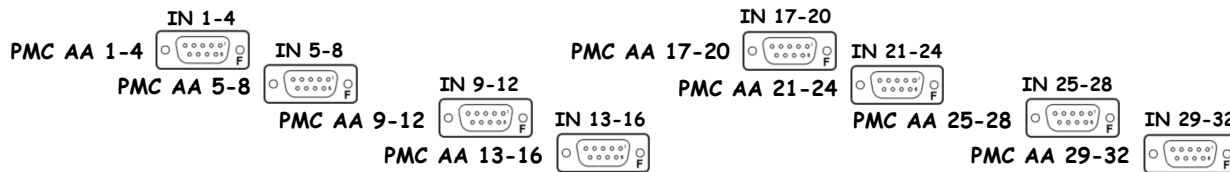

S1105149

Rear



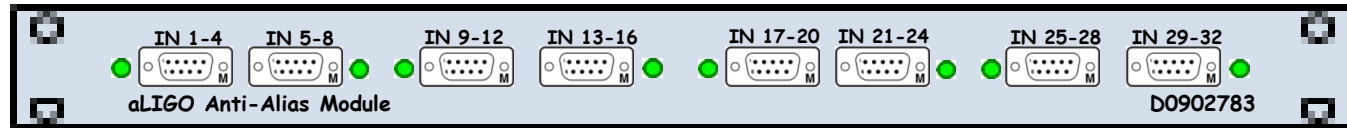
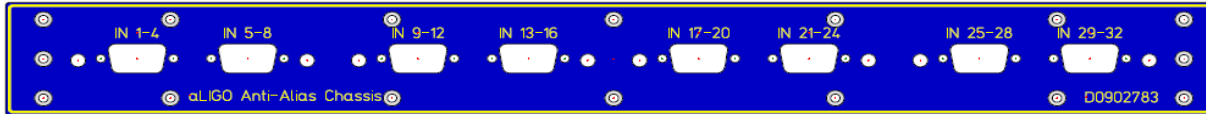

D0902783

Front

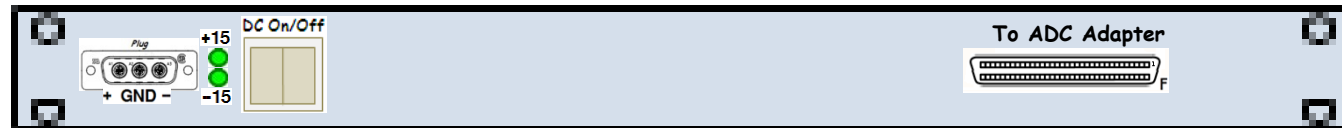
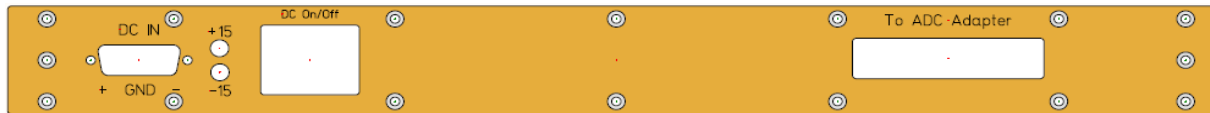
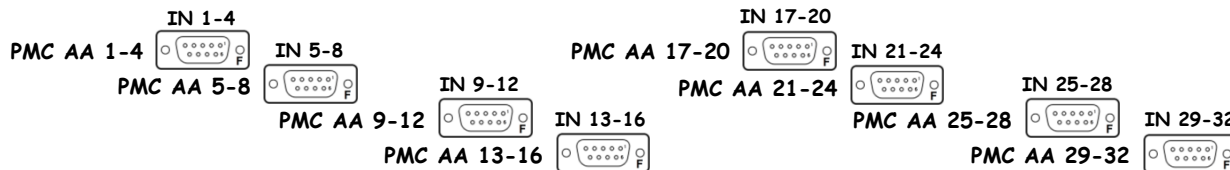

S1105148

Rear



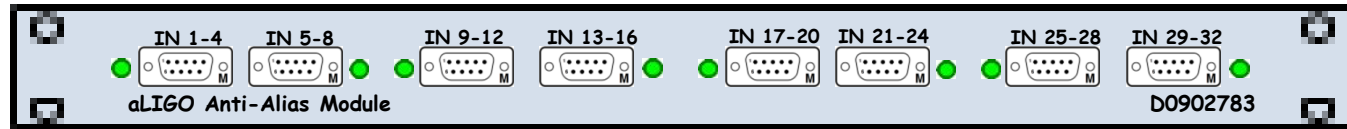
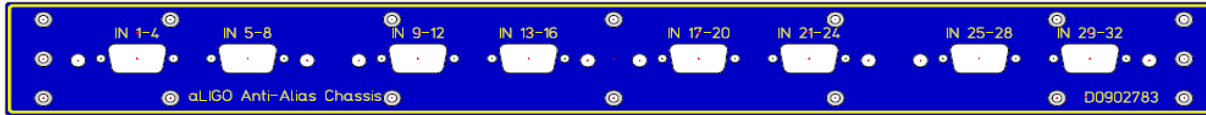

D0902783

Front

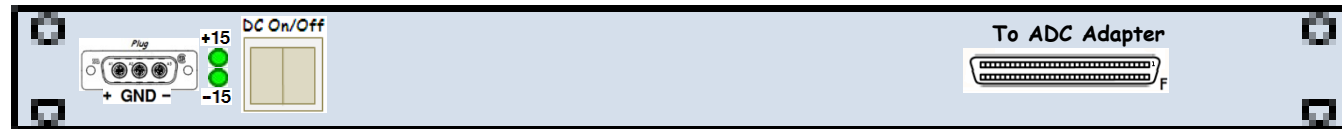
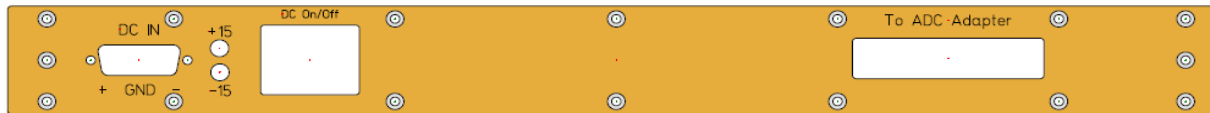
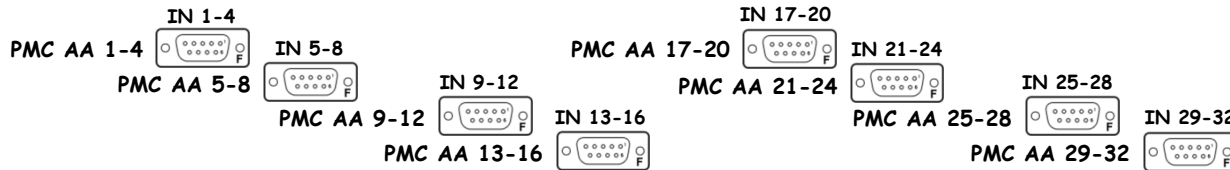

S1105147

Rear



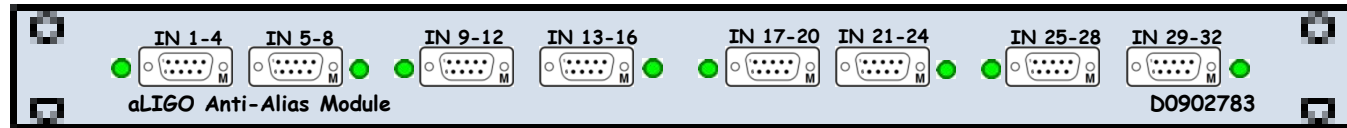
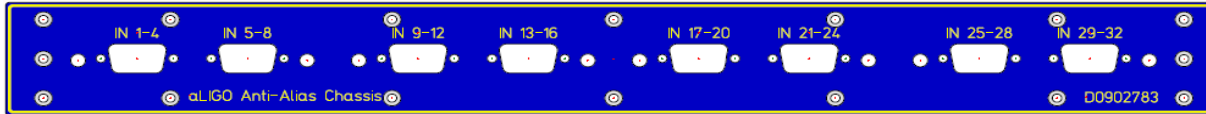

D0902783

Front

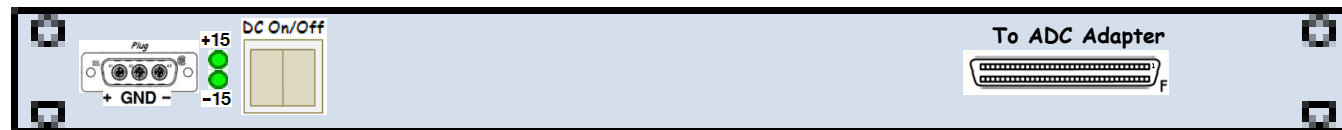
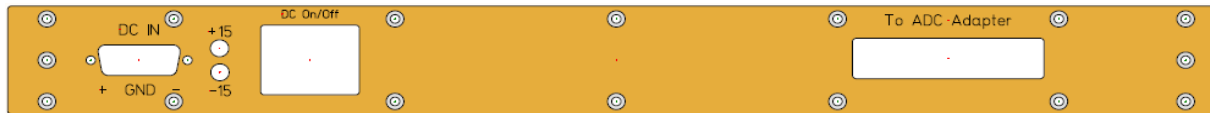
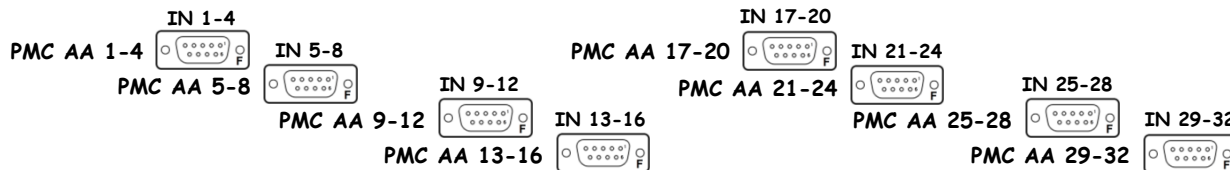

S1105146

Rear



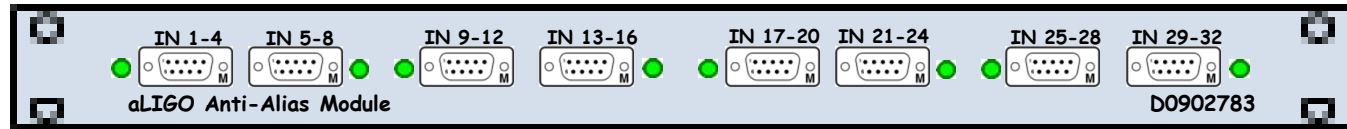
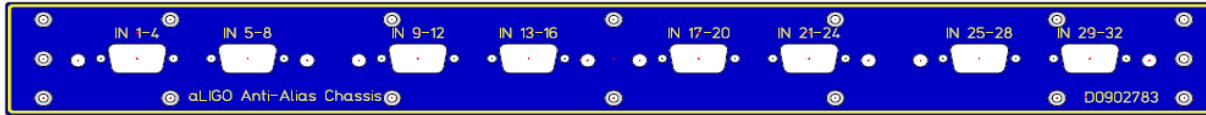

D0902783

Front

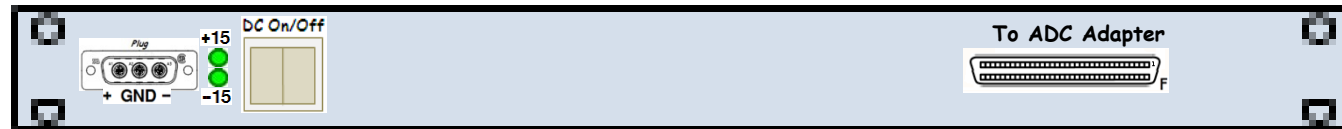
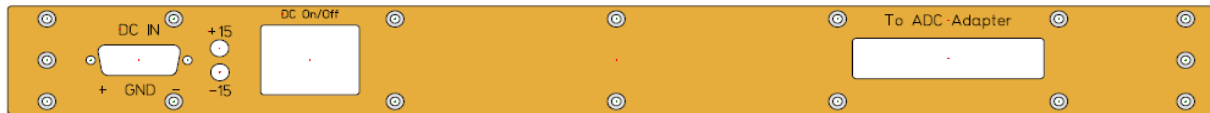
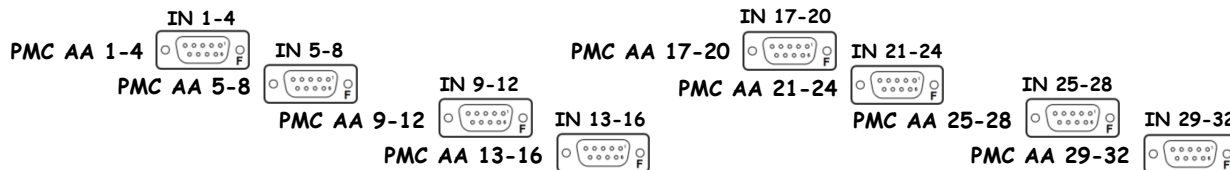

S1105145

Rear





D1001715

Front

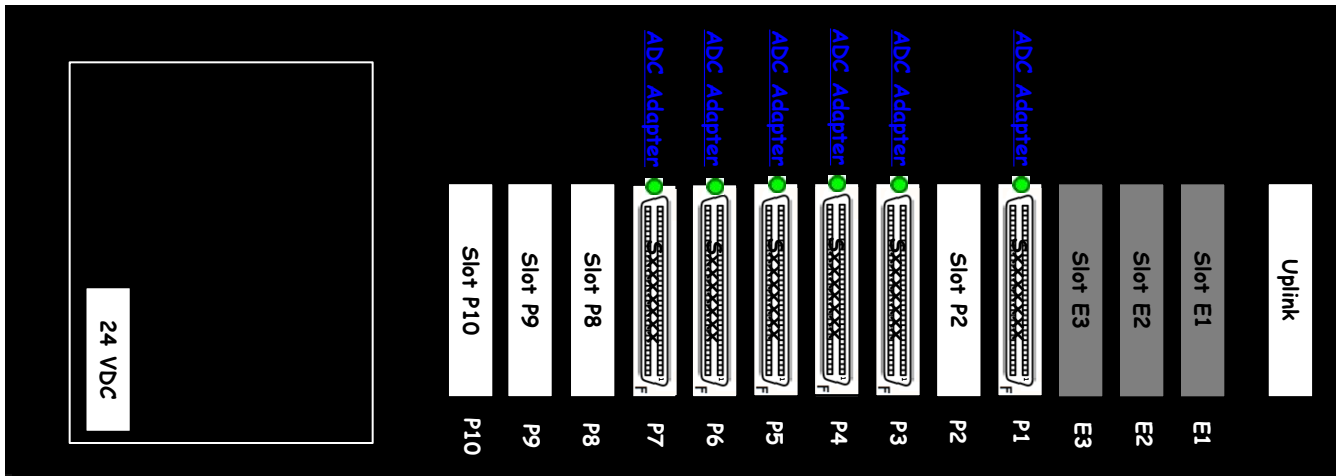

S1001141

Rear

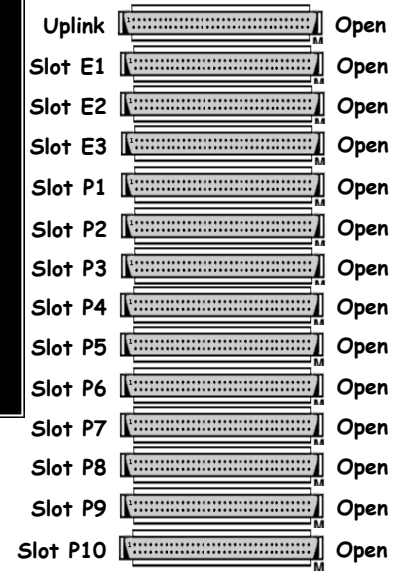

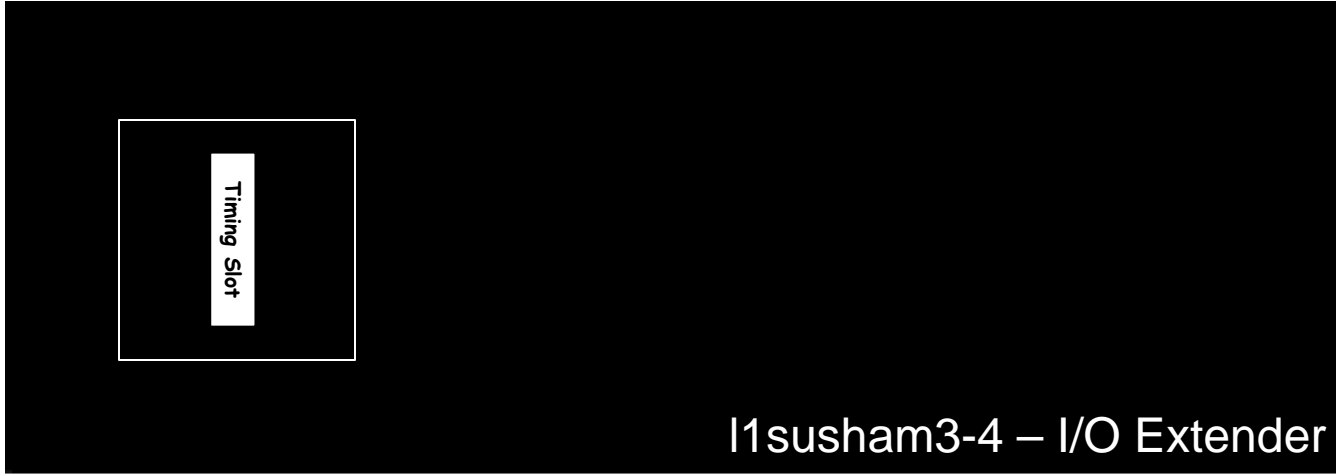

D1001715

Front

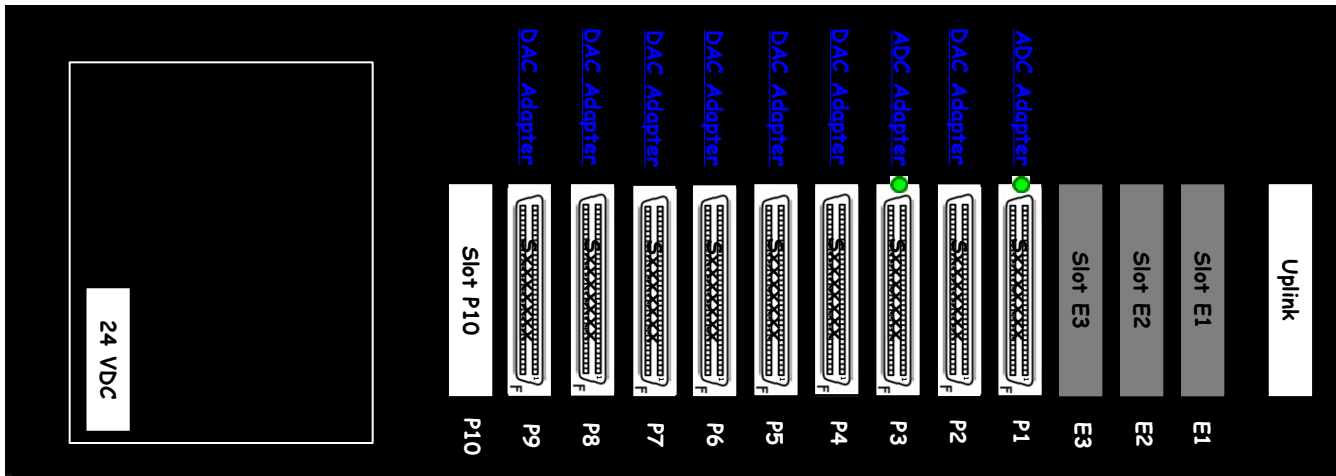

S1001140

Rear

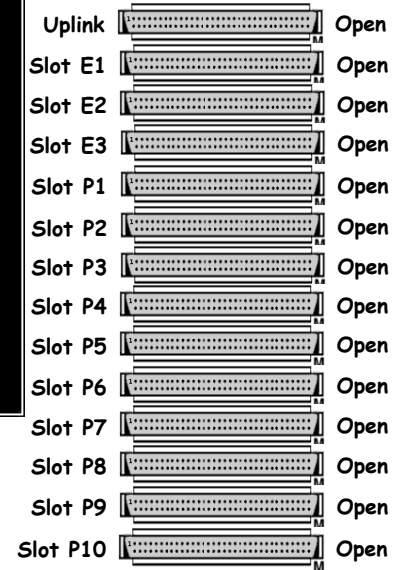

L1-SUS-C3 Details

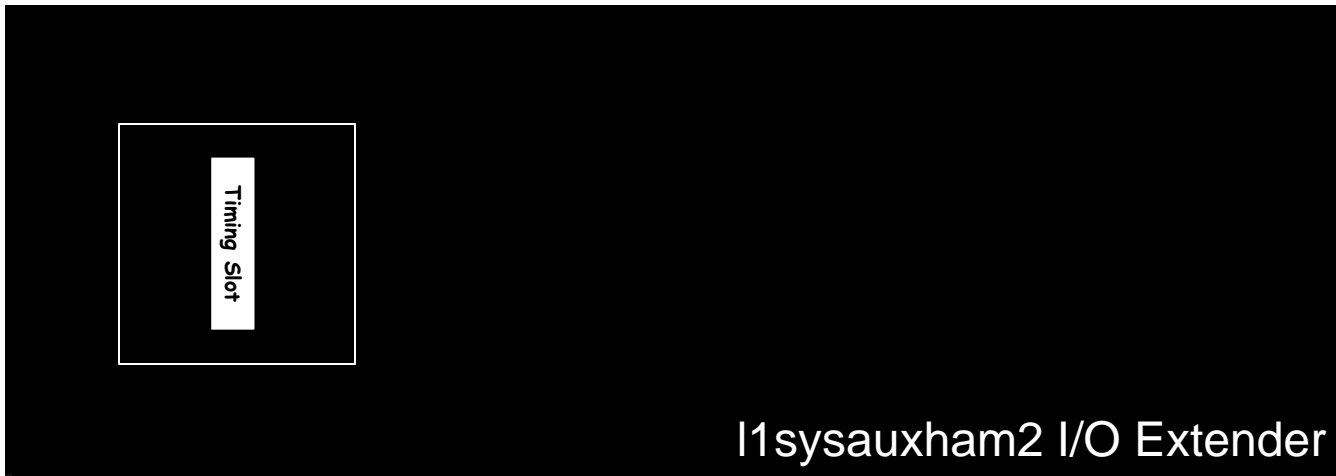

[D1001715](#)

Front

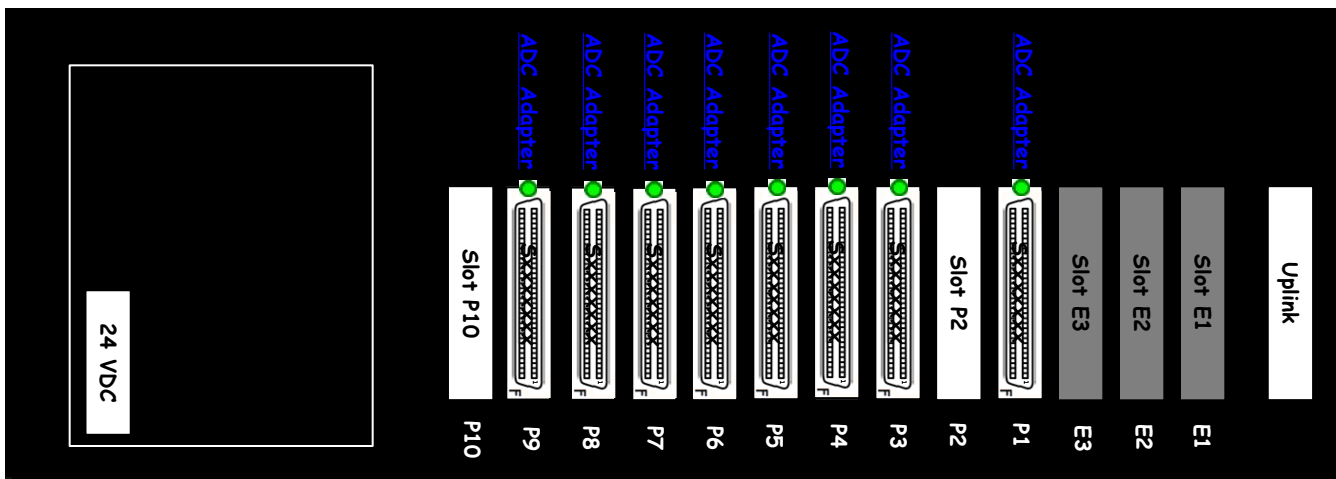

[S1003891](#)

Rear

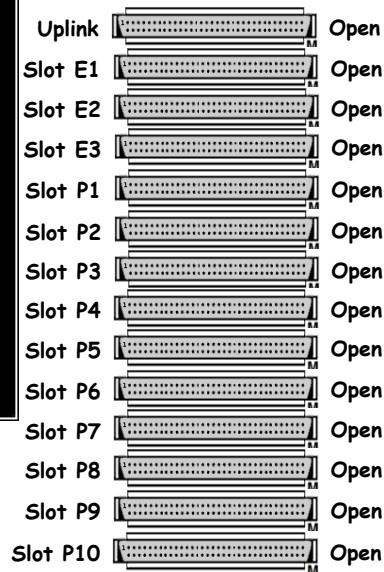



[D1001715](#)

Front

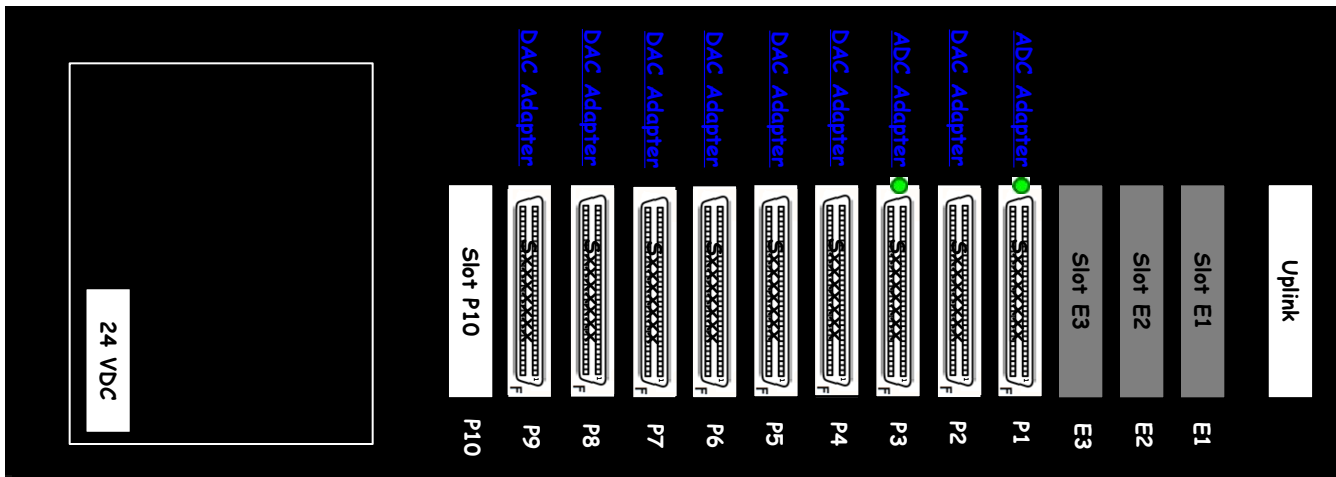

[S1001133](#)

Rear

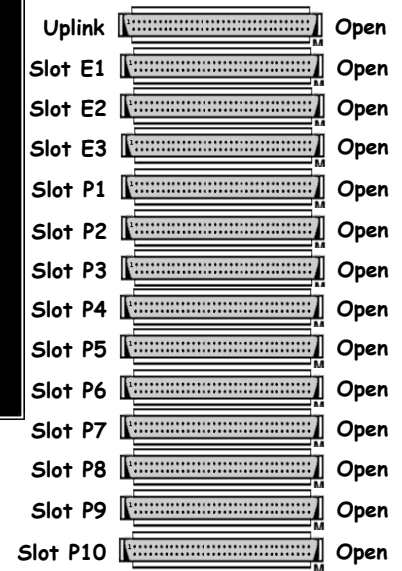



D1001715

Front

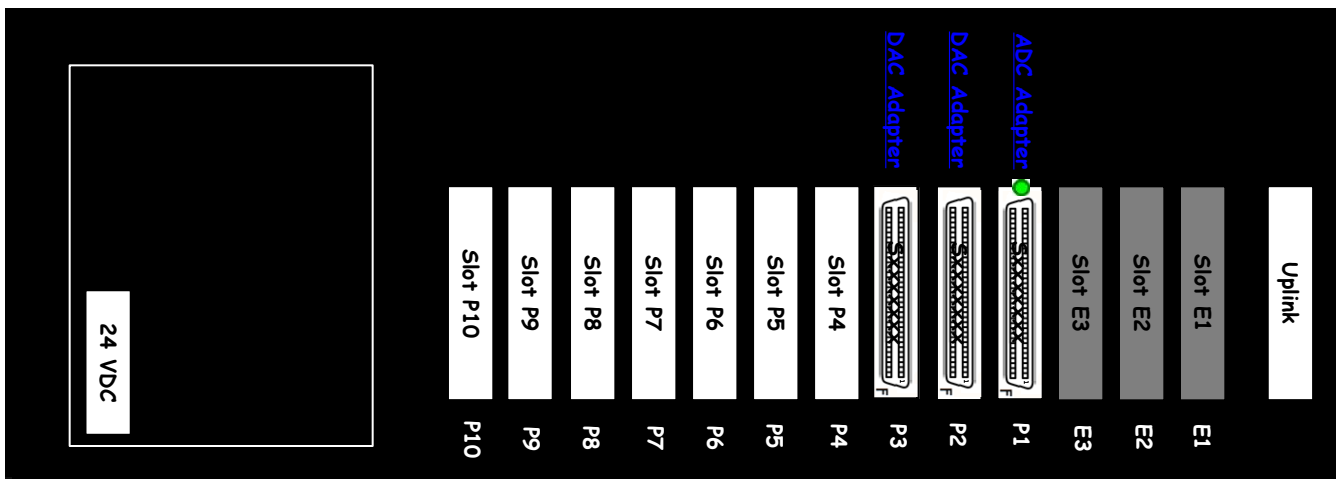

S1001139

Rear

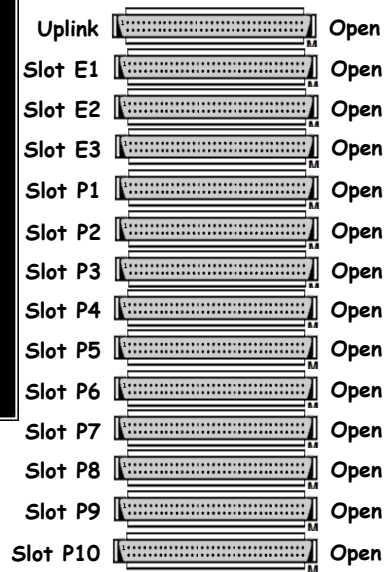

Binary Input Chassis D1001726 Sxxxxxxx ±18@0.5A

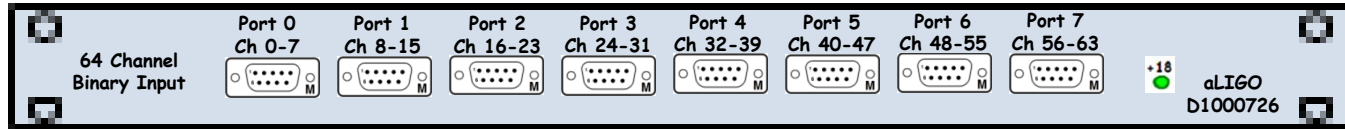
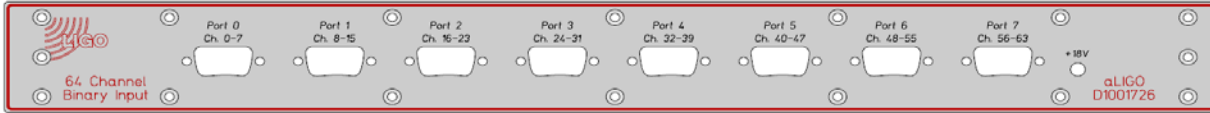

D1001726

Front

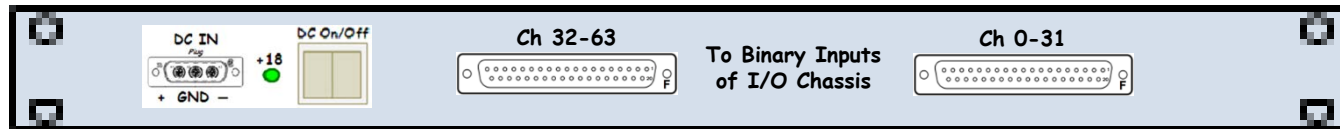
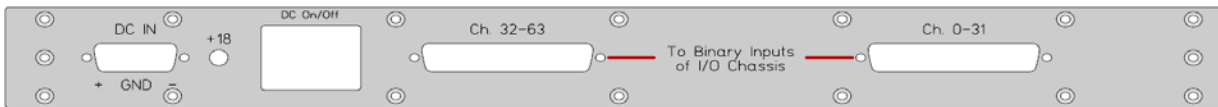
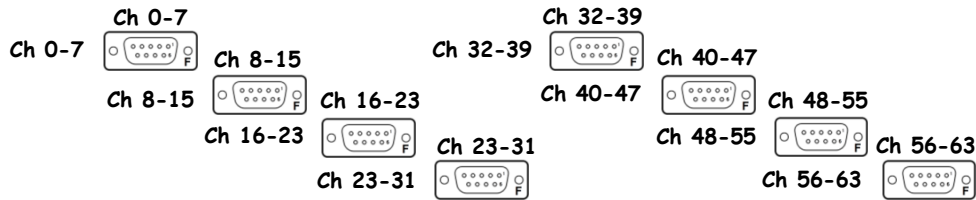

Sxxxxxxx

Rear



Binary Output Chassis ±18@0.5A

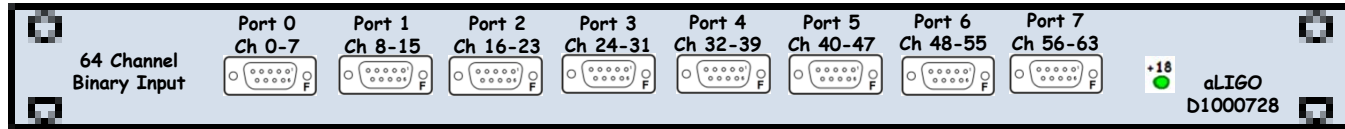
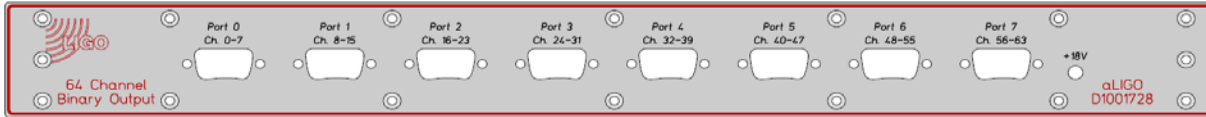

D1001728

Front

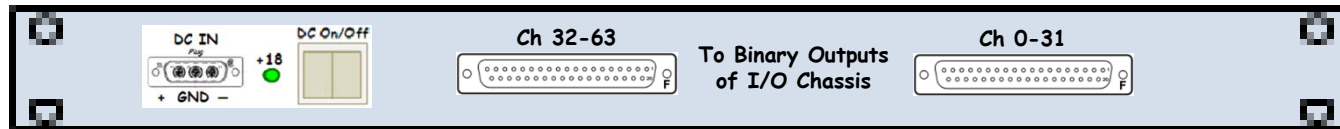
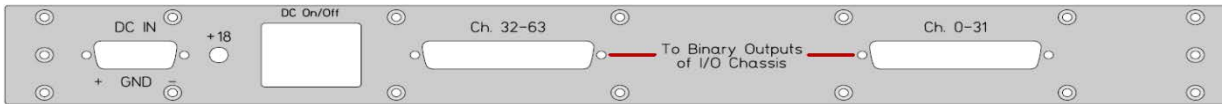
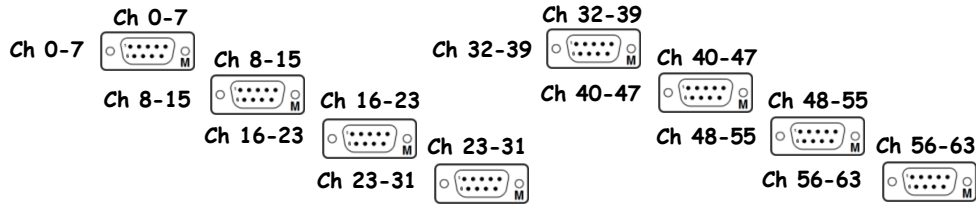

Sxxxxxxx

Rear



L1-SUS-C4 Details

D1001242 - S1000253



<< L1-SUS-C4

MC1-MC3 Triple Top Coil Driver Chassis D1001242 S1000253 ±18@0.5A

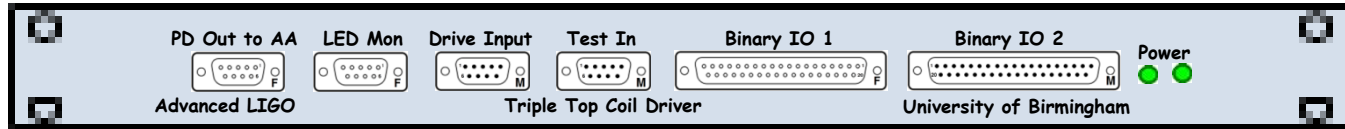

[D0902747](#)
[D070480](#)
Front

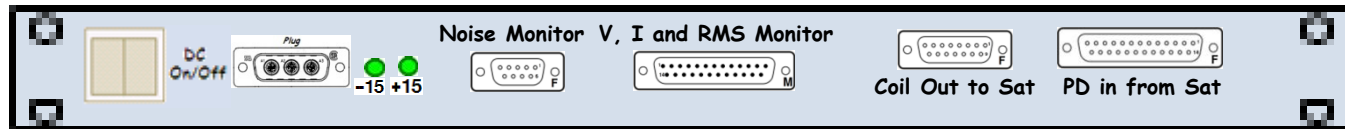
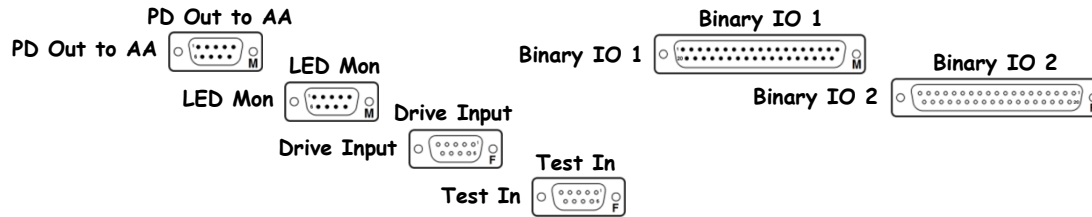

[S1000253](#)
Rear

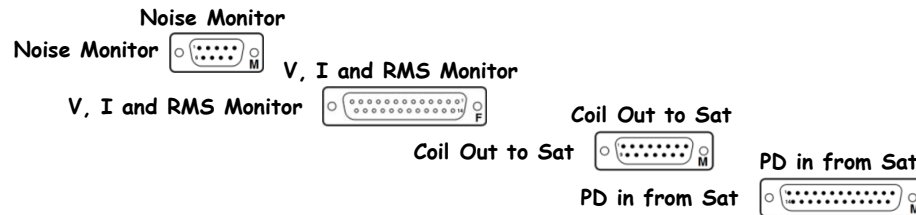

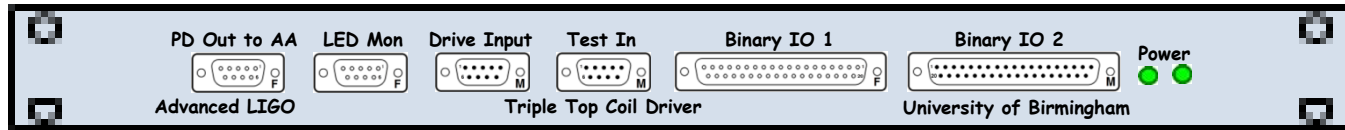

[D0902747](#)
[D070480](#)
 Front

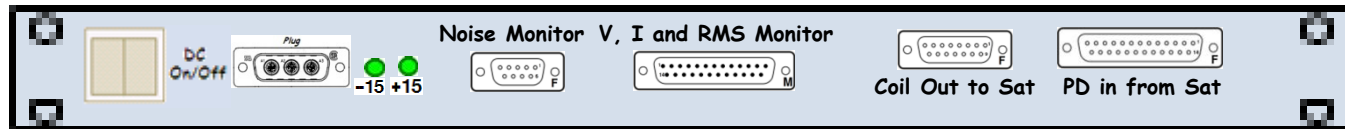
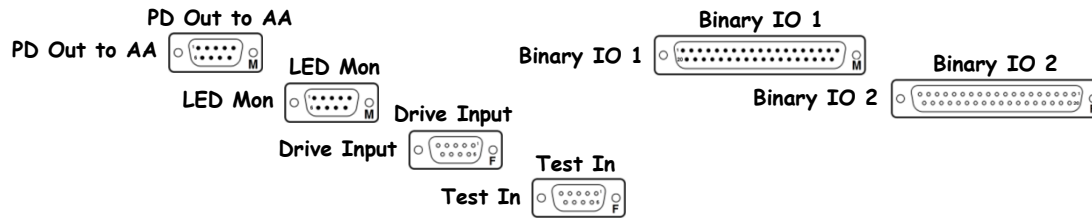

[S1000261](#)
 Rear

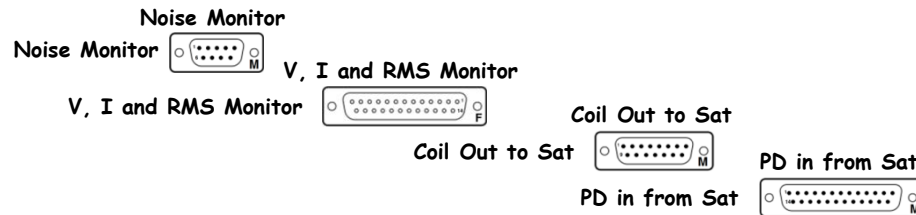

D1001242 - S1000262



<< L1-SUS-C4

MC1-MC3 Triple Top Coil Driver Chassis D1001242 S1000262 ±18@0.5A

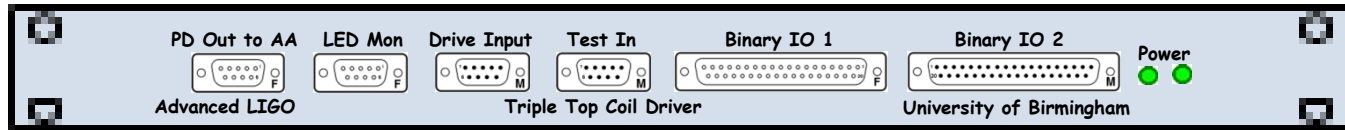

[D0902747](#)
[D070480](#)
Front

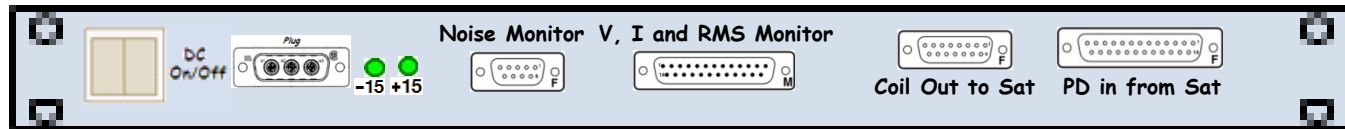
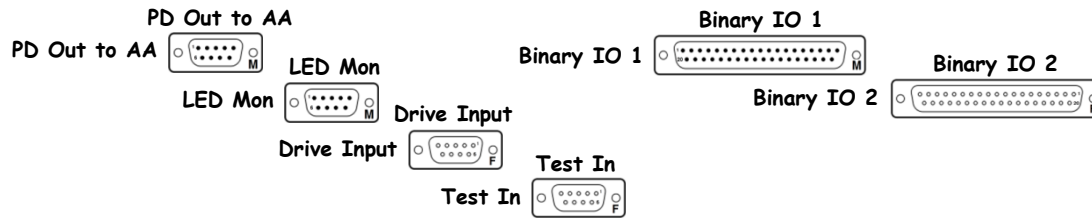

[S1000262](#)
Rear

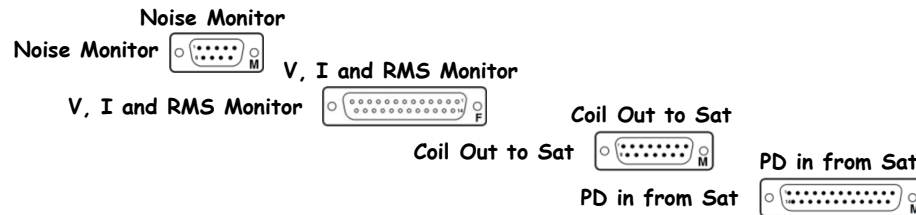

D1001242 - S1000257



<< L1-SUS-C4

PRM-PR3 Triple Top Coil Driver Chassis D1001242 S1000257 ±18@0.5A

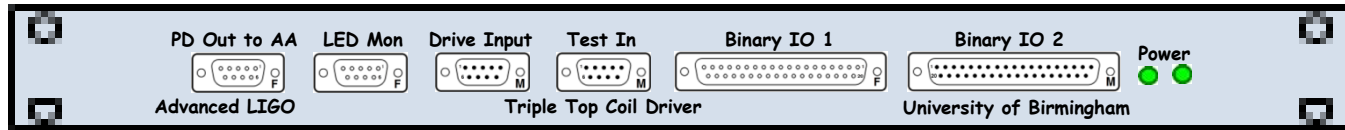

[D0902747](#)
[D070480](#)
Front

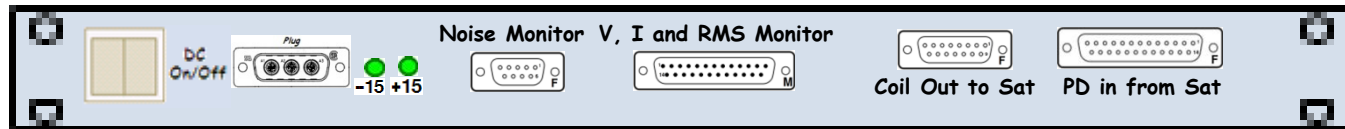
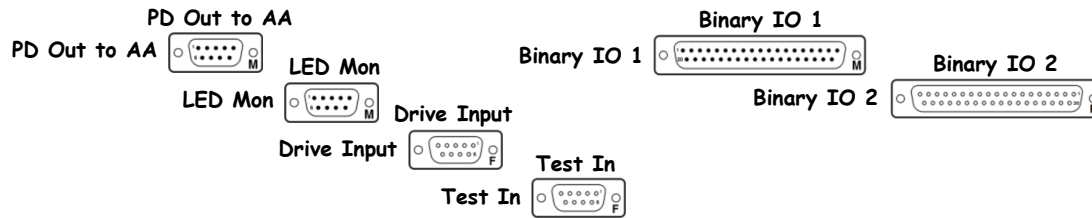

[S1000257](#)
Rear

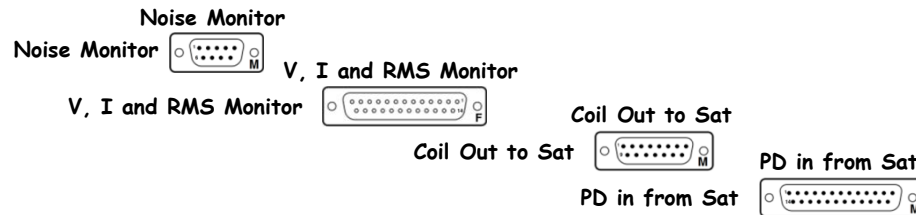

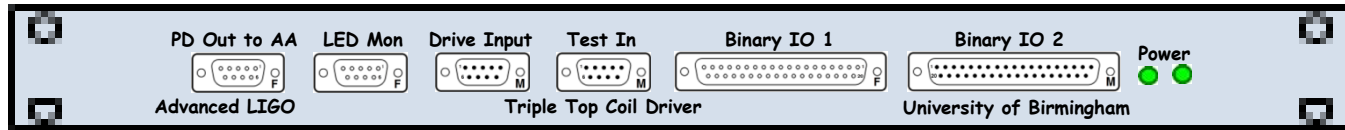

[D0902747](#)
[D070480](#)
Front

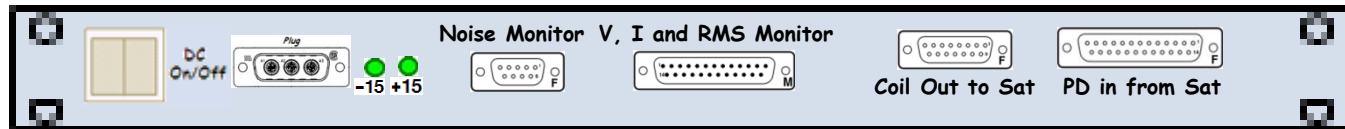
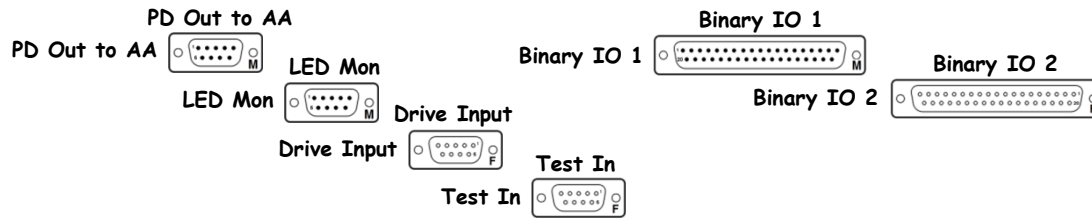

[S1000259](#)
Rear

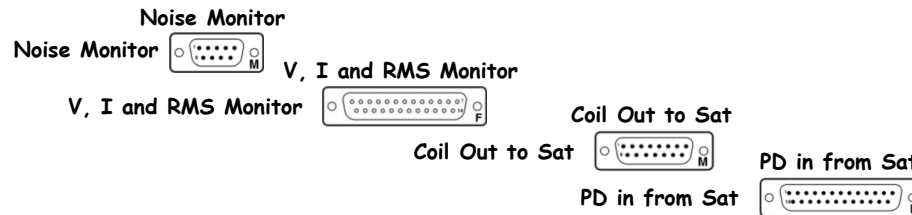

D1001242 - S1000723



<< L1-SUS-C4

PRM-PR3 Triple Top Coil Driver Chassis D1001242 S1000723 ±18@0.5A

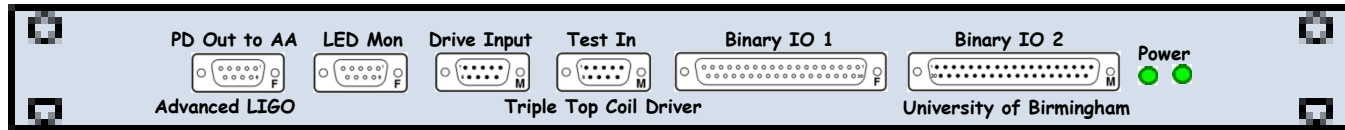

[D0902747](#)
[D070480](#)
Front

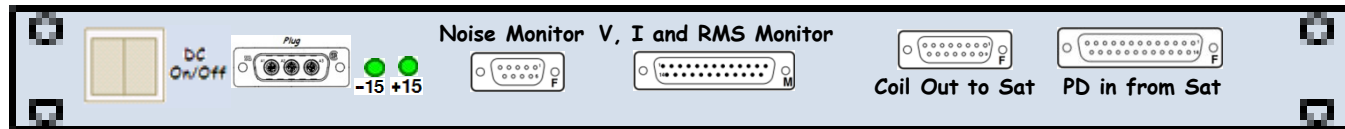
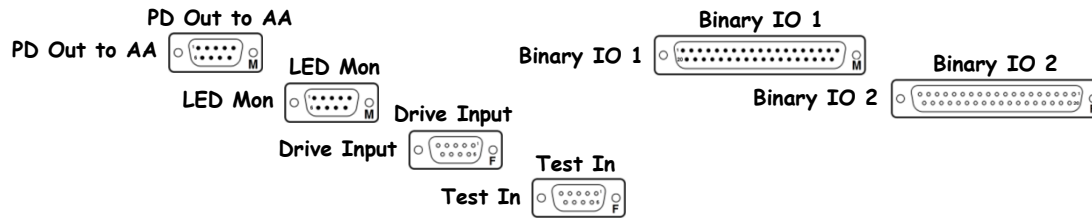

[S1000723](#)
Rear

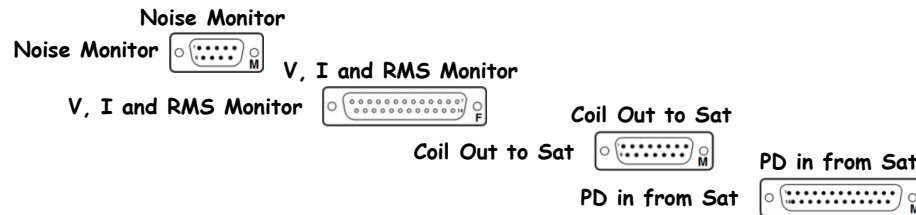

L1-SUS-C5 Details

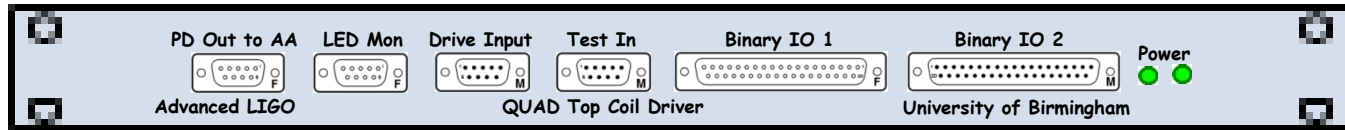

[D0902747](#)
[D070480](#)
Front

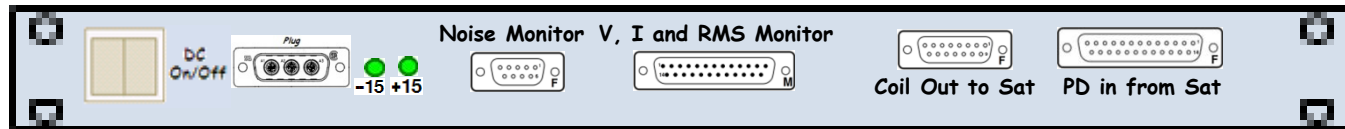
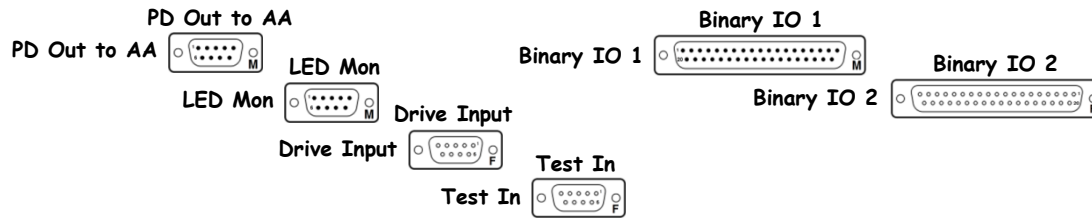

[S1000376](#)
Rear

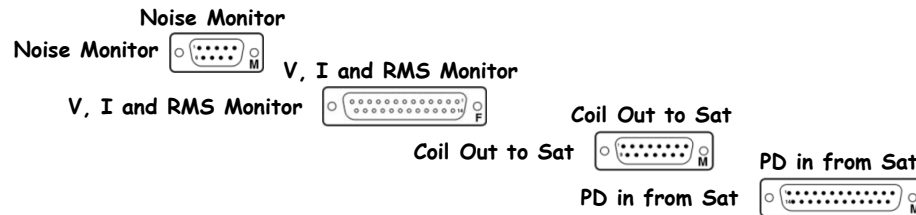

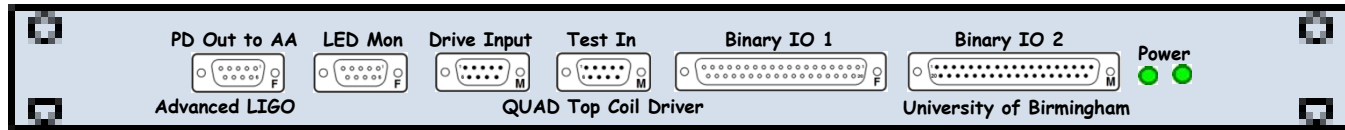

[D0902747](#)
[D070480](#)
Front

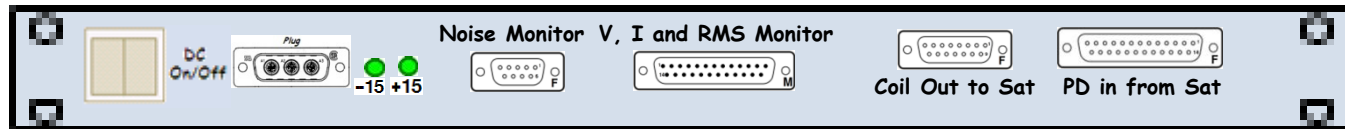
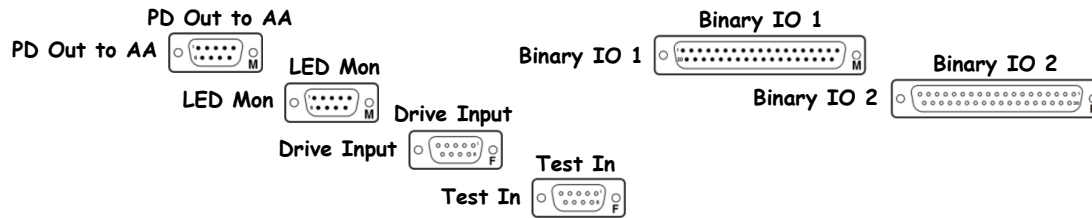

[S1000376](#)
Rear

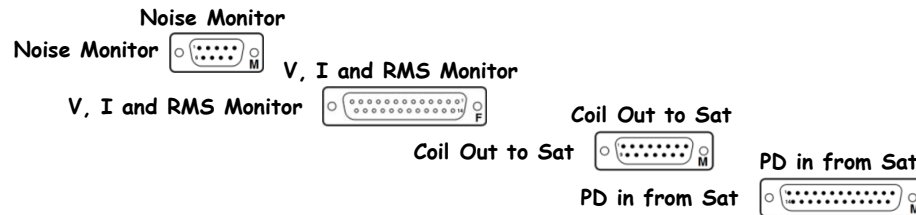

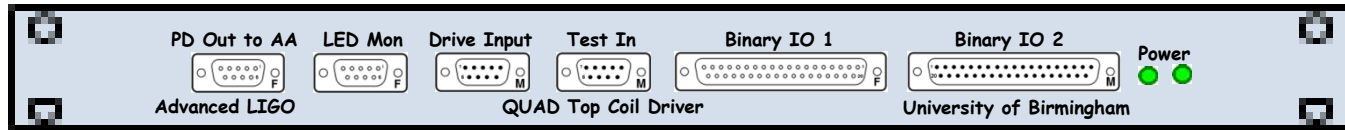

[D0902747](#)
[D070480](#)
Front

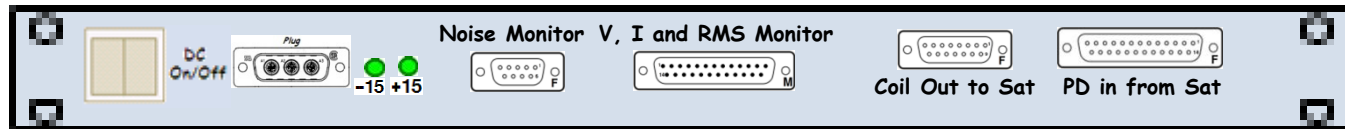
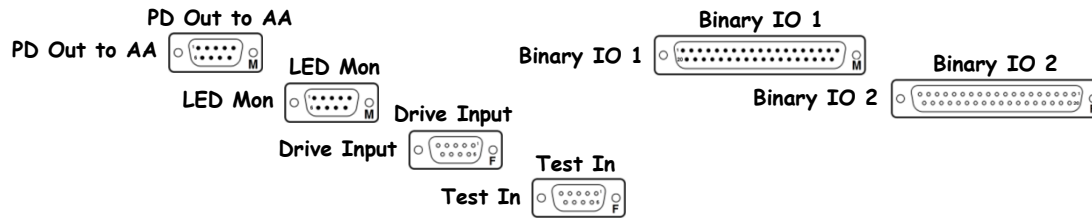

[S1000376](#)
Rear

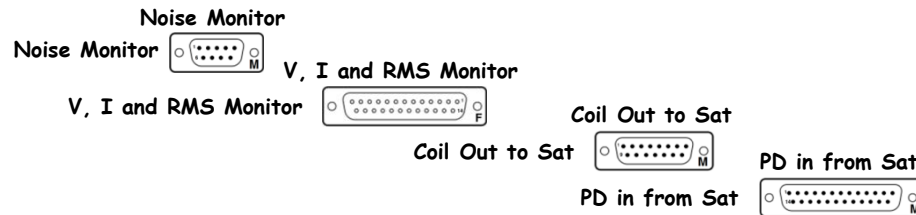

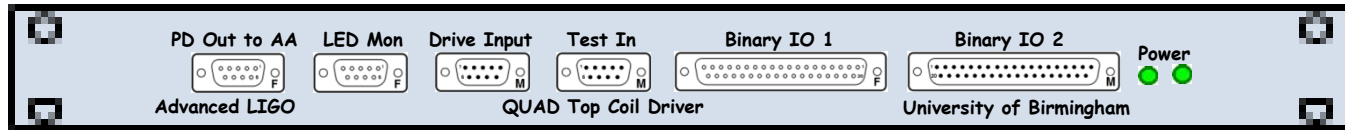

[D0902747](#)
[D070480](#)
Front

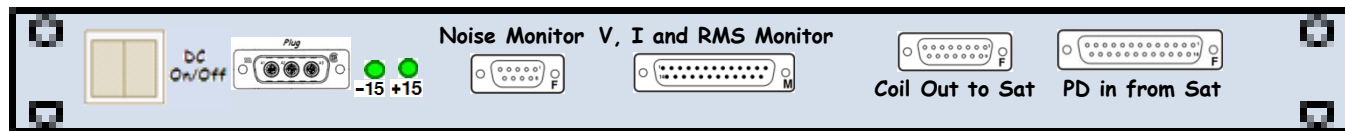
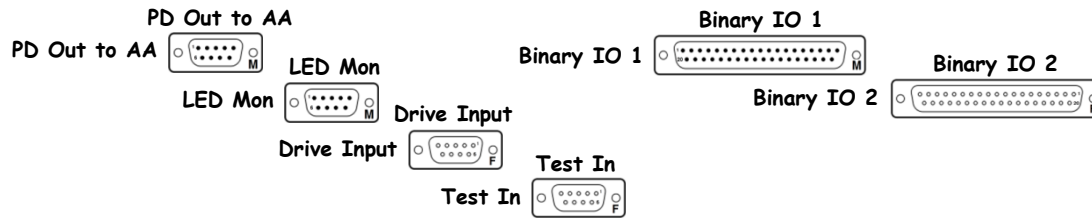

[S1000376](#)
Rear

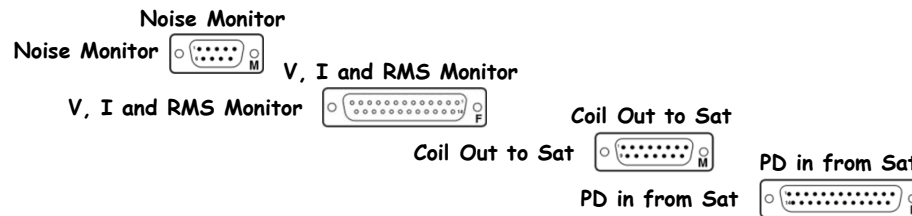

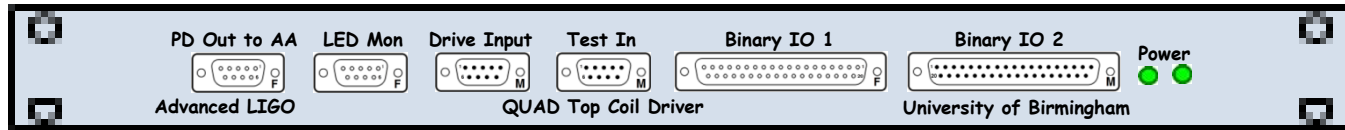

[D0902747](#)
[D070480](#)
 Front

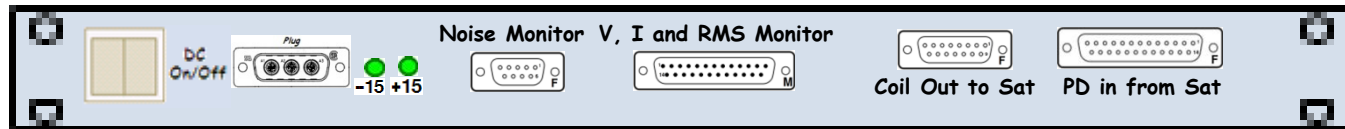
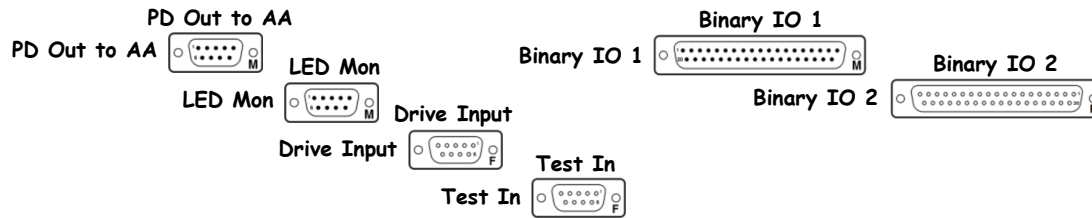

[S1000376](#)
 Rear

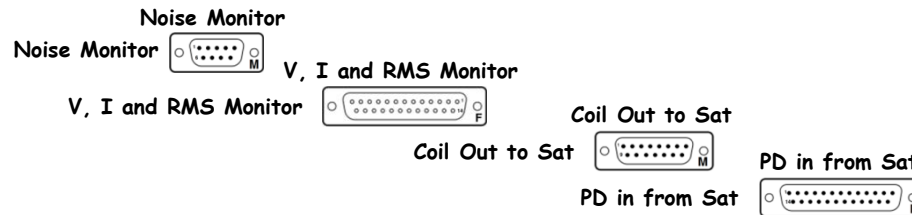

ITMX Quad Top Coil Driver Chassis D1001782 S1000372 ±18@0.5A

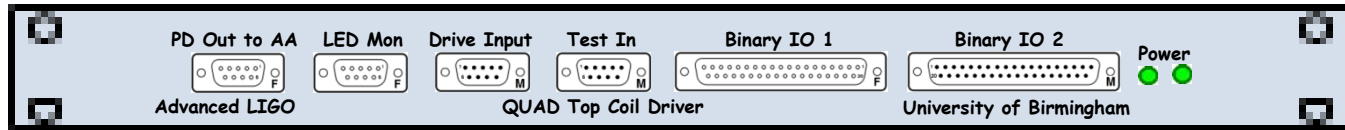

[D0902747](#)
[D070480](#)
Front

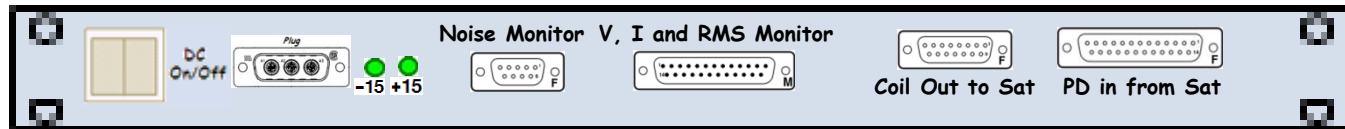
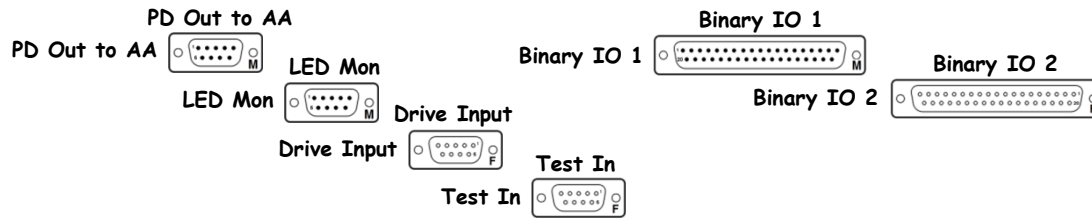

[S1000376](#)
Rear

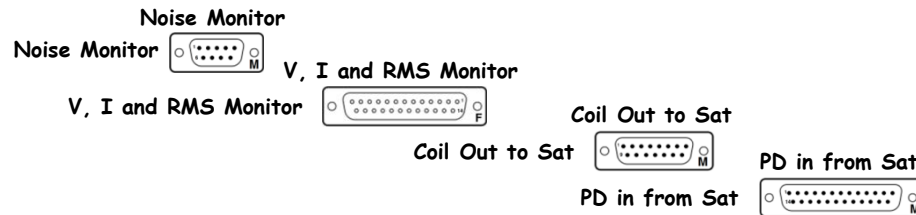

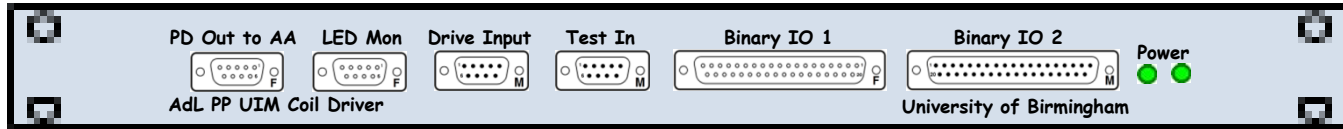

[D070481](#)
[D070480](#)
Front

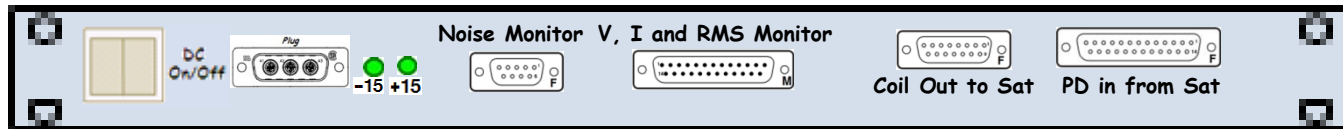
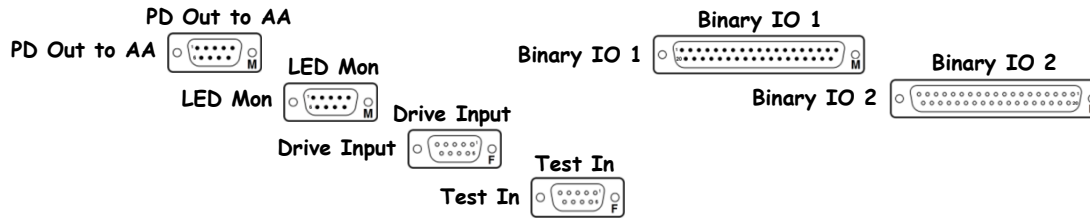

[S1000376](#)
Rear

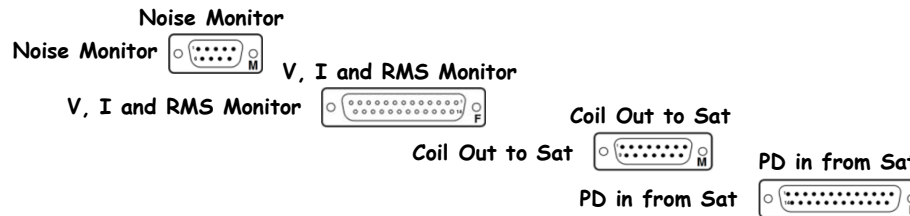

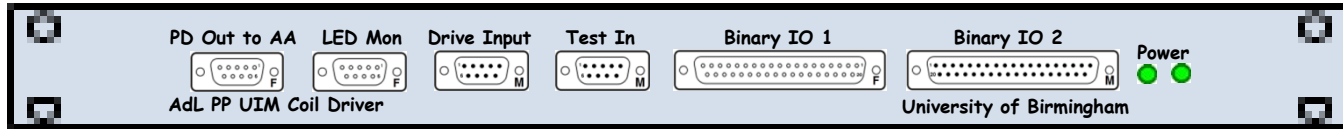

[D070481](#)
[D070480](#)
Front

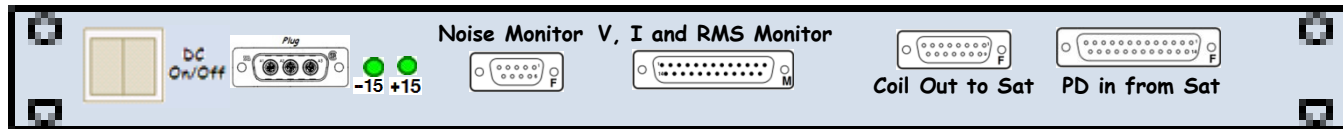
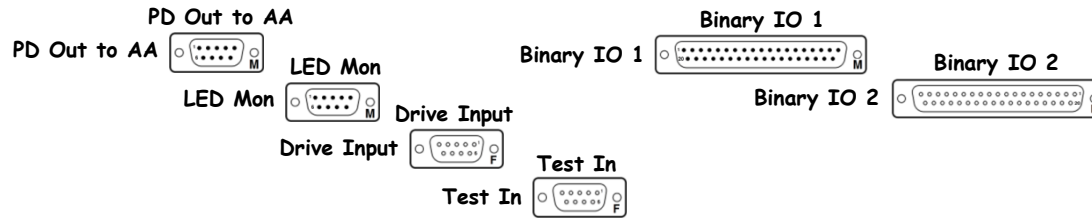

[S1000376](#)
Rear

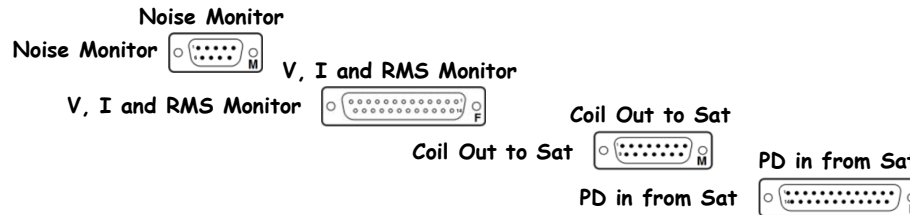

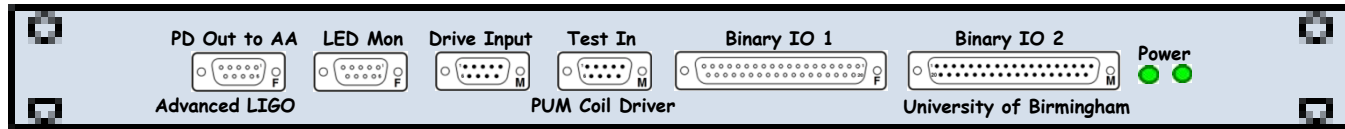

[D070483](#)
[D070480](#)
Front

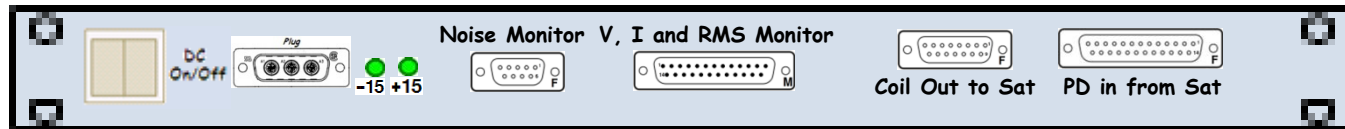
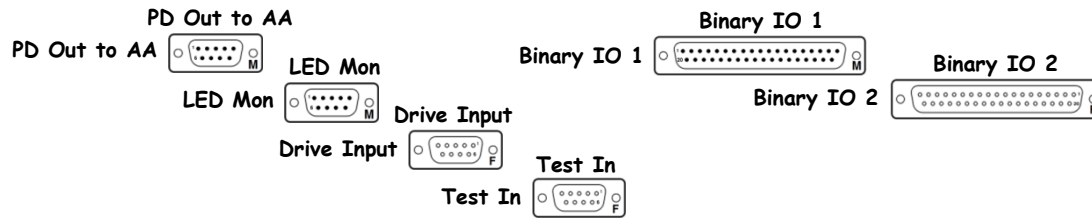

SN:
Rear

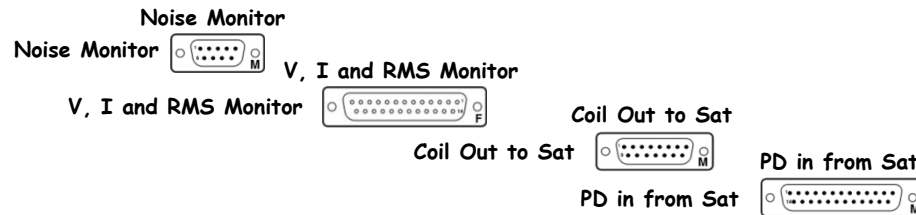

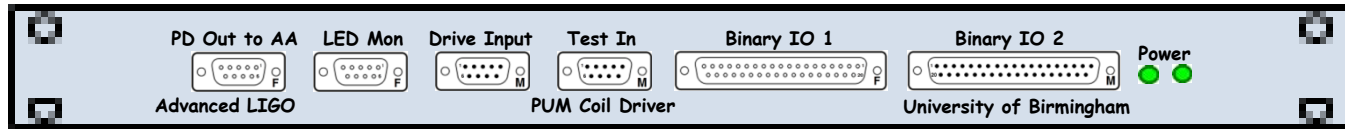

[D070483](#)
[D070480](#)
Front

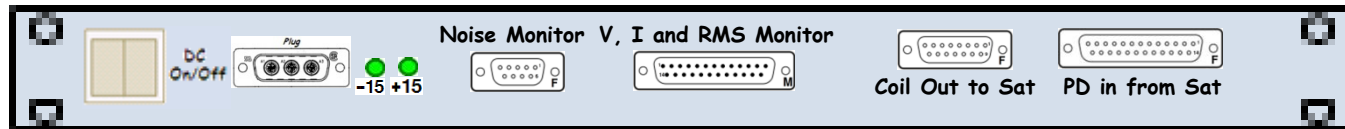
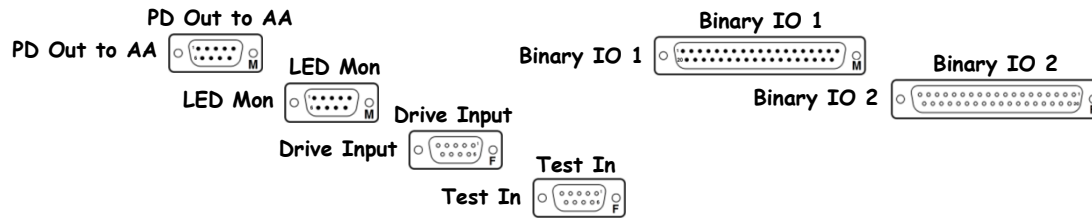

SN:
Rear

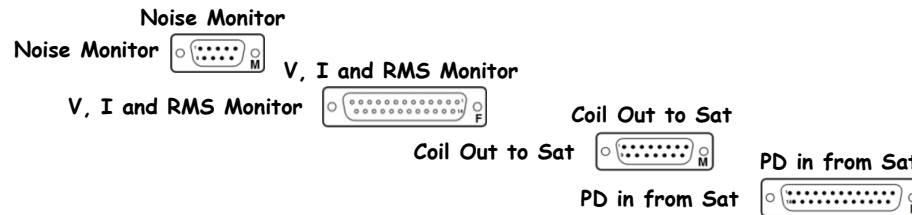

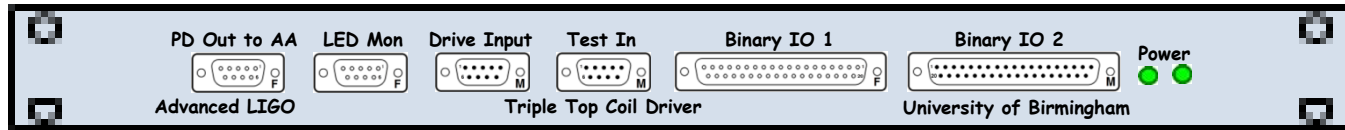

[D0902747](#)
[D070480](#)
Front

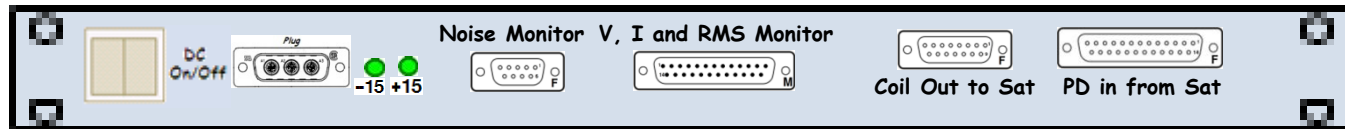
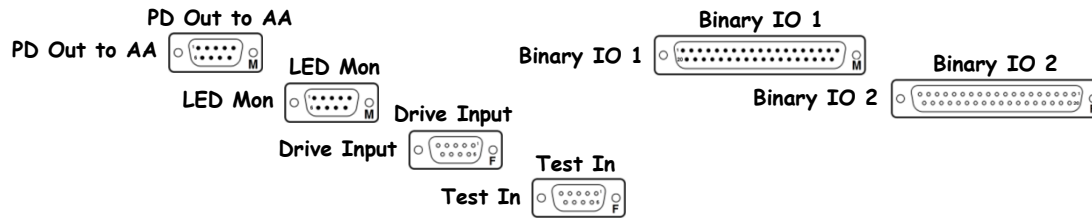

[S1000722](#)
Rear

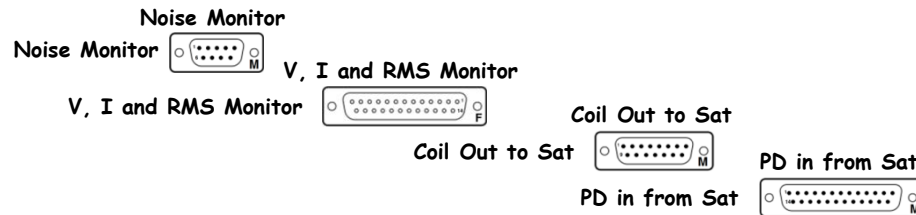

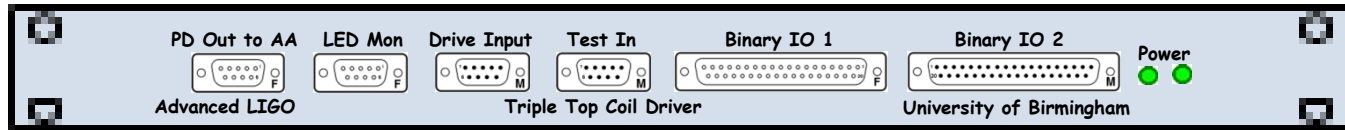

[D0902747](#)
[D070480](#)
Front

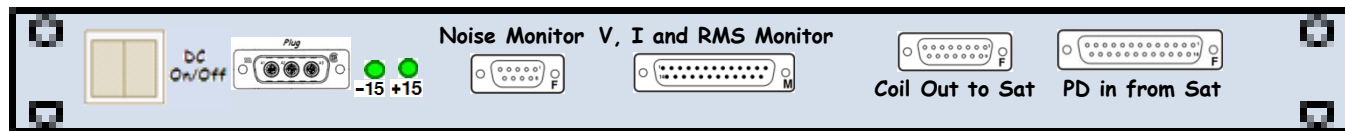
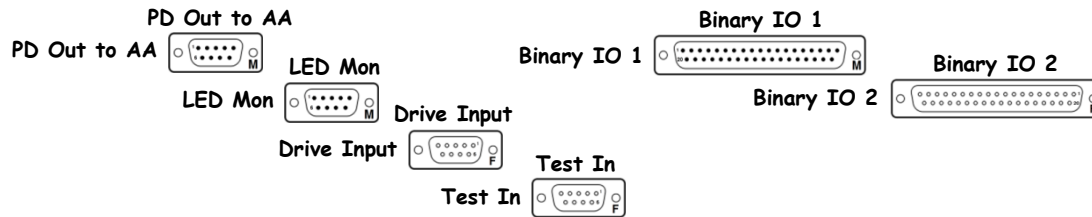

[S1000273](#)
Rear

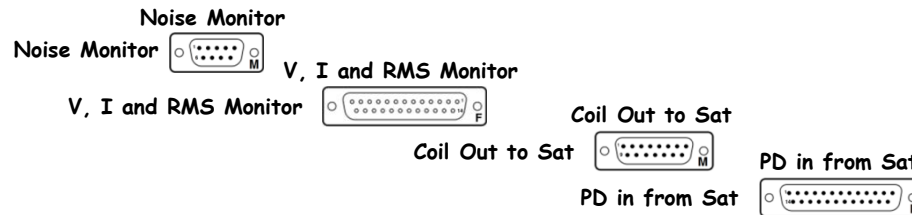

This number is actually correct. The DocDB part number is erroneously D090006 because it got assigned before the Wizards decided there would be 5 digits, and they won't fix it. I've asked.

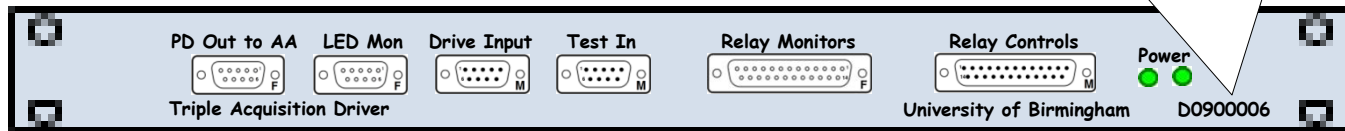

[D0901047](#)
[D070480](#)
Front

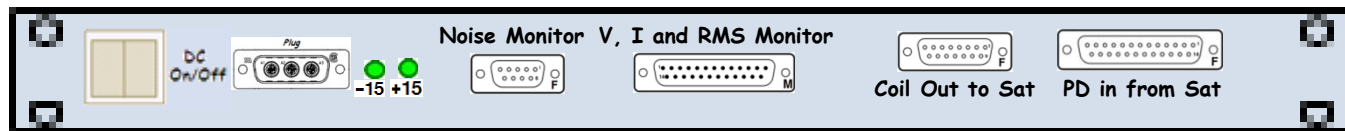
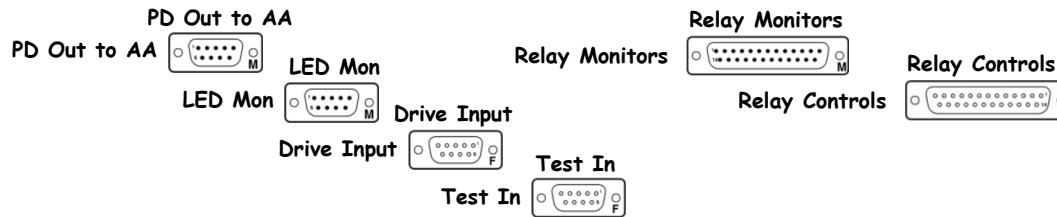

[S1001103](#)
Rear

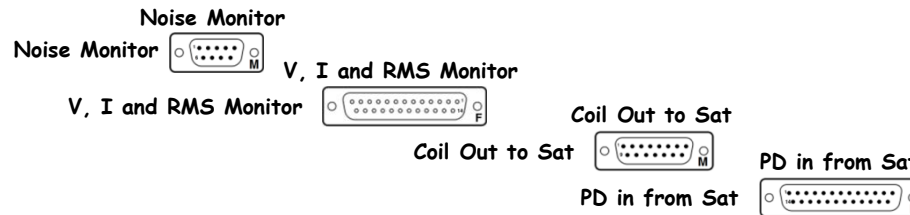

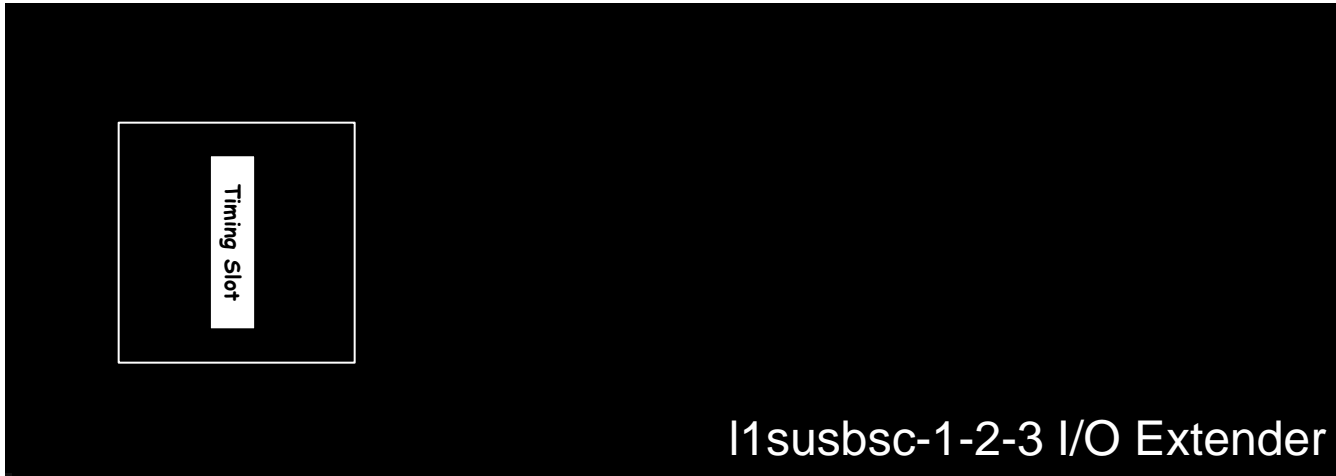

[D1001715](#)

Front

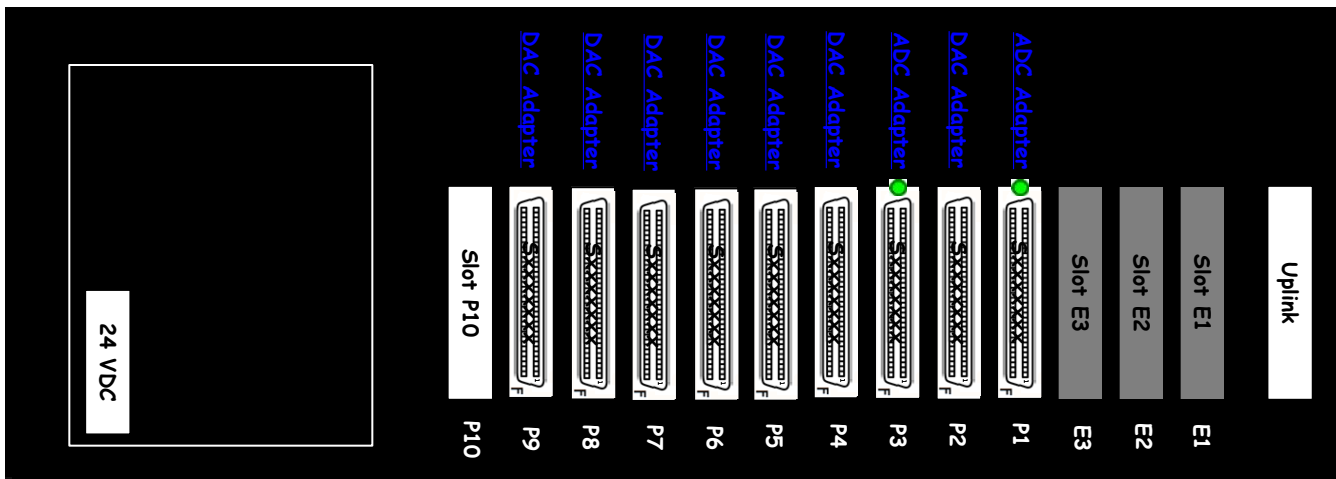

[S1001143](#)

Rear

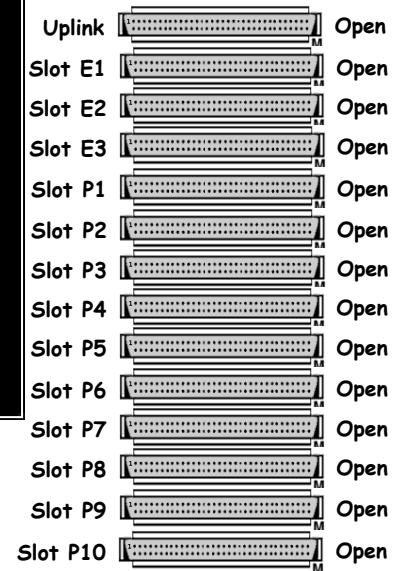

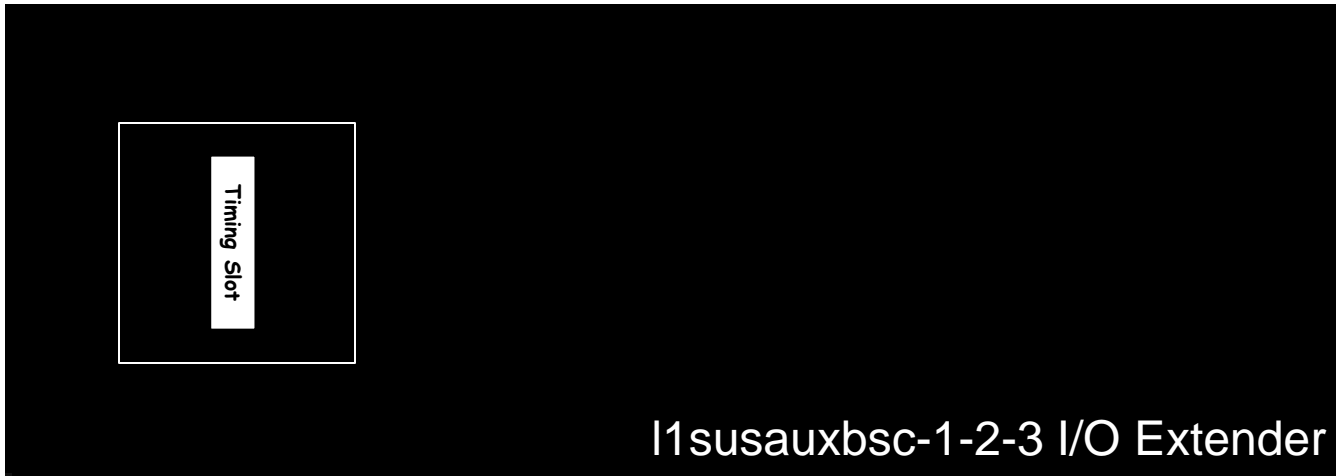

D1001715

Front

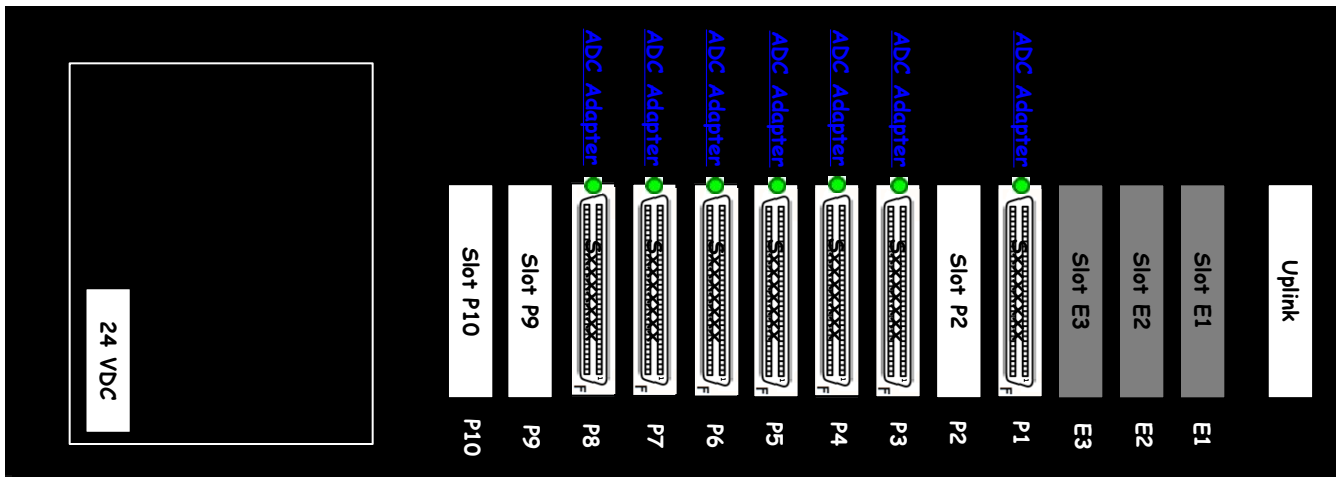

S1103888

Rear

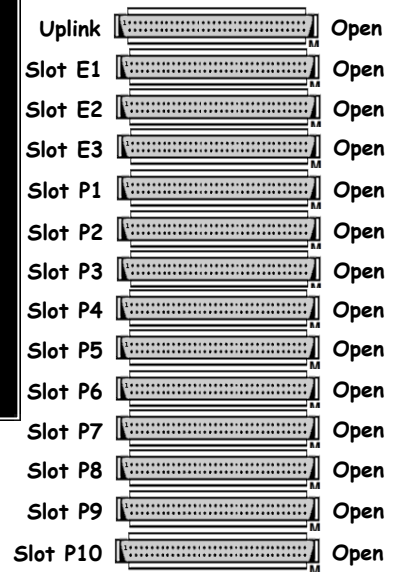

L1-SUS-C6 Details

L1-SUS-C7 Details

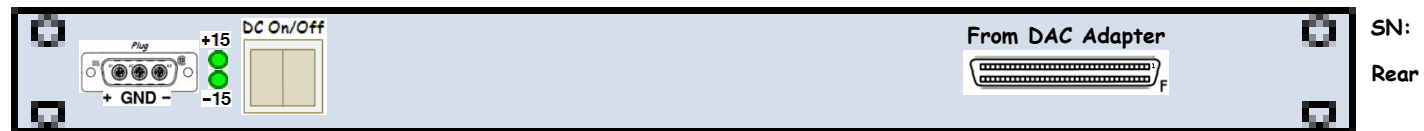
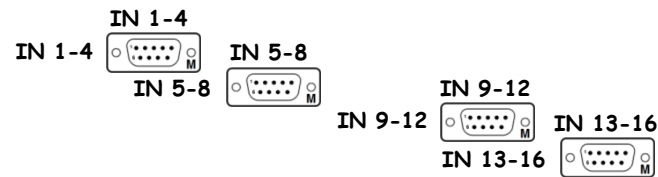
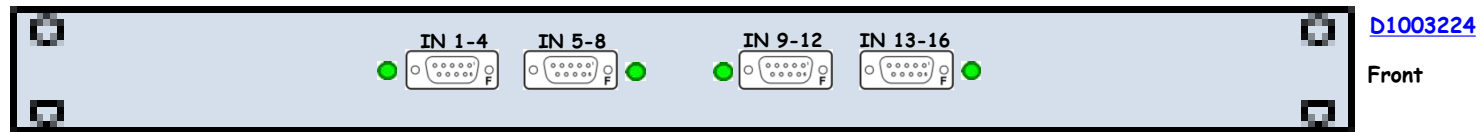

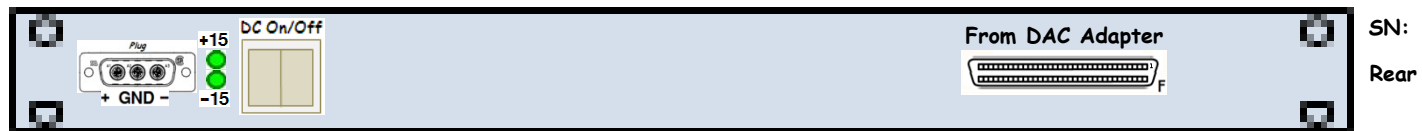
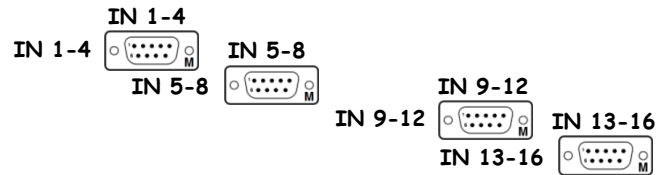
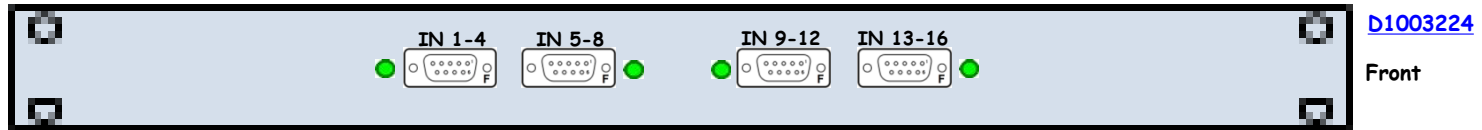

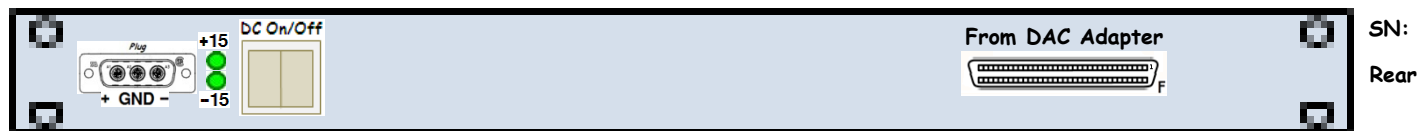
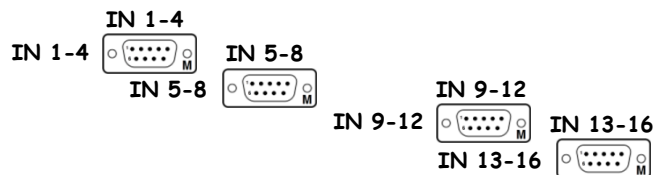
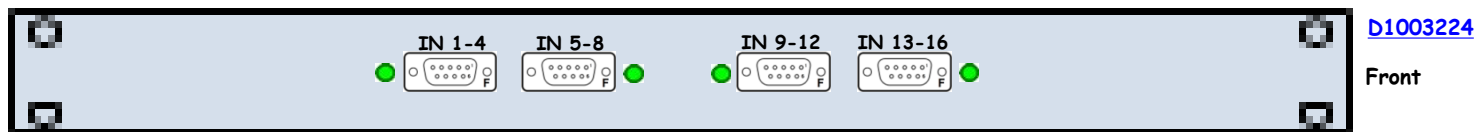

L1-SUS-C8 Details



D1001715

Front

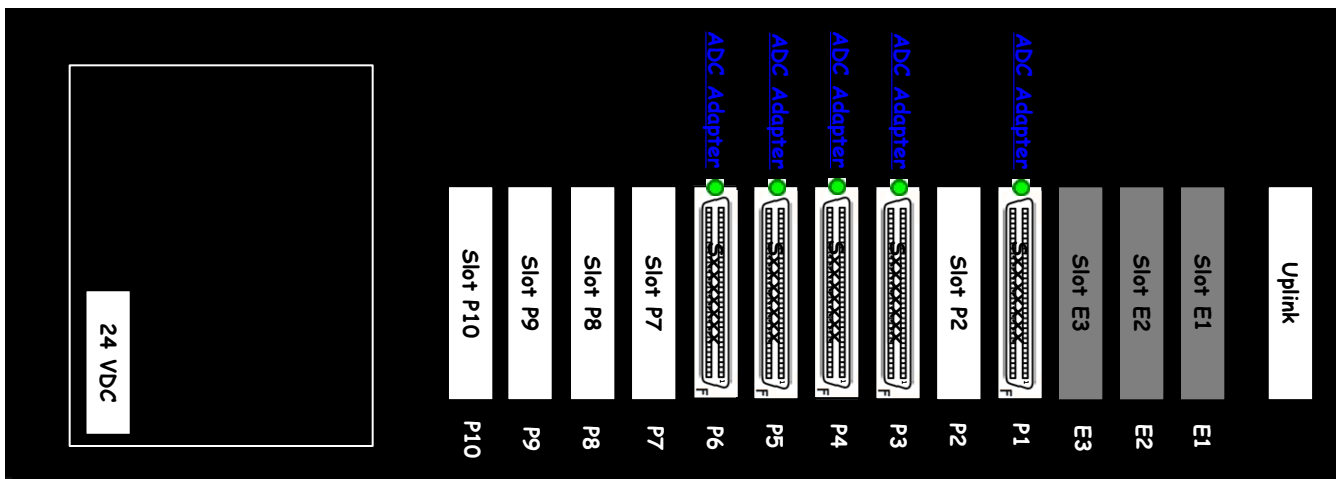

S1103889

Rear

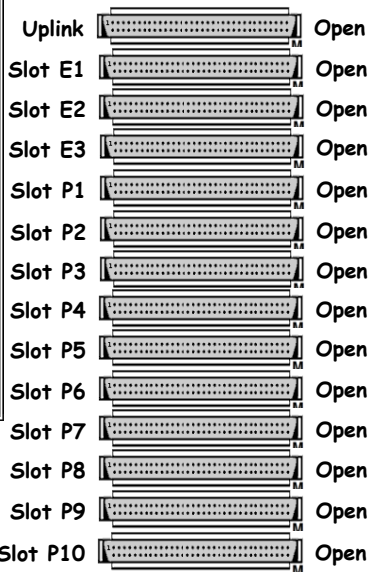

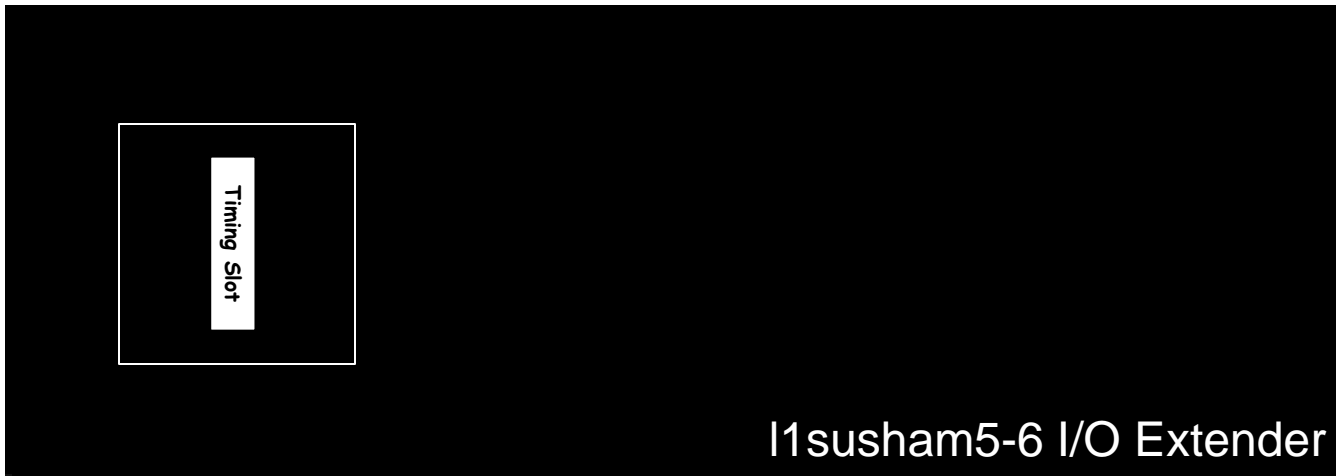

D1001715

Front

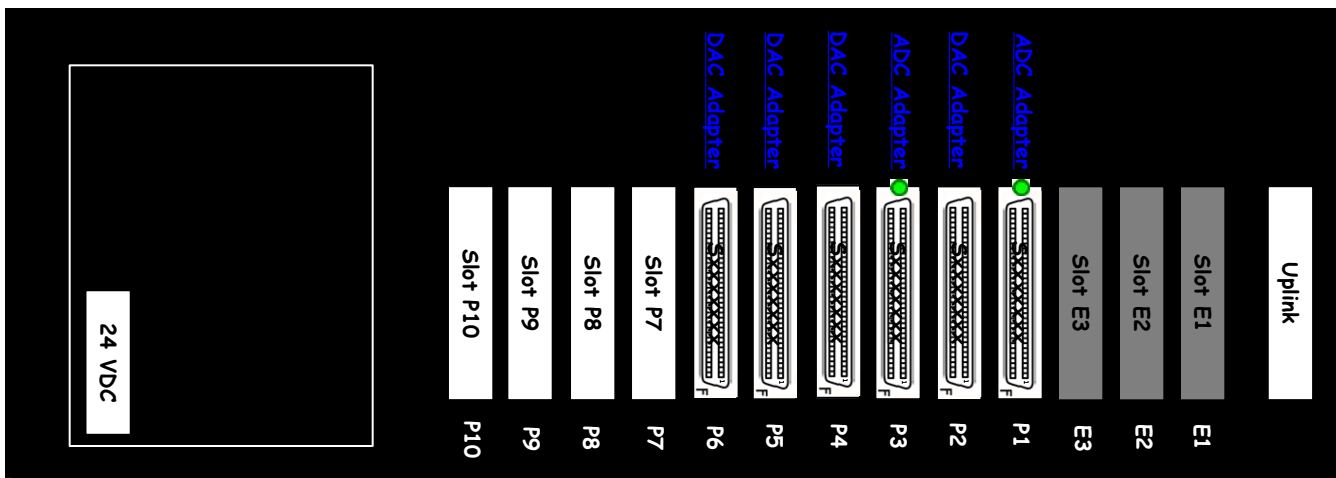

S1001142

Rear

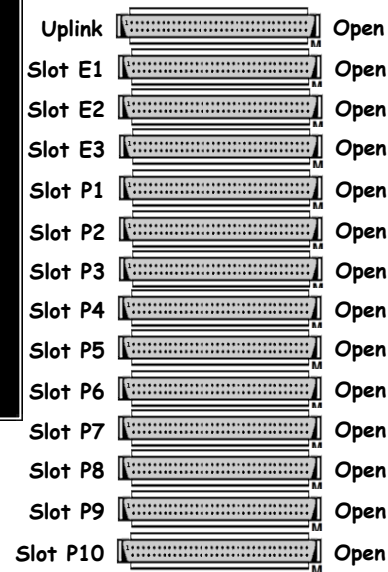

[<< LLO Map](#)[<< LLO Racks by AREA](#)[<< LLO CDS Components](#)

LVEA

17 Field Racks are in the LVEA, including the Vacuum Racks.
See [LIGO-D1003141](#)) at LLO and [LIGO-D1002704](#) at LHO.

LVEA Access Points

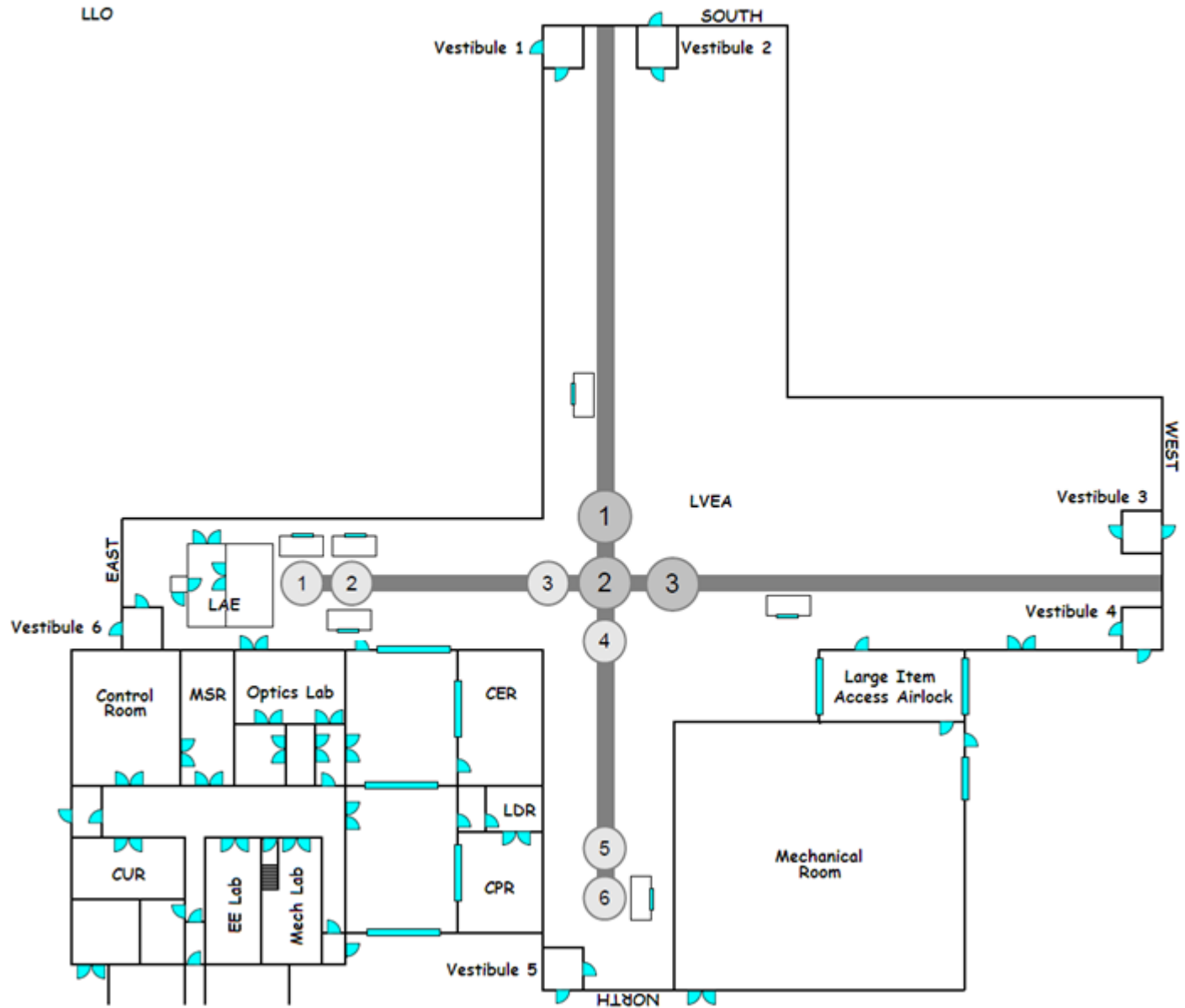

PSL / LDR Laser Hazard Zones

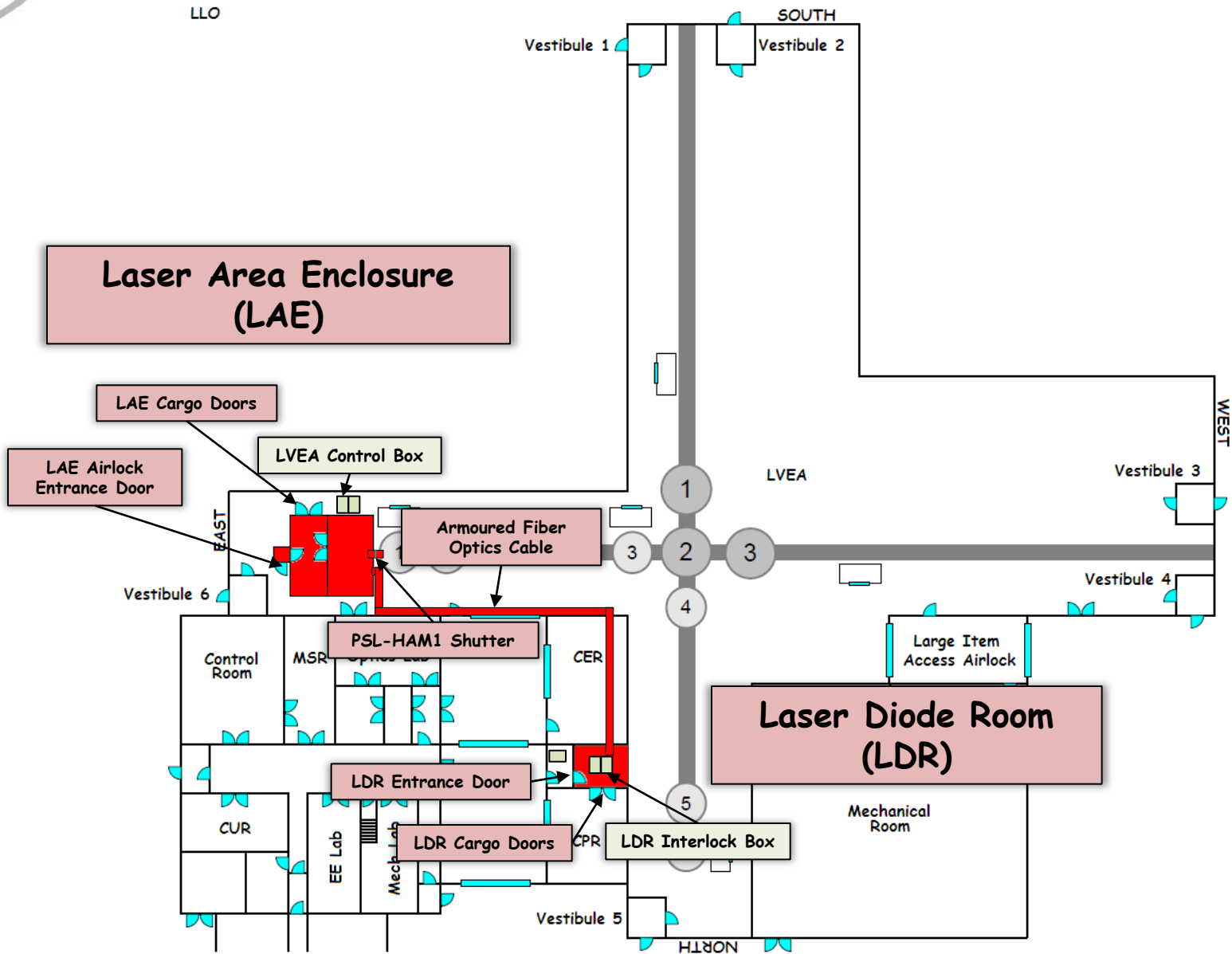

18 Field Racks are in the LVEA, including the Vacuum Racks.
See [LIGO-D1003141](#)) at LLO and [LIGO-D1002704](#) at LHO.

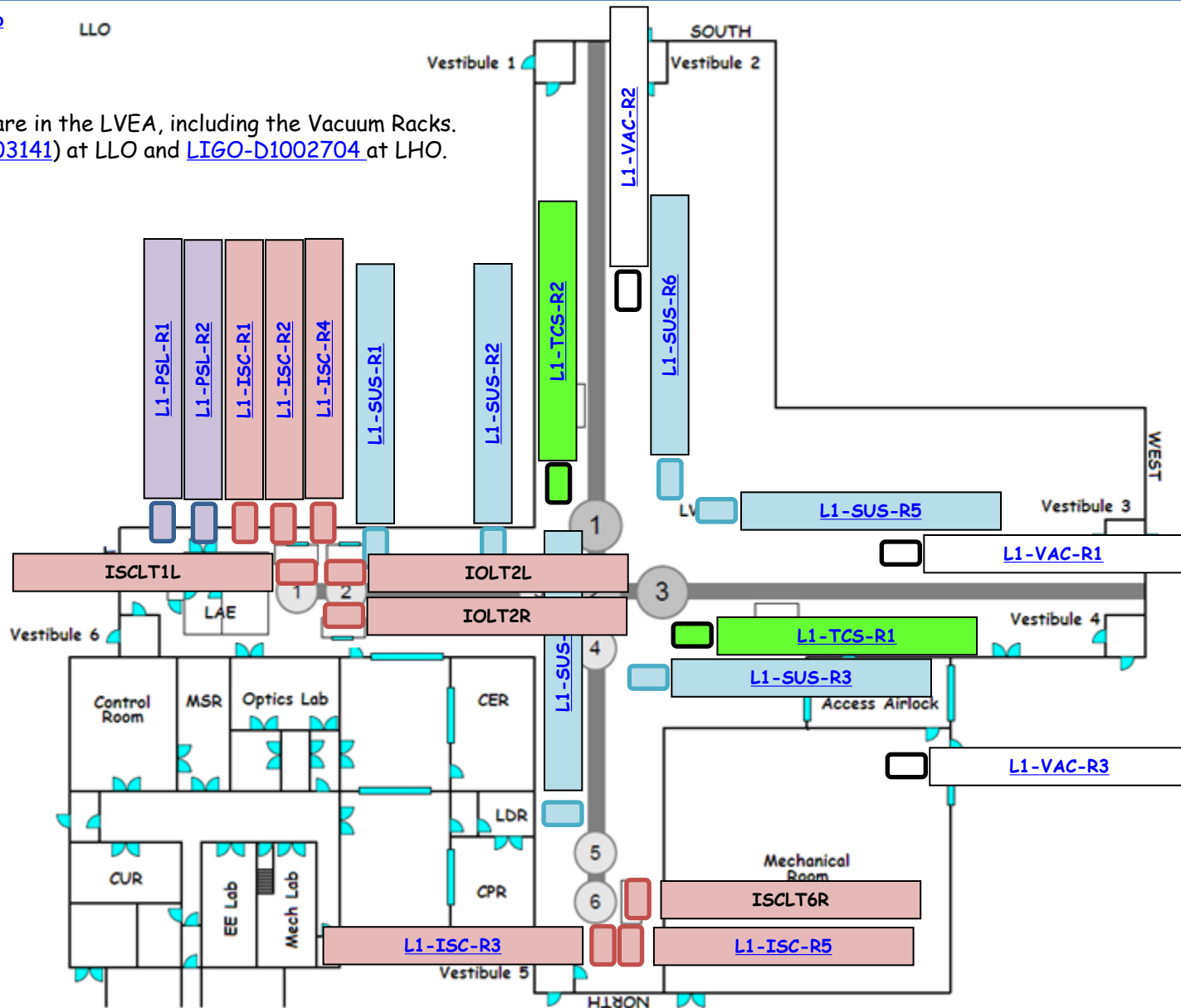

LVEA Racks

18 Field Racks are in the LVEA, including the Vacuum Racks.
See [LIGO-D1003141](#)) at LLO and [LIGO-D1002704](#) at LHO.

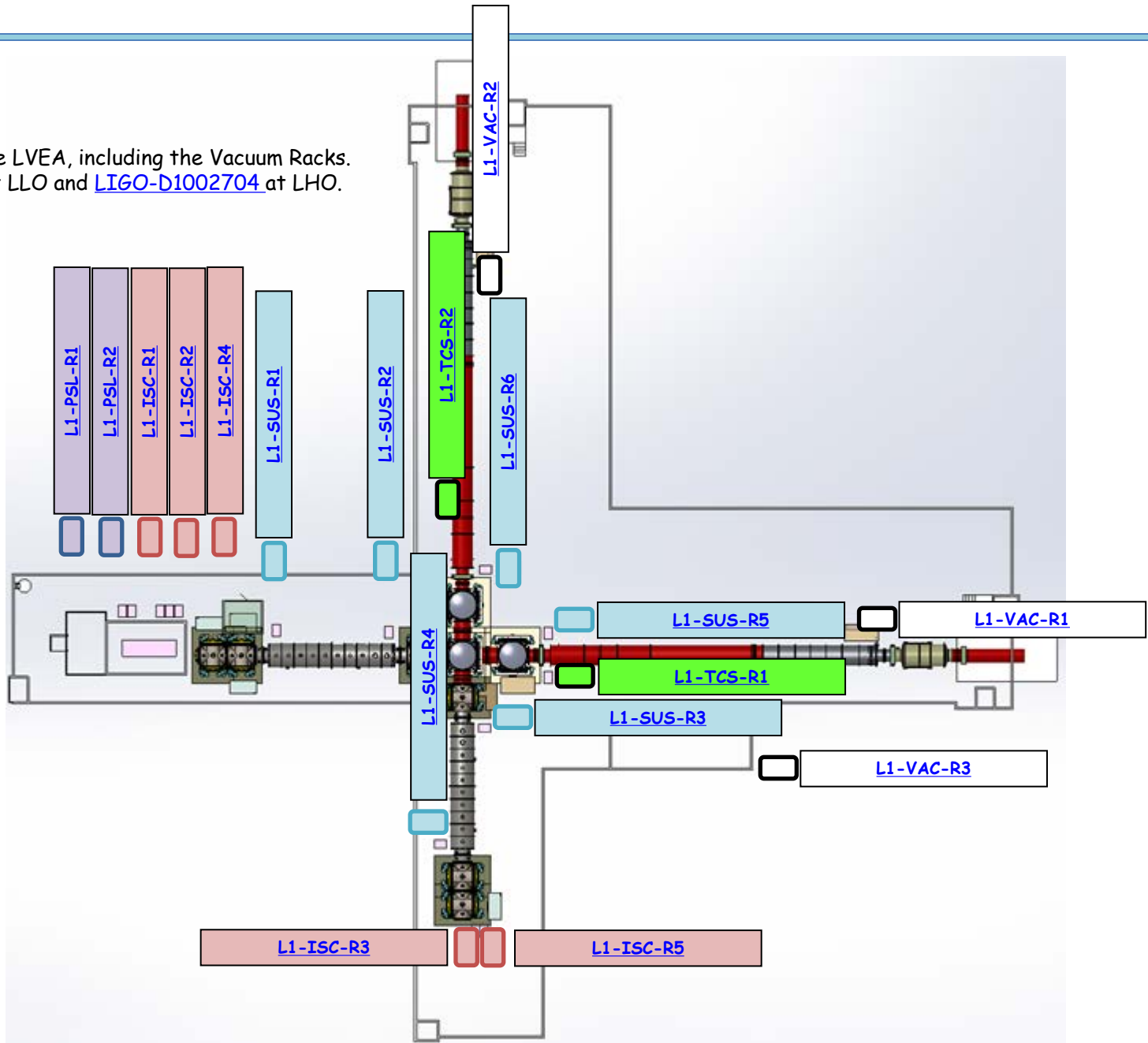

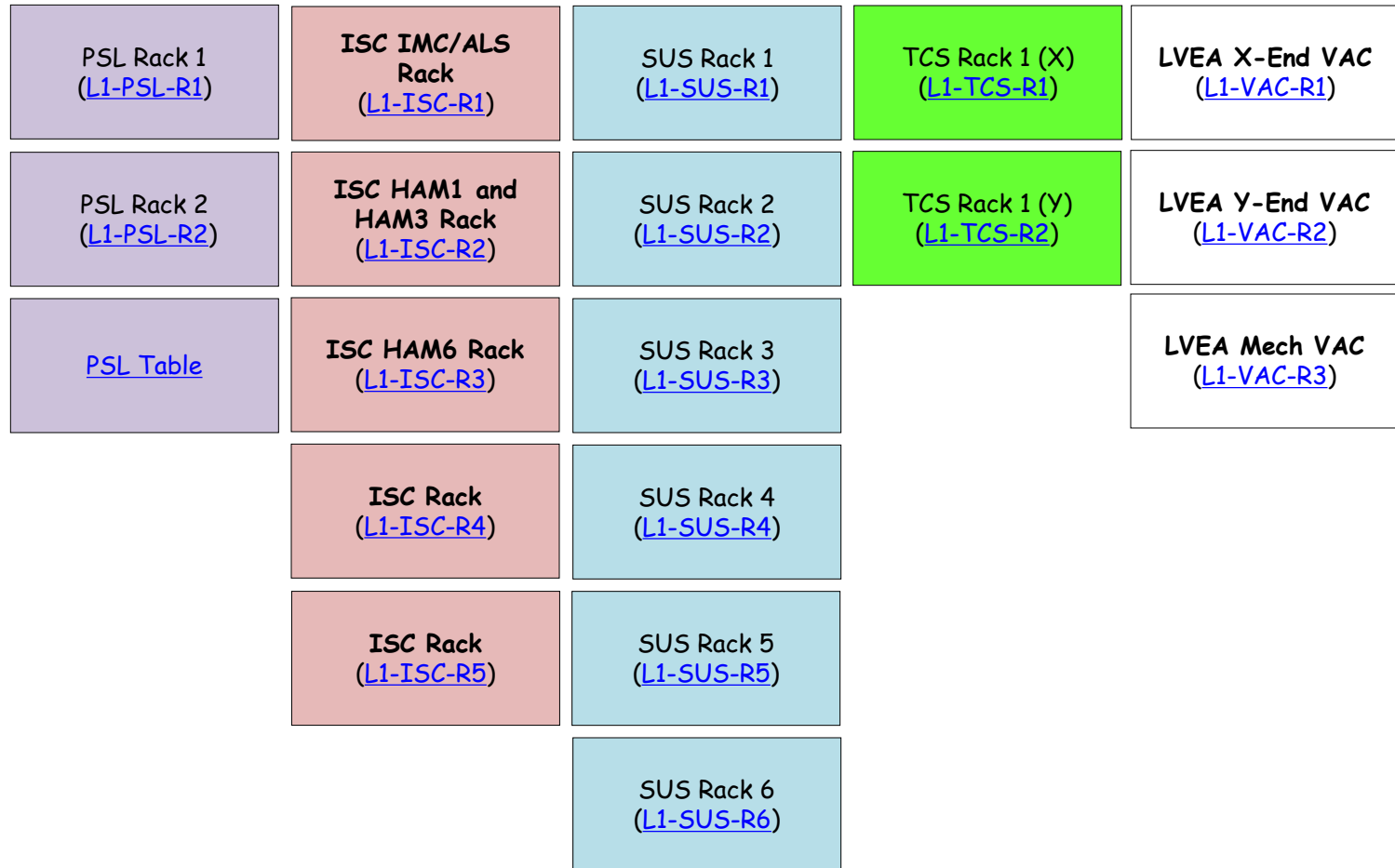

L1-PSL-R1

PSL Rack 1 Layout (LIGO-Dxxxxxxx)

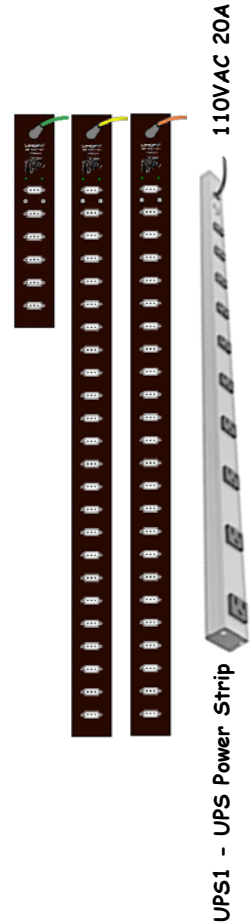
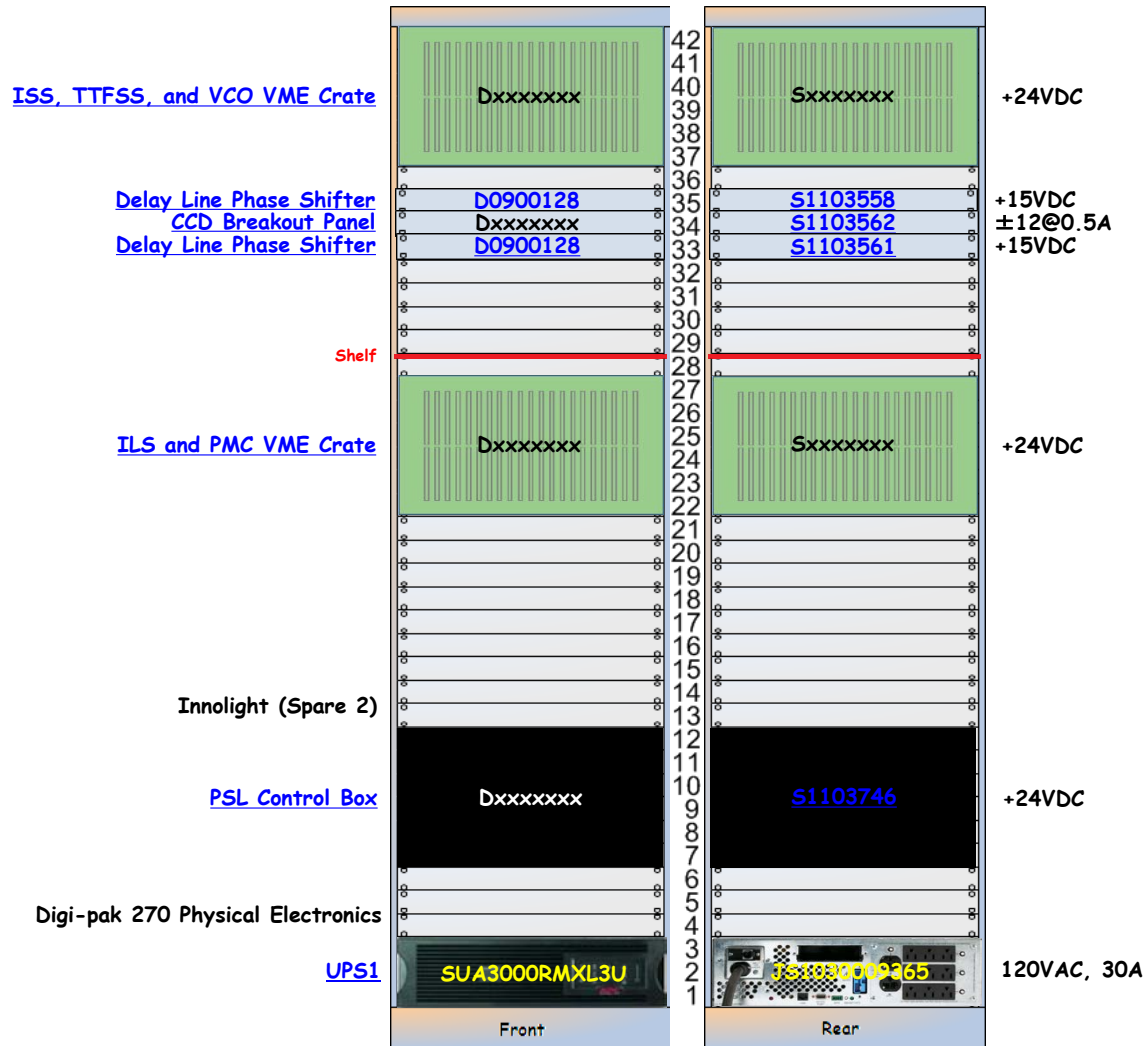

UPS1 - UPS Power Strip

ISS, TTFSS, and VCO VME Crate

<< [L1-PSL-R1](#)

ISS, TTFSS, and VCO VME Crate

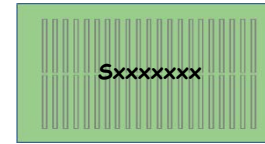
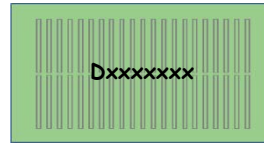

+24VDC

[S1103557](#)

[S1103554](#)

[S1103263](#)

[S1103555](#)

VME Crate

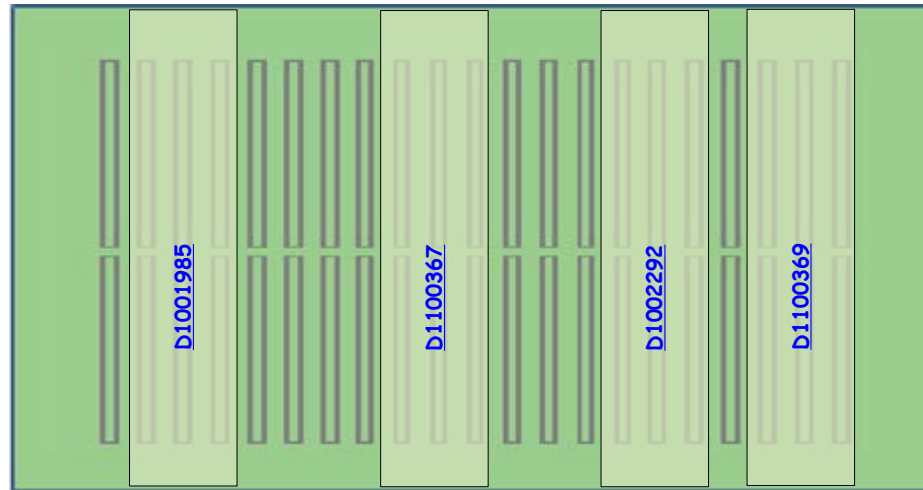

Intensity Stabilization
Servo Module

TTFSS Field Box

Monitoring Field Box Module

PSL VCO Field Box

[D1001985](#)

[D1100367](#)

[D1002292](#)

[D1100369](#)

D0900128 - S1103558



<< L1-PSL-R1

Delay Line Phase Shifter +15VDC

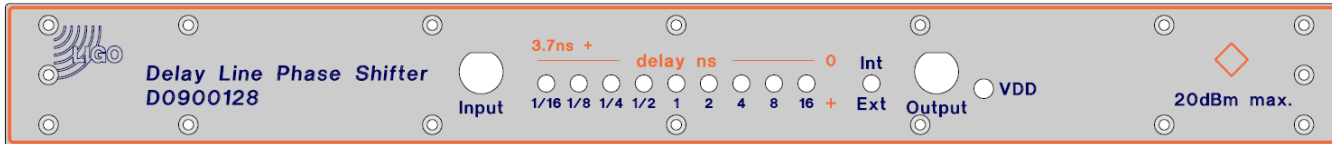

D0900128

Front

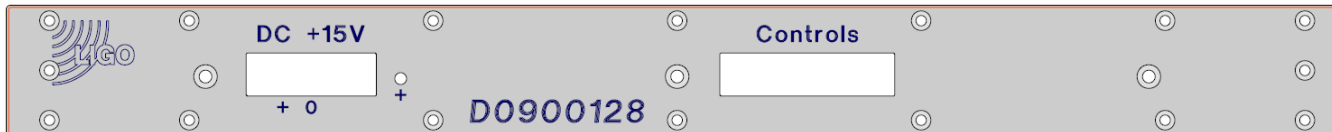
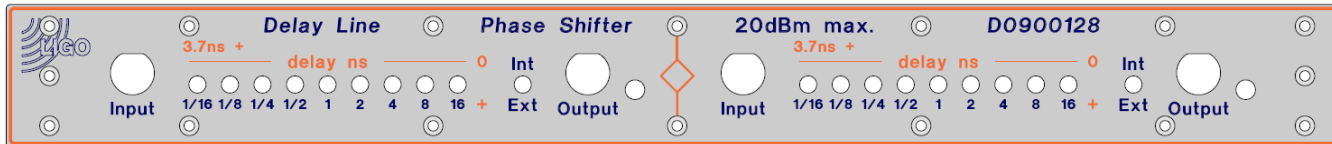

S1103558

Rear





Dxxxxxxx - S1103562

[<< L1-PSL-R1](#)

CCD Breakout Panel ±12@0.5A

<< L1-PSL-R1

Delay Line Phase Shifter +15VDC

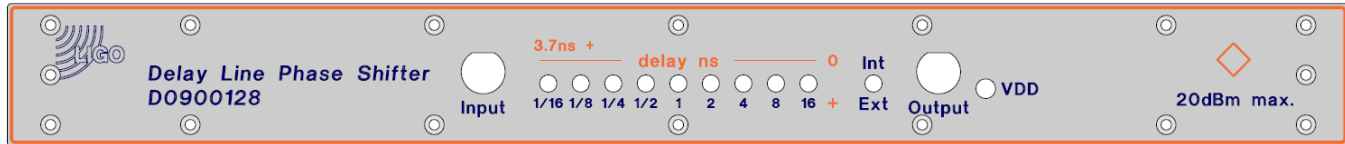

[D0900128](#)

Front

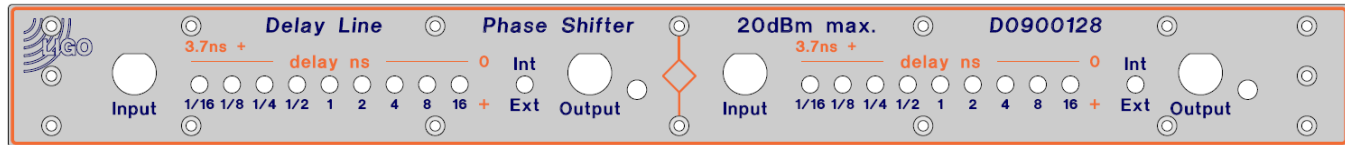

[S1103561](#)

Rear

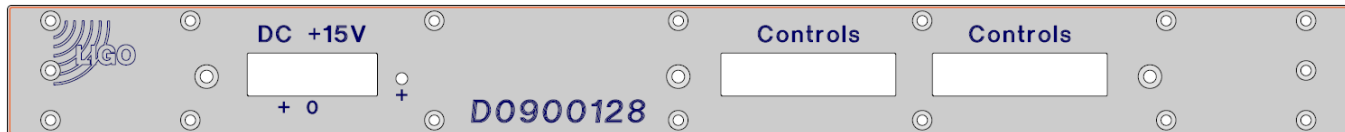
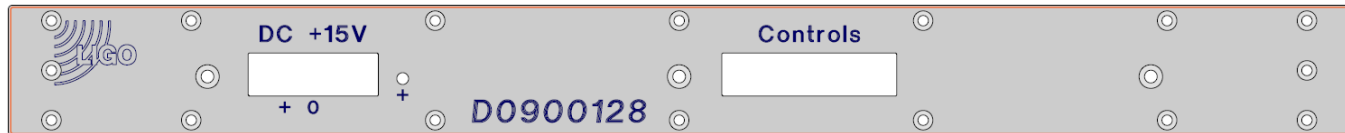

<< [L1-PSL-R1](#)

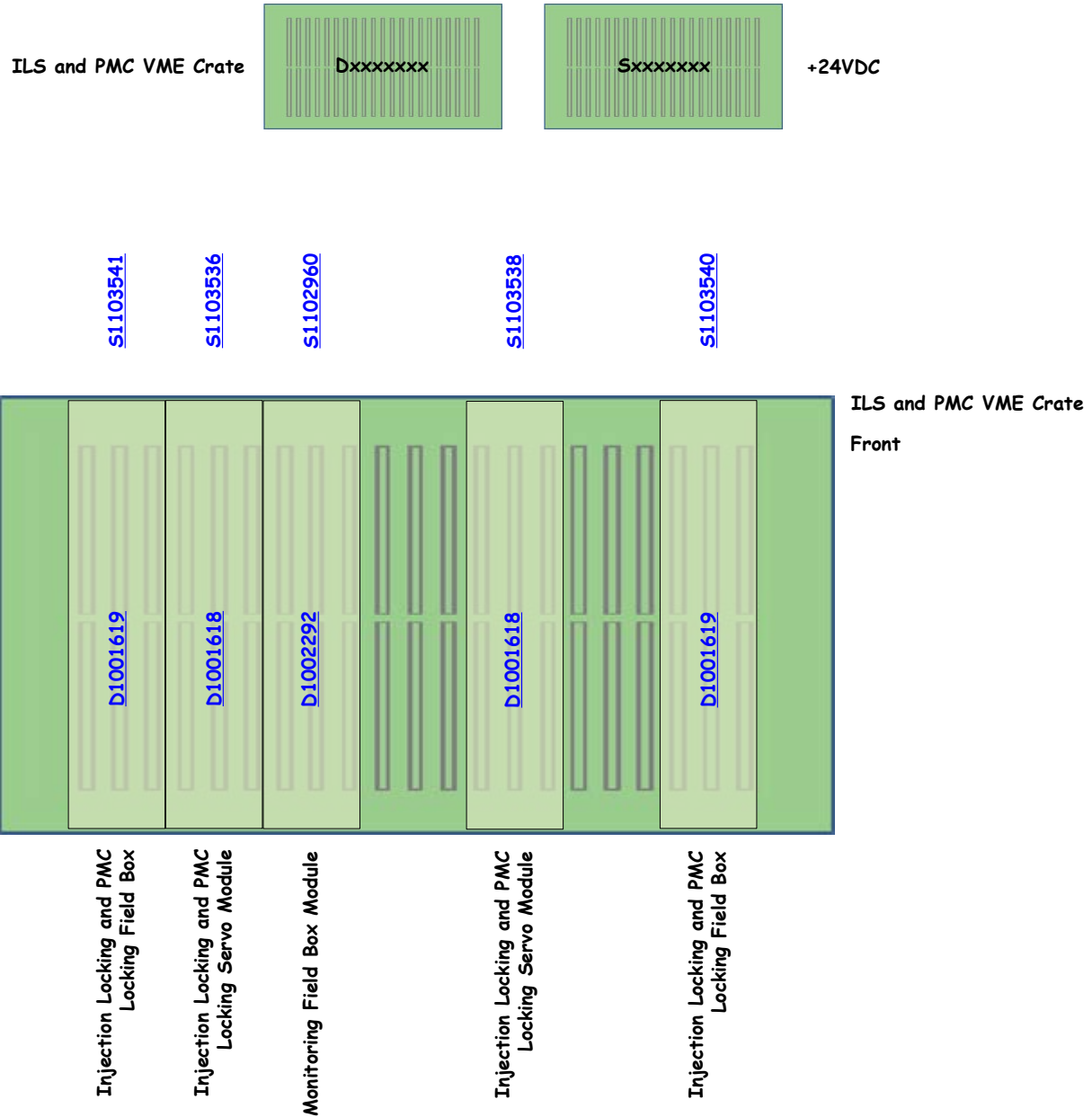

[<< L1-PSL-R1](#)

PSL Control Box

Dxxxxxxx

[S1103746](#)

+24VDC

PSL Control Box

[S1103746](#)

Front

<< L1-PSL-R1

UPS1

SUA3000RMXL3U

JS1030009365

120VAC, 30A



NEMA L5-30P

Camera Power Supplies ...

Panasonic 990 - LVEA1
Panasonic 990 - LVEA2

Agilent E4400B Signal Generator
IFR 2023A Signal Generator

Shelf

Tektronix TDS220

Stanford Research DS345

IFR 2023A Signal Generator

Shelf

Control

Shelf

Diagnostics Breadboard
(DBB) 0208 Crate



Diagnostics Breadboard (DBB) 0208

Shelf

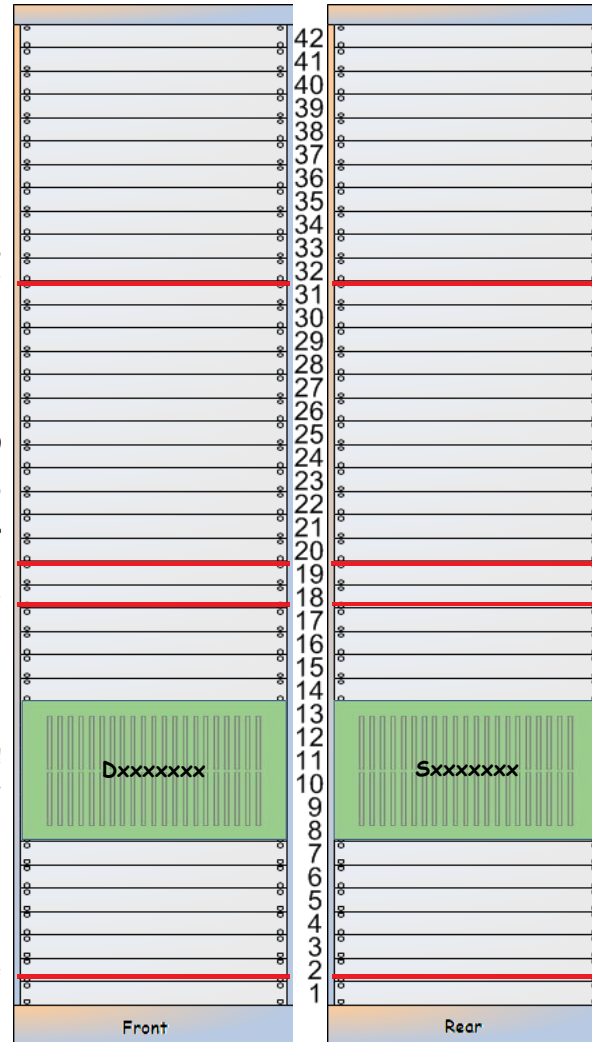

35.5MHz, 14.6dBm

80MHz, 32dBm

+ -19VDC, + -9VDC

CP5 Connector:
Pin 1: -19VDC
Pin 2: -9VDC
Pin 3: Ground
Pin 4: +9VDC
Pin 5: +19VDC

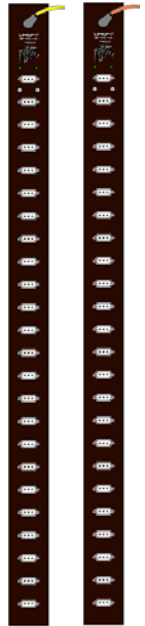

<< L1-PSL-R2

Diagnostics Breadboard
(DBB) VME Crate

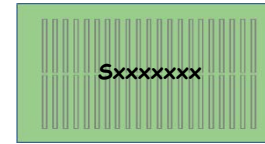
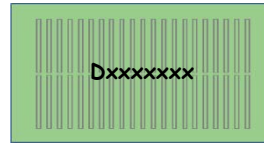

+24VDC

[S1103544](#)

[S1103546](#)

[S1103548](#)

[S1103550](#)

[S1103551](#)

Diagnostics Breadboard
(DBB) VME Crate

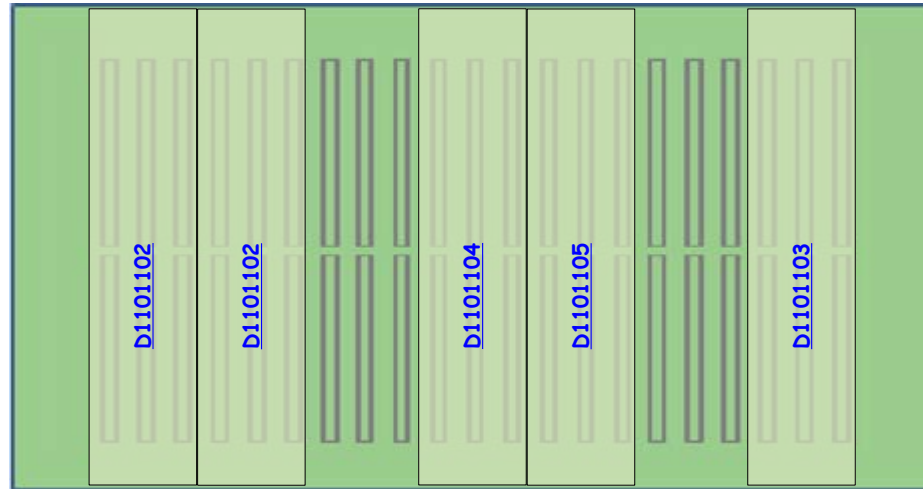

Diagnostics Breadboard
(DBB) VME Crate
Front

PSL Diagnostics Breadboard
High Voltage Module

PSL Diagnostics Breadboard
Field Box

PSL Diagnostics Breadboard
Demodulator Module

PSL Diagnostics Breadboard
Miscellaneous Module

PSL Diagnostics Breadboard
Calibration Module

ISC R1

LVEA IMC ALS Rack R1 Layout

41 U

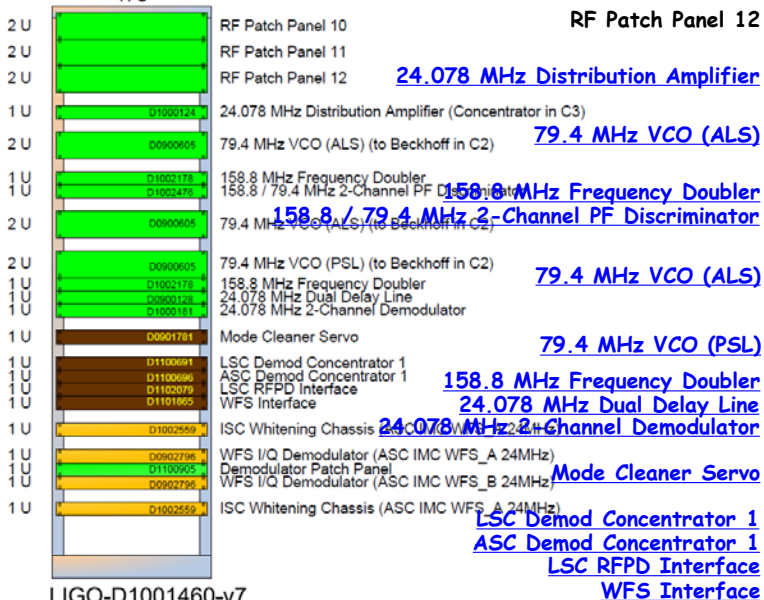

LIGO-D1001460-v7

- ISC Whitening Chassis (ASC IMC WFS A 24MHz)
- WFS I/Q Demodulator (ASC IMC WFS A 24MHz)
- Demodulator Patch Panel
- WFS I/Q Demodulator (ASC IMC WFS B 24MHz)
- ISC Whitening Chassis (ASC IMC WFS A 24MHz)

- RF Patch Panel 10
- RF Patch Panel 11
- RF Patch Panel 12

24.078 MHz Distribution Amplifier

79.4 MHz VCO (ALS)

158.8 MHz Frequency Doubler

158.8 / 79.4 MHz 2-Channel PF Discriminator

79.4 MHz VCO (ALS)

79.4 MHz VCO (PSL)

158.8 MHz Frequency Doubler

24.078 MHz Dual Delay Line

24.078 MHz 2-Channel Demodulator

Mode Cleaner Servo

LSC Demod Concentrator 1

LSC Demod Concentrator 1

LSC RFPD Interface

WFS Interface

- ISC Whitening Chassis (ASC IMC WFS A 24MHz)
- WFS I/Q Demodulator (ASC IMC WFS A 24MHz)
- Demodulator Patch Panel
- WFS I/Q Demodulator (ASC IMC WFS B 24MHz)
- ISC Whitening Chassis (ASC IMC WFS A 24MHz)

| | | | |
|----------|----|----------|----------------|
| Dxxxxxxx | 42 | Sxxxxxxx | No Power |
| Dxxxxxxx | 41 | Sxxxxxxx | No Power |
| Dxxxxxxx | 40 | Sxxxxxxx | No Power |
| Dxxxxxxx | 39 | Sxxxxxxx | No Power |
| Dxxxxxxx | 38 | Sxxxxxxx | No Power |
| Dxxxxxxx | 37 | Sxxxxxxx | No Power |
| D1000124 | 36 | Sxxxxxxx | ±17VDC, ±24VDC |
| D1000124 | 35 | Sxxxxxxx | ±17VDC, ±24VDC |
| D0900605 | 34 | Sxxxxxxx | ±17VDC, ±24VDC |
| D0900605 | 33 | Sxxxxxxx | ±17VDC, ±24VDC |
| D1002178 | 32 | Sxxxxxxx | ±17VDC, ±24VDC |
| D1002476 | 31 | Sxxxxxxx | ±17VDC, ±24VDC |
| D1002476 | 30 | Sxxxxxxx | ±17VDC, ±24VDC |
| D0900605 | 29 | Sxxxxxxx | ±17VDC, ±24VDC |
| D0900605 | 28 | Sxxxxxxx | ±17VDC, ±24VDC |
| D0900605 | 27 | Sxxxxxxx | ±17VDC, ±24VDC |
| D0900605 | 26 | Sxxxxxxx | ±17VDC, ±24VDC |
| D0900605 | 25 | Sxxxxxxx | ±17VDC, ±24VDC |
| D0900605 | 24 | Sxxxxxxx | ±17VDC, ±24VDC |
| D1002178 | 23 | Sxxxxxxx | ±17VDC, ±24VDC |
| D0900128 | 22 | Sxxxxxxx | ±17VDC, ±24VDC |
| D1000181 | 21 | Sxxxxxxx | +15VDC |
| D1000181 | 20 | Sxxxxxxx | ±17VDC, ±24VDC |
| D0901781 | 19 | Sxxxxxxx | ±17VDC, ±24VDC |
| D0901781 | 18 | Sxxxxxxx | ±17VDC, ±24VDC |
| D1100691 | 17 | Sxxxxxxx | ±18VDC |
| D1100696 | 16 | Sxxxxxxx | No Power |
| D1102079 | 15 | Sxxxxxxx | ±18VDC |
| D1101865 | 14 | Sxxxxxxx | ±15VDC |
| D1101865 | 13 | Sxxxxxxx | ±15VDC |
| D1002559 | 12 | Sxxxxxxx | ±15VDC |
| D1002559 | 11 | Sxxxxxxx | ±15VDC |
| D0902796 | 10 | Sxxxxxxx | ±15VDC |
| D1100905 | 9 | Sxxxxxxx | No Power |
| D0902796 | 8 | Sxxxxxxx | ±15VDC |
| D0902796 | 7 | Sxxxxxxx | ±15VDC |
| D1002559 | 6 | Sxxxxxxx | ±15VDC |
| D1002559 | 5 | Sxxxxxxx | ±15VDC |
| D1002559 | 4 | Sxxxxxxx | ±15VDC |
| D1002559 | 3 | Sxxxxxxx | ±15VDC |
| D1002559 | 2 | Sxxxxxxx | ±15VDC |
| D1002559 | 1 | Sxxxxxxx | ±15VDC |

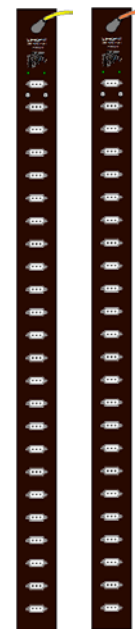

ISC R2

Serving ISC HAM 1 and HAM 3

41 U

| | |
|-----|---|
| 2 U | RF Patch Panel 13 |
| 2 U | RF Patch Panel 14 |
| 1 U | D1000124 45 MHz Distribution Amplifier |
| 1 U | D1000124 9.099 / 8.684 MHz Distribution Amplifier |
| 1 U | D0900128 9.099 / 8.684 MHz Dual Delay Line |
| 1 U | D1000151 9.099 / 8.684 MHz 2-Channel Demodulator |
| 1 U | D1002559 ISC Whitening Chassis (LSC POPAIR A 9&45, LSC REFLAIR A 45) |
| 1 U | D0902796 LSC I/Q Demodulator (LSC POPAIR A 9&45, LSC REFLAIR A 45) |
| 1 U | D1100956 LSC Demodulator Patch Panel |
| 1 U | D0902796 LSC I/Q Demodulator (LSC POPAIR B 18&90, LSC REFLAIR B 27&135) |
| 1 U | D1002559 ISC Whitening Chassis (LSC POPAIR B 18&90, LSC REFLAIR B 27&135) |
| 1 U | D0902796 LSC I/Q Demodulator (LSC POP, LSC REFL) |
| 1 U | D1100956 LSC Demodulator Patch Panel |
| 1 U | D1002559 ISC Whitening Chassis (LSC POP, LSC REFL) |
| 1 U | D1002559 ISC Whitening Chassis (ASC REFLAIR A 9MHz) |
| 1 U | D0902796 WFS I/Q Demodulator (ASC REFLAIR A 9MHz) |
| 1 U | D1100905 WFS Demodulator Patch Panel |
| 1 U | D0902796 WFS I/Q Demodulator (ASC REFLAIR A 45MHz) |
| 1 U | D1002559 ISC Whitening Chassis (ASC REFLAIR A 45MHz) |
| 1 U | D1002559 ISC Whitening Chassis (ASC REFLAIR B 9MHz) |
| 1 U | D0902796 WFS I/Q Demodulator (ASC REFLAIR B 9MHz) |
| 1 U | D1100905 Demodulator Patch Panel |
| 1 U | D0902796 WFS I/Q Demodulator (ASC REFLAIR B 45MHz) |
| 1 U | D1002559 ISC Whitening Chassis (ASC REFLAIR B 45MHz) |
| 1 U | D0902796 WFS I/Q Demodulator (Spare chain for air to vac leapfrog) |
| 1 U | D1100905 Demodulator Patch Panel |
| 1 U | D1002559 ISC Whitening Chassis (Spare chain for air to vac leapfrog) |

LIGO-D1001425-v6

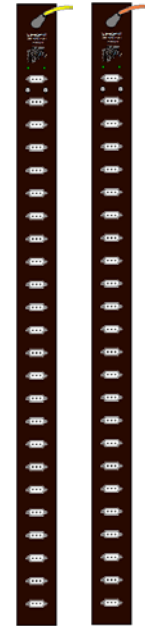
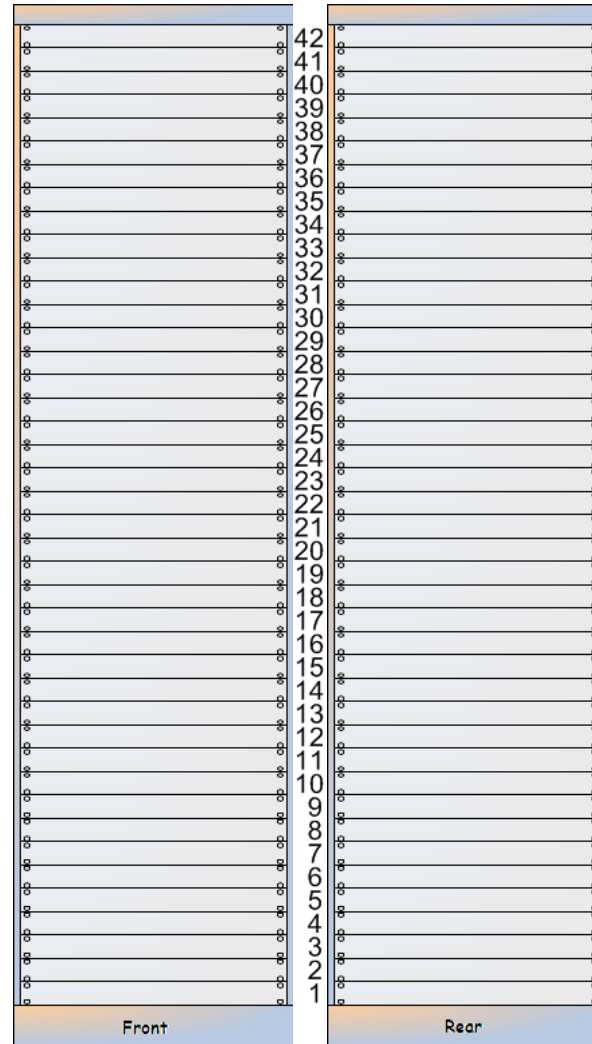

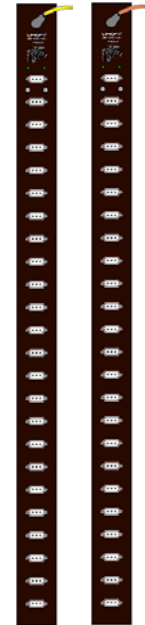
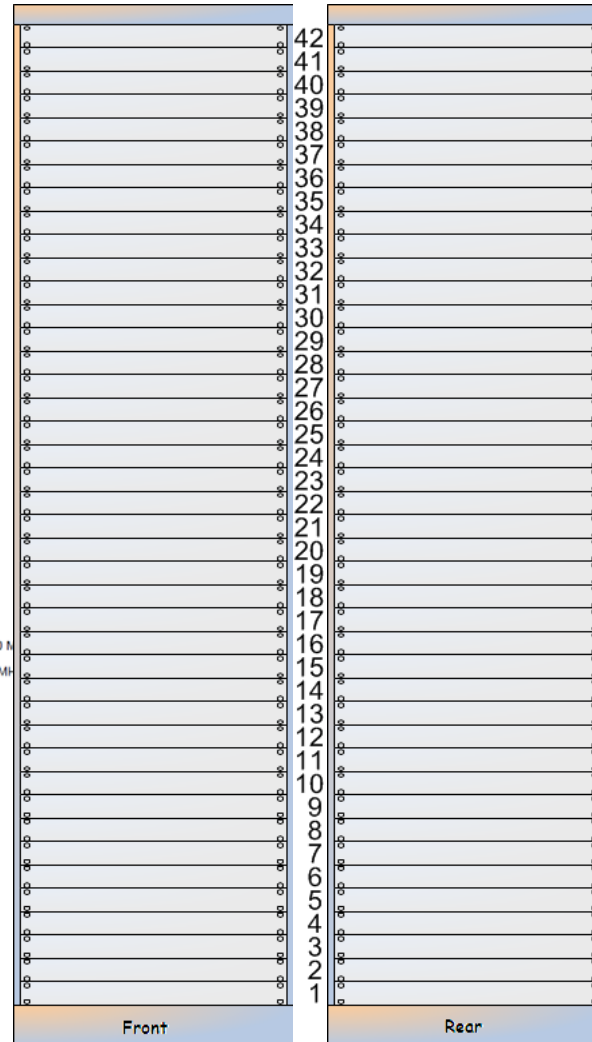
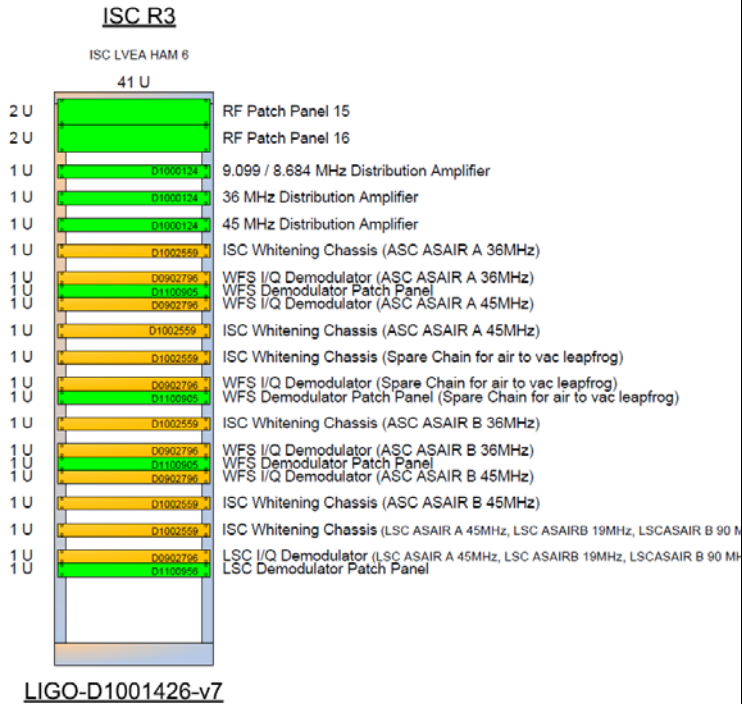

ISC R4

Serves HAM 1 and HAM 3

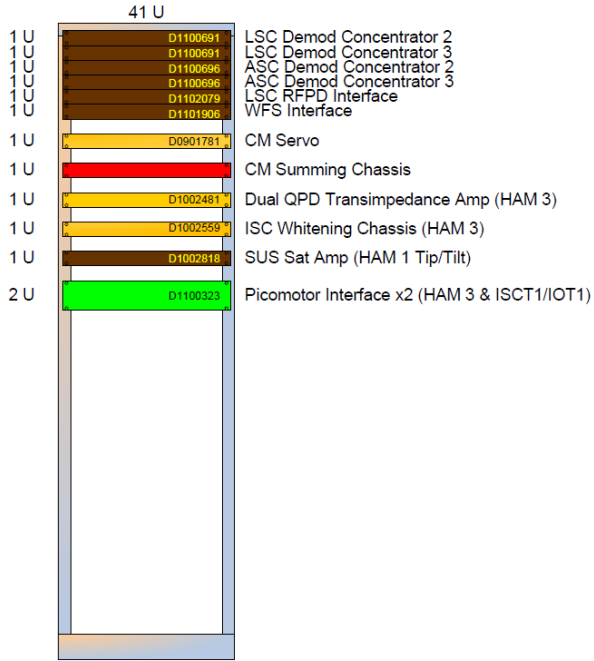

LIGO-D1101904-v4

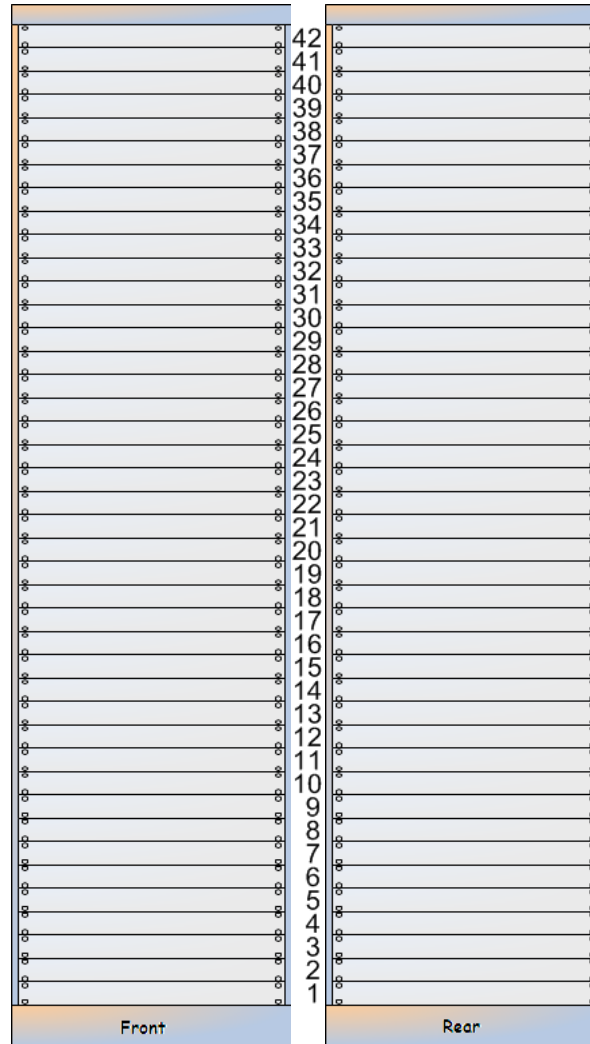

ISC R5

Serves LVEA HAM 6

41 U

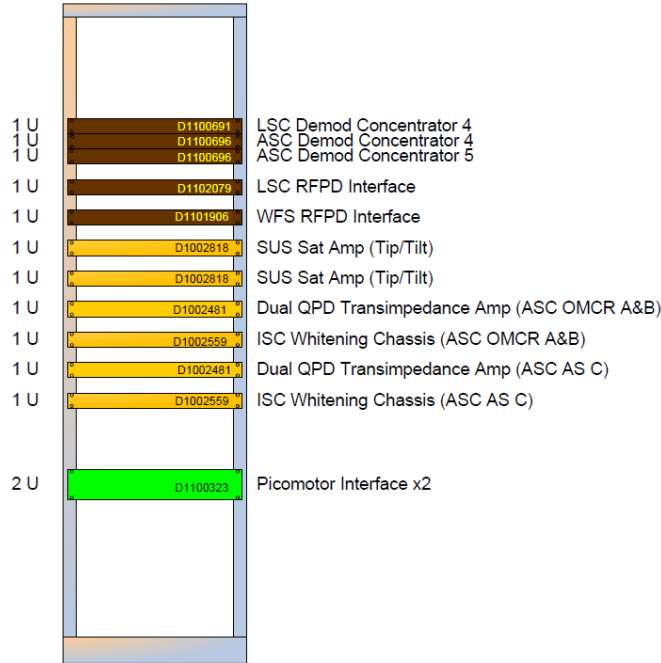

LIGO-D1200196-v3

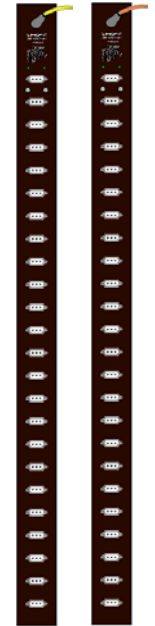
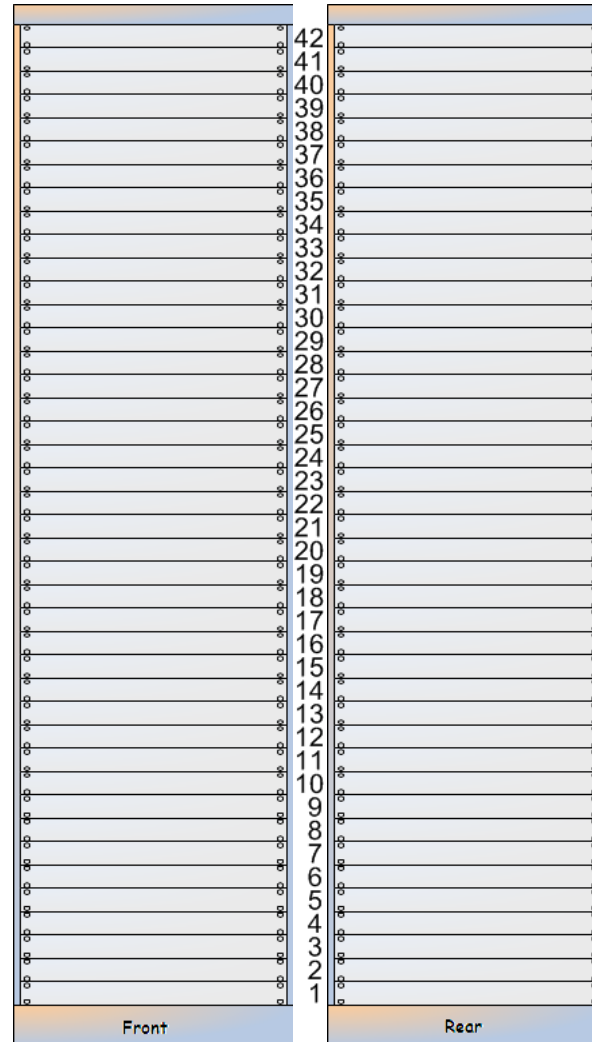

L1-ISC-R1 Details

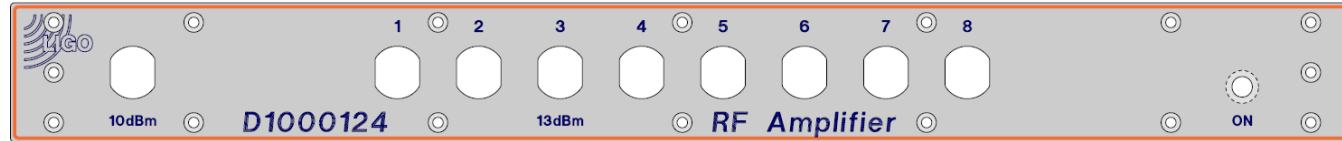

[D1000124](#)

Front

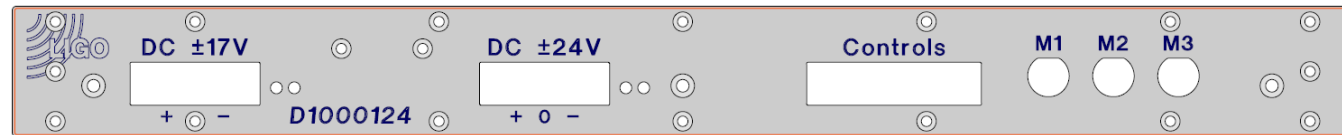

[S1001232](#)

Rear

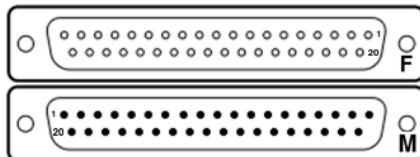

<< L1-ISC-R1

79.4 MHz VCO (ALS)

D0900605

Sxxxxxxx

±17VDC, ±24VDC

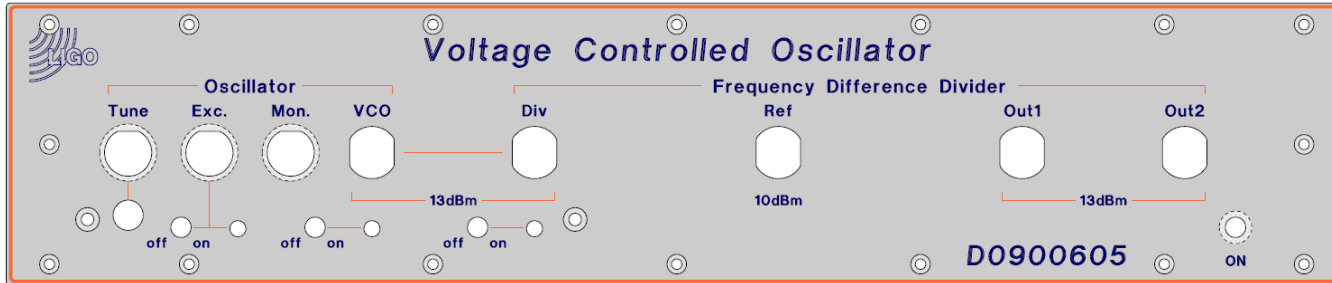

D0900605

Front

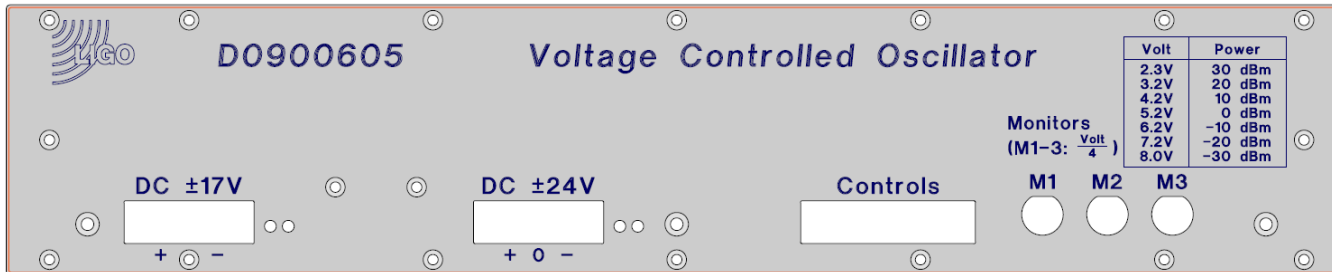

S1001232

Rear

D1002178 - Sxxxxxxx



<< L1-ISC-R1

24.078 MHz Distribution Amplifier

D1002178

Sxxxxxxx

±17VDC, ±24VDC

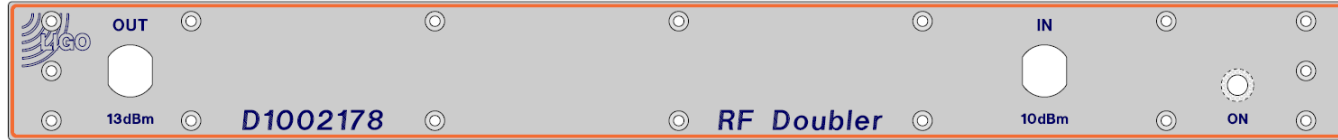

D1002178

Front

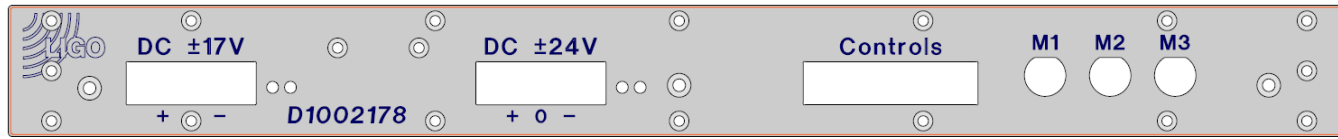

S1001232

Rear

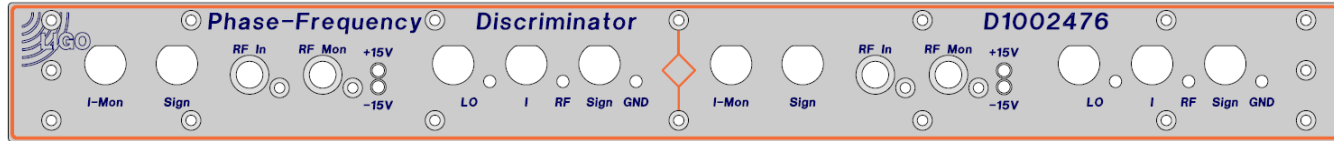

[D1002476](#)

Front

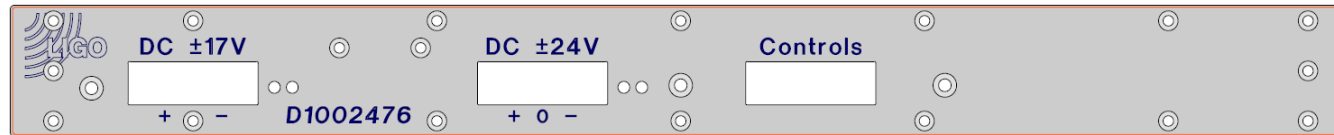

[S1001232](#)

Rear

<< L1-ISC-R1

79.4 MHz VCO (ALS)

D0900605

Sxxxxxxx

±17VDC, ±24VDC

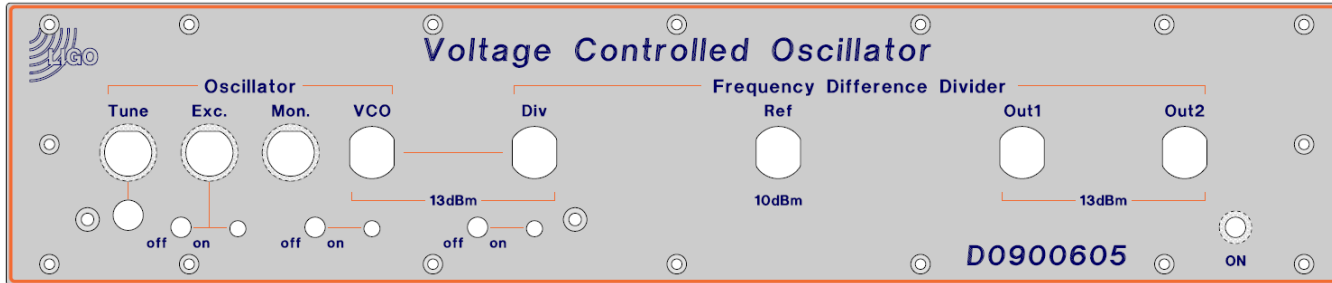

D0900605

Front

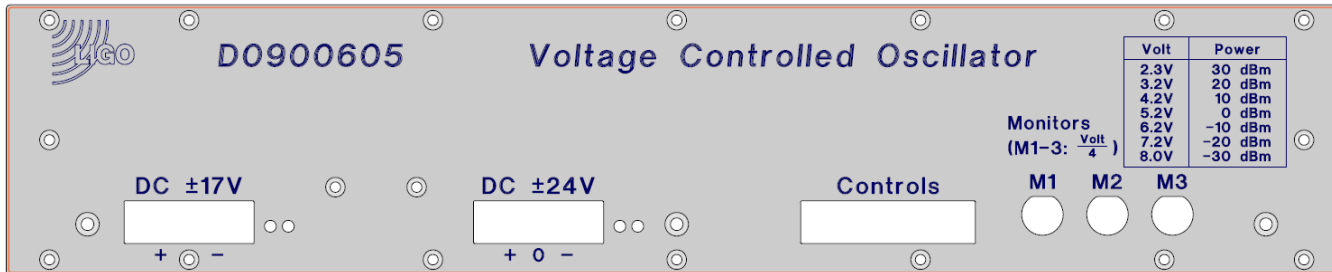

S1001232

Rear

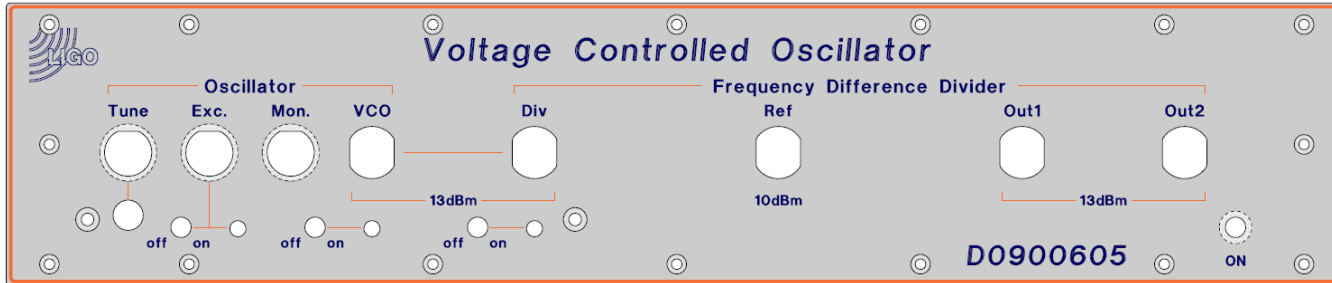

D0900605

Front

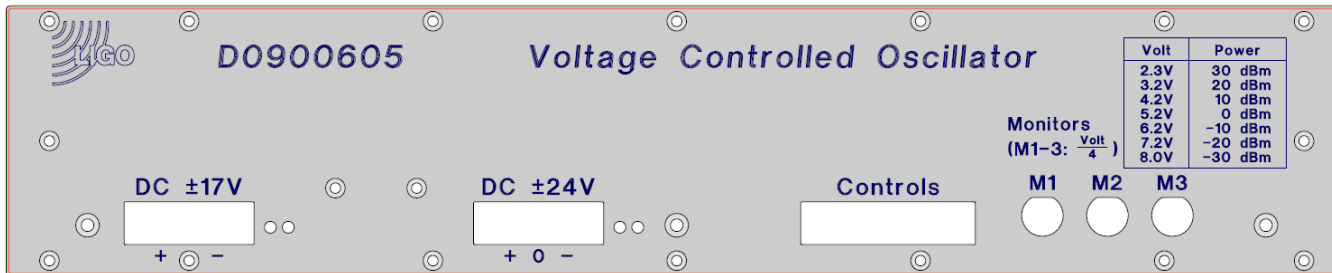

S1001232

Rear

<< [L1-ISC-R1](#)

24.078 MHz Distribution Amplifier

[D1002178](#)

[Sxxxxxxx](#)

$\pm 17\text{VDC}$, $\pm 24\text{VDC}$

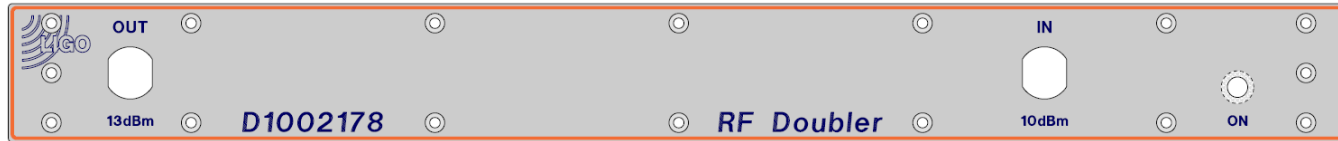

[D1002178](#)

Front

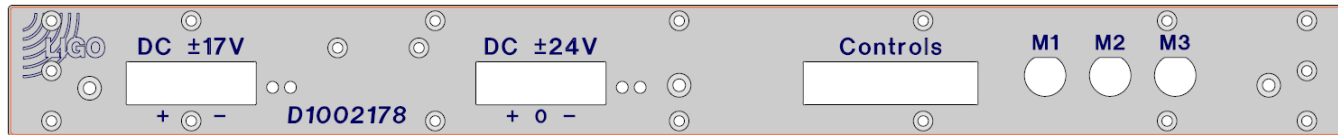

[S1001232](#)

Rear

<< L1-ISC-R1

24.078 MHz Dual Delay Line +15VDC

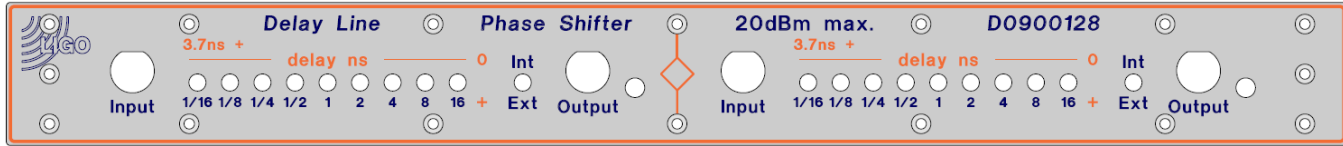

D0900128

Front



Sxxxxxxx

Rear

<< L1-ISC-R1

24.078 MHz 2-Channel Demodulator ±17VDC, ±24VDC

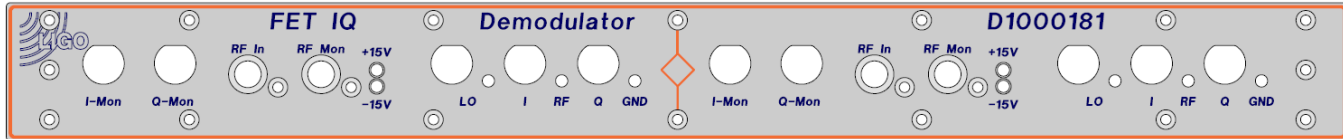

D1000181

Front

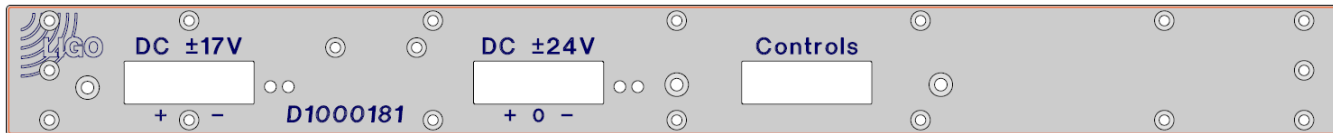

Sxxxxxxx

Rear

D0901781 - Sxxxxxxx



<< L1-ISC-R1

Mode Cleaner Servo ±17VDC, ±24VDC

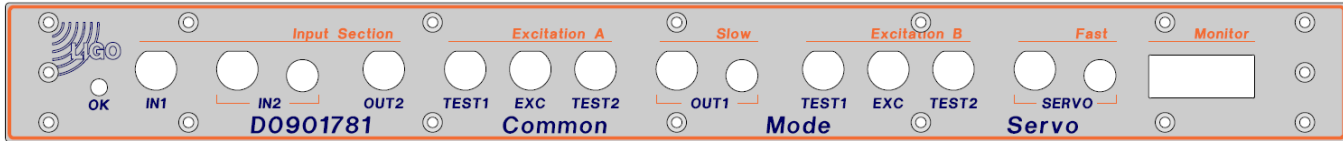

D0901781

Front

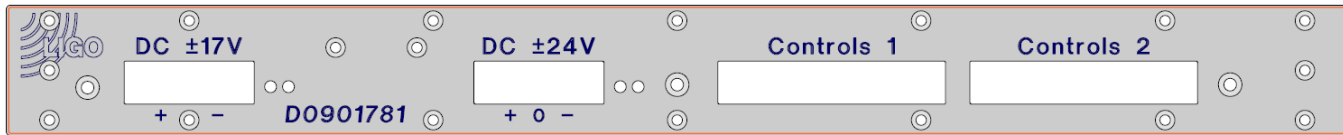

Sxxxxxxx

Rear

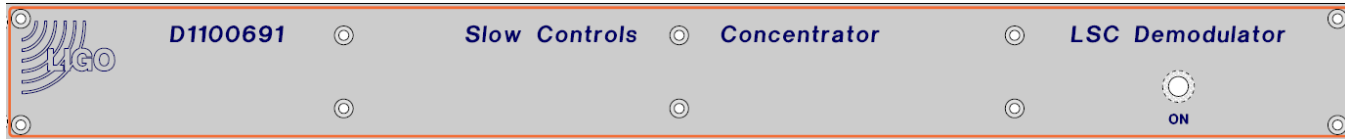

[D1100691](#)

Front

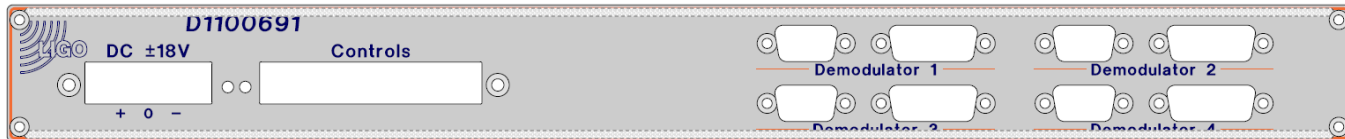

Sxxxxxxx

Rear

D1100696 - Sxxxxxxx



<< L1-ISC-R1

ASC Demod Concentrator 1 ±18VDC

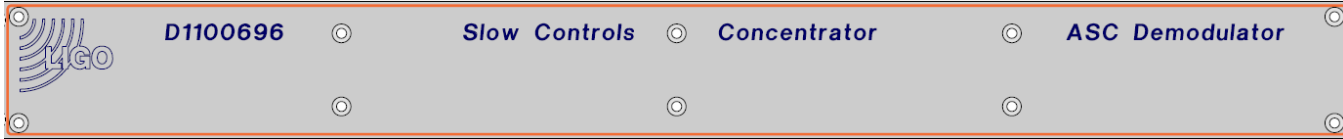

D1100696

Front

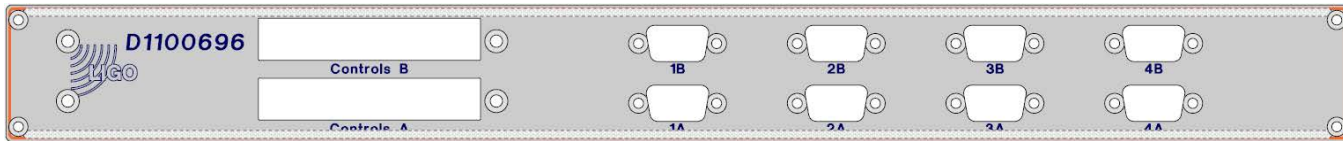

Sxxxxxxx

Rear

<< L1-ISC-R1

LSC RFPD Interface D1102079 Sxxxxxxx ±18VDC

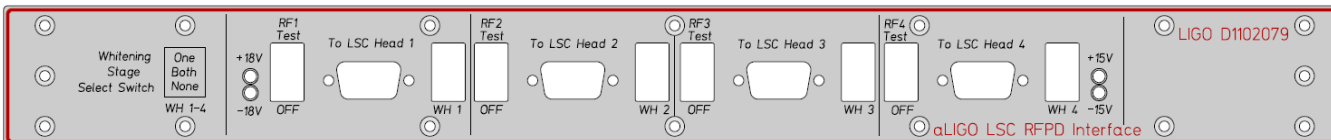

D1102079

Front

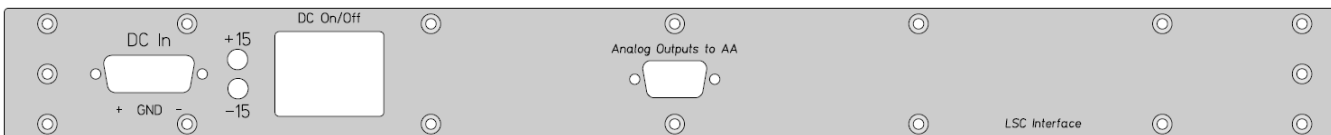

Sxxxxxxx

Rear

D1101905

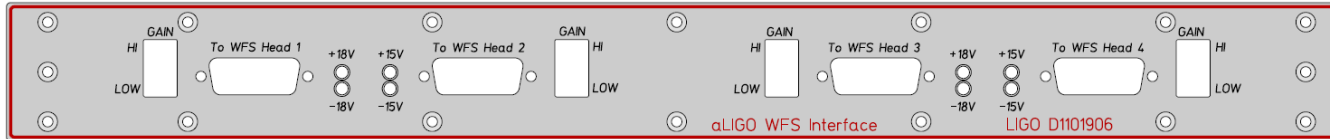

D1101865

Front

D1101908

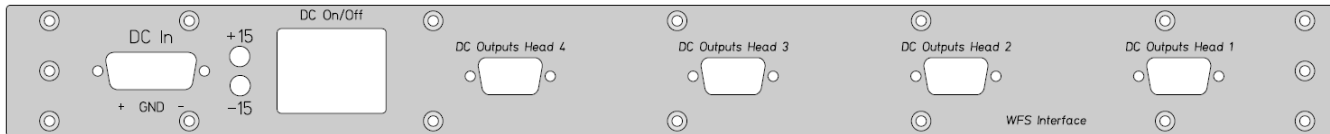

Sxxxxxxx

Rear

<< [L1-ISC-R1](#) ISC Whitening Chassis (ASC IMC WFS_A 24MHz) D1002559 Sxxxxxxx ±15VDC

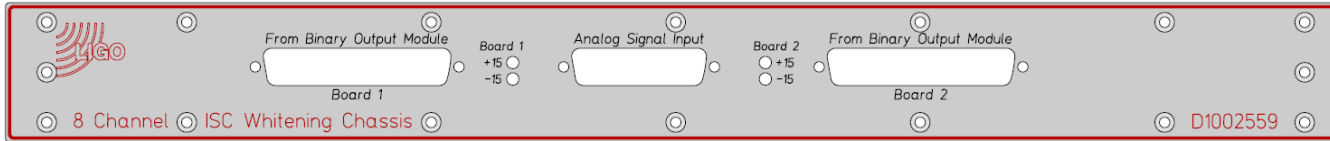

[D1002559](#)

Front

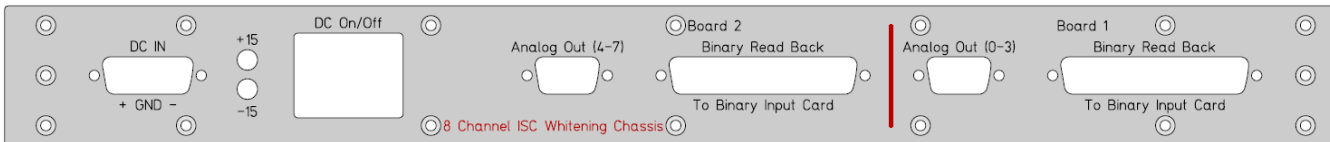

Sxxxxxxx

Rear

<< L1-ISC-R1 ISC Whitening Chassis (ASC IMC WFS_A 24MHz) D0902796 Sxxxxxxx ±15VDC

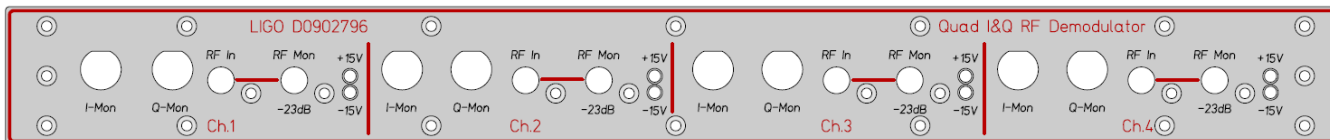

D0902796

Front

D1002032

LSC

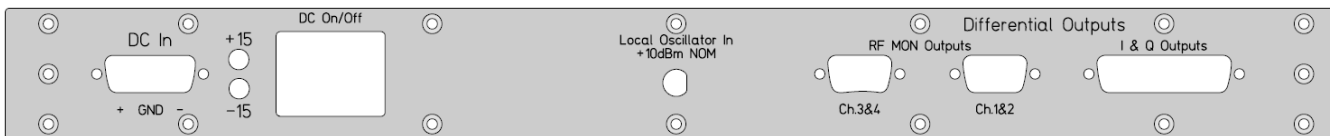

Sxxxxxxx

Rear

D1002031

WFS

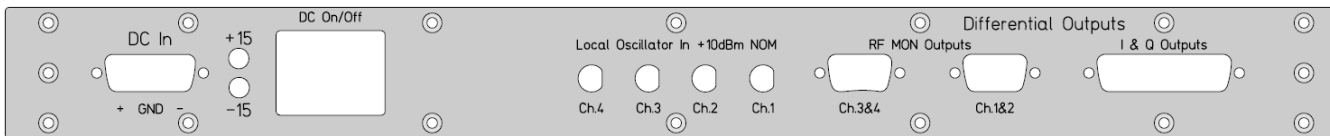

<< [L1-ISC-R1](#)

Demodulator Patch Panel

[D1100905](#)

[Sxxxxxxx](#)

No Power

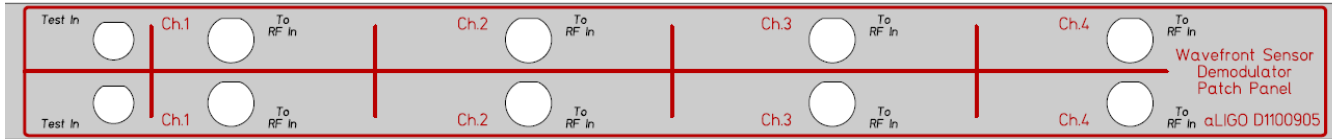

[D1100905](#)

Front

[Sxxxxxxx](#)

<< [L1-ISC-R1](#) ISC Whitening Chassis (ASC IMC WFS_B 24MHz) D0902796 Sxxxxxxx ±15VDC

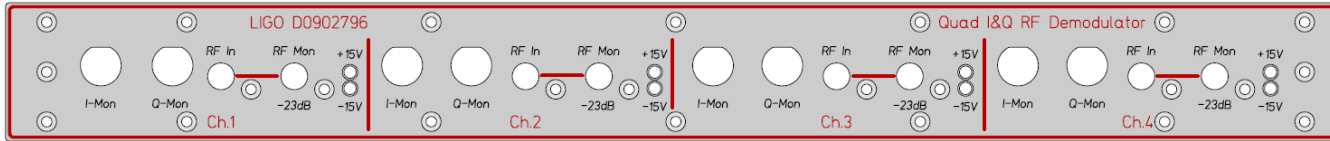

[D0902796](#)

Front

[D1002032](#)

LSC

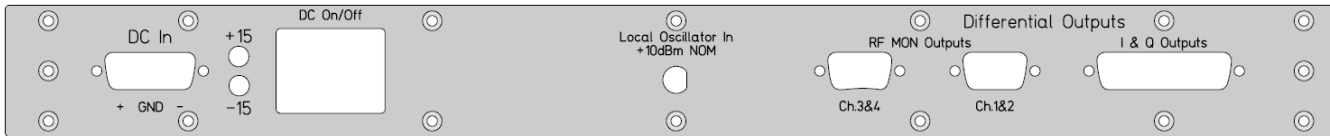

Sxxxxxxx

Rear

[D1002031](#)

WFS

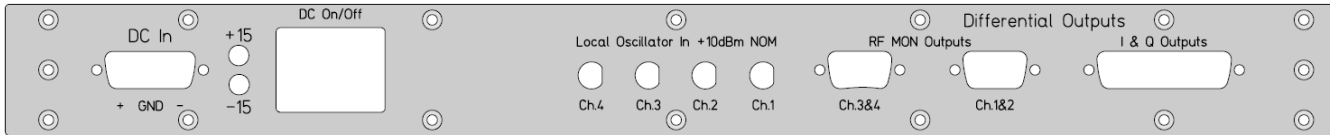

<< [L1-ISC-R1](#) ISC Whitening Chassis (ASC IMC WFS_A 24MHz) D1002559 Sxxxxxxx ±15VDC

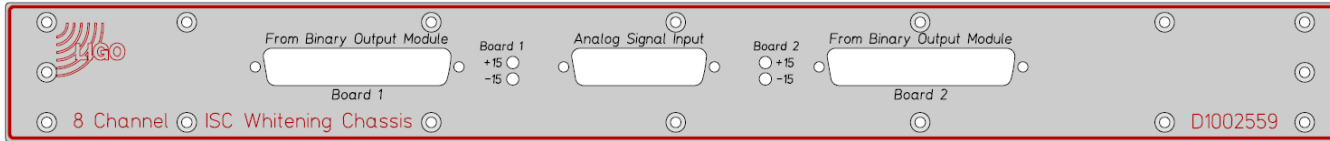

[D1002559](#)

Front

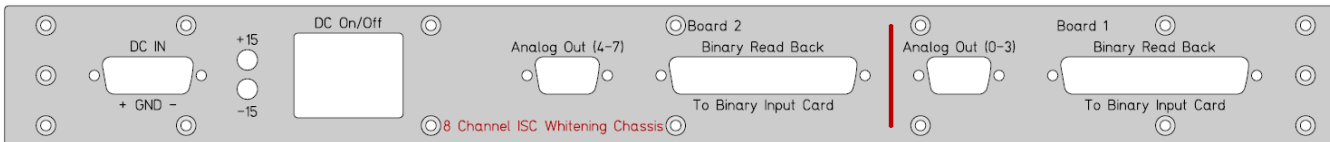

Sxxxxxxx

Rear

L1-ISC-R2 Details

L1-ISC-R3 Details

L1-ISC-R4 Details

L1-ISC-R5 Details

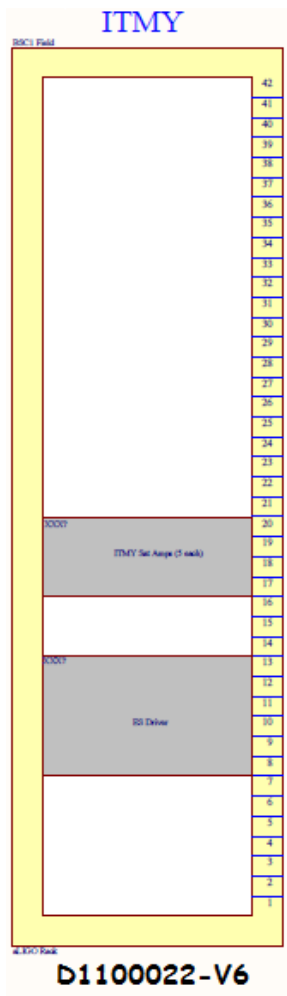

Satellite Amplifier
Satellite Amplifier
Satellite Amplifier
Satellite Amplifier
Satellite Amplifier

ES Driver

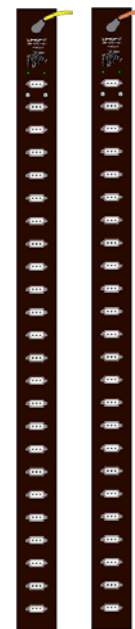
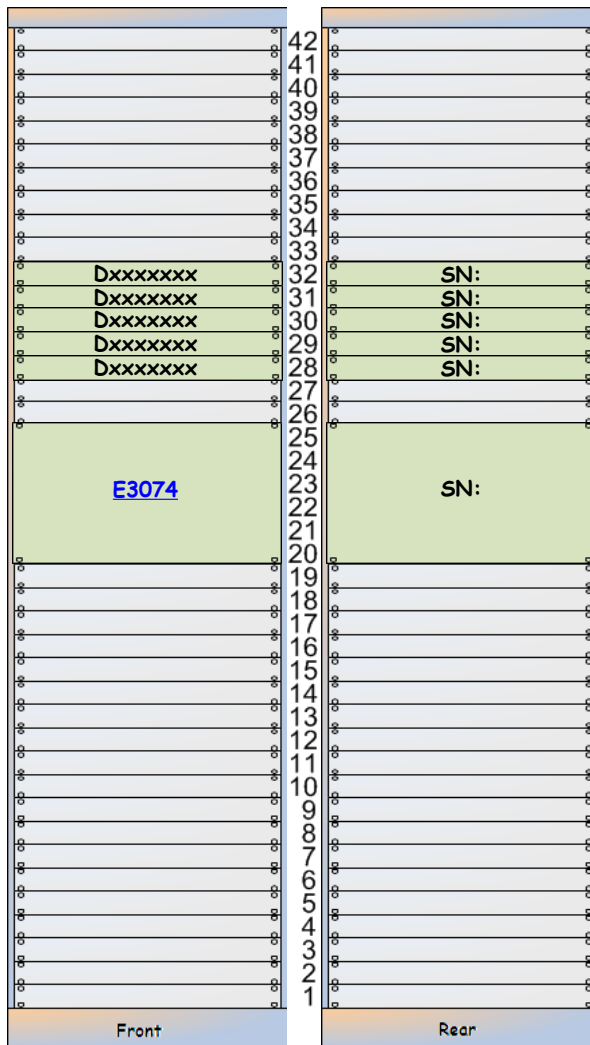

| | |
|--------|----|
| +18VDC | ?A |
| -18VDC | ?A |
| +24VDC | ?A |

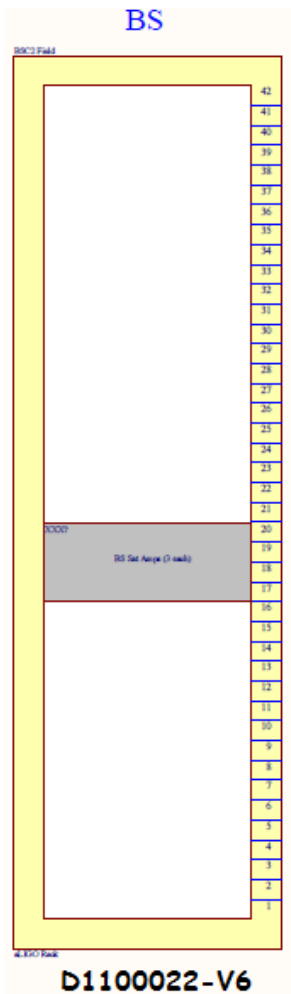

Satellite Amplifier
 Satellite Amplifier
 Satellite Amplifier
 Satellite Amplifier

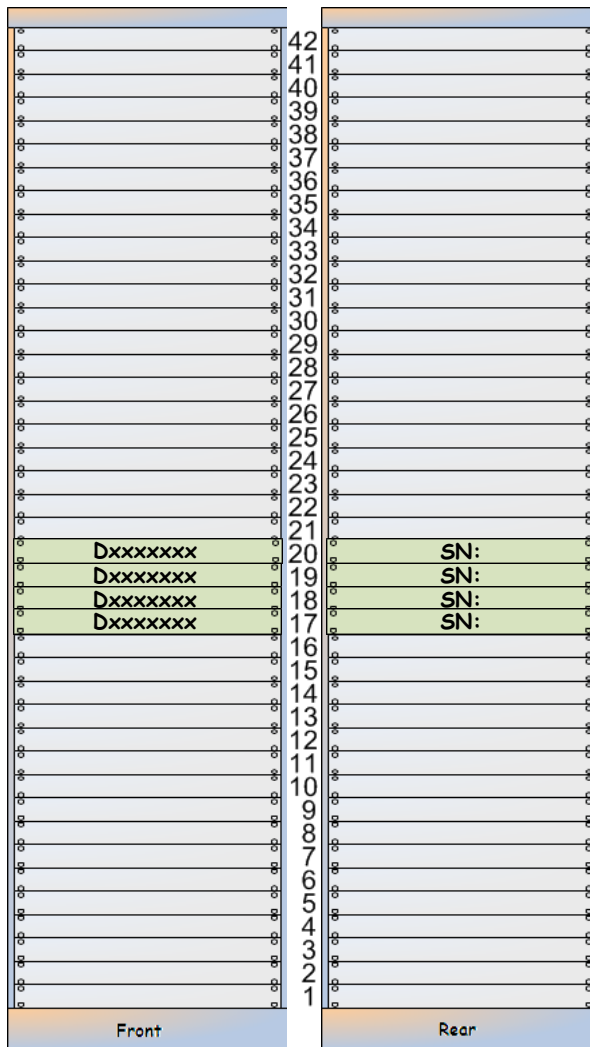

?@?A
 ?@?A
 ?@?A
 ?@?A

| | |
|--------|----|
| +18VDC | ?A |
| -18VDC | ?A |
| +24VDC | ?A |

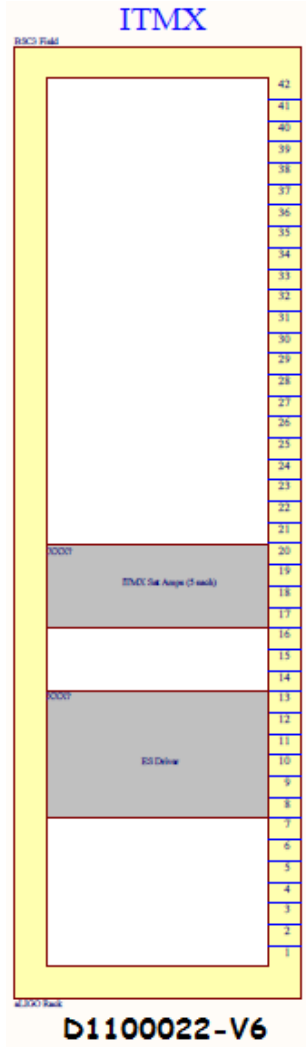

Satellite Amplifier
 Satellite Amplifier
 Satellite Amplifier
 Satellite Amplifier
 Satellite Amplifier

ES Driver

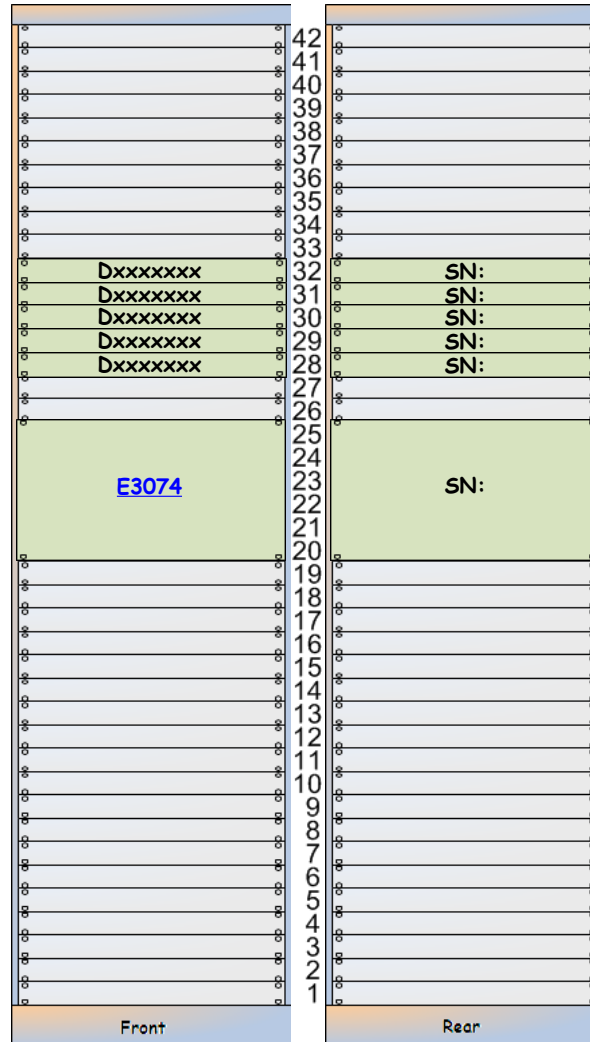

?@?A
 ?@?A
 ?@?A
 ?@?A
 ?@?A

+ -18VDC@0.4A
 + -430VDC@15mA

| | |
|--------|----|
| +18VDC | ?A |
| -18VDC | ?A |
| +24VDC | ?A |

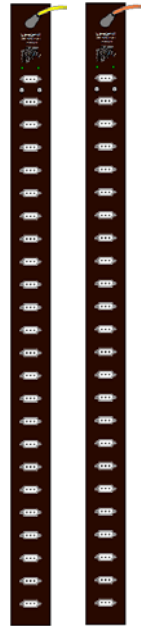

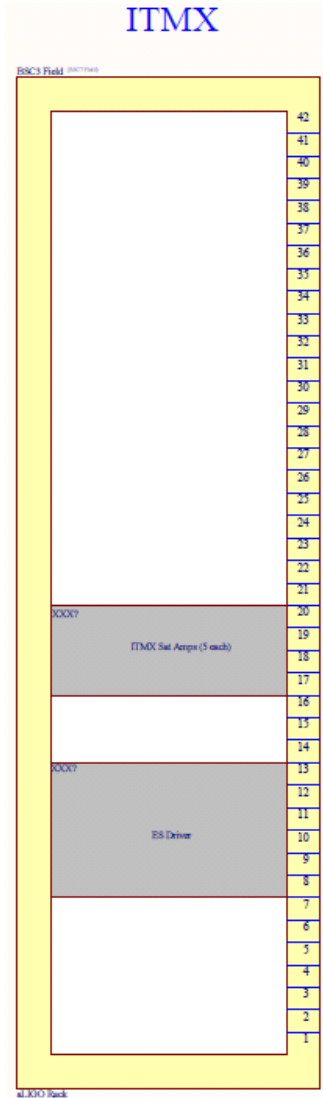

Satellite Amplifier
 Satellite Amplifier
 Satellite Amplifier

 Satellite Amplifier
 Satellite Amplifier
 Satellite Amplifier
 Satellite Amplifier
 Satellite Amplifier

ES Driver

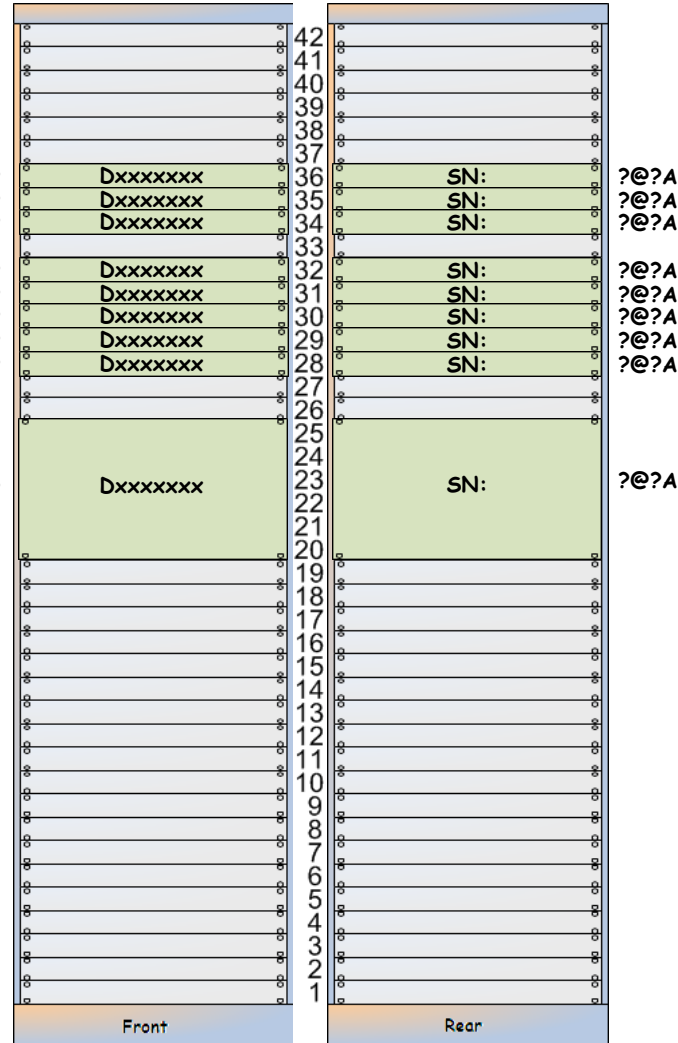

| | |
|--------|----|
| +18VDC | ?A |
| -18VDC | ?A |
| +24VDC | ?A |

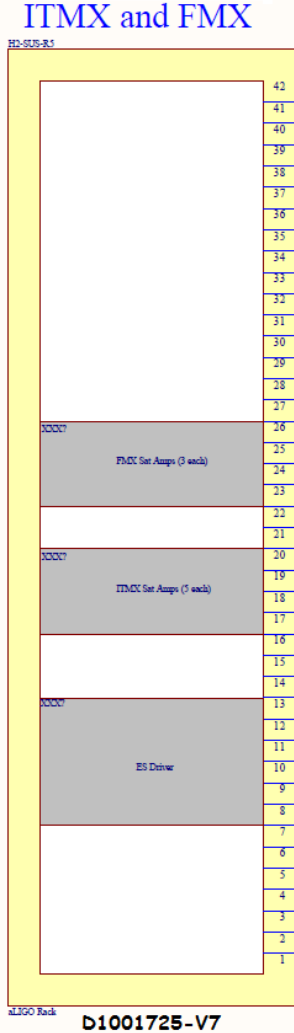

Satellite Amplifier
Satellite Amplifier
Satellite Amplifier

Satellite Amplifier
Satellite Amplifier
Satellite Amplifier
Satellite Amplifier
Satellite Amplifier

ES Driver

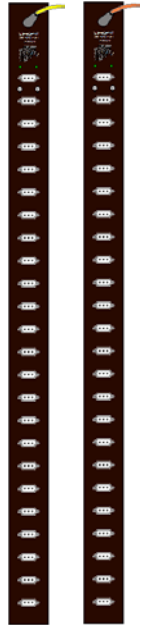
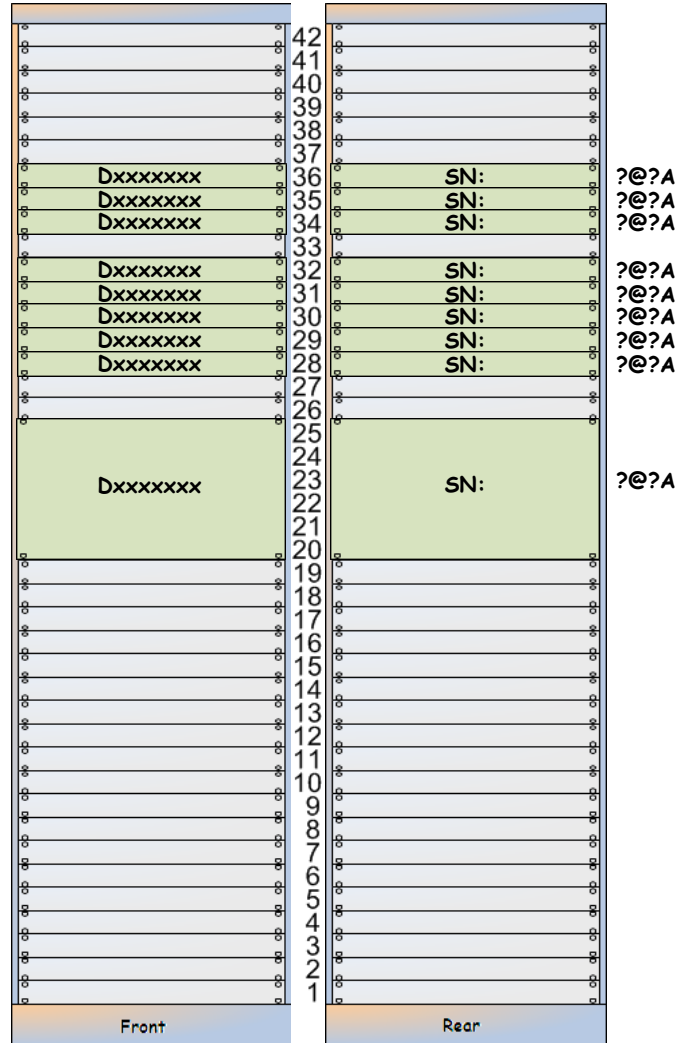

| | |
|--------|----|
| +18VDC | ?A |
| -18VDC | ?A |
| +24VDC | ?A |

ITMY, FMY and BS

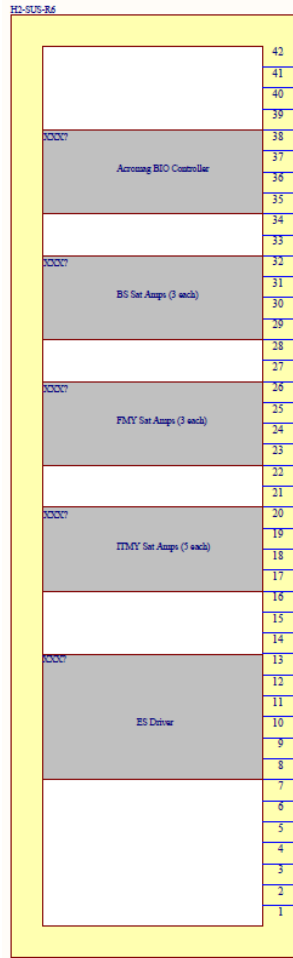

D1001725-V7

Satellite Amplifier
 Satellite Amplifier
 Satellite Amplifier

Satellite Amplifier
 Satellite Amplifier
 Satellite Amplifier
 Satellite Amplifier
 Satellite Amplifier

ES Driver

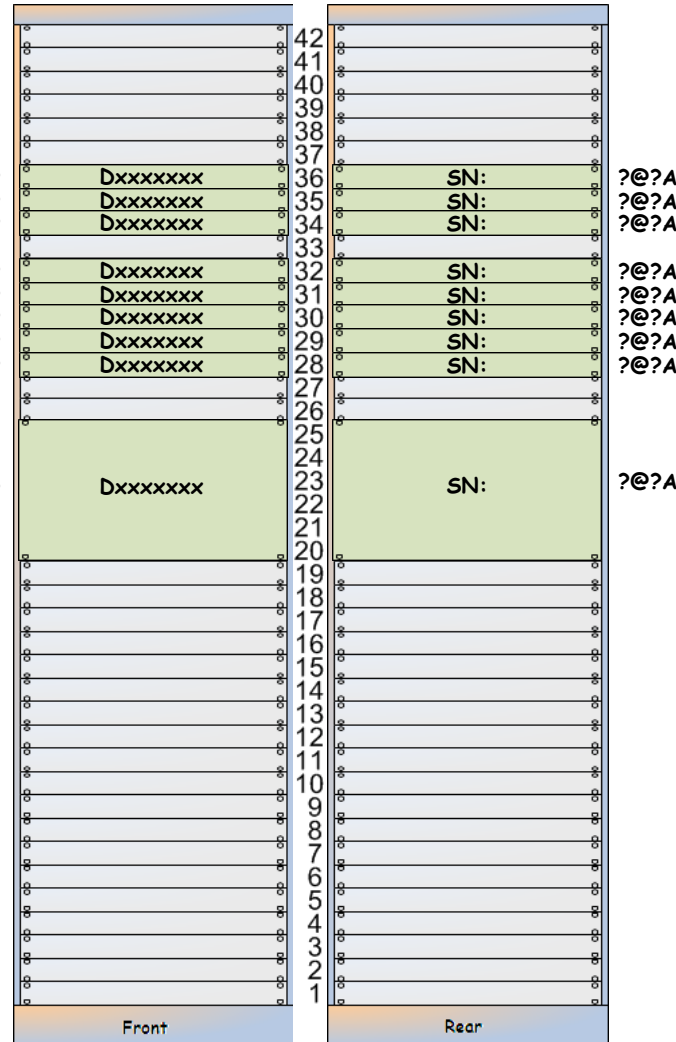

?@?A
 ?@?A
 ?@?A

?@?A
 ?@?A
 ?@?A
 ?@?A
 ?@?A

?@?A

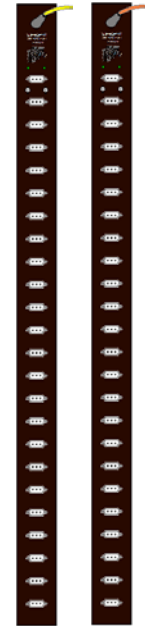

| | |
|--------|----|
| +18VDC | ?A |
| -18VDC | ?A |
| +24VDC | ?A |

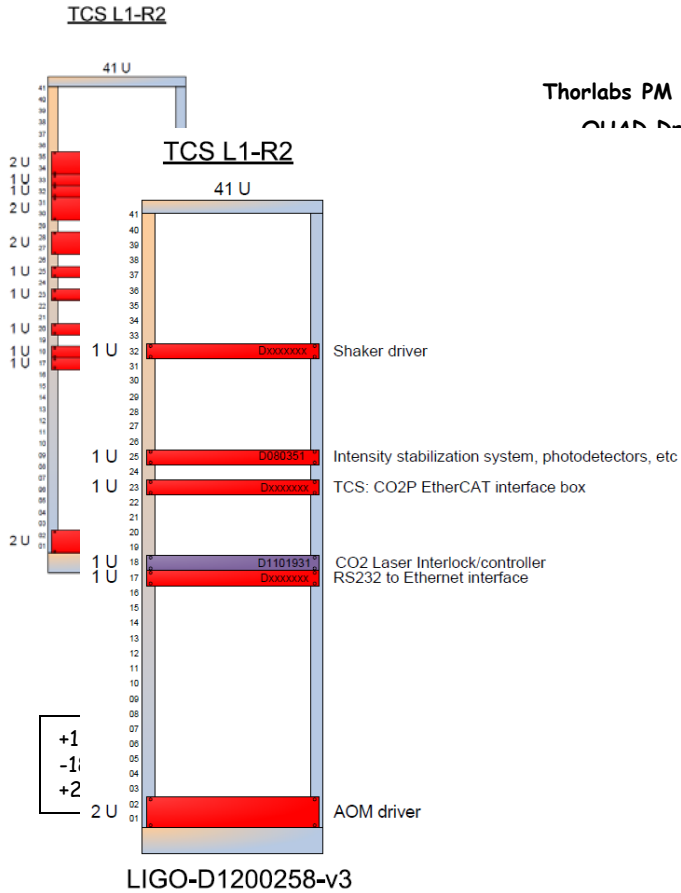

Thorlabs PM 100

QUAD Driver

iver

-CC

itor

tem

Box

tion

lock

ace

iver

iver

iver

iver

iver

iver

iver

iver

iver

iver

iver

iver

iver

iver

iver

iver

iver

iver

iver

iver

| | | | | |
|-------|----|------------|---------|------|
| | 42 | | | |
| | 41 | | | |
| | 40 | | | |
| | 39 | | | |
| | 38 | | | |
| | 37 | | | |
| | 36 | | | |
| | 35 | XXXXXXX | XXXXXXX | ?@?A |
| | 34 | D1101655 | SN: | ?@?A |
| | 33 | Dxxxxxxx | SN: | ?@?A |
| | 32 | SMC-100-CC | XXXXXXX | ?@?A |
| | 31 | | | |
| | 30 | | | |
| | 29 | | | |
| | 28 | XXXXXXX | XXXXXXX | ?@?A |
| | 27 | | | |
| | 26 | | | |
| | 25 | D080351 | SN: | ?@?A |
| | 24 | Dxxxxxxx | SN: | ?@?A |
| | 23 | | | |
| | 22 | | | |
| | 21 | Dxxxxxxx | SN: | ?@?A |
| | 20 | | | |
| | 19 | | | |
| | 18 | D1101931 | SN: | ?@?A |
| | 17 | Dxxxxxxx | SN: | ?@?A |
| | 16 | | | |
| | 15 | | | |
| | 14 | | | |
| | 13 | | | |
| | 12 | | | |
| | 11 | | | |
| | 10 | | | |
| | 9 | | | |
| | 8 | | | |
| | 7 | | | |
| | 6 | | | |
| | 5 | | | |
| | 4 | | | |
| | 3 | | | |
| | 2 | Dxxxxxxx | SN: | ?@?A |
| | 1 | | | |
| Front | | | | |
| Rear | | | | |

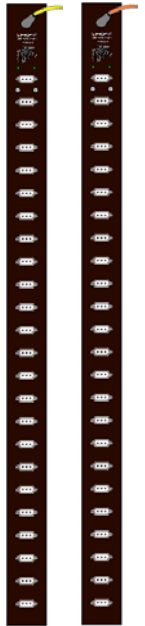

LVEA VAC <X> Rack Layout (LIGO-Dxxxxxxx)

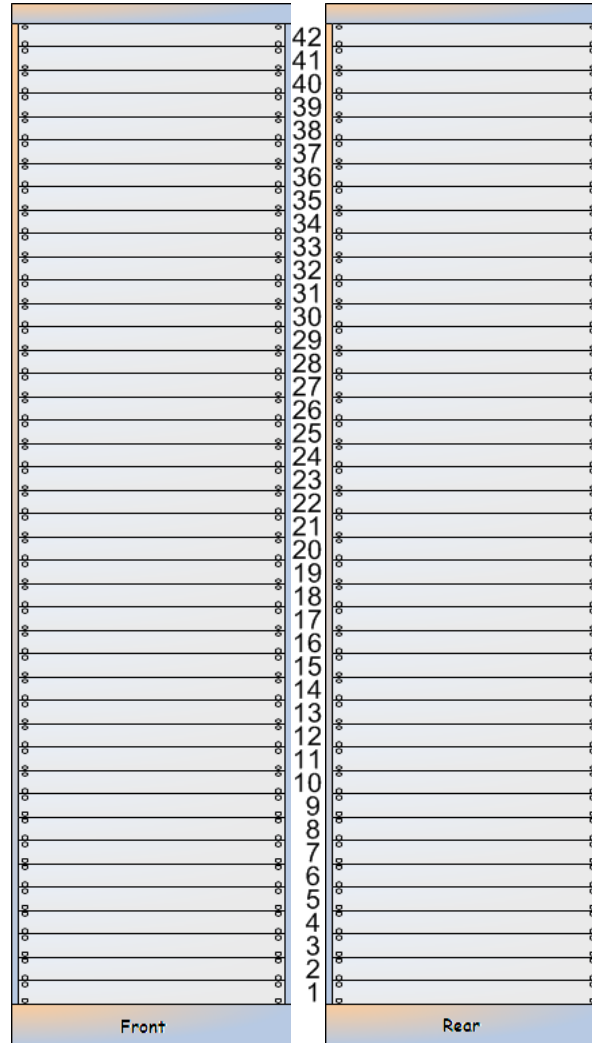

| | |
|--------|----|
| +18VDC | ?A |
| -18VDC | ?A |
| +24VDC | ?A |

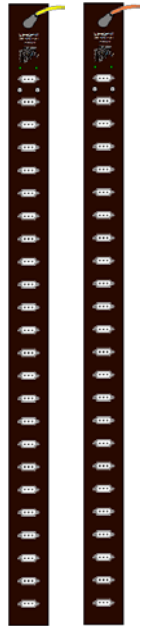

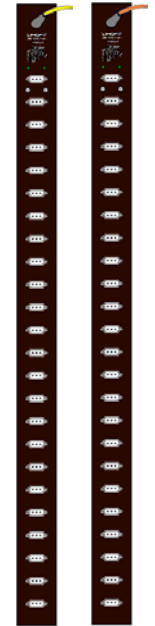
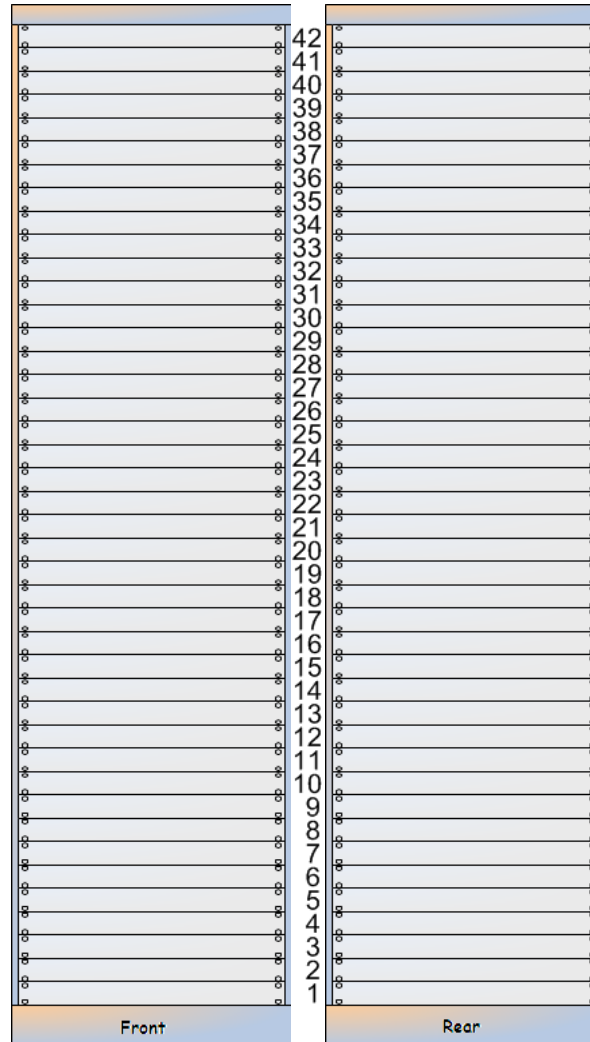

| | |
|--------|----|
| +18VDC | ?A |
| -18VDC | ?A |
| +24VDC | ?A |

LVEA VAC <Mech> Rack Layout (LIGO-Dxxxxxxx)

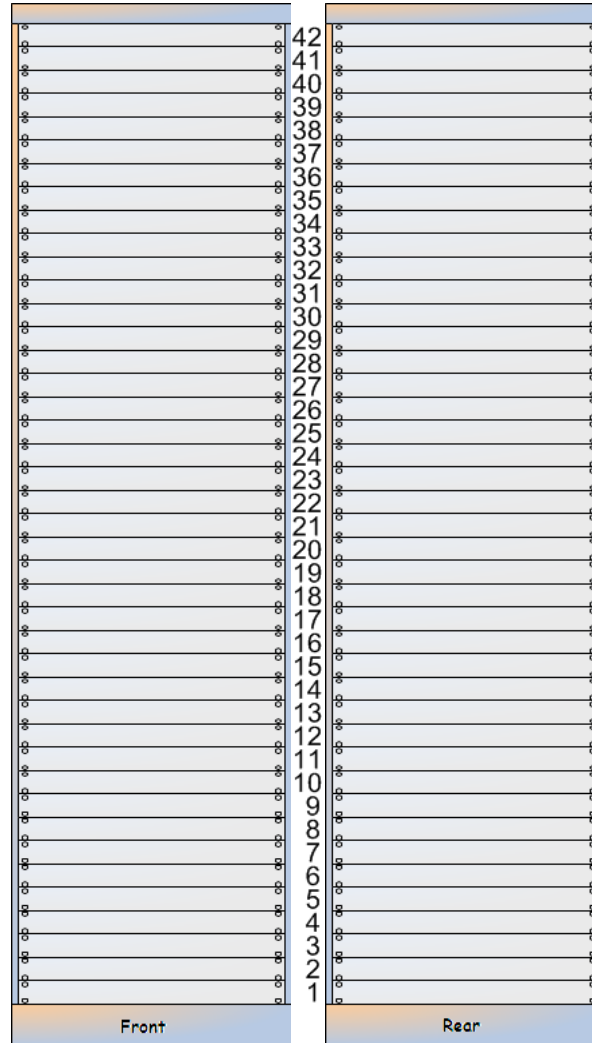

| | |
|--------|----|
| +18VDC | ?A |
| -18VDC | ?A |
| +24VDC | ?A |



[<< LLO Map](#)

[<< LLO Racks by AREA](#)

[<< LLO CDS Components](#)

VEAX

X-End Station Rack Layout

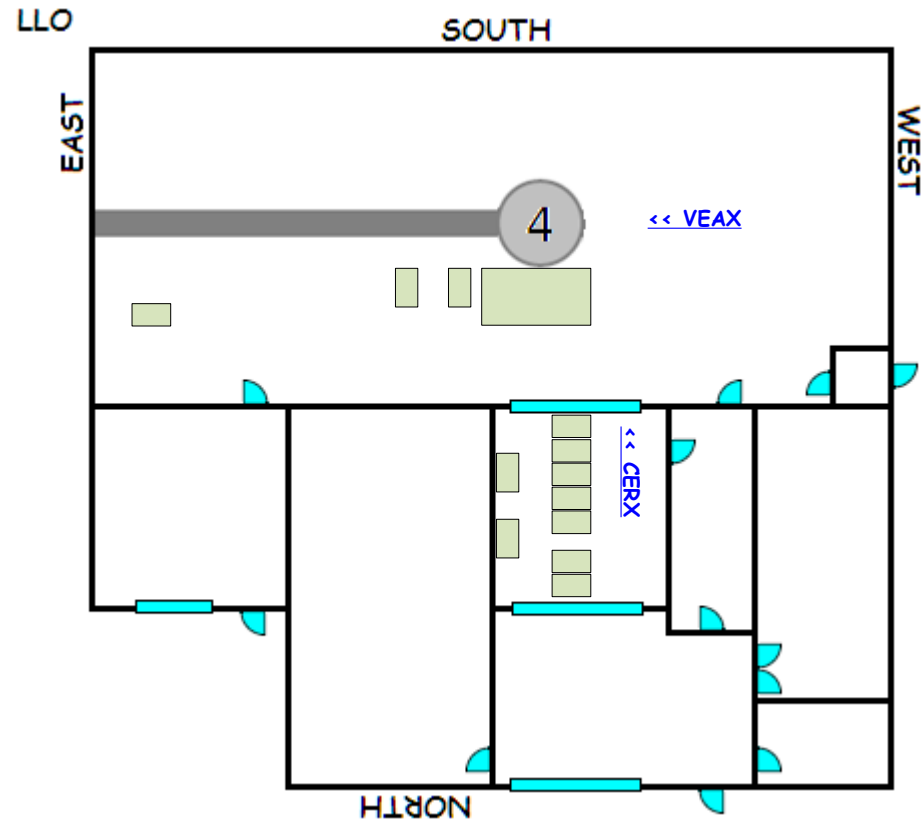

X-End Station Rack Layout

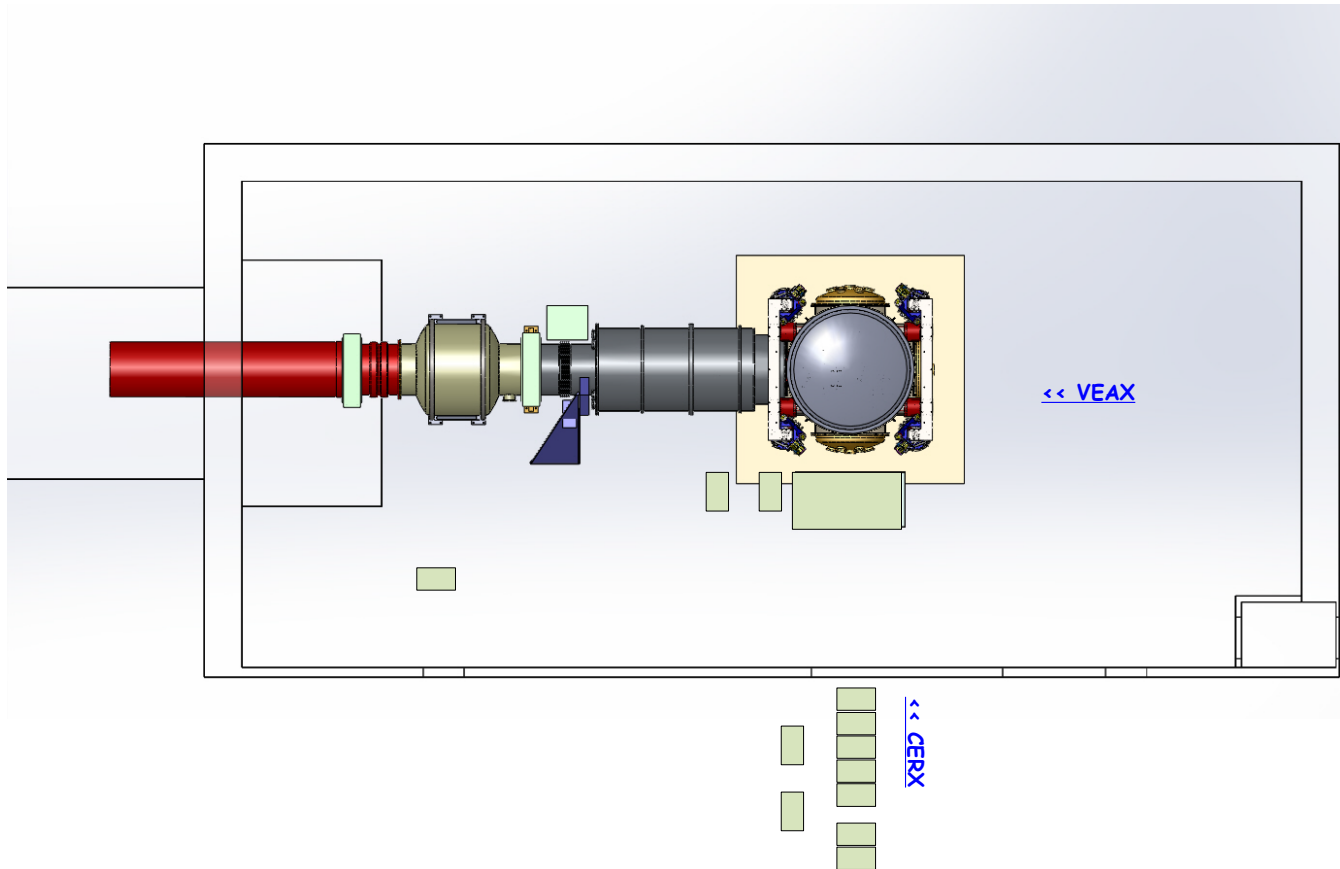

X-End - D0901465

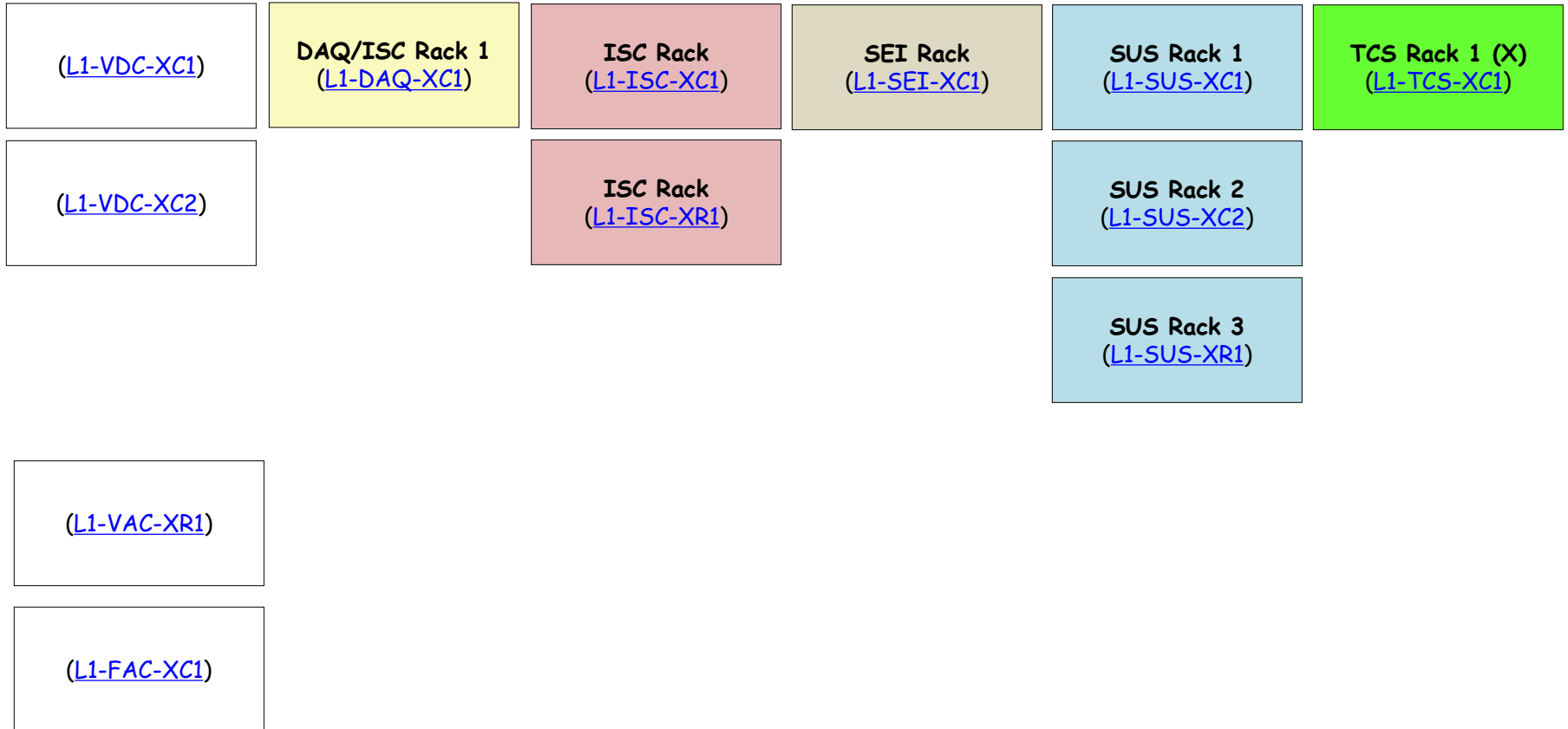

<< X-End Racks

It is 70' from the L1-FAC-XC1 Rack to the knee of the waterfall in the VEAX.

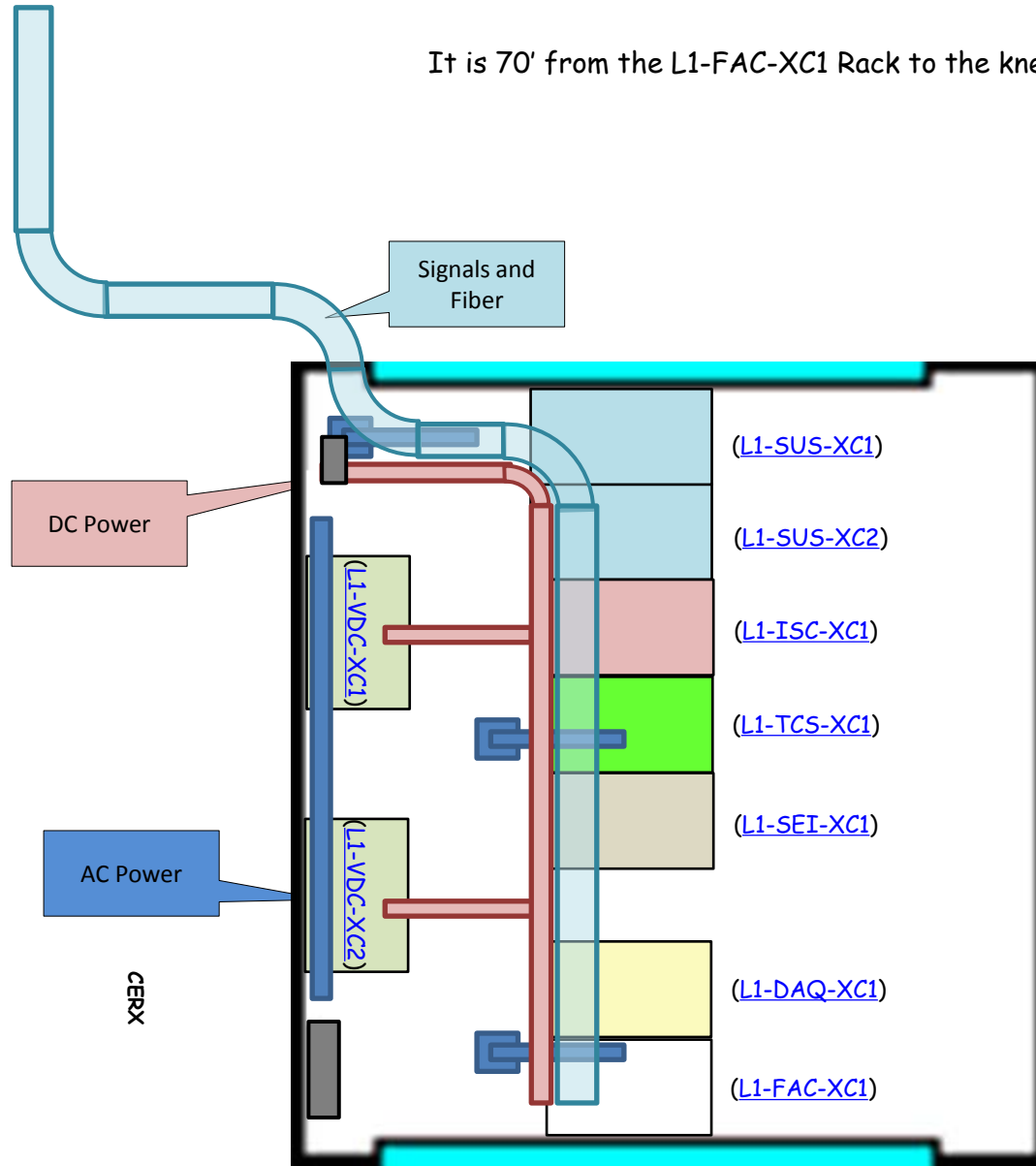

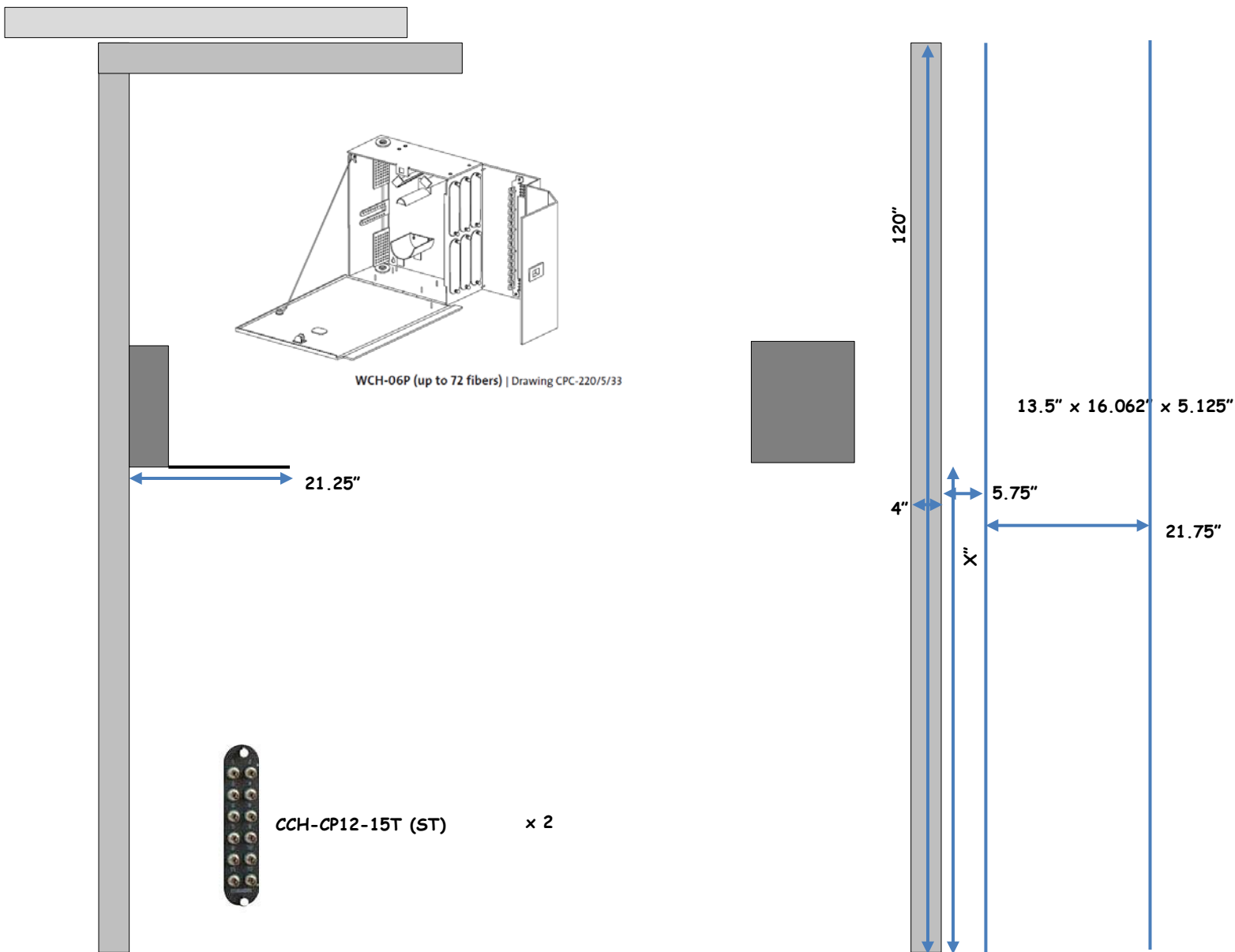

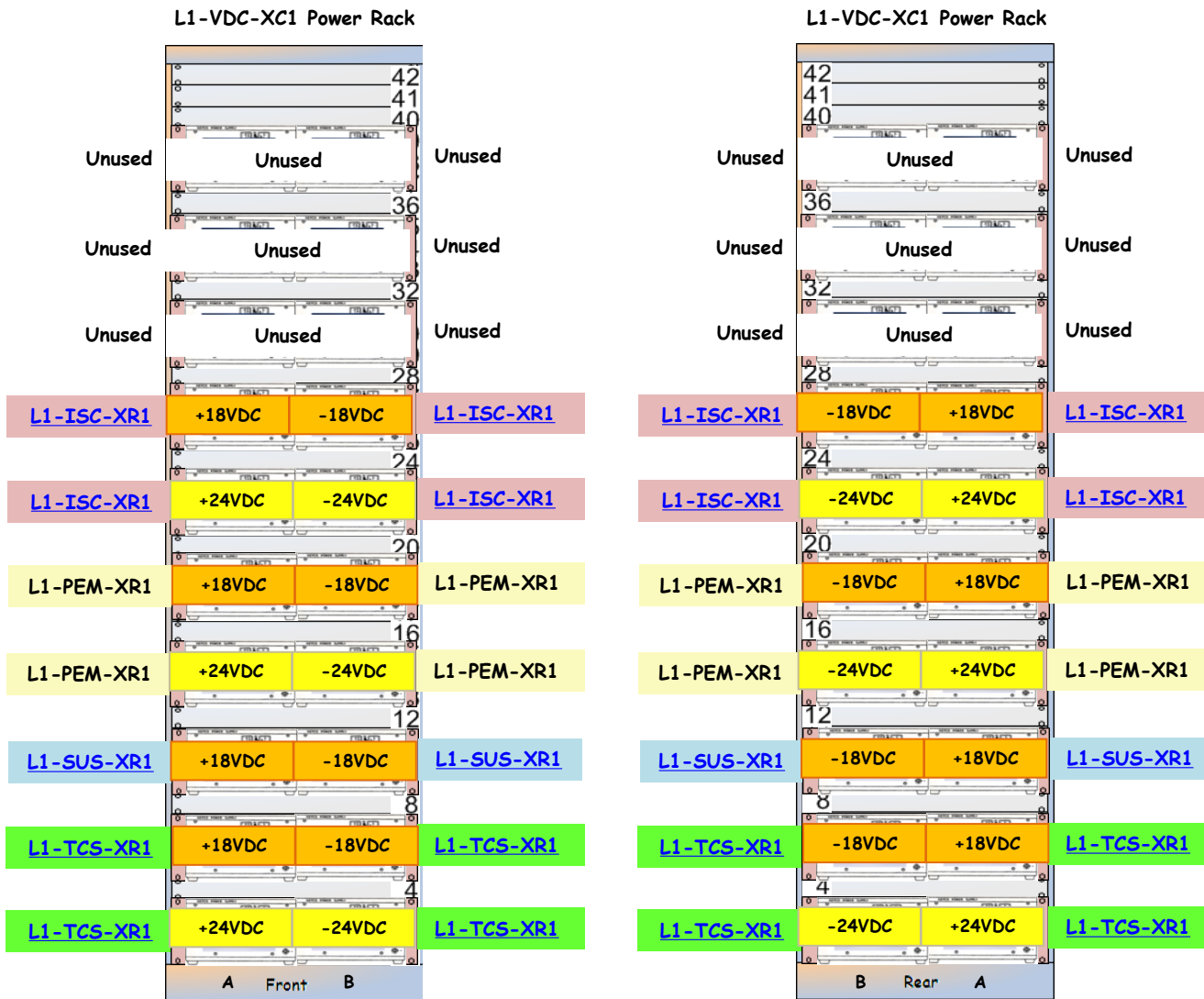

L1-VDC-XC2 Power Racks - VEAX Supplies

<< CERX Racks

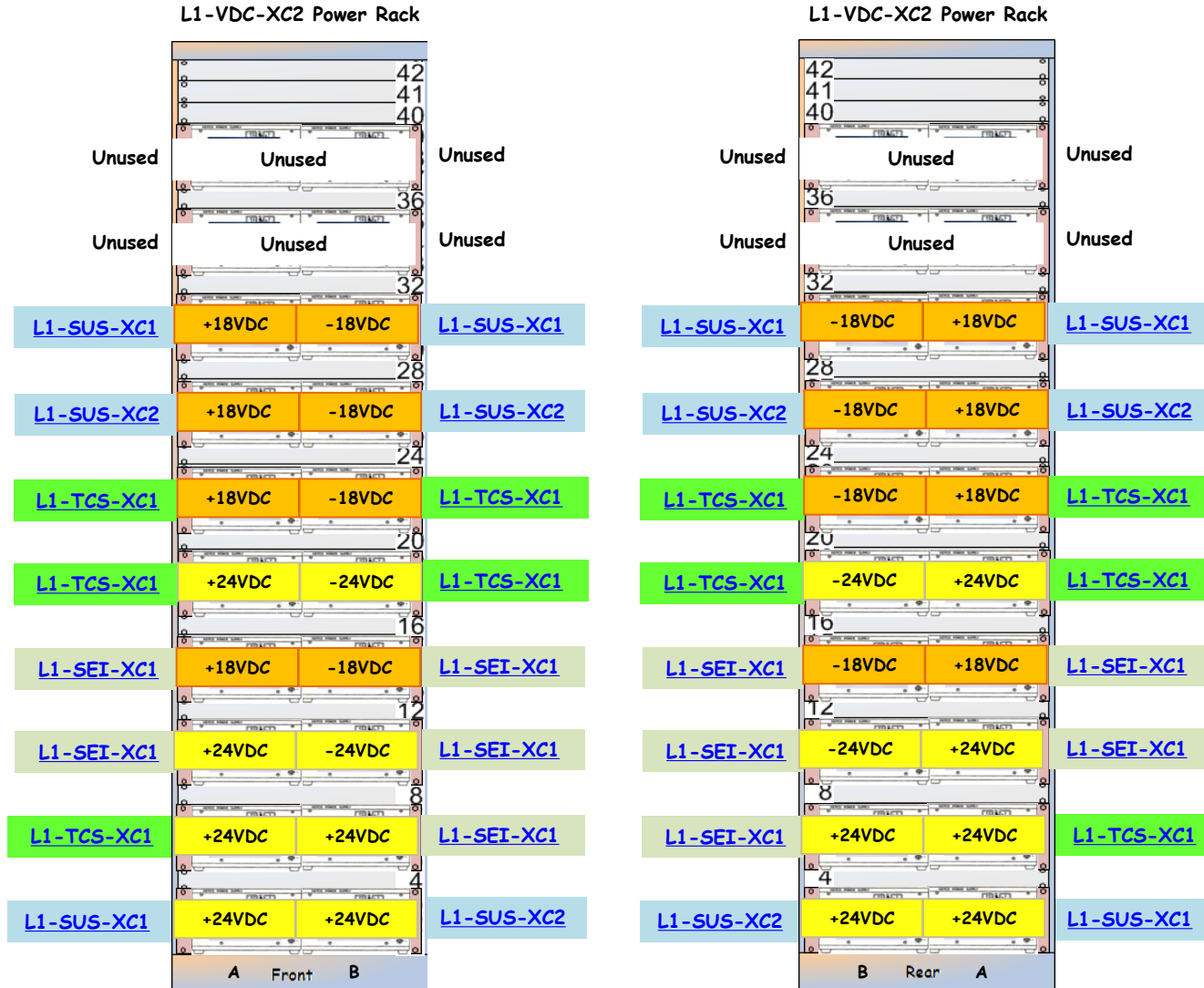

[Cable Runs >>](#)

L1-VDC-XC1 Cable Runs

<< L1-VDC-XC1

| | Power Panel | Circuit | DC Power Rack | Outlet | Plug Position | Rack U | DC Power Supply | Polarity | DC Extension Cable | Electronics Rack | DC Power Strip |
|----|-------------|---------|---------------|--------|---------------|---------------|-----------------|----------|--------------------|------------------|----------------|
| 1 | CDS-X | | L1-VDC-XC1 | 08 | Top | U37-A (Left) | | | | | |
| 2 | CDS-X | | L1-VDC-XC1 | 08 | Bottom | U37-B (Right) | | | | | |
| 3 | CDS-X | | L1-VDC-XC1 | 02 | Top | U33-A (Left) | | | | | |
| 4 | CDS-X | | L1-VDC-XC1 | 02 | Bottom | U33-B (Right) | | | | | |
| 5 | CDS-X | | L1-VDC-XC1 | 09 | Top | U29-A (Left) | | | | | |
| 6 | CDS-X | | L1-VDC-XC1 | 09 | Bottom | U29-B (Right) | | | | | |
| 7 | CDS-X | | L1-VDC-XC1 | 03 | Top | U25-A (Left) | | Plus | PTO-038 | L1-ISC-XR1 | PSO-038 |
| 8 | CDS-X | | L1-VDC-XC1 | 03 | Bottom | U25-B (Right) | | Minus | PTO-038 | L1-ISC-XR1 | PSO-038 |
| 9 | CDS-X | | L1-VDC-XC1 | 10 | Top | U21-A (Left) | | Plus | PTY-028 | L1-ISC-XR1 | PSY-028 |
| 10 | CDS-X | | L1-VDC-XC1 | 10 | Bottom | U21-B (Right) | | Minus | PTY-028 | L1-ISC-XR1 | PSY-028 |
| 11 | CDS-X | | L1-VDC-XC1 | 04 | Top | U17-A (Left) | | Plus | PTO-039 | L1-PEM-XR1 | PSO-039 |
| 12 | CDS-X | | L1-VDC-XC1 | 04 | Bottom | U17-B (Right) | | Minus | PTO-039 | L1-PEM-XR1 | PSO-039 |
| 13 | CDS-X | | L1-VDC-XC1 | 11 | Top | U13-A (Left) | | Plus | PTY-029 | L1-PEM-XR1 | PSY-029 |
| 14 | CDS-X | | L1-VDC-XC1 | 11 | Bottom | U13-B (Right) | | Minus | PTY-029 | L1-PEM-XR1 | PSY-029 |
| 15 | CDS-X | | L1-VDC-XC1 | 05 | Top | U09-A (Left) | | Plus | PTO-040 | L1-SUS-XR1 | PSO-040 |
| 16 | CDS-X | | L1-VDC-XC1 | 05 | Bottom | U09-B (Right) | | Minus | PTO-040 | L1-SUS-XR1 | PSO-040 |
| 17 | CDS-X | | L1-VDC-XC1 | 12 | Top | U05-A (Left) | | Plus | PTO-041 | L1-TCS-XR1 | PSO-041 |
| 18 | CDS-X | | L1-VDC-XC1 | 12 | Bottom | U05-B (Right) | | Minus | PTO-041 | L1-TCS-XR1 | PSO-041 |
| 19 | CDS-X | | L1-VDC-XC1 | 06 | Top | U01-A (Left) | | Plus | PTY-030 | L1-TCS-XR1 | PSY-030 |
| 20 | CDS-X | | L1-VDC-XC1 | 06 | Bottom | U01-B (Right) | | Minus | PTY-030 | L1-TCS-XR1 | PSY-030 |

L1-VDC-XC2 Cable Runs

<< L1-VDC-XC2

| | Power Panel | Circuit | DC Power Rack | Outlet | Plug Position | Rack U | DC Power Supply | Polarity | DC Extension Cable | Electronics Rack | DC Power Strip |
|----|-------------|---------|---------------|--------|---------------|---------------|-----------------|----------|--------------------|------------------|----------------|
| 1 | CDS-X | | L1-VDC-XC2 | 08 | Top | U37-A (Left) | | | | | |
| 2 | CDS-X | | L1-VDC-XC2 | 08 | Bottom | U37-B (Right) | | | | | |
| 3 | CDS-X | | L1-VDC-XC2 | 02 | Top | U33-A (Left) | | | | | |
| 4 | CDS-X | | L1-VDC-XC2 | 02 | Bottom | U33-B (Right) | | | | | |
| 5 | CDS-X | | L1-VDC-XC2 | 09 | Top | U29-A (Left) | | Plus | PTO-042 | L1-SUS-XC1 | PSO-042 |
| 6 | CDS-X | | L1-VDC-XC2 | 09 | Bottom | U29-B (Right) | | Minus | PTO-042 | L1-SUS-XC1 | PSO-042 |
| 7 | CDS-X | | L1-VDC-XC2 | 03 | Top | U25-A (Left) | | Plus | PTO-043 | L1-SUS-XC2 | PSO-043 |
| 8 | CDS-X | | L1-VDC-XC2 | 03 | Bottom | U25-B (Right) | | Minus | PTO-043 | L1-SUS-XC2 | PSO-043 |
| 9 | CDS-X | | L1-VDC-XC2 | 10 | Top | U21-A (Left) | | Plus | PTO-044 | L1-TCS-XC1 | PSO-044 |
| 10 | CDS-X | | L1-VDC-XC2 | 10 | Bottom | U21-B (Right) | | Minus | PTO-044 | L1-TCS-XC1 | PSO-044 |
| 11 | CDS-X | | L1-VDC-XC2 | 04 | Top | U17-A (Left) | | Plus | PTY-031 | L1-TCS-XC1 | PSY-031 |
| 12 | CDS-X | | L1-VDC-XC2 | 04 | Bottom | U17-B (Right) | | Minus | PTY-031 | L1-TCS-XC1 | PSY-031 |
| 13 | CDS-X | | L1-VDC-XC2 | 11 | Top | U13-A (Left) | | Plus | PTO-045 | L1-SEI-XC1 | PSO-045 |
| 14 | CDS-X | | L1-VDC-XC2 | 11 | Bottom | U13-B (Right) | | Minus | PTO-045 | L1-SEI-XC1 | PSO-045 |
| 15 | CDS-X | | L1-VDC-XC2 | 05 | Top | U09-A (Left) | | Plus | PTY-032 | L1-SEI-XC1 | PSY-032 |
| 16 | CDS-X | | L1-VDC-XC2 | 05 | Bottom | U09-B (Right) | | Minus | PTY-032 | L1-SEI-XC1 | PSY-032 |
| 17 | CDS-X | | L1-VDC-XC2 | 12 | Top | U05-A (Left) | | Plus | PTY-033 | L1-TCS-XC1 | PSY-033 |
| 18 | CDS-X | | L1-VDC-XC2 | 12 | Bottom | U05-B (Right) | | Plus | PTY-034 | L1-SEI-XC1 | PSY-034 |
| 19 | CDS-X | | L1-VDC-XC2 | 06 | Top | U01-A (Left) | | Plus | PTY-035 | L1-SUS-XC1 | PSY-035 |
| 20 | CDS-X | | L1-VDC-XC2 | 06 | Bottom | U01-B (Right) | | Plus | PTY-036 | L1-SUS-XC2 | PSY-036 |

L1-DAQ-XC1 (Temporary)

<< CERX Racks

DAQ/ISC <X> End Station Remote Rack Layout (LIGO-Dxxxxxxx)

[ACC 5595 Reflective Memory Hub](#)
[l1lanfex 10.199.0.13](#)
[l1netfedaqx 10.199.0.87](#)

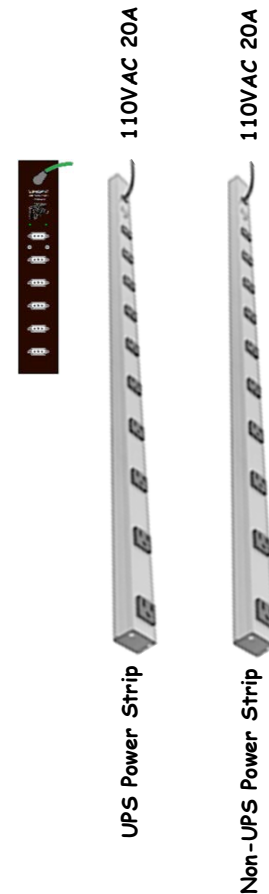
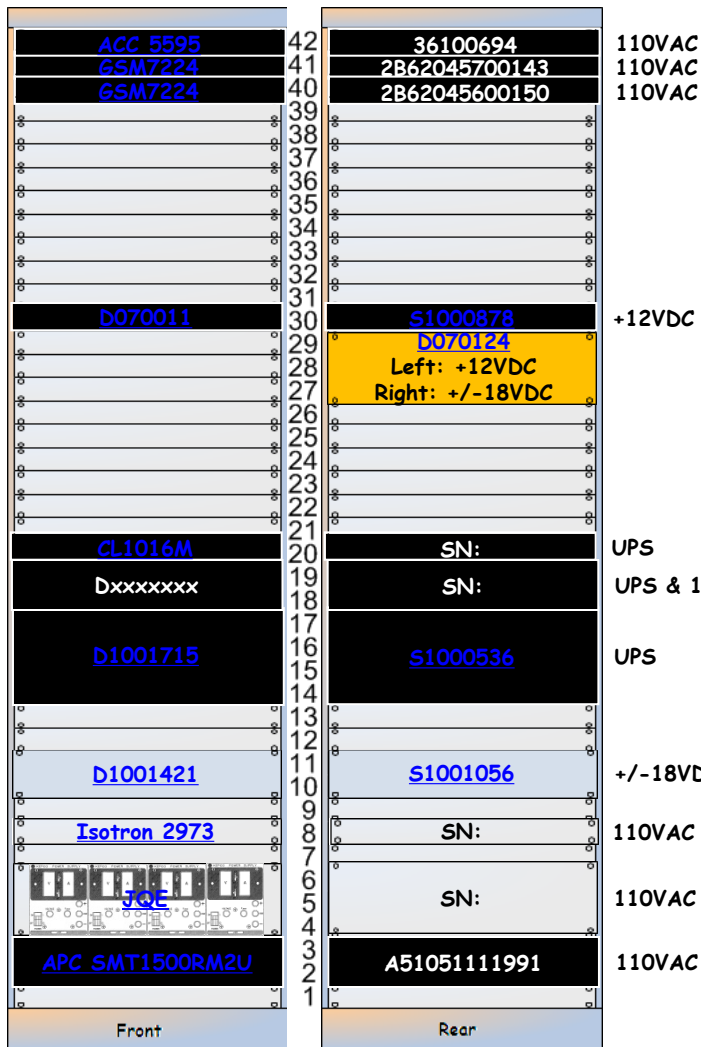

Needs DC
Needs cover

[Timing Fanout](#)
[D070011](#)
[ATEN KVM Switch](#)
[l1pemex Front End Computer](#)
[l1pemex I/O Extension Chassis](#)

[aLIGO AA Interface Chassis \(32 BNC x10 Gain Version\)](#)
[D1001421](#)
[Accelerometer Power Supply](#)
[Isotron 2973](#)

Power Supplies:
 Kepco JQE15-12M
 SN:
 H114642
 H114633
 H114648
 H114649

[KEPCO Power Supplies](#)
[UPS](#)
[APC SMT1500RM2U](#)



[D070011](#)

Front

To 1X23 PP B4, B5

To 11pinex IO Front Panel



[S1000878](#)

Rear

To D070124 Green Cable



CL1016M

Front



Z8A6Y132ANQ0010

Rear

To UPS Power Strip

To L1 pemex Front End

I1pemex - Front End

I1pemex - Front End

Front End

SN:

110VAC



To UPS Power Strip



To I1pemex Front End

l1pemex I/O Extension Chassis

D1001715

S1000536

110VAC



D1001715

Front

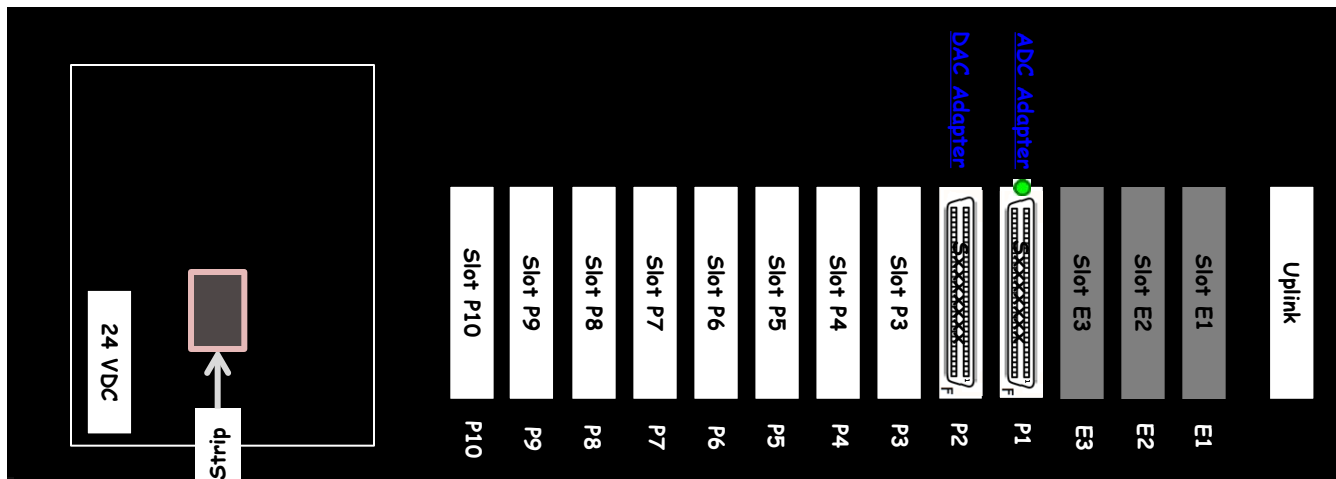

S1000536

Rear

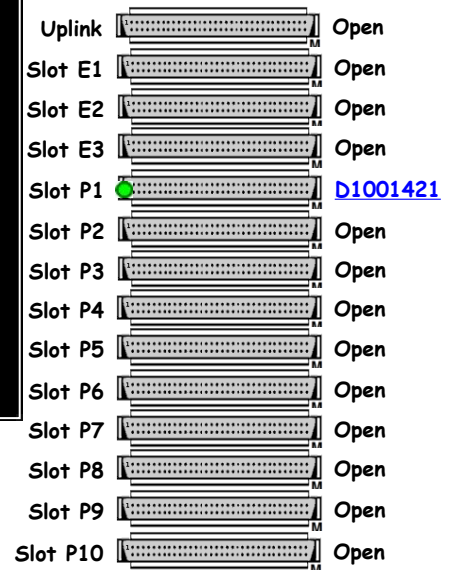

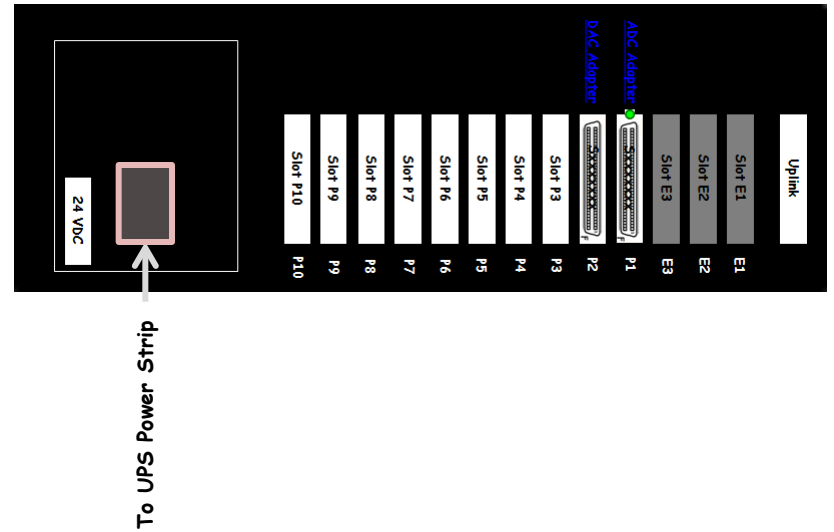
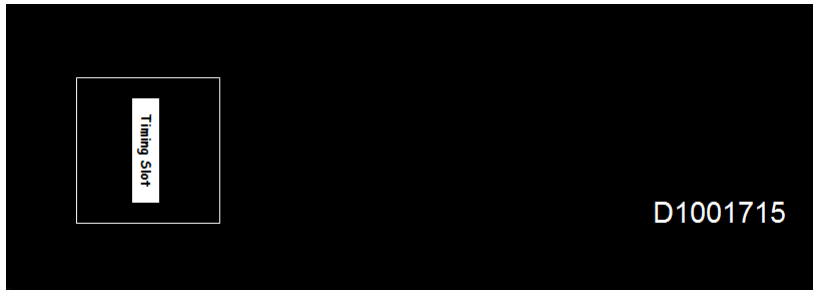

<< L1-PEM-XC1

aLIGO AA Interface Chassis
(32 BNC, x10 Gain Version)

D1001421

SN:

Power

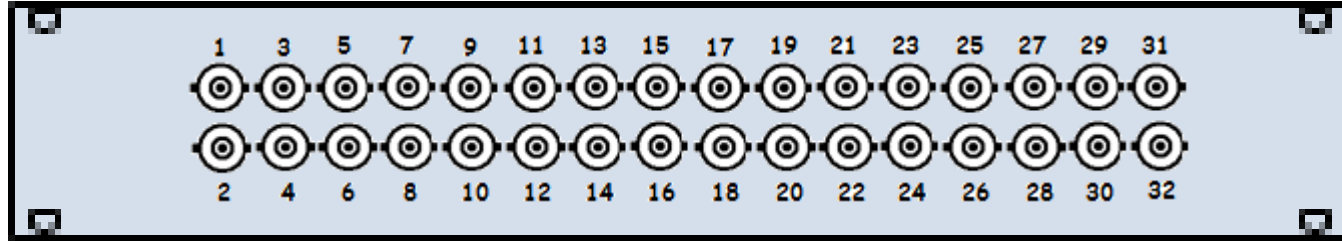

D1001421

Front

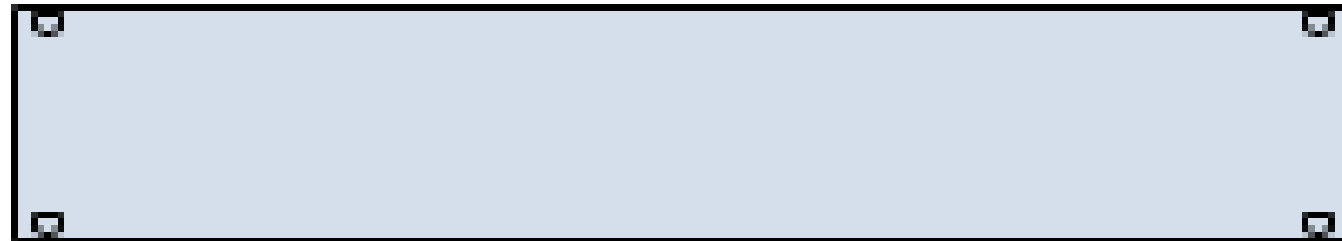
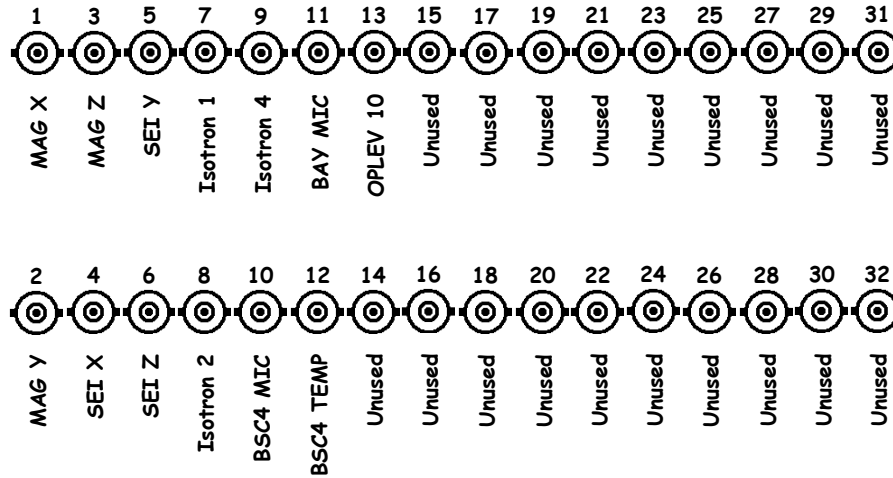

SN:

Rear

aLIGO Accelerometer Interface Chassis

D1101363

SN:

Power

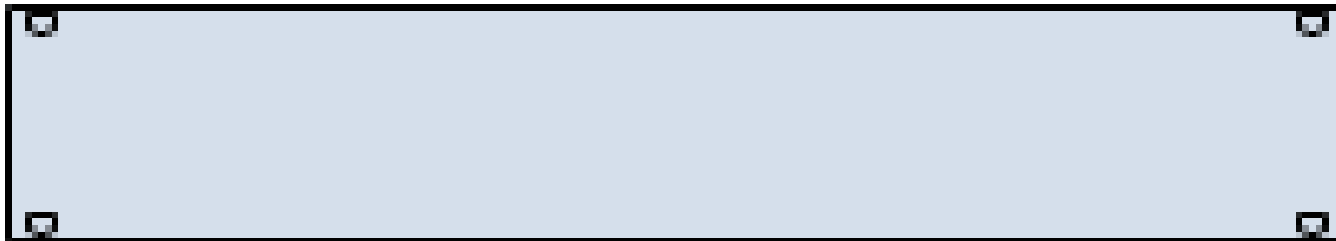
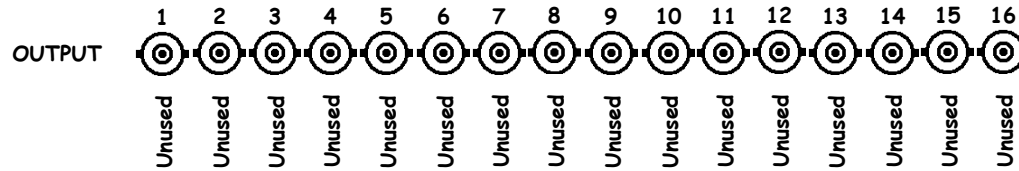
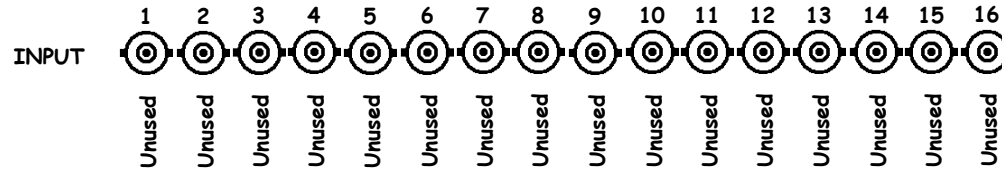
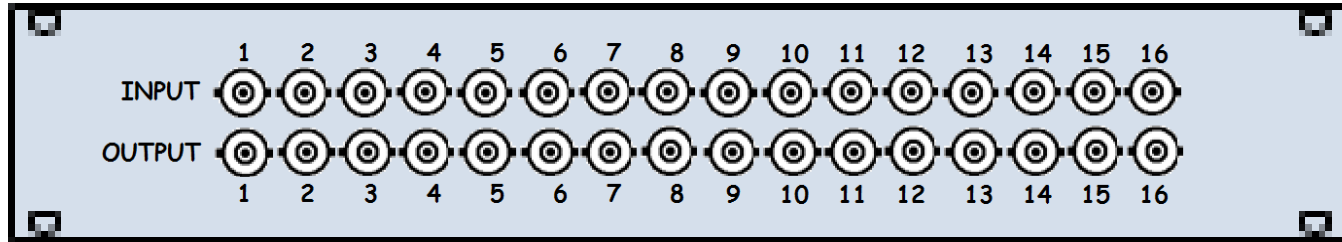

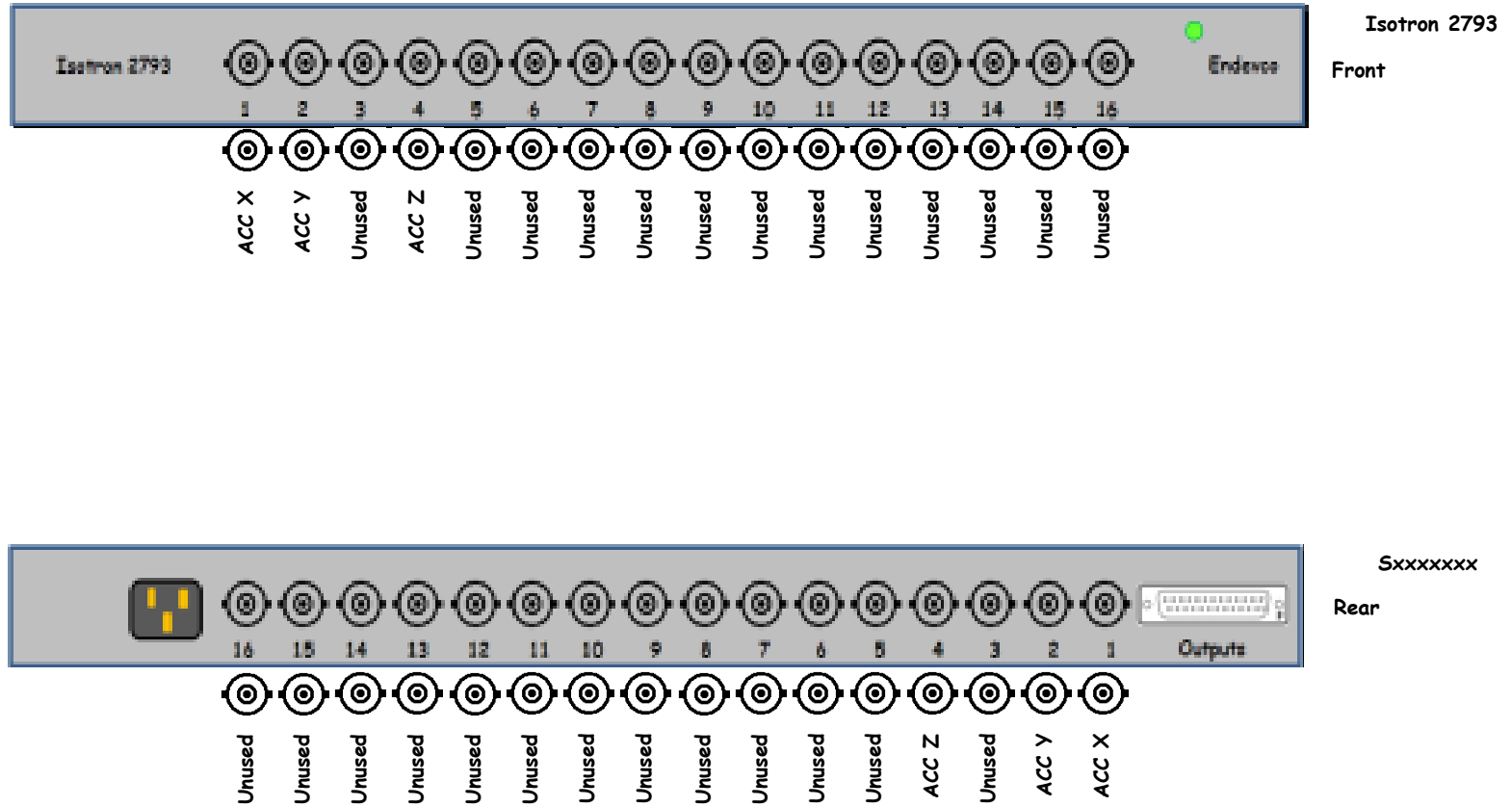

Isotron 2793

Front

Sxxxxxxx

Rear

<< L1-PEM-XC1

KEPCO Power Supplies



110VAC

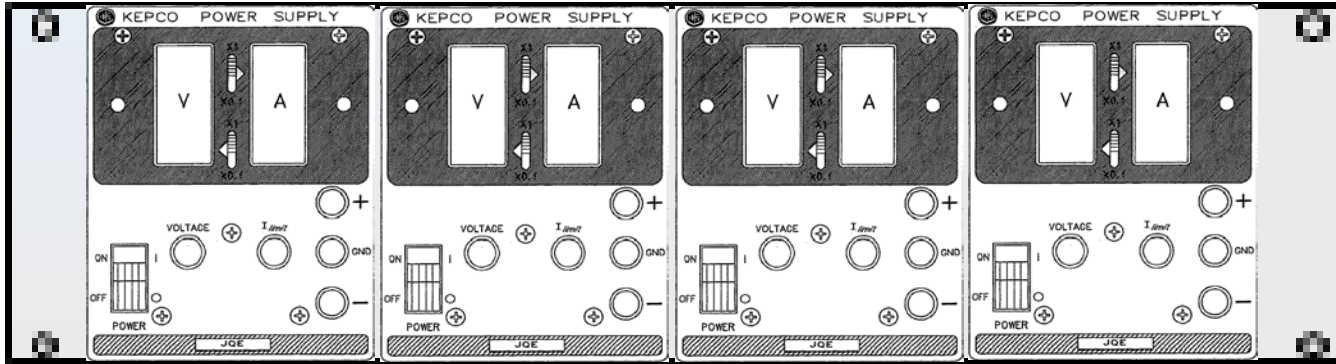

JQE

Front

KEPCO JQE 15-6:
OFF (Not Used)

KEPCO JQE 15-6:
+12VDC

KEPCO JQE 25-4:
-18VDC

KEPCO JQE 25-4:
+18VDC

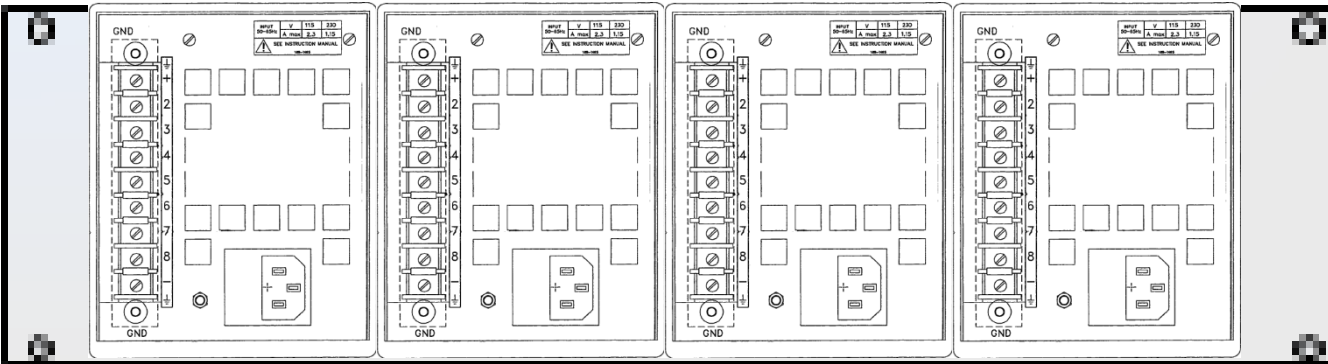

SN:

Rear

KEPCO JQE 25-4

KEPCO JQE 25-4

KEPCO JQE 15-6

KEPCO JQE 15-6

APC SMX2000RMLV2U

UPS

[APC SMX2000RMLV2U](#)

JS1048019433

110VAC



[APC SMX2000RMLV2U](#)

Front

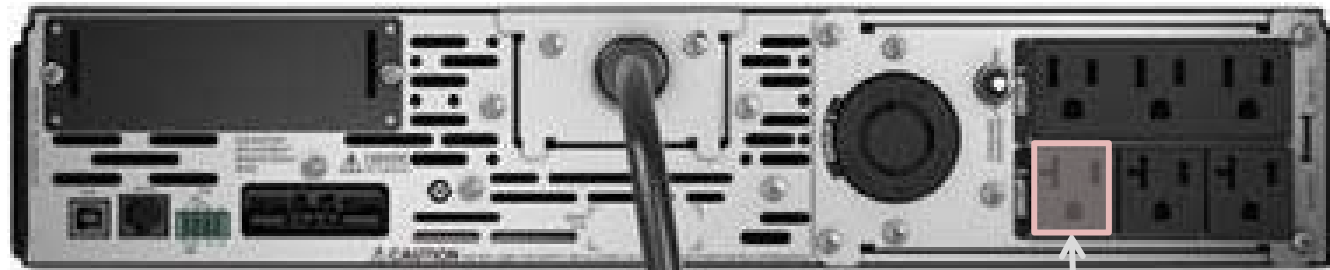

JS1048019433

Rear

[To UPS Power Strip](#)

APC SMT2200RM2U

UPS

APC SMT1500RM2U

A51051111991

110VAC

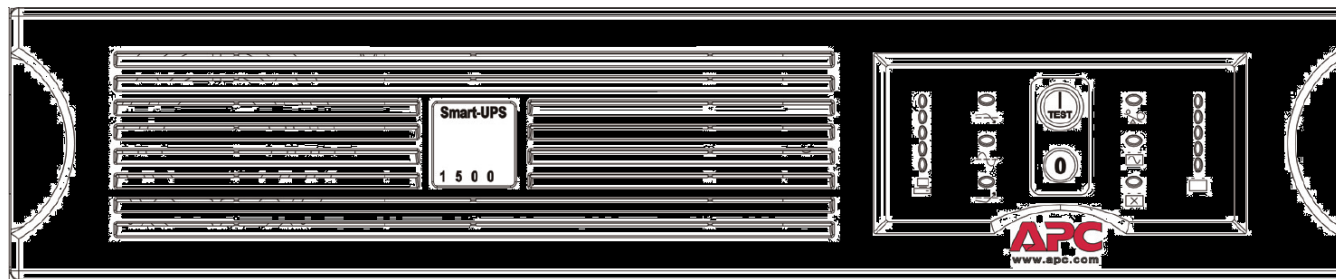

APC SMT1500RM2U

Front



A51051111991

Rear

To UPS Power Strip

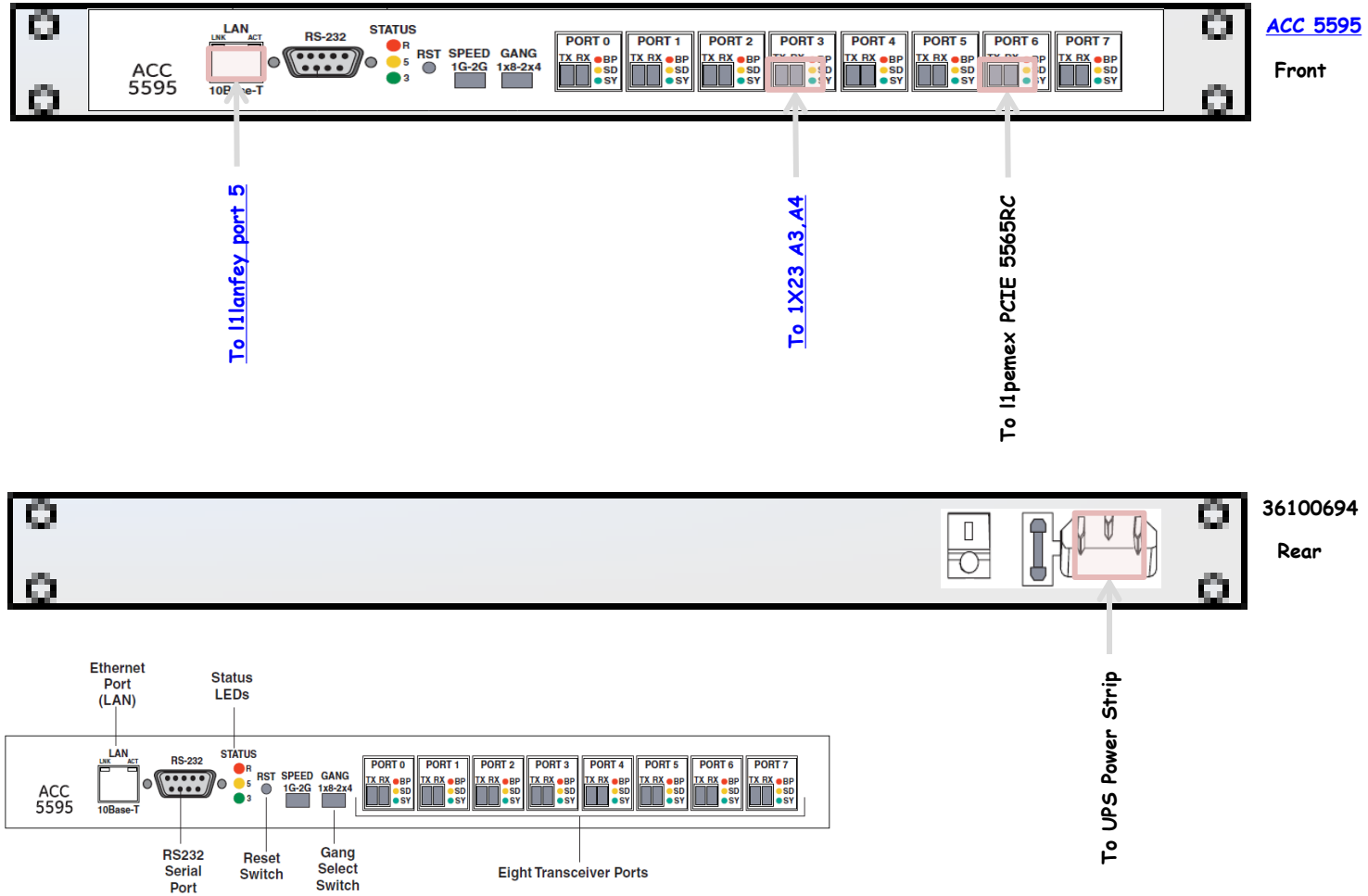

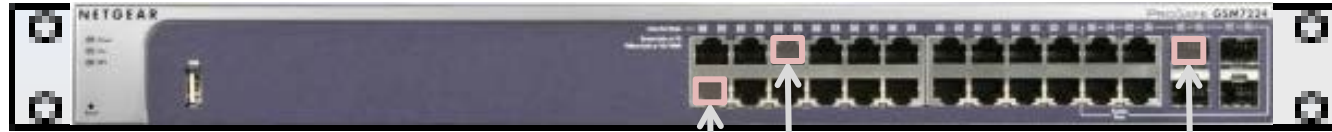

GSM7224

Front

CO:3F:0E:86:88:AC

3 - To FE LAN Port

5 - To 5595 LAN 10BaseT

21F - To 1X23 PP E3,E4



2B62045700143

Rear

To UPS Power Strip

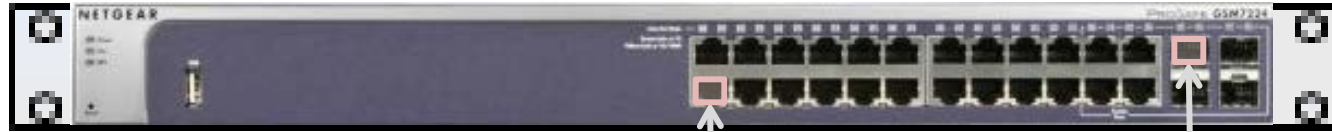

GSM7224

Front

CO:3F:0E:86:88:E0

3 - To FE NET Port

21F - To 1X23 PP B1, B2



2B62045600150

Rear

To UPS Power Strip

L1-FAC-XC1 (Planned)

Facilities <X> End Station Remote Rack Layout (LIGO-Dxxxxxxx)

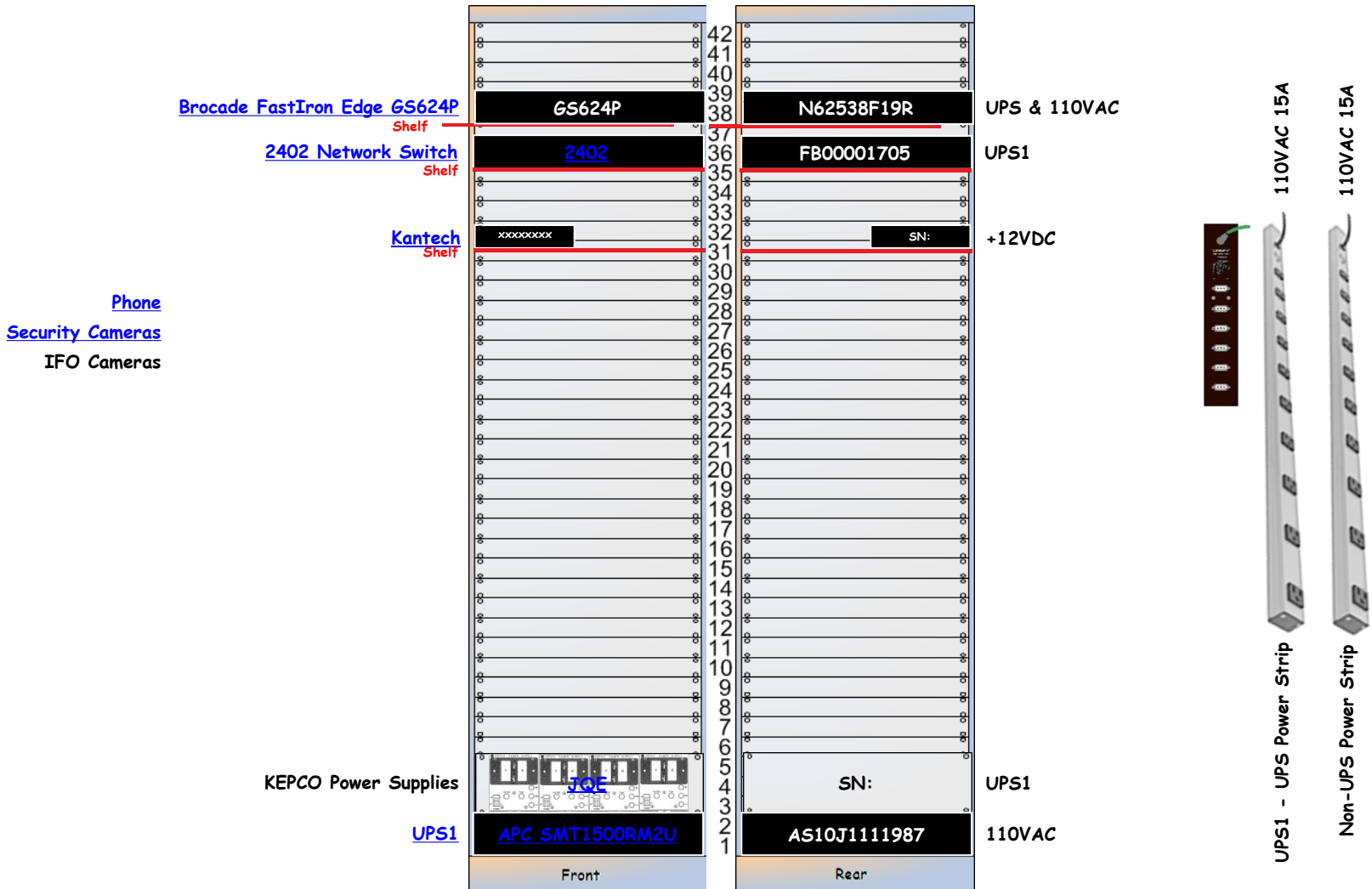

<< L1-FAC-XC1

Brocade FastIron Edge GS624P

GS624P

N62538F19R

UPS & 110VAC



GSM7224

Front

CO:3F:0E:86:88:E0

21F - To 1X23 PP B1.B2

3 - To FE NET Port

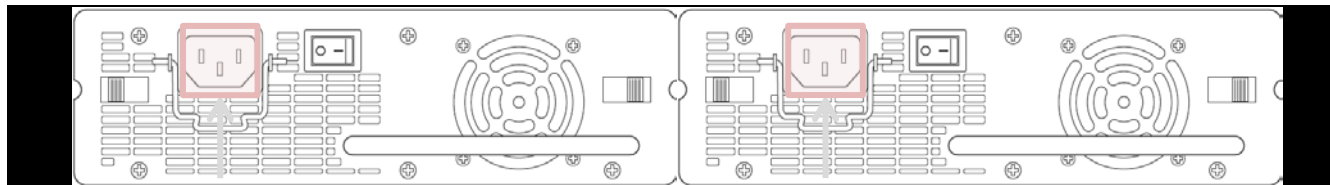

N62538F19R

Rear

To 110 Power Strip

To UPS Power Strip

<< L1-FAC-XC1

2402 Network Switch

2402

FB00001705

110VAC

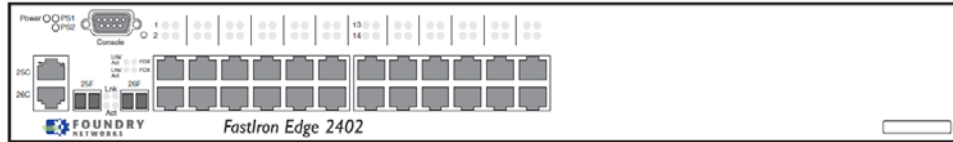

- Empty ↔ 01
- Kantech??? ↔ 02
- Empty ↔ 03
- Empty ↔ 04
- Empty ↔ 05
- Empty ↔ 06
- Empty ↔ 07
- Empty ↔ 08
- Empty ↔ 09
- Empty ↔ 10
- Empty ↔ 11
- Empty ↔ 12
- Empty ↔ 13
- To Siemens ↔ 14
- Empty ↔ 15
- Empty ↔ 16
- Empty ↔ 17
- Empty ↔ 18
- Empty ↔ 19
- Empty ↔ 20
- Empty ↔ 21
- Empty ↔ 22
- Empty ↔ 23
- Empty ↔ 24

- Empty ↔ 25C
- Empty ↔ 26C
- To Special Cable CSR1 ↔ 25F
- To 1X23 PP E1,E2 ↔ 26F

G12038
192.168.253.20

To UPS Power Strip

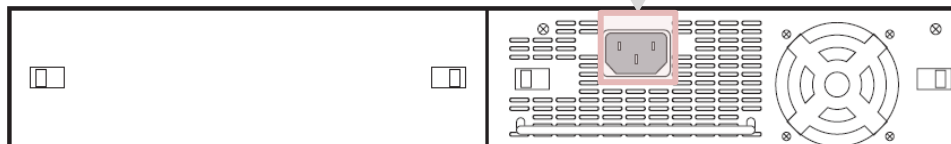

PS1

D070124 - - (Gold Box)

Gold Box

D070124

Negative LED: Red - UM13
 Negative LED: White - LL1
 Positive LED: Red - UL1
 Positive LED: White - UM14

Negative LED: Red - LM2
 Negative LED: White - LR14
 Positive LED: Red - UR14
 Positive LED: White - LM1

IN (From [Source](#))
 Orange Jacket White - UL3
 Orange Jacket Black - UM1
 Orange Jacket Green - LL3

IN (From [Source](#))
 Orange Jacket White - UR13
 Orange Jacket Black - LM2
 Orange Jacket Green - LR13

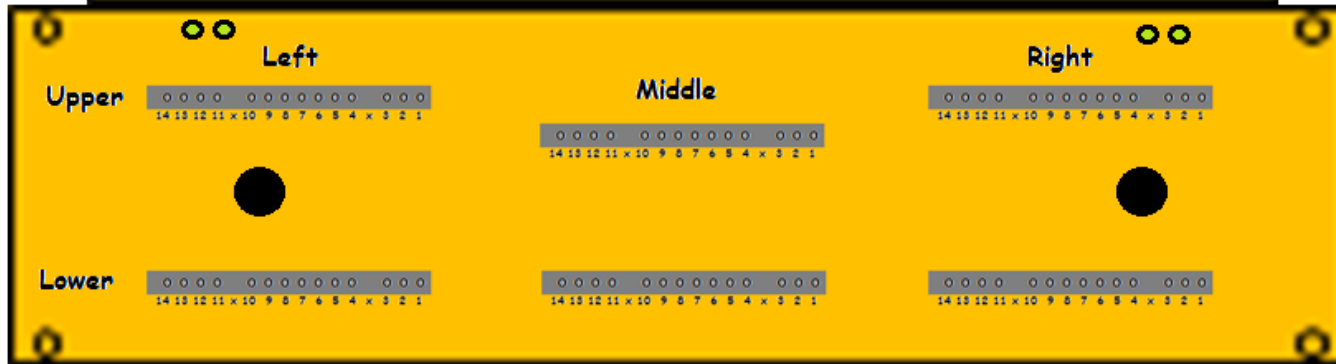

OUT-1 (To [Load](#))
 Orange Jacket White - UL3
 Orange Jacket Black - UM2
 Orange Jacket Green - LL3

OUT-1 (To [Load](#))
 Green Jacket Conductor 1 - UR12
 Green Jacket Conductor 2 - LM13
 Green Jacket Conductor 3 - (None)

1X23

Remaining 1X23 Hardware

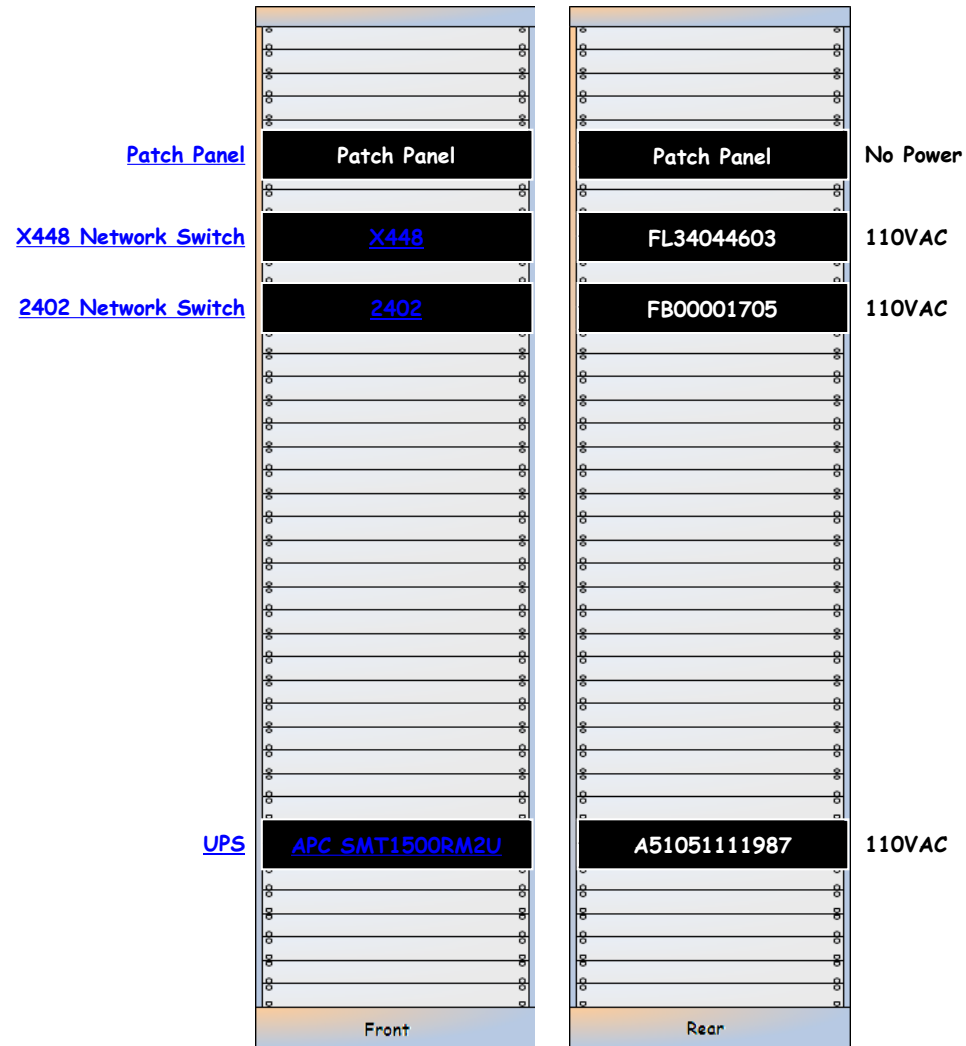

Non-UPS Power Strip 110VAC 20A

<< 1X23

Patch Panel

Patch Panel

Patch Panel

No Power

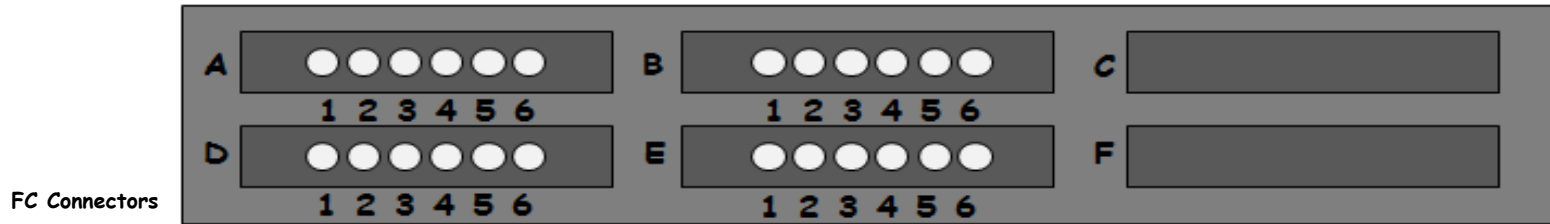

| | | | | | | | | |
|--|---|----|-----------------------------------|---|----|-------|---|----|
| Empty | ↔ | A1 | W I1netfedaqx 21F | ↔ | B1 | Empty | ↔ | C1 |
| S7711DR Opt In/Out | ↔ | A2 | Y I1netfedaqx 21F | ↔ | B2 | Empty | ↔ | C2 |
| W ACC-5595 Port 3 | ↔ | A3 | TR3030WDM Opt In | ↔ | B3 | Empty | ↔ | C3 |
| Y ACC-5595 Port 3 | ↔ | A4 | TR3030WDM Opt Out | ↔ | B4 | Empty | ↔ | C4 |
| Empty | ↔ | A5 | Empty | ↔ | B5 | Empty | ↔ | C5 |
| Empty | ↔ | A6 | VT430 Opt In/Out | ↔ | B6 | Empty | ↔ | C6 |
| Empty | ↔ | D1 | T 2402 25F | ↔ | E1 | Empty | ↔ | F1 |
| Empty | ↔ | D2 | N 2402 25F | ↔ | E2 | Empty | ↔ | F2 |
| W D070011 Fanout Input | ↔ | D3 | W I1lanfex 21F | ↔ | E3 | Empty | ↔ | F3 |
| Y D070011 Fanout Input | ↔ | D4 | Y I1lanfex 21F | ↔ | E4 | Empty | ↔ | F4 |
| W Brocade Port 1F | ↔ | D5 | Empty | ↔ | E5 | Empty | ↔ | F5 |
| Empty | ↔ | D6 | Y Brocade Port 1F | ↔ | E6 | Empty | ↔ | F6 |

FC Connectors

| | | | | | |
|-----------------------------------|---|------|--|---|------|
| W l1netfedaqx 21F | ↔ | 1-1 | Empty | ↔ | 1-2 |
| Y l1netfedaqx 21F | ↔ | 1-3 | S7711DR Opt In/Out | ↔ | 1-4 |
| TR3030WDM Opt In | ↔ | 1-5 | W ACC-5595 Port 3 | ↔ | 1-6 |
| TR3030WDM Opt Out | ↔ | 1-7 | Y ACC-5595 Port 3 | ↔ | 1-8 |
| Empty | ↔ | 1-9 | Empty | ↔ | 1-10 |
| VT430 Opt In/Out | ↔ | 1-11 | Empty | ↔ | 1-12 |
| | | | | | |
| T 2402 25F | ↔ | 2-1 | Empty | ↔ | 2-2 |
| N 2402 25F | ↔ | 2-3 | Empty | ↔ | 2-4 |
| W l1lanfex 21F | ↔ | 2-5 | W D070011 Fanout Input | ↔ | 2-6 |
| Y l1lanfex 21F | ↔ | 2-7 | Y D070011 Fanout Input | ↔ | 2-8 |
| Empty | ↔ | 2-9 | W Brocade Port 1F | ↔ | 2-10 |
| Y Brocade Port 1F | ↔ | 2-11 | Empty | ↔ | 2-12 |

<< 1X23

X448 Network Switch

X448

FL34044603

110VAC

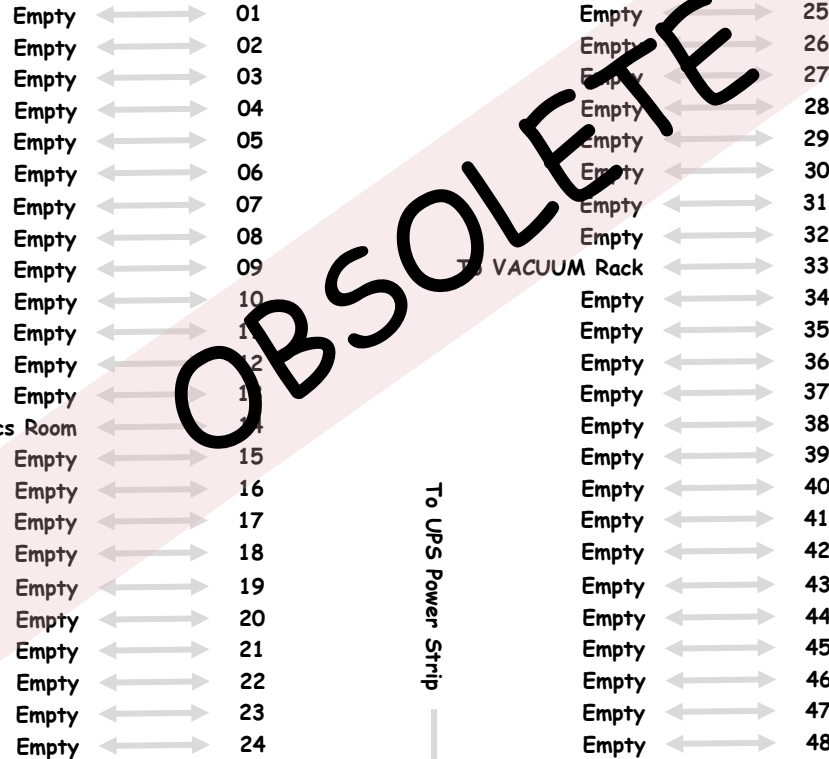
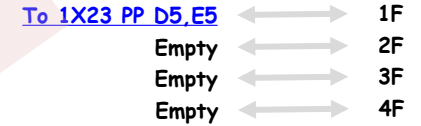
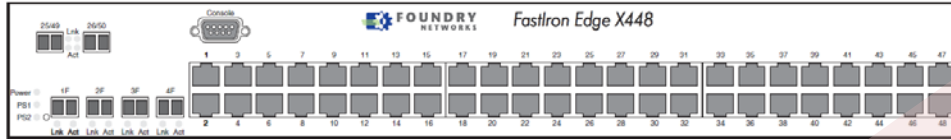

G12288
10.100.0.13

OBSOLETE

To Computer in Electronics Room

To 110VAC Strip

To UPS Power Strip

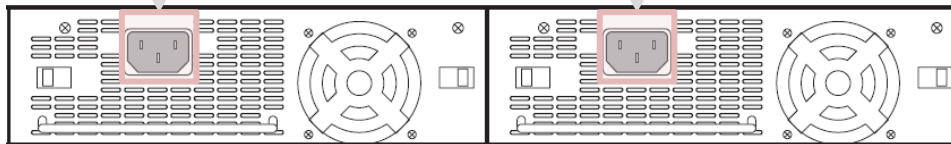

PS2

PS1

1X23 - D070443 - LH02

<< 1X23

Magnetometer: [Bartington Instruments](#)
MAG-03MC

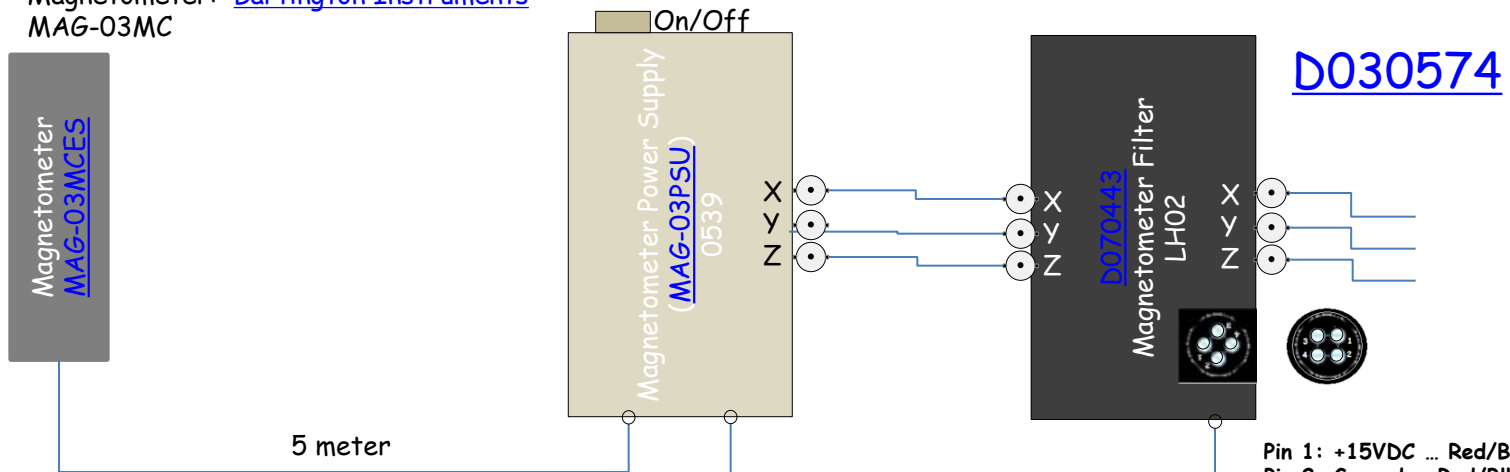

Black - G/W ... Ground
Stria - Y/W ... +12VDC

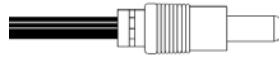

Powered from
12VDC DIN rails

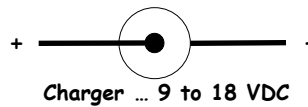

Pin 1: +15VDC ... Red/Blk RED
Pin 2: Ground ... Red/Blk BLACK
Pin 3: -15VDC ... Wht/Blk WHITE
Pin 4: Ground ... Wht/Blk BLACK

Powered from
15VDC DIN rails

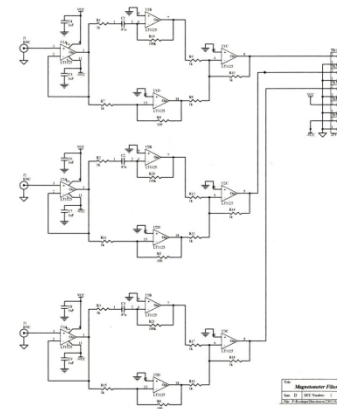

Magnetometer Filter Board

[<< 1X23](#)

Security Cameras

VT7430-2DRDT
Optical In/Out:
[To 1X23 PP B6](#)
Power: 12VDC
Output: Ch1,
Ch2, Ch3 BNCs
to Cameras

Powered from
Wall Wart from
Isolated Power

Video Master
Power Supply
Model
RT24/16500
Outputs to
Cameras 1,2,3

Note: 6 LEDs
are on.

AC Powered
from Isolated
Power

Kantech

Fiber Options
S7711DR -EST1
Optical In/Out:
[To 1X23 PP A2](#)
13.5VDC from
Wall Wart

Blue CAT5:
1=O/W and
B/W, 4=O, 7=B

Powered from
Wall Wart from
Isolated Power

Phone

TR3030WDM
GE Security
Optical In/Out:
[To 1X23 PP
B3,B4](#)
Phone: Copper to
VEA
Power: 12VDC

Powered from Wall Wart from
Tripp-Lite UPS
Model BC320
xxxxxxxxxxxxx To 6-Outlet
Power Strip in Non-isolated
wall socket

APC SMT1500RM2U

UPS

APC_SMT1500RM2U

A51051111991

110VAC

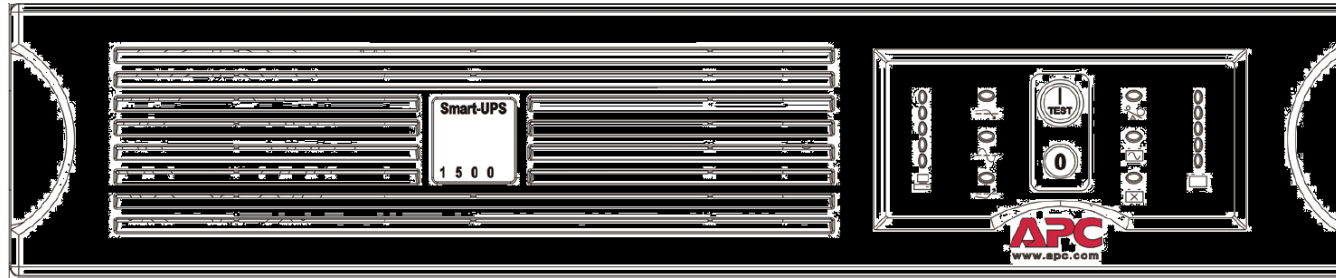

APC_SMT1500RM2U

Front

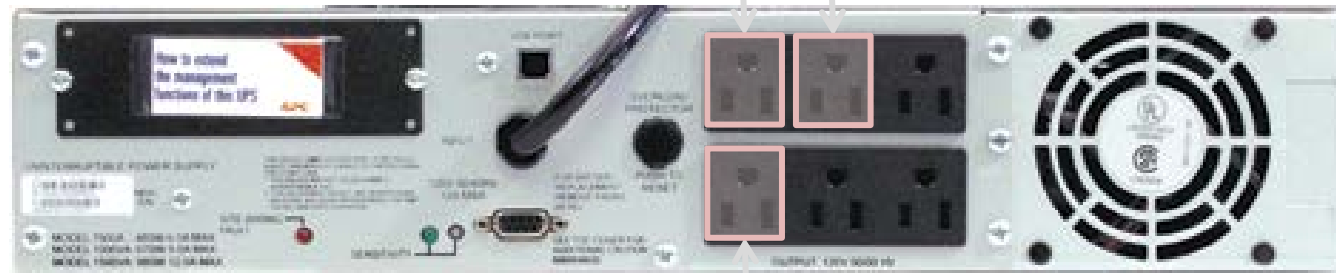

A51051111991

Rear

To 2402 PS1

To UPS Power Strip

To 8448 PS1

End Station Remote Rack Layout

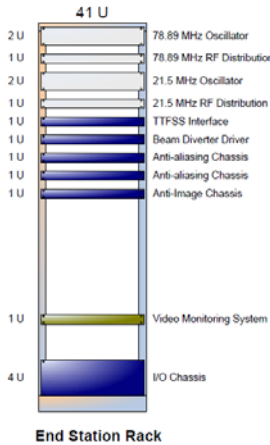

LIGO D1001459-v2

End Station Remote Rack Layout

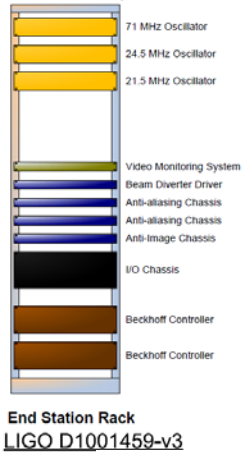

LIGO D1001459-v3

ISC End Station Remote Rack Layout

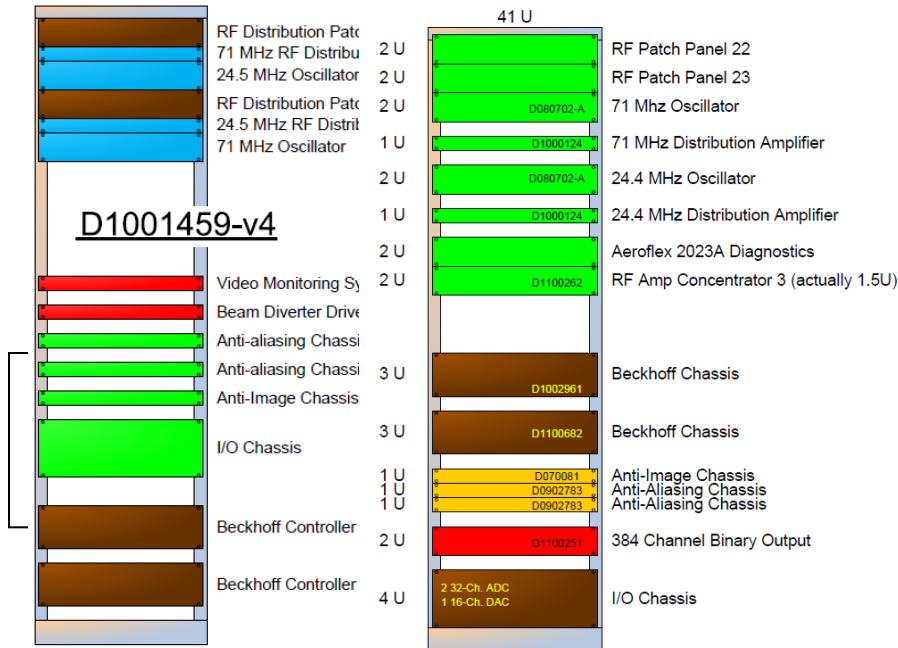

LIGO-D1001459-v8

ISC <X> End Station Rack Layout (LIGO-D1001459)

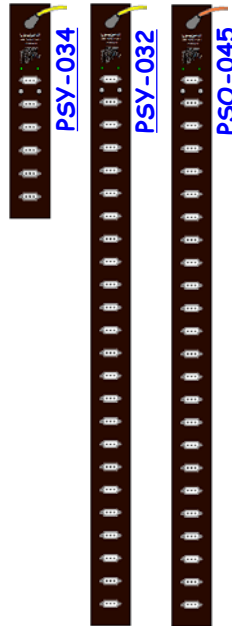
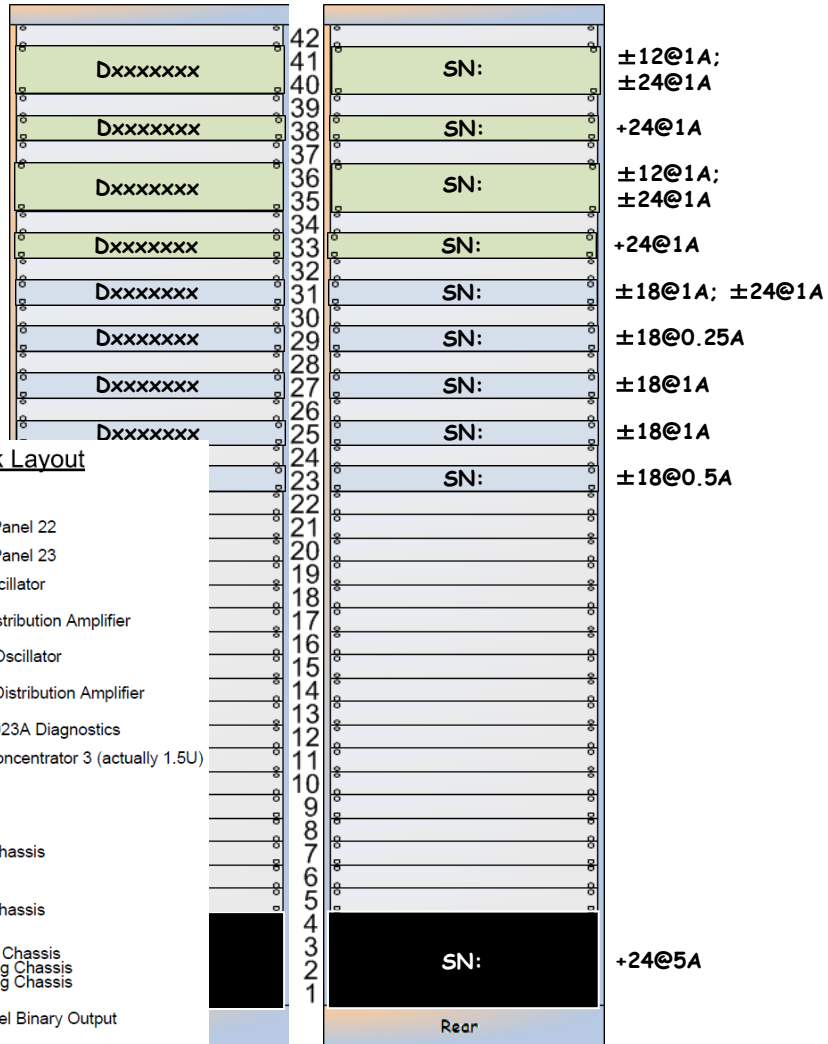

BSC CERX Racks

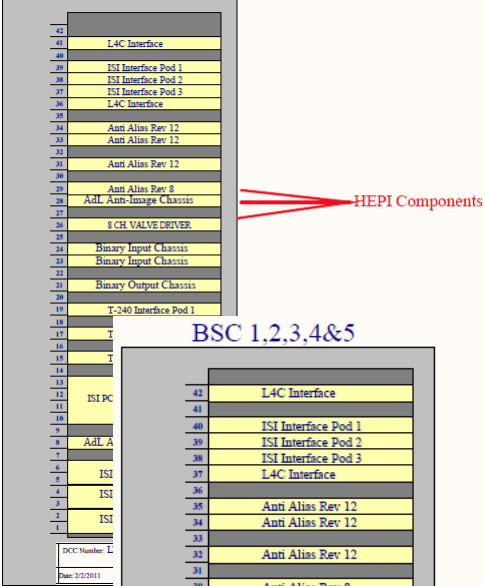

BSC 1,2,3,4&5

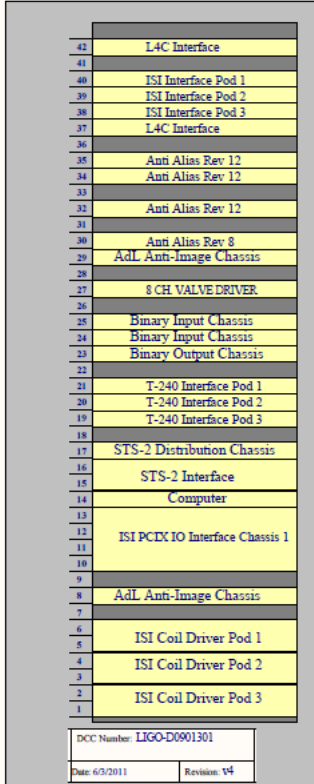

HEPI Components

HEPI Components

STS-2 Input /Distribution

Driver

Chassis

SEI BSC4 <X> Rack Layout (LIGO-D0901301)

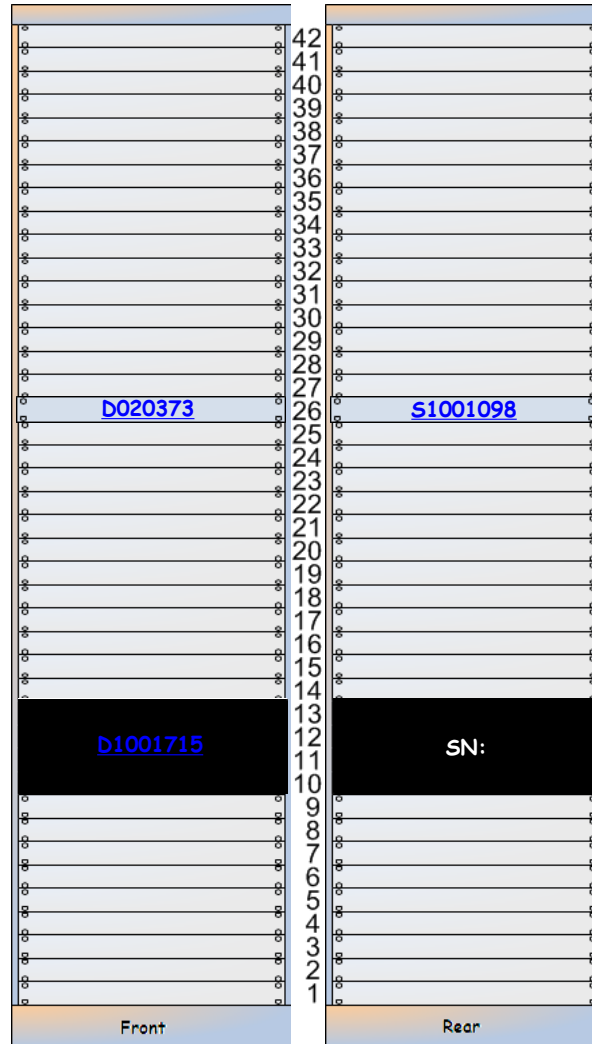

Power

+24@5,

1Y30

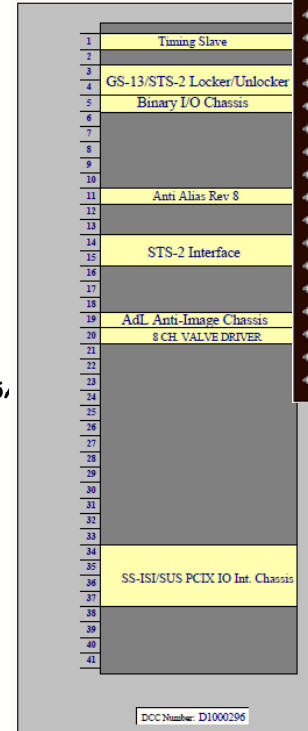

PSY-034

PSY-032

PSO-045

DCC Number: D1000296



D020373

Front

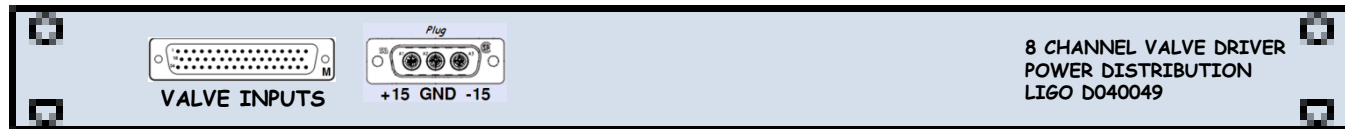
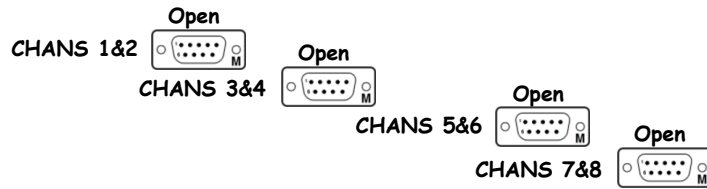

S1001098
D040049

Rear



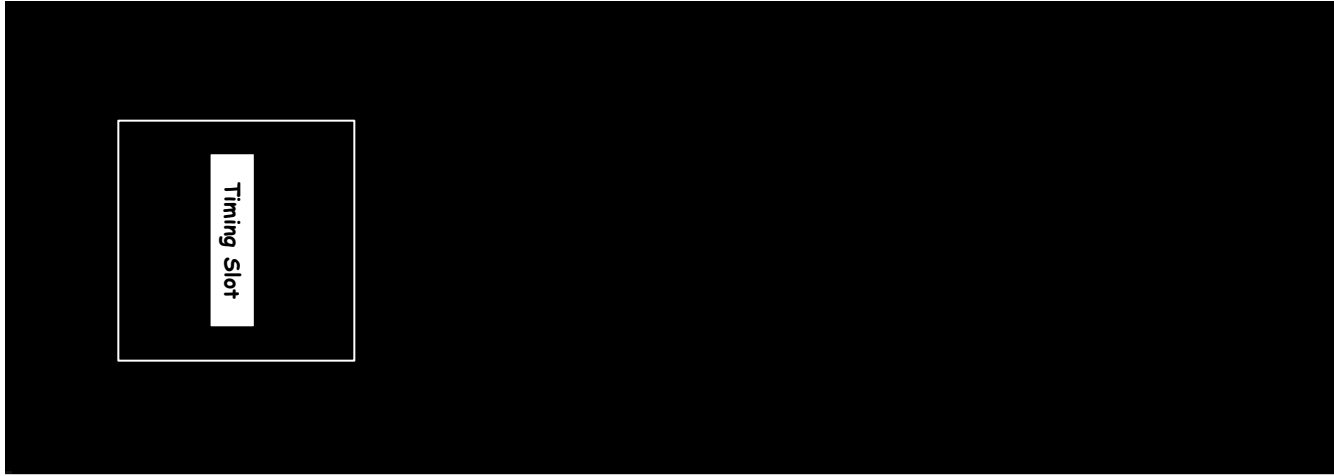

D1001715

Front

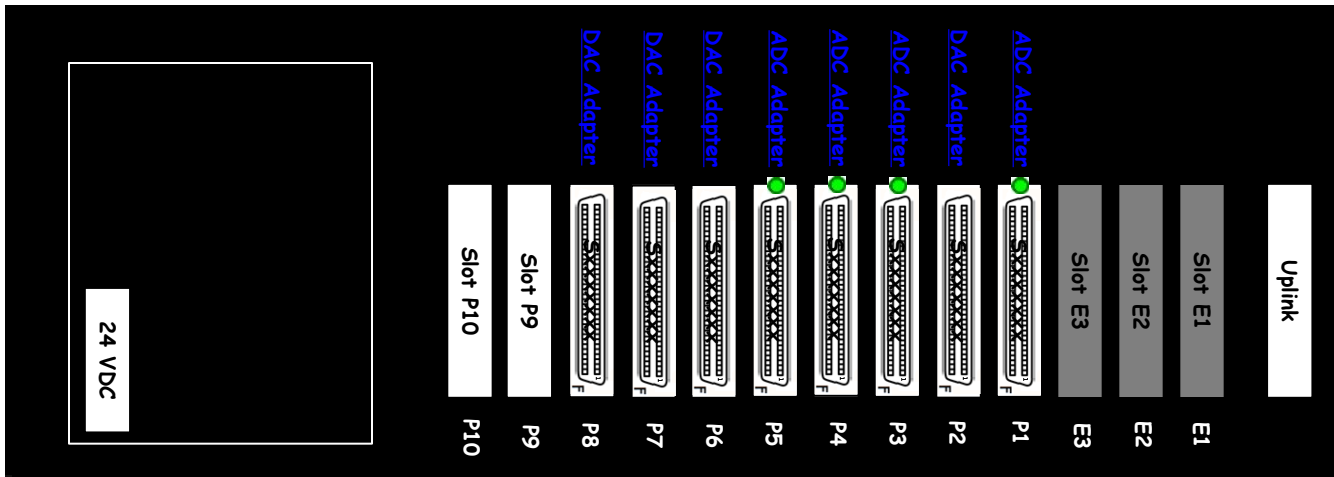

SN

Rear

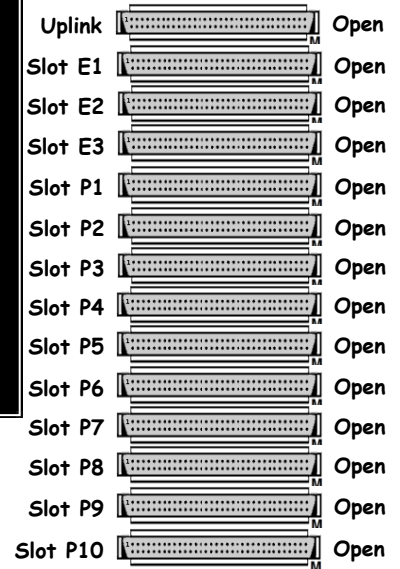

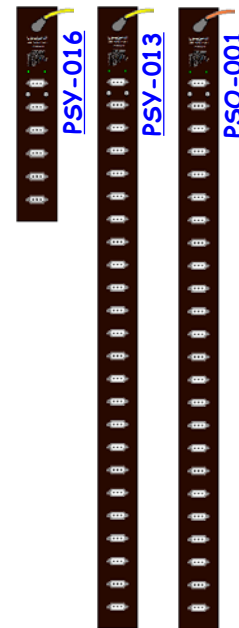
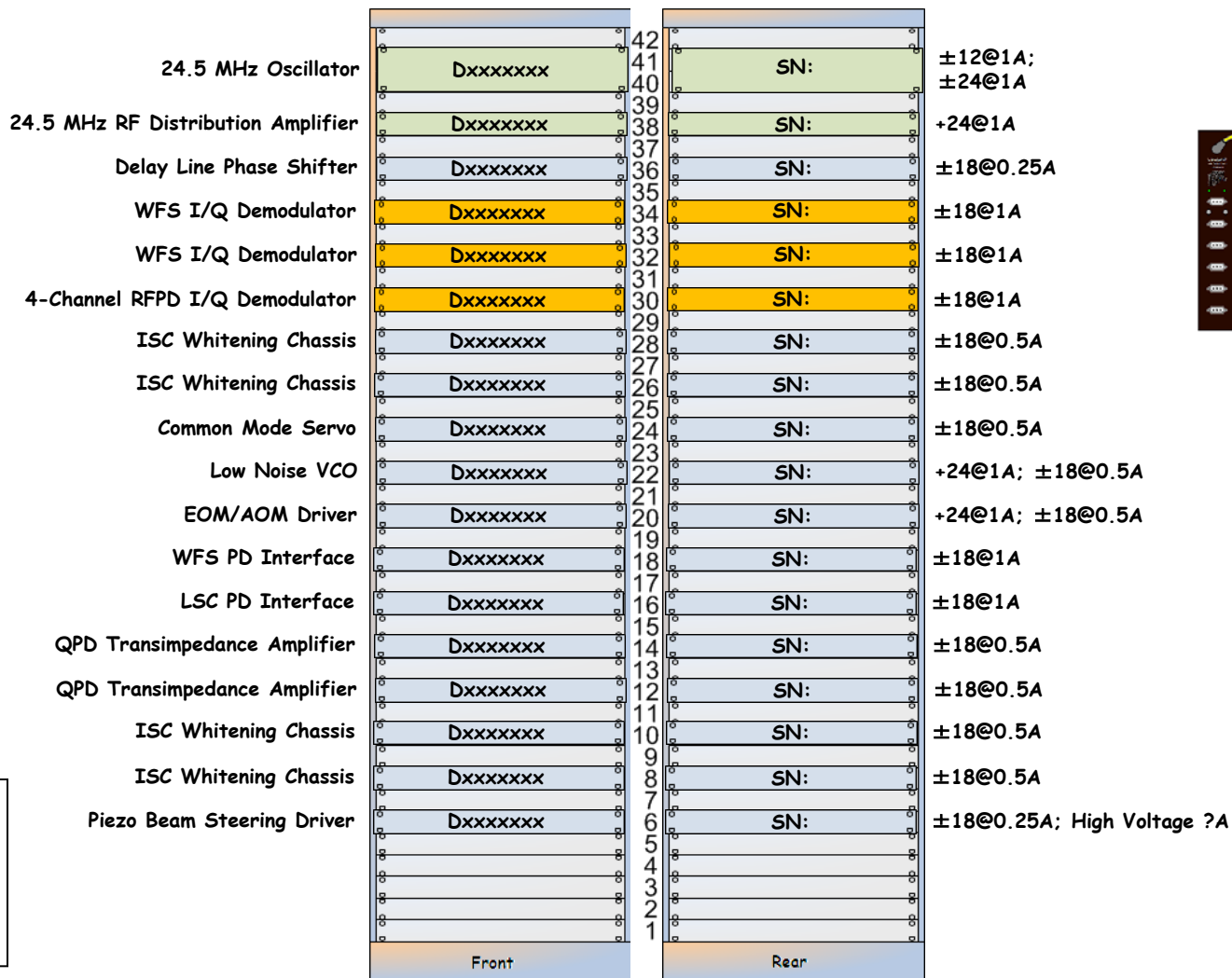

| | |
|--------------|-----|
| +12VDC | 1A |
| -12VDC | 1A |
| +18VDC | 10A |
| -18VDC | 10A |
| +24VDC | 4A |
| -24VDC | 1A |
| High Voltage | ?A |

L1-SUS-XR1

SUS <X> Rack Layout (LIGO-Dxxxxxxx)

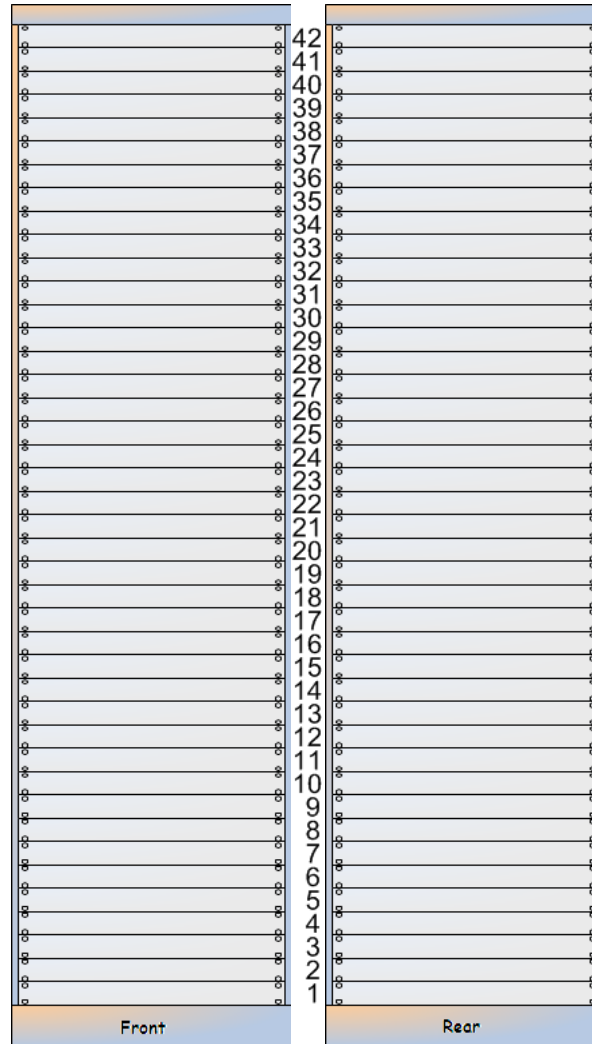

| | |
|--------|----|
| +18VDC | ?A |
| -18VDC | ?A |
| +24VDC | ?A |

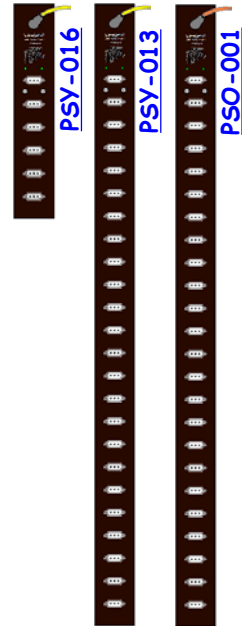

L1-TCS-XR1

TCS <X> Rack Layout ([LIGO-D1201129](#))

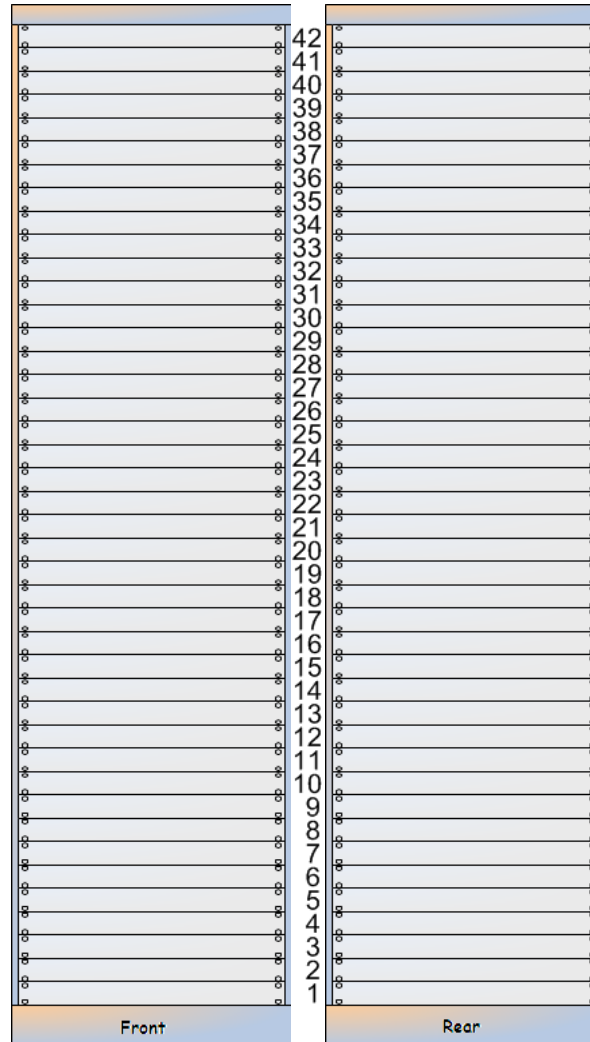

| | |
|--------|----|
| +18VDC | ?A |
| -18VDC | ?A |
| +24VDC | ?A |

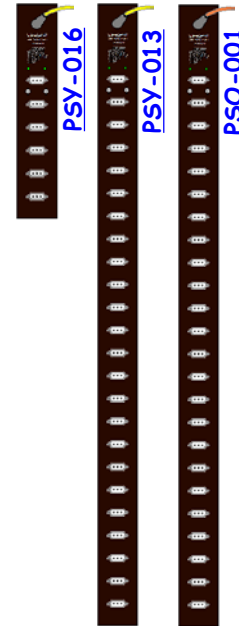

L1-VAC-XR1

VAC <X> Rack Layout (LIGO-Dxxxxxxx)

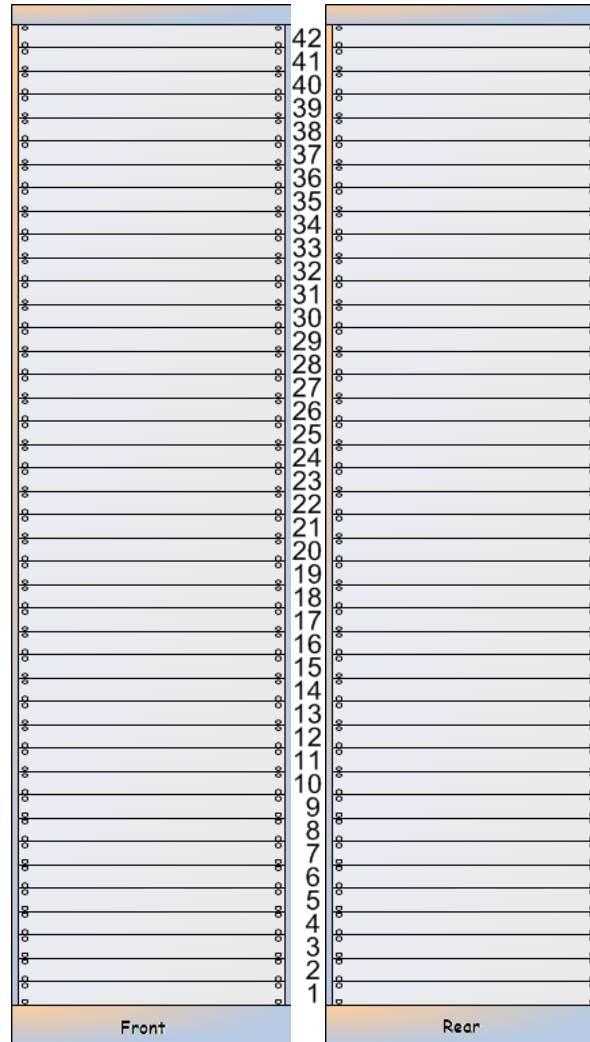

| | |
|--------|----|
| +18VDC | ?A |
| -18VDC | ?A |
| +24VDC | ?A |

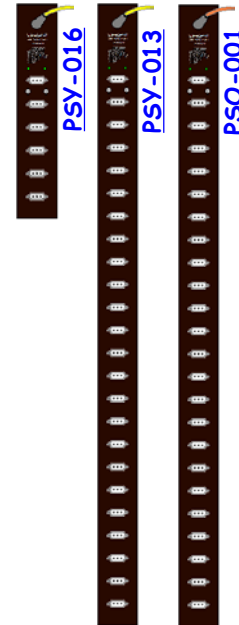

[<< LLO Map](#)

[<< LLO Racks by AREA](#)

[<< LLO CDS Components](#)

VEAY

Y-End Station Rack Layout

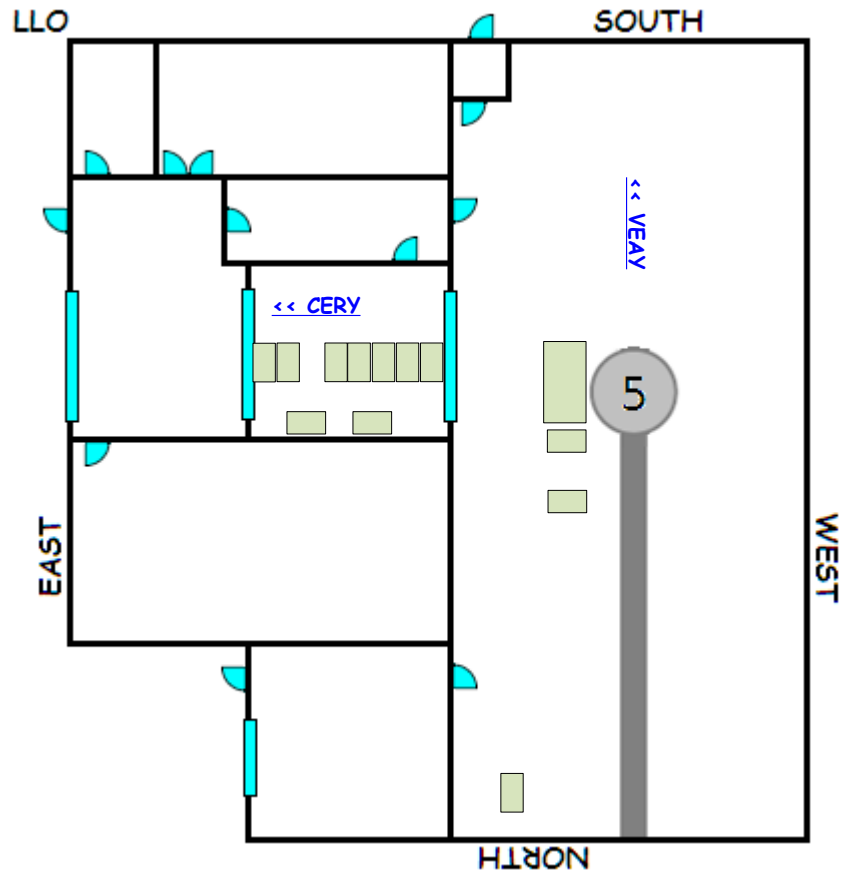

Y-End Station Rack Layout

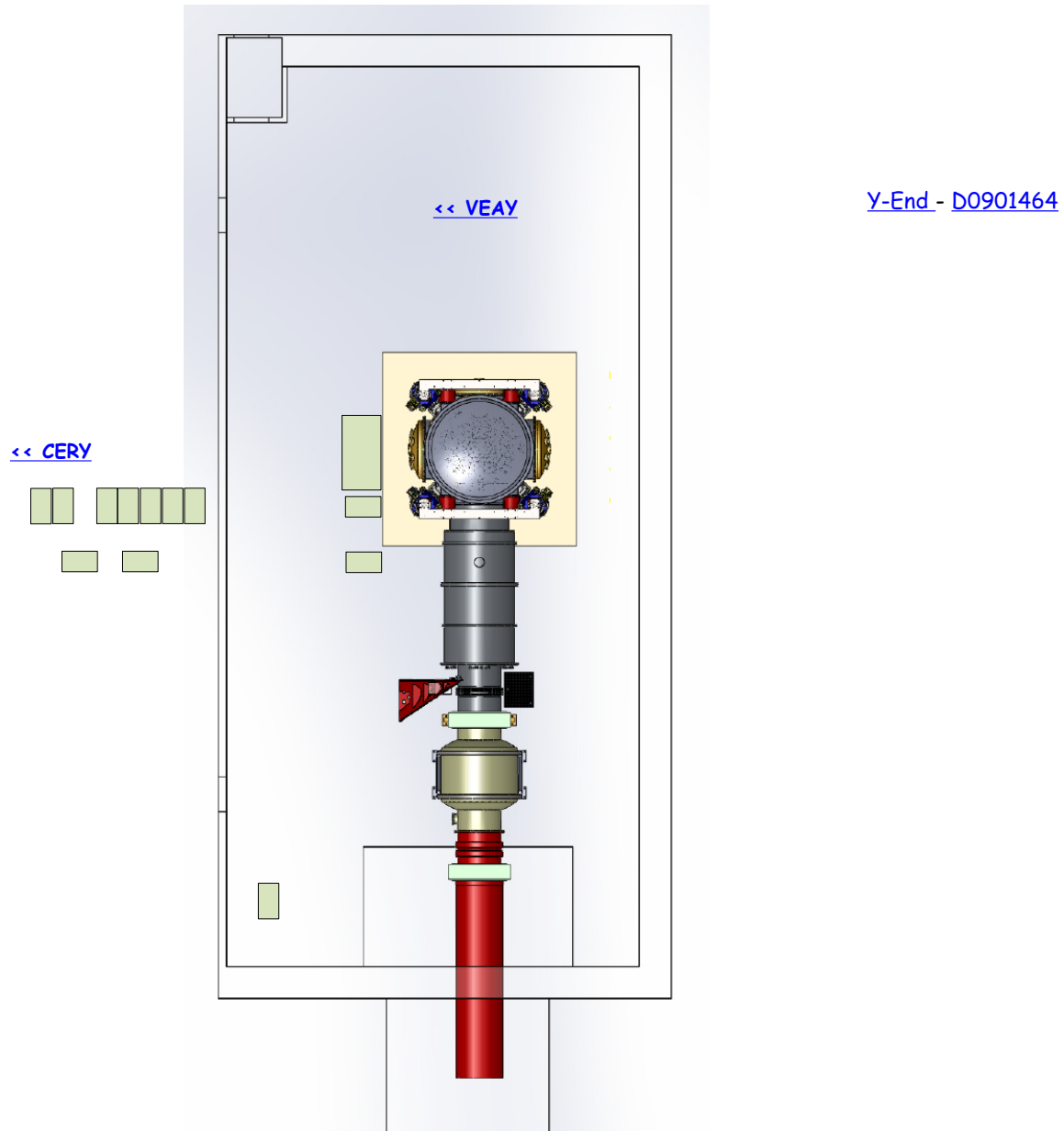

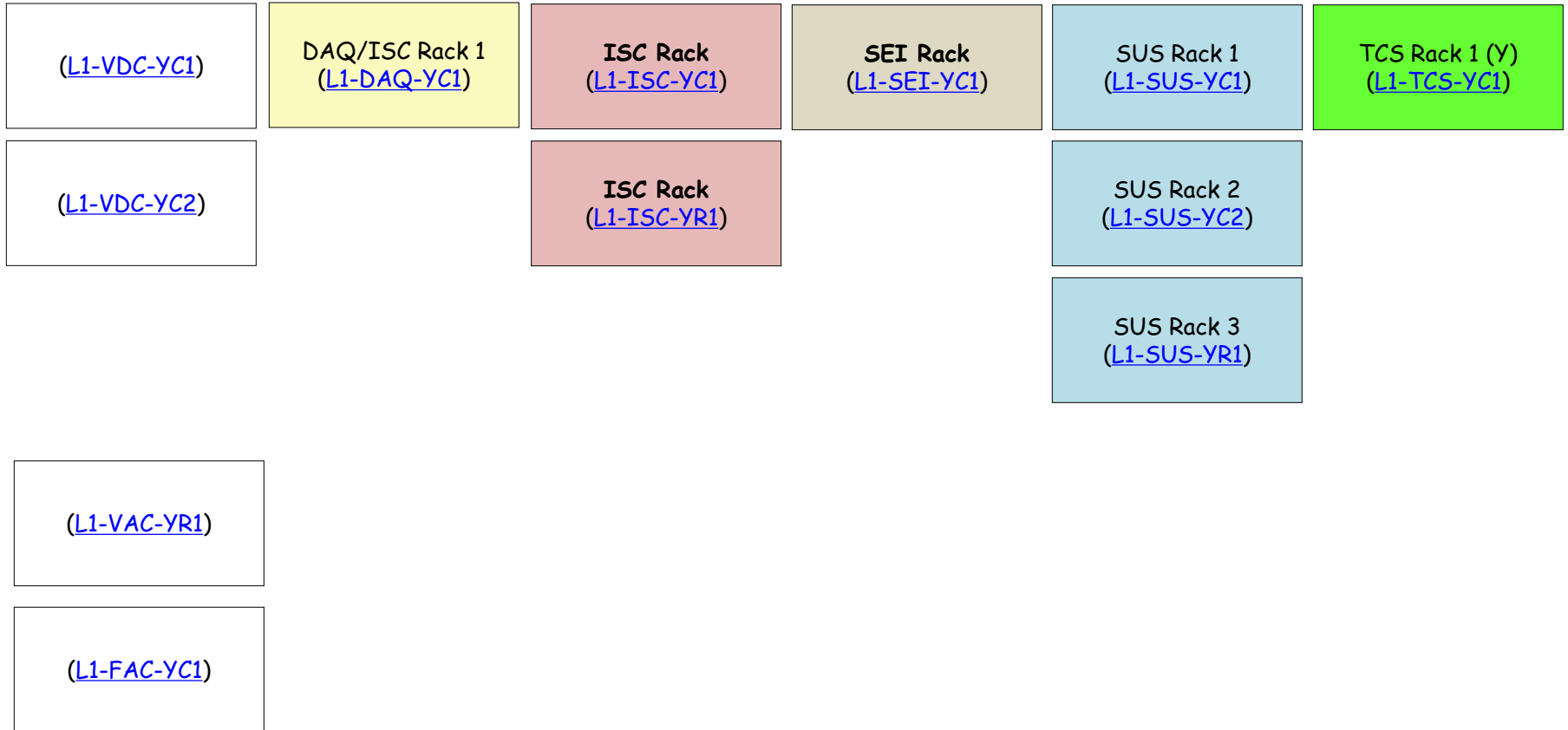

Corning WCH-06P Fiber Panel

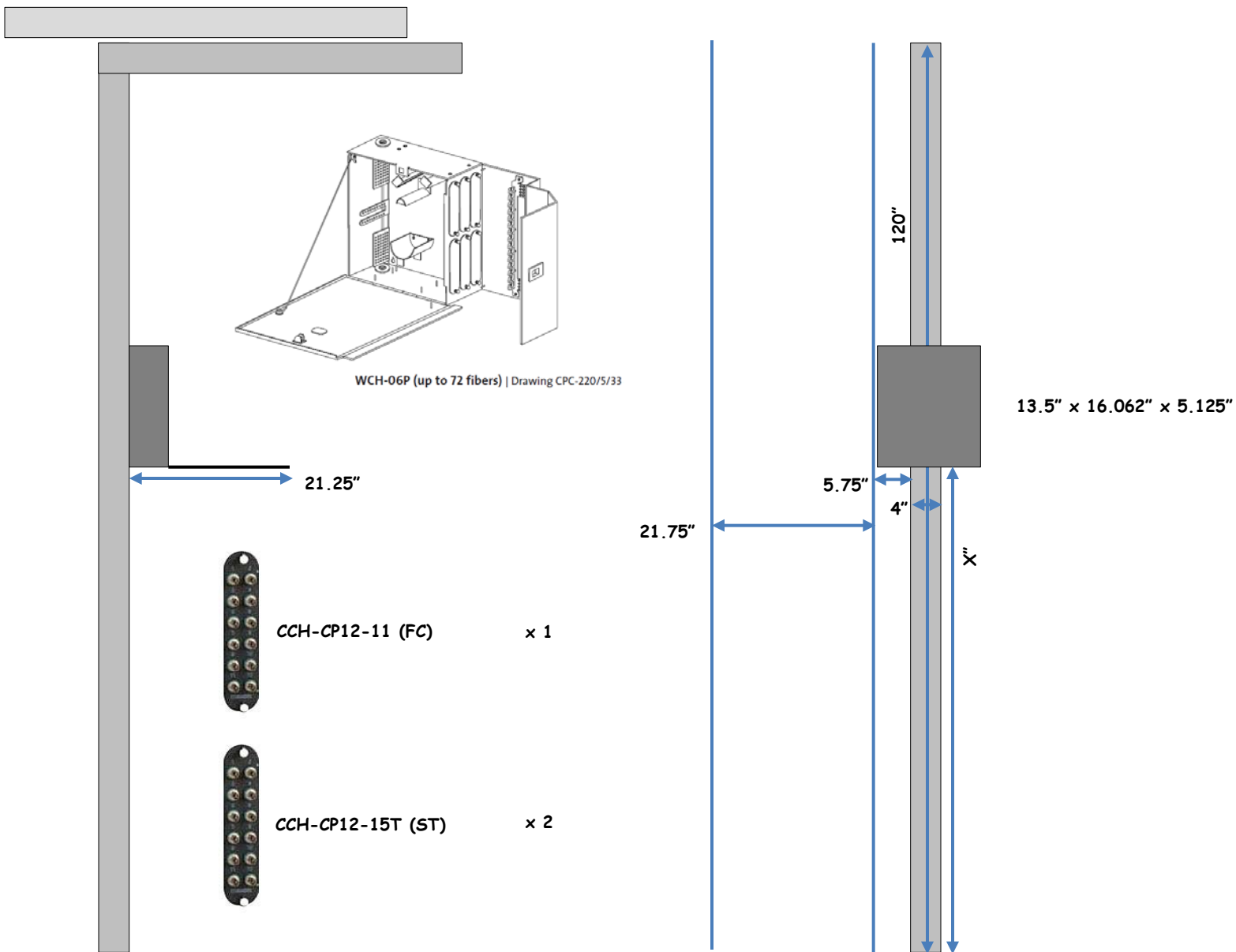

It is 65' from the L1-FAC-YC1 Rack to the knee of the waterfall in the VEAY.

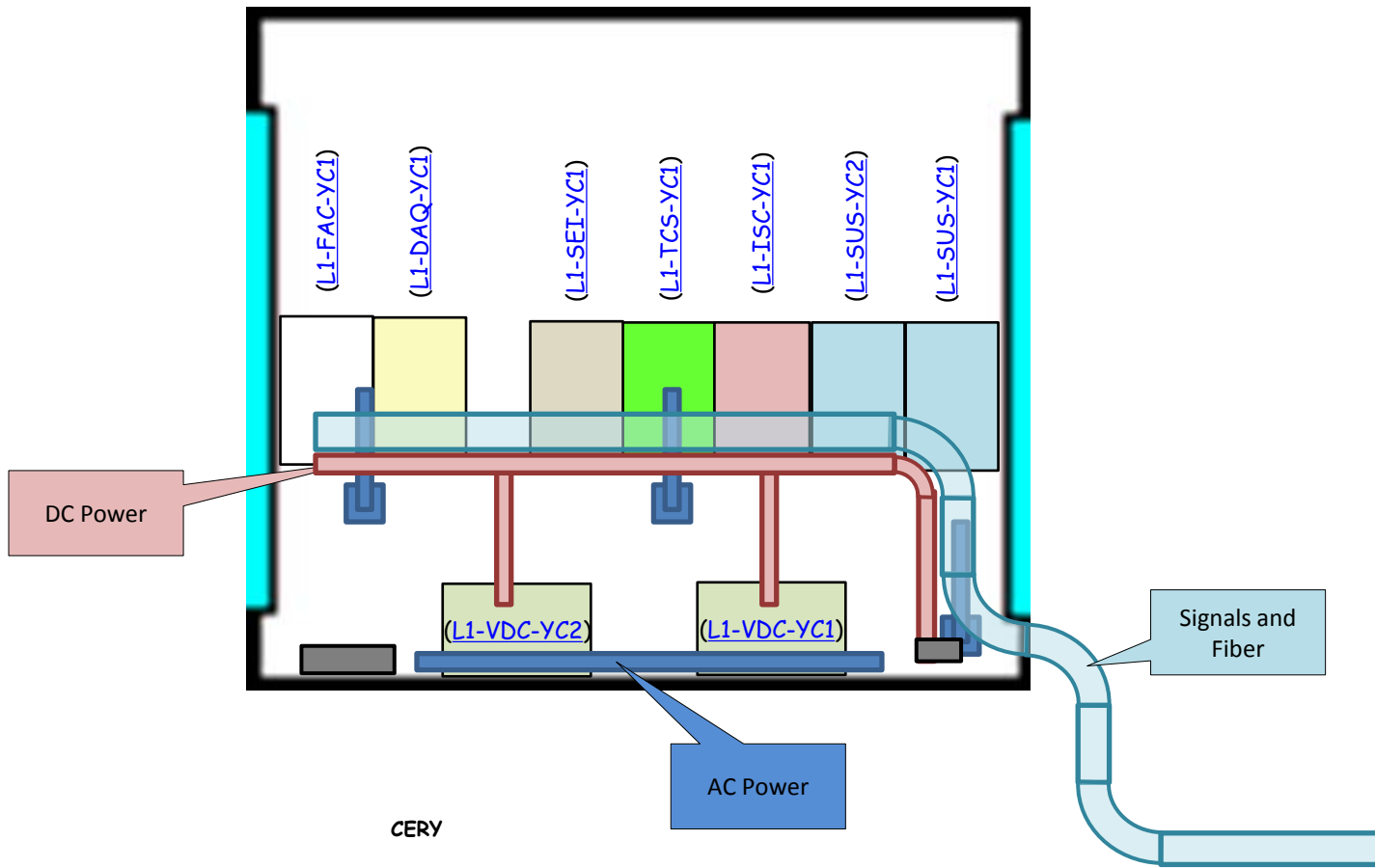

LLO Y-End Cable Tray Layout

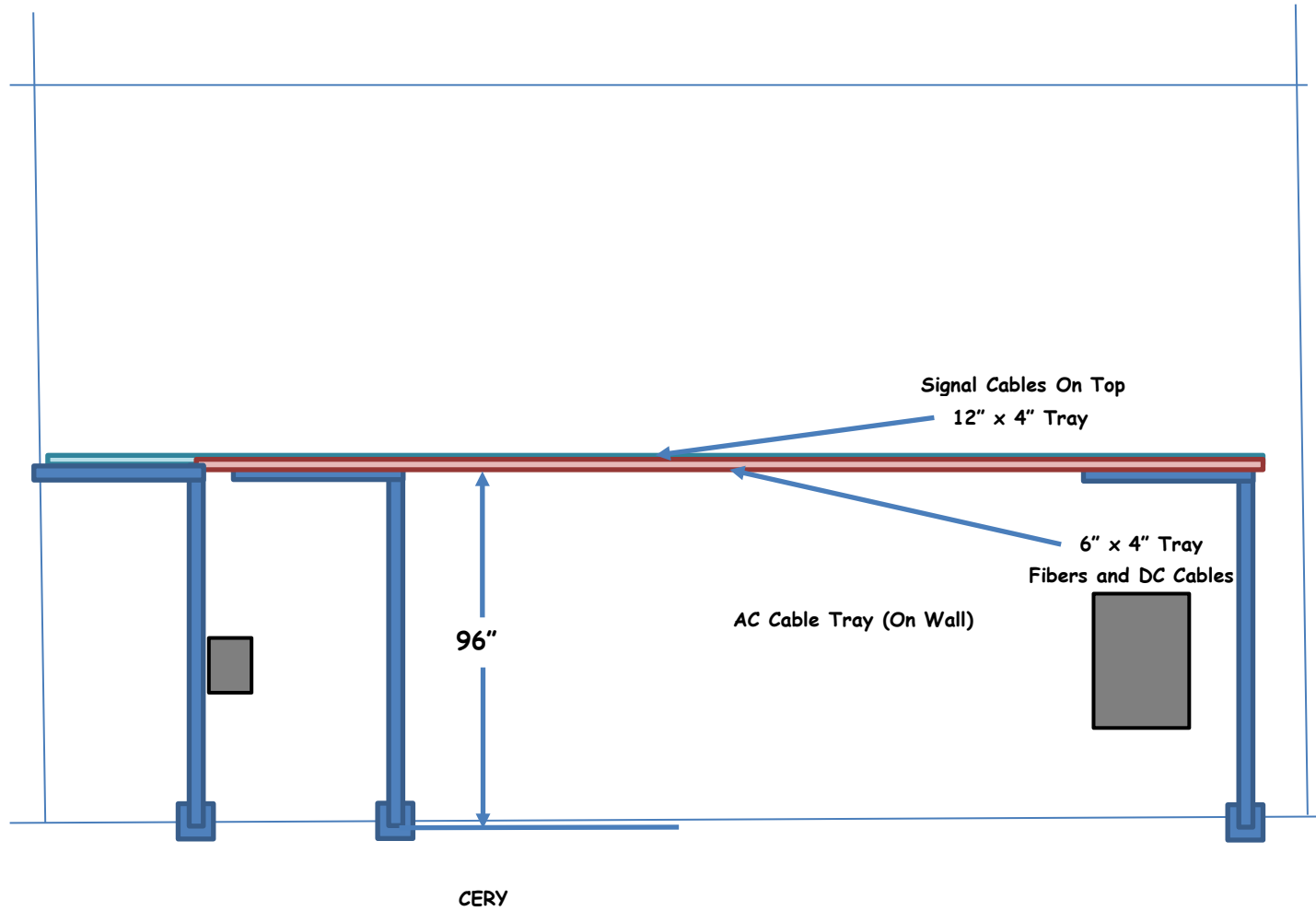

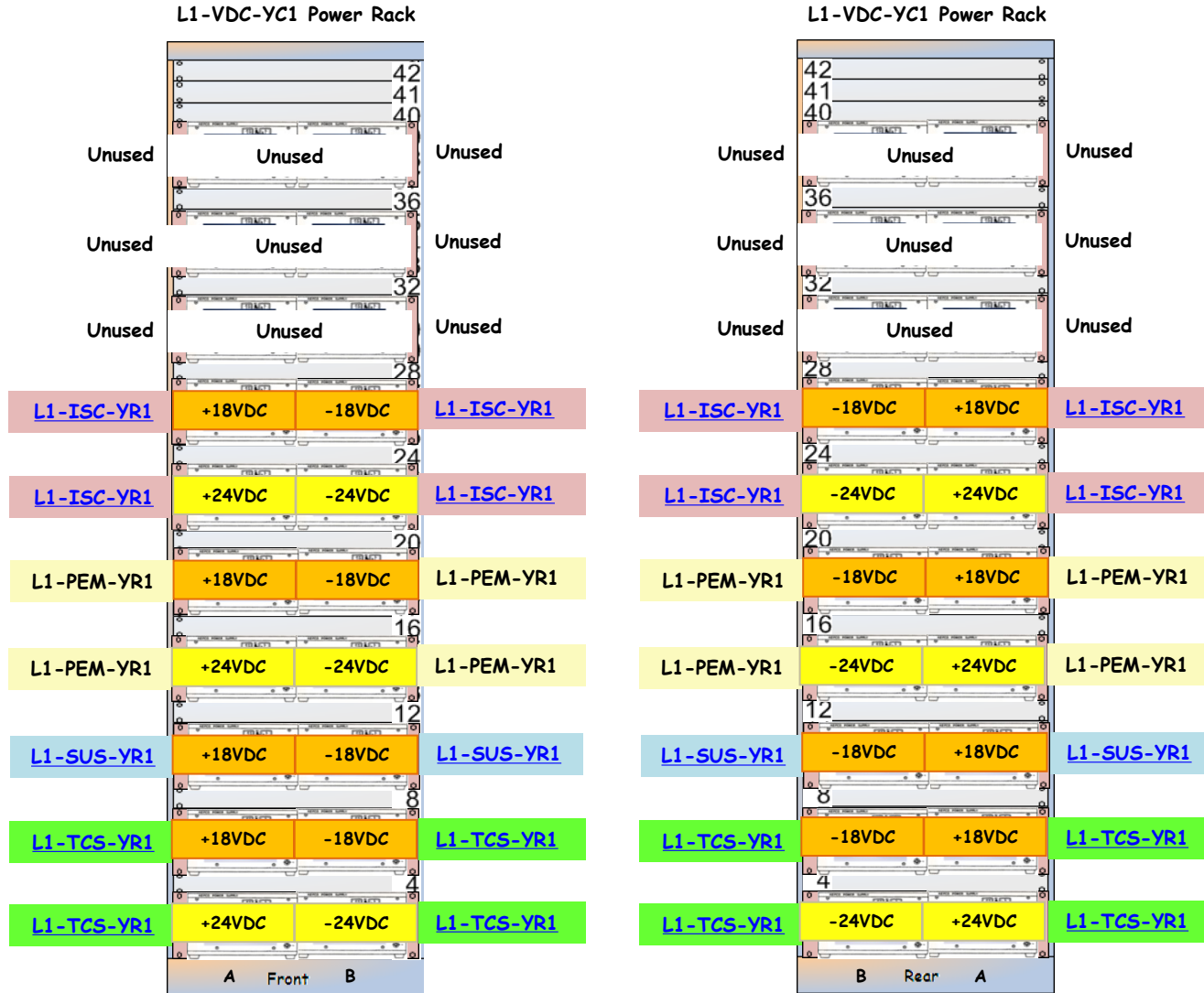

L1-VDC-YC2 Power Racks - VEAY Supplies

<< CERY Racks

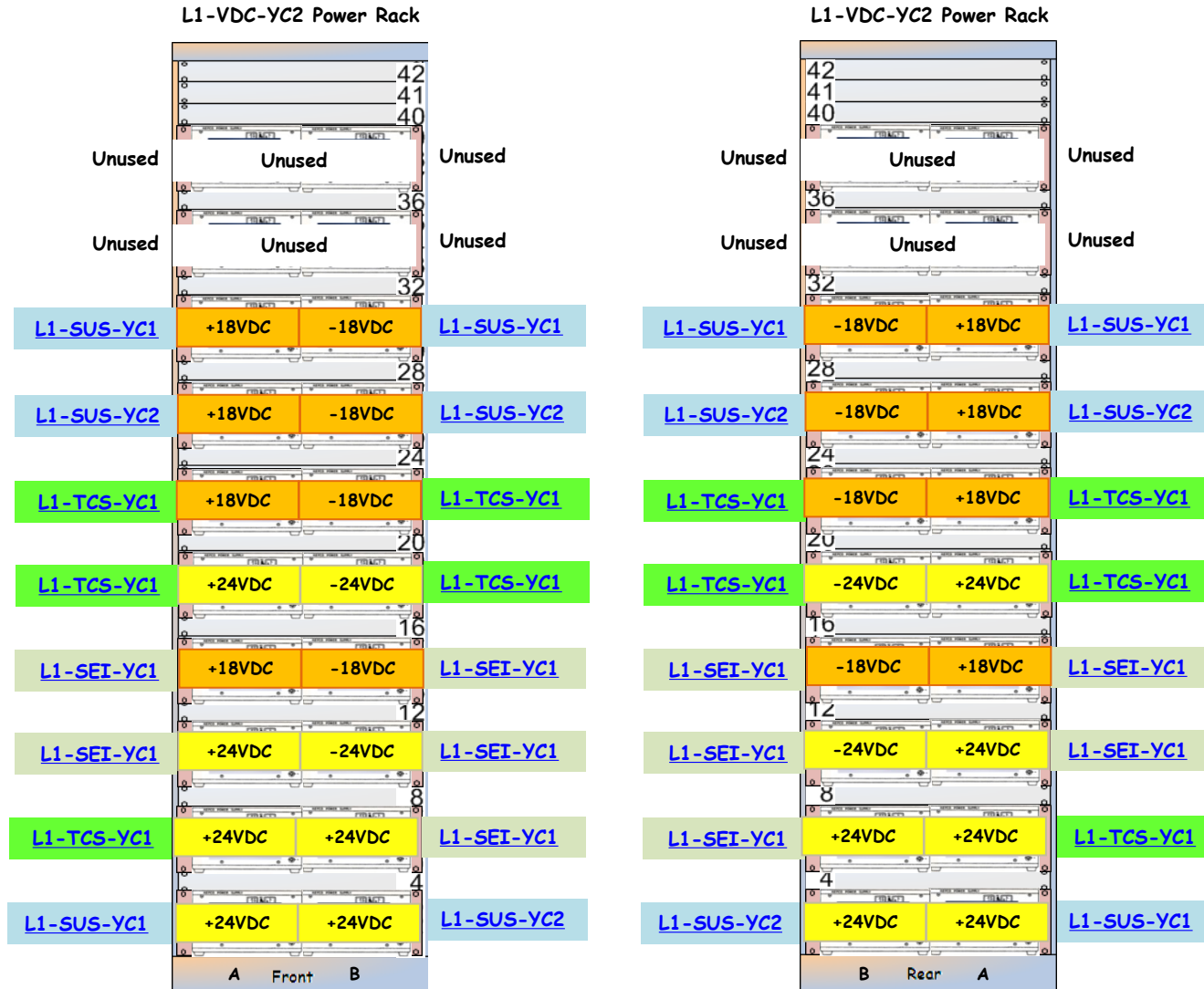

[Cable Runs >>](#)

L1-VDC-YC1 Cable Runs

<< L1-VDC-YC1

| | Power Panel | Circuit | DC Power Rack | Outlet | Plug Position | Rack U | DC Power Supply | Polarity | DC Extension Cable | Electronics Rack | DC Power Strip |
|----|-------------|---------|---------------|--------|---------------|---------------|-----------------|----------|--------------------|------------------|----------------|
| 1 | CDS-Y | | L1-VDC-YC1 | 08 | Top | U37-A (Left) | | | | | |
| 2 | CDS-Y | | L1-VDC-YC1 | 08 | Bottom | U37-B (Right) | | | | | |
| 3 | CDS-Y | | L1-VDC-YC1 | 02 | Top | U33-A (Left) | | | | | |
| 4 | CDS-Y | | L1-VDC-YC1 | 02 | Bottom | U33-B (Right) | | | | | |
| 5 | CDS-Y | | L1-VDC-YC1 | 09 | Top | U29-A (Left) | | | | | |
| 6 | CDS-Y | | L1-VDC-YC1 | 09 | Bottom | U29-B (Right) | | | | | |
| 7 | CDS-Y | | L1-VDC-YC1 | 03 | Top | U25-A (Left) | | Plus | PTO-046 | L1-ISC-YR1 | PSO-046 |
| 8 | CDS-Y | | L1-VDC-YC1 | 03 | Bottom | U25-B (Right) | | Minus | PTO-046 | L1-ISC-YR1 | PSO-046 |
| 9 | CDS-Y | | L1-VDC-YC1 | 10 | Top | U21-A (Left) | | Plus | PTY-037 | L1-ISC-YR1 | PSY-037 |
| 10 | CDS-Y | | L1-VDC-YC1 | 10 | Bottom | U21-B (Right) | | Minus | PTY-037 | L1-ISC-YR1 | PSY-037 |
| 11 | CDS-Y | | L1-VDC-YC1 | 04 | Top | U17-A (Left) | | Plus | PTO-047 | L1-PEM-YR1 | PSO-047 |
| 12 | CDS-Y | | L1-VDC-YC1 | 04 | Bottom | U17-B (Right) | | Minus | PTO-047 | L1-PEM-YR1 | PSO-047 |
| 13 | CDS-Y | | L1-VDC-YC1 | 11 | Top | U13-A (Left) | | Plus | PTY-038 | L1-PEM-YR1 | PSY-038 |
| 14 | CDS-Y | | L1-VDC-YC1 | 11 | Bottom | U13-B (Right) | | Minus | PTY-038 | L1-PEM-YR1 | PSY-038 |
| 15 | CDS-Y | | L1-VDC-YC1 | 05 | Top | U09-A (Left) | | Plus | PTO-048 | L1-SUS-YR1 | PSO-048 |
| 16 | CDS-Y | | L1-VDC-YC1 | 05 | Bottom | U09-B (Right) | | Minus | PTO-048 | L1-SUS-YR1 | PSO-048 |
| 17 | CDS-Y | | L1-VDC-YC1 | 12 | Top | U05-A (Left) | | Plus | PTO-049 | L1-TCS-YR1 | PSO-049 |
| 18 | CDS-Y | | L1-VDC-YC1 | 12 | Bottom | U05-B (Right) | | Minus | PTO-049 | L1-TCS-YR1 | PSO-049 |
| 19 | CDS-Y | | L1-VDC-YC1 | 06 | Top | U01-A (Left) | | Plus | PTY-039 | L1-TCS-YR1 | PSY-039 |
| 20 | CDS-Y | | L1-VDC-YC1 | 06 | Bottom | U01-B (Right) | | Minus | PTY-039 | L1-TCS-YR1 | PSY-039 |
| | | | | | | | | | | | |

L1-VDC-YC2 Cable Runs

<< L1-VDC-YC2

| | Power Panel | Circuit | DC Power Rack | Outlet | Plug Position | Rack U | DC Power Supply | Polarity | DC Extension Cable | Electronics Rack | DC Power Strip |
|----|-------------|---------|---------------|--------|---------------|---------------|-----------------|----------|--------------------|------------------|----------------|
| 1 | CDS-Y | | L1-VDC-YC2 | 08 | Top | U37-A (Left) | | | | | |
| 2 | CDS-Y | | L1-VDC-YC2 | 08 | Bottom | U37-B (Right) | | | | | |
| 3 | CDS-Y | | L1-VDC-YC2 | 02 | Top | U33-A (Left) | | | | | |
| 4 | CDS-Y | | L1-VDC-YC2 | 02 | Bottom | U33-B (Right) | | | | | |
| 5 | CDS-Y | | L1-VDC-YC2 | 09 | Top | U29-A (Left) | | Plus | PTO-050 | L1-SUS-YC1 | PSO-050 |
| 6 | CDS-Y | | L1-VDC-YC2 | 09 | Bottom | U29-B (Right) | | Minus | PTO-050 | L1-SUS-YC1 | PSO-050 |
| 7 | CDS-Y | | L1-VDC-YC2 | 03 | Top | U25-A (Left) | | Plus | PTO-051 | L1-SUS-YC2 | PSO-051 |
| 8 | CDS-Y | | L1-VDC-YC2 | 03 | Bottom | U25-B (Right) | | Minus | PTO-051 | L1-SUS-YC2 | PSO-051 |
| 9 | CDS-Y | | L1-VDC-YC2 | 10 | Top | U21-A (Left) | | Plus | PTO-052 | L1-TCS-YC1 | PSO-052 |
| 10 | CDS-Y | | L1-VDC-YC2 | 10 | Bottom | U21-B (Right) | | Minus | PTO-052 | L1-TCS-YC1 | PSO-052 |
| 11 | CDS-Y | | L1-VDC-YC2 | 04 | Top | U17-A (Left) | | Plus | PTY-040 | L1-TCS-YC1 | PSY-040 |
| 12 | CDS-Y | | L1-VDC-YC2 | 04 | Bottom | U17-B (Right) | | Minus | PTY-040 | L1-TCS-YC1 | PSY-040 |
| 13 | CDS-Y | | L1-VDC-YC2 | 11 | Top | U13-A (Left) | | Plus | PTO-053 | L1-SEI-YC1 | PSO-053 |
| 14 | CDS-Y | | L1-VDC-YC2 | 11 | Bottom | U13-B (Right) | | Minus | PTO-053 | L1-SEI-YC1 | PSO-053 |
| 15 | CDS-Y | | L1-VDC-YC2 | 05 | Top | U09-A (Left) | | Plus | PTY-041 | L1-SEI-YC1 | PSY-041 |
| 16 | CDS-Y | | L1-VDC-YC2 | 05 | Bottom | U09-B (Right) | | Minus | PTY-041 | L1-SEI-YC1 | PSY-041 |
| 17 | CDS-Y | | L1-VDC-YC2 | 12 | Top | U05-A (Left) | | Plus | PTY-042 | L1-TCS-YC1 | PSY-042 |
| 18 | CDS-Y | | L1-VDC-YC2 | 12 | Bottom | U05-B (Right) | | Plus | PTY-043 | L1-SEI-YC1 | PSY-043 |
| 19 | CDS-Y | | L1-VDC-YC2 | 06 | Top | U01-A (Left) | | Plus | PTY-044 | L1-SUS-YC1 | PSY-044 |
| 20 | CDS-Y | | L1-VDC-YC2 | 06 | Bottom | U01-B (Right) | | Plus | PTY-045 | L1-SUS-YC2 | PSY-045 |

L1-PEM-YC1 (Temporary)

<< CERY Racks

PEM/ISC <Y> End Station Remote Rack Layout (LIGO-Dxxxxxxx)

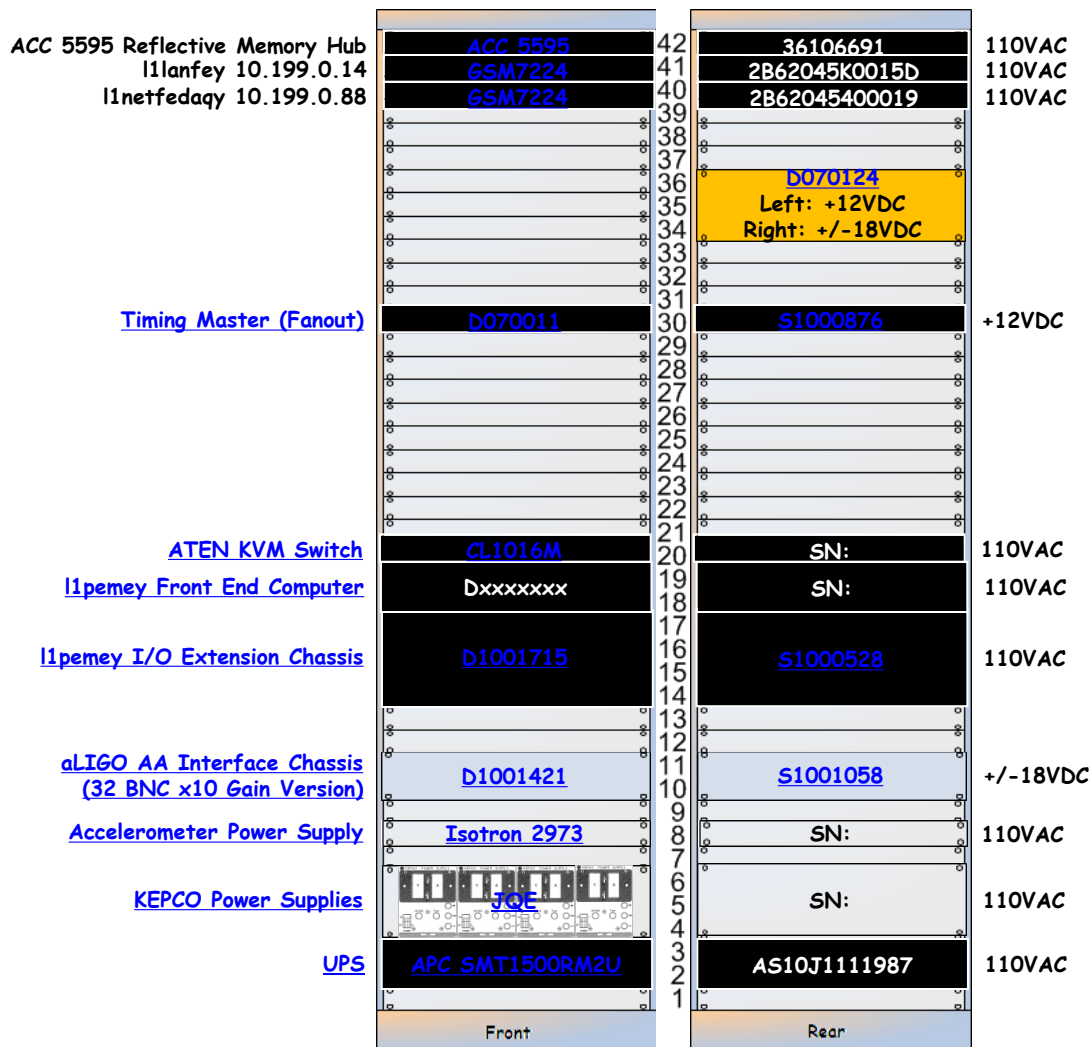

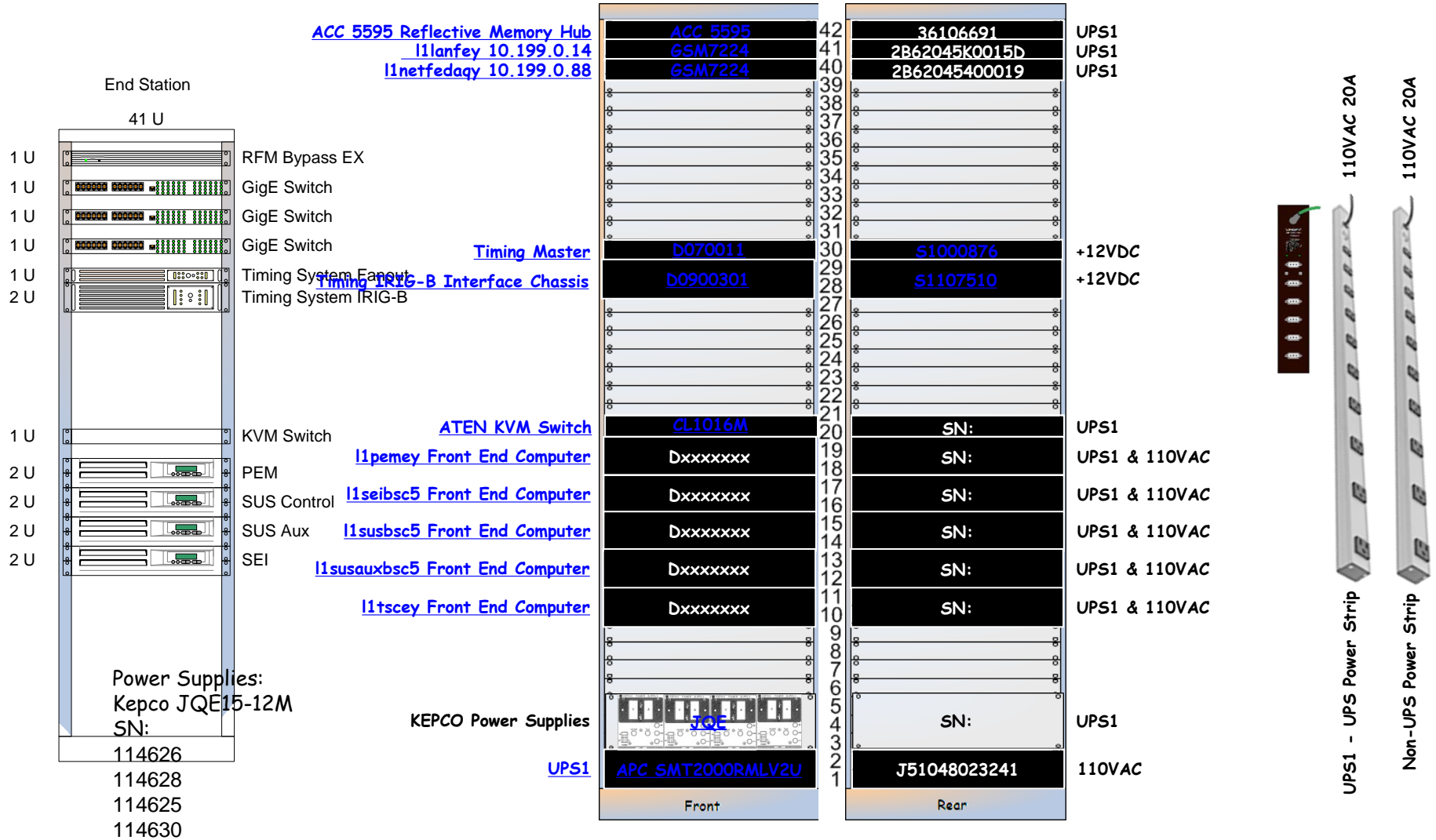

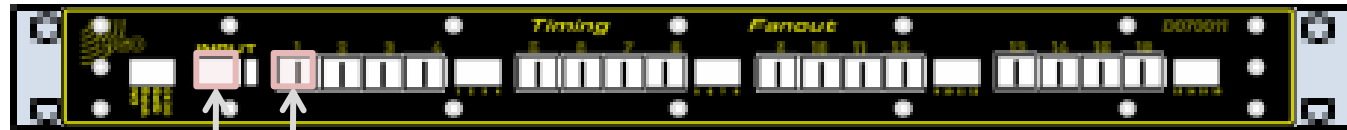

[D070011](#)

Front

To 1Y23 PP B4, B5

To 11pemey IO Front Panel



[S1000876](#)

Rear

To D070124 Green Cable

Timing IRIG-B Interface Chassis

D0900301

SN:

Power

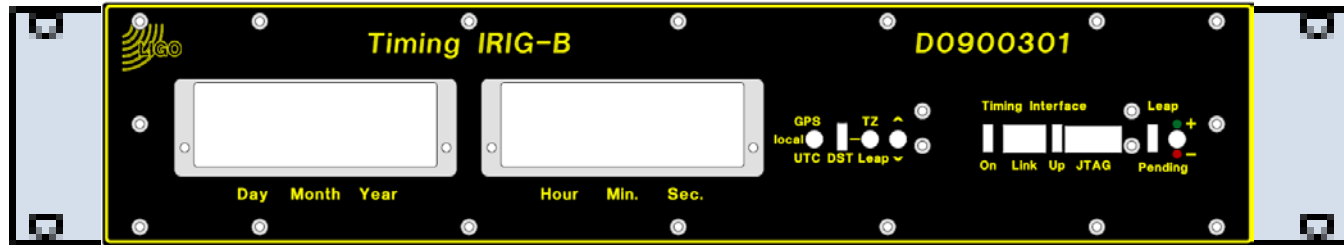

D0900301

Front

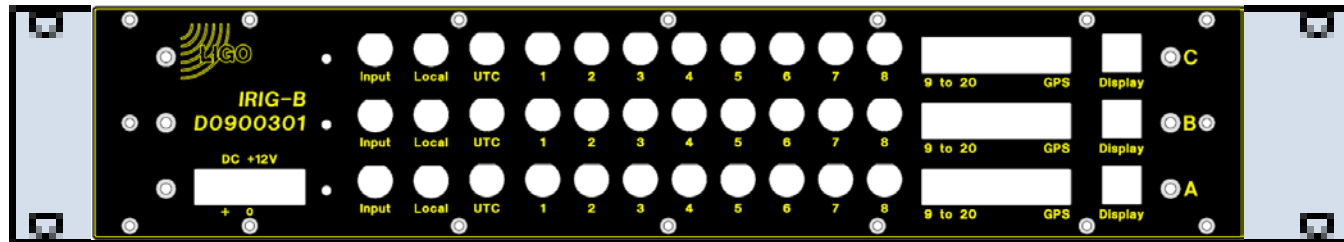

SN:

Rear

<< L1-PEM-YC1

ATEN KVM Switch

CL1016M

SN:

110VAC



CL1016M

Front



SN:

Rear

To UPS Power Strip

To L1 pemey Front End

Front End

Front End

SN:

110VAC



To UPS Power Strip



To 11pemev Front End

l1pemey I/O Extension Chassis

D1001715

S1000528

110VAC

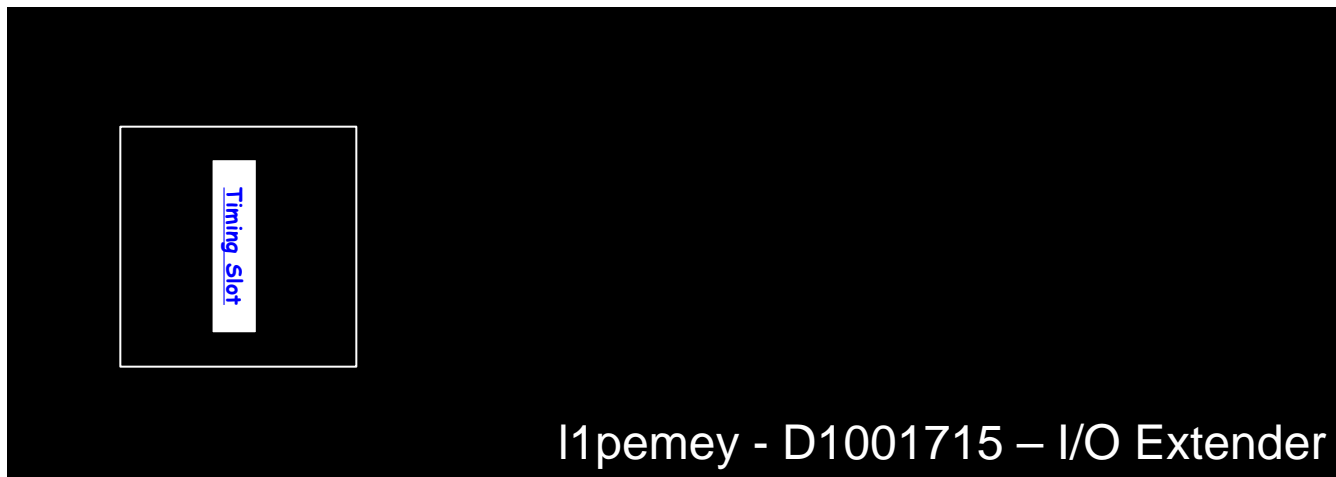

D1001715
Front

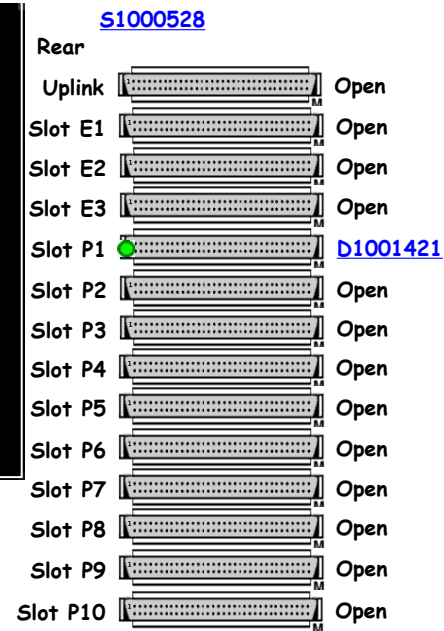
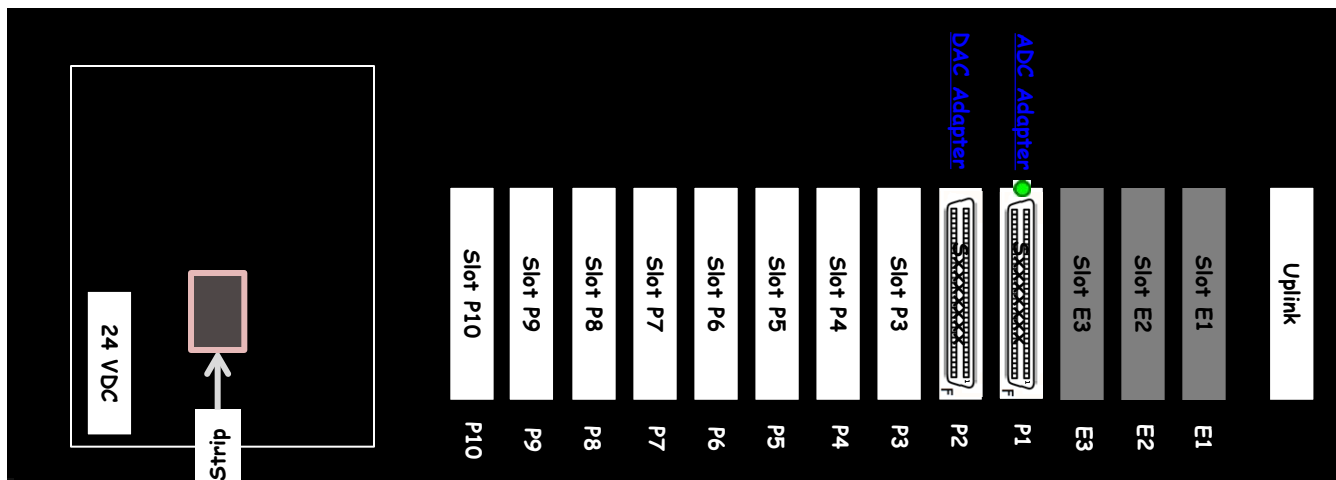

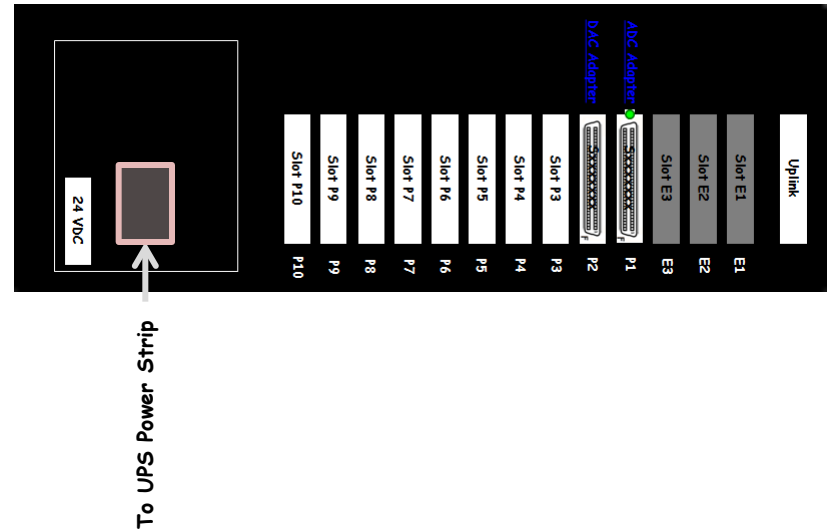
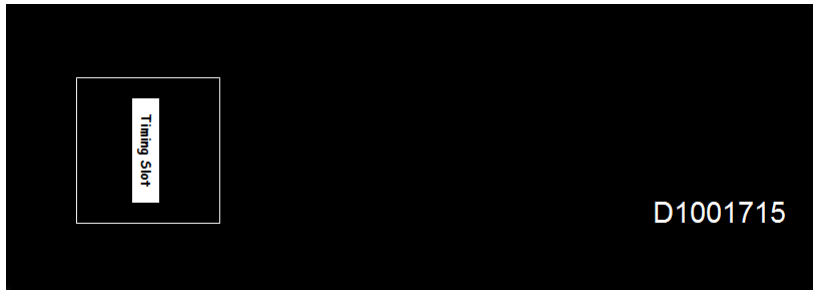

<< L1-PEM-YC1

aLIGO AA Interface Chassis
(32 BNC, x10 Gain Version)

[D1001421](#)

[S1001058](#)

+/-18VDC

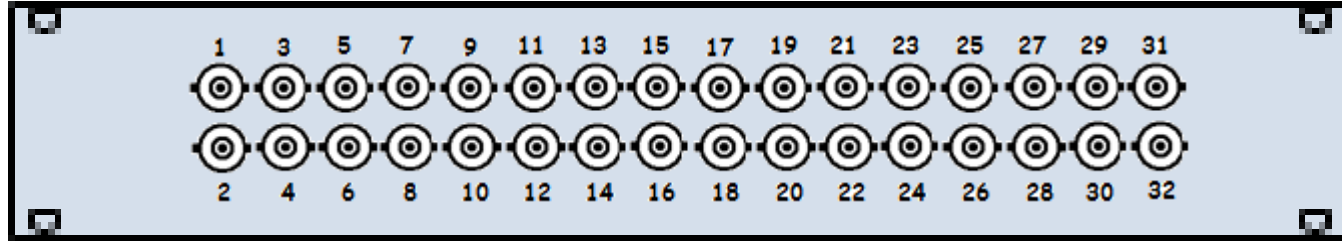

[D1001421](#)

Front

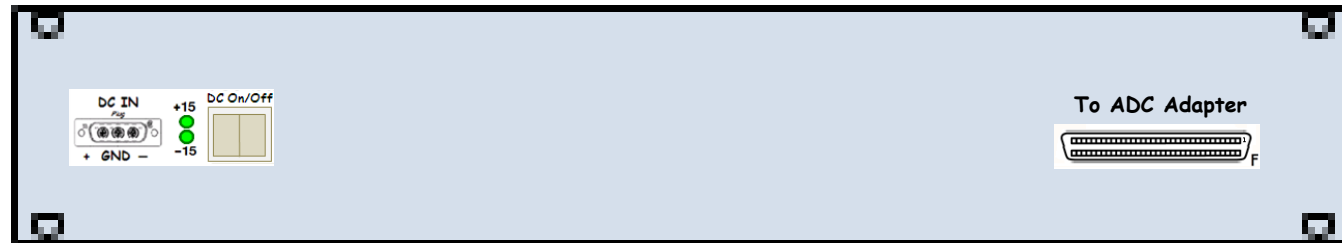
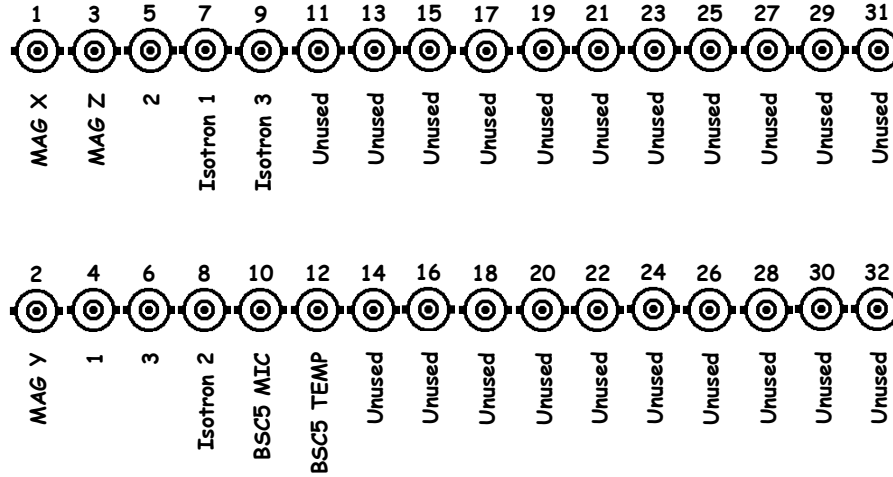

[S1001058](#)

Rear

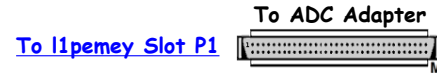

aLIGO Accelerometer Interface Chassis

D1101363

SN:

Power

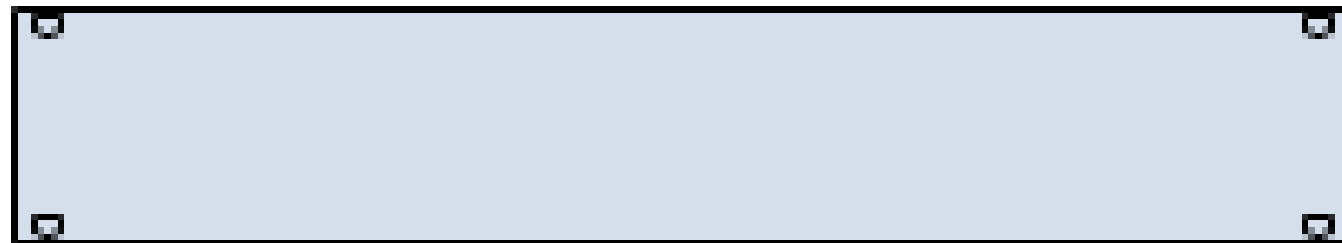
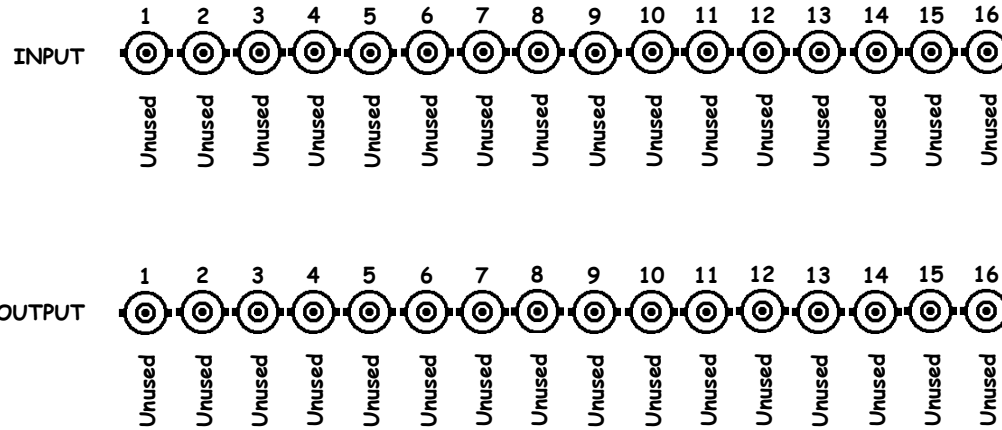
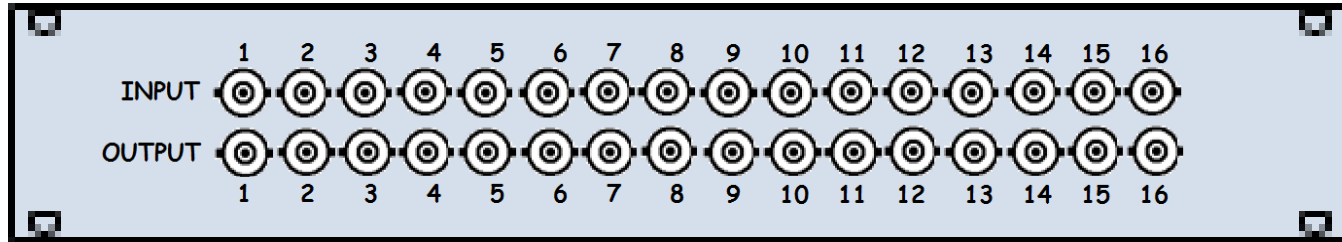

D1101363

Front

SN:

Rear

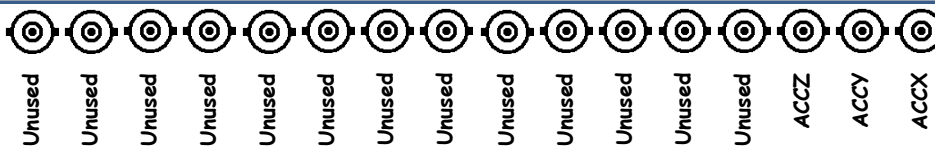
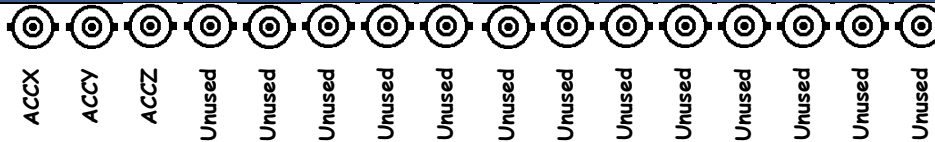
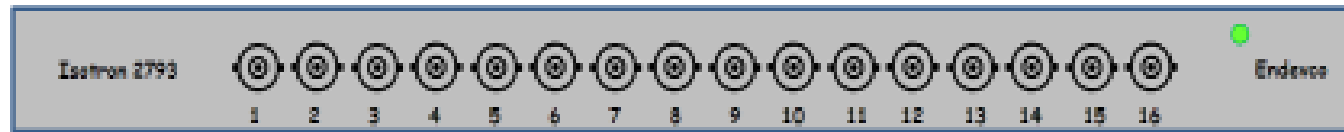

KEPCO Power Supplies

KEPCO Power Supplies

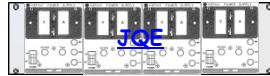

110VAC

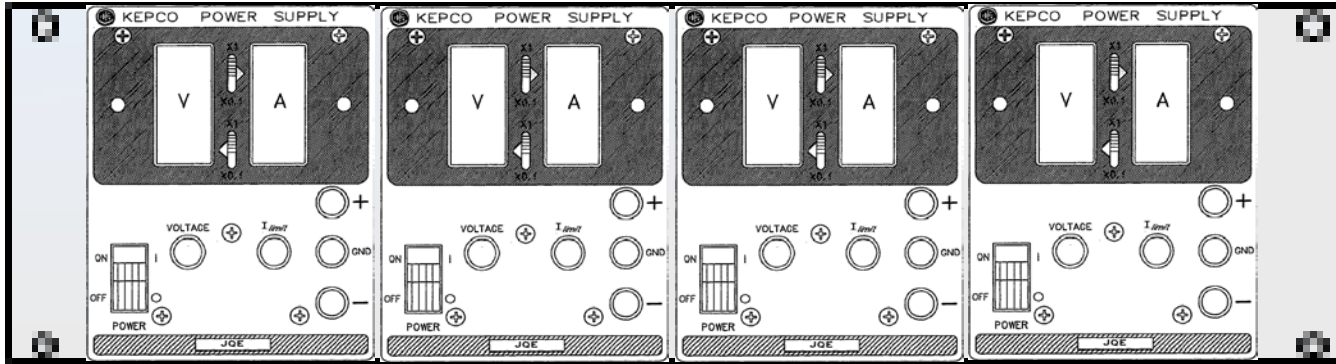

JQE

Front

KEPCO JQE 15-6:
OFF (Not Used)

KEPCO JQE 15-6:
+12VDC

KEPCO JQE 25-4:
-18VDC

KEPCO JQE 25-4:
+18VDC

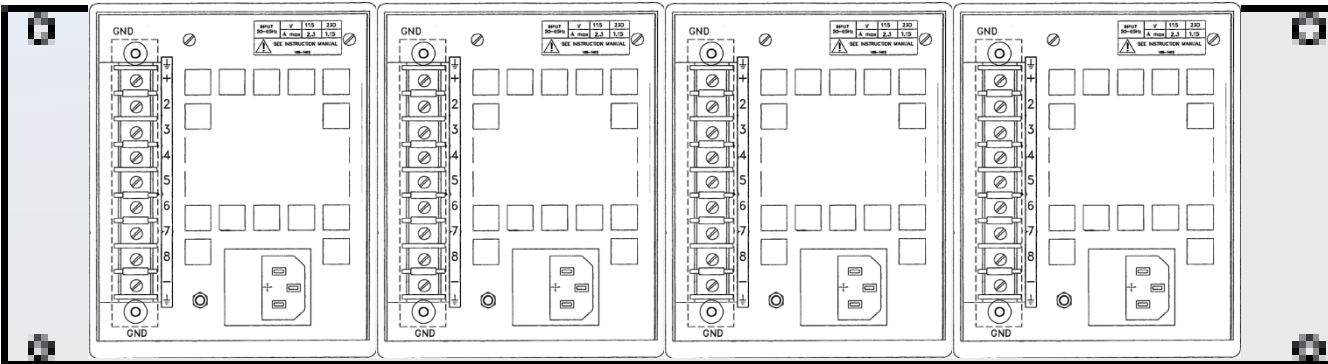

SN:

Rear

KEPCO JQE 25-4

KEPCO JQE 25-4

KEPCO JQE 15-6

KEPCO JQE 15-6

APC SMX2000RMLV2U

UPS

[APC SMX2000RMLV2U](#)

J51048019433

110VAC



[APC SMX2000RMLV2U](#)

Front

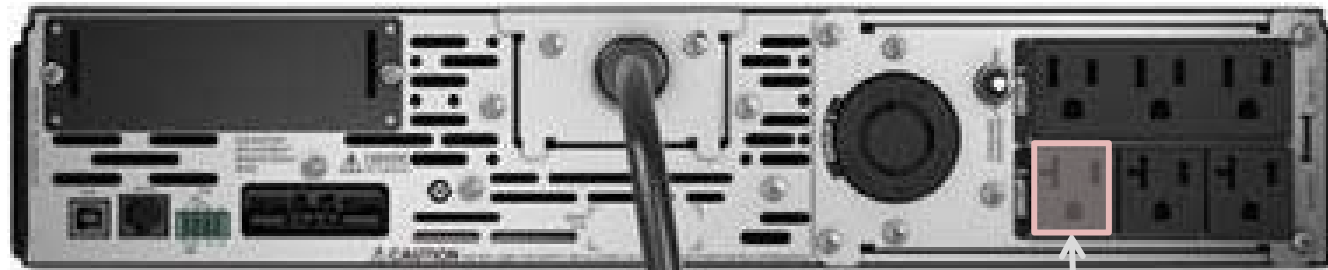

J51048023241

Rear

[To UPS Power Strip](#)

L1-FAC-YC1 (Planned)

<< CERY Racks

Facilities <Y> End Station Remote Rack Layout (LIGO-Dxxxxxxx)

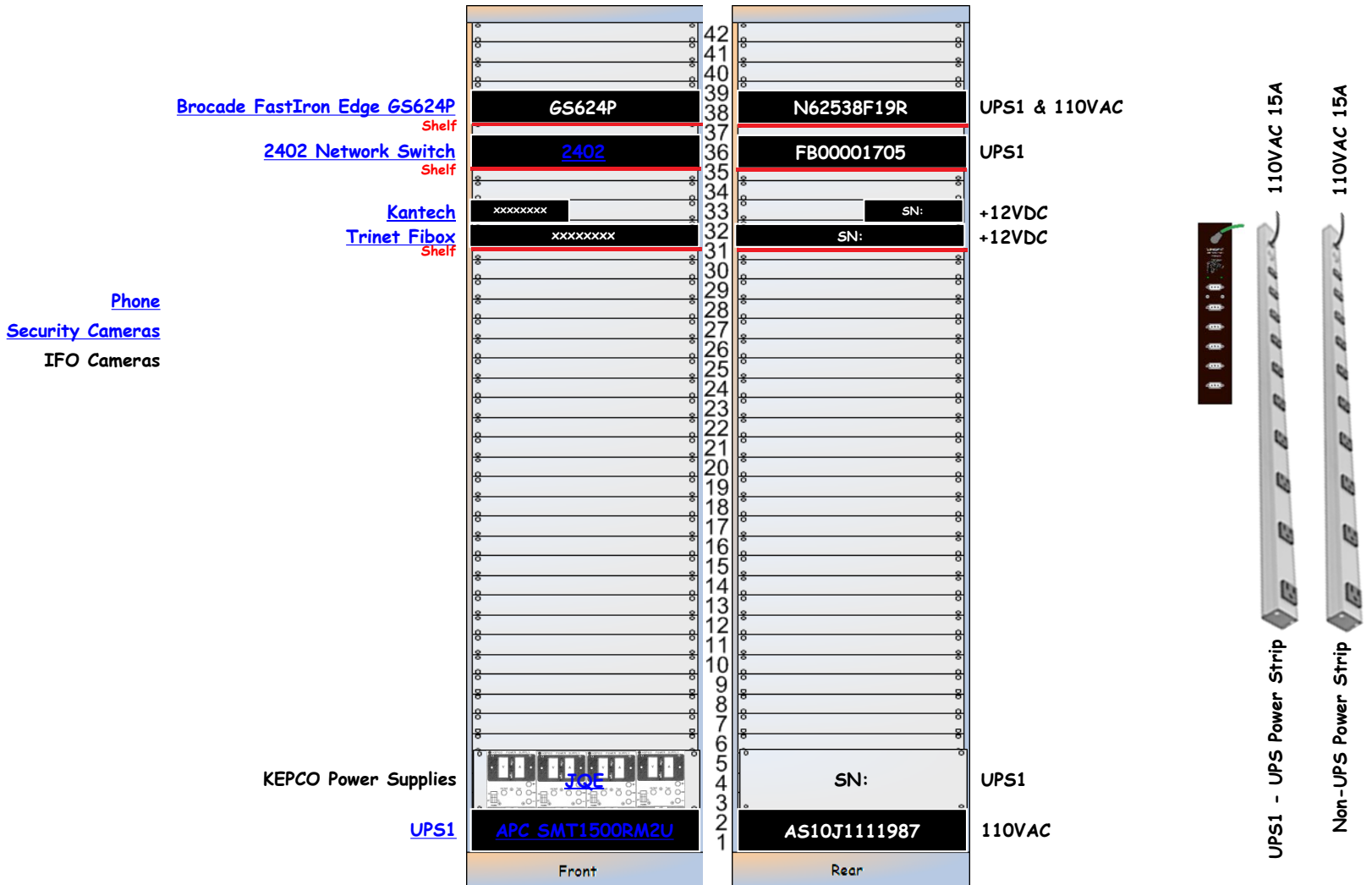

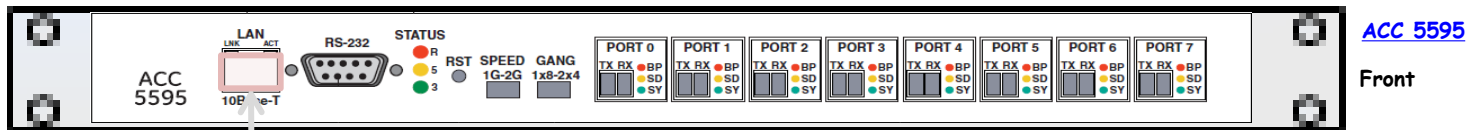

To 11lanfey port 5

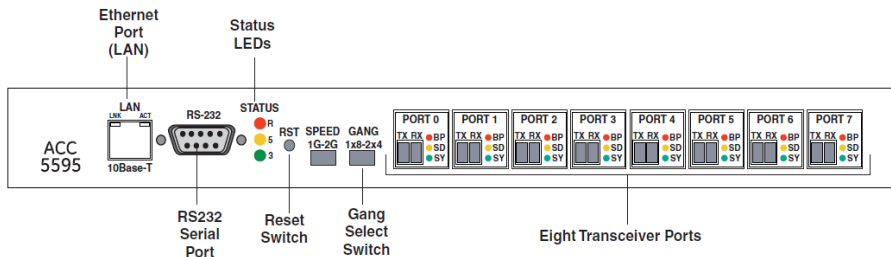
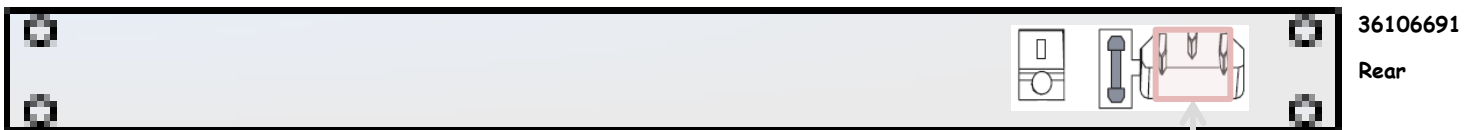

To UPS Power Strip



GSM7224

Front

CO:3F:0E:86:89:14



2 - To FE LAN Port

5 - To 5595 LAN 10BaseT

21F - To 1Y23 PP A1, A2



2B62045K0015D

Rear

To UPS Power Strip



GSM7224

Front
CO:3F:0E:86:84:04

2 - To FE NET Port

21F - To 1Y23 PP E1, E2



2B62045400019

Rear

To UPS Power Strip

<< L1-PEM-YC1

Brocade FastIron Edge GS624P

GS624P

N62538F1A3

UPS & 110VAC



GSM7224

Front

CO:3F:0E:86:88:E0

21F - To 1Y23 PP B1.B2

3 - To FE NET Port

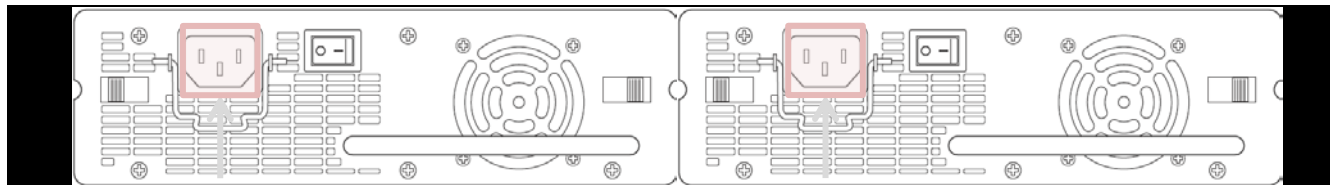

N62538F1A3

Rear

To 110 Power Strip

To UPS Power Strip

Gold Box

D070124

Negative LED: Red - UL3
 Negative LED: White - UM3
 Positive LED: Red - UM2
 Positive LED: White - LL3

Negative LED: Red - LM1
 Negative LED: White - LR14
 Positive LED: Red - UR14
 Positive LED: White - LM1

IN (From [Source](#))

Green Jacket Conductor 1 - UL1
 Green Jacket Conductor 2 - UM14
 Green Jacket Conductor 3 - LL1

IN (From [Source](#))

Orange Jacket White - UR13
 Orange Jacket Black - LM2
 Orange Jacket Green - LR13

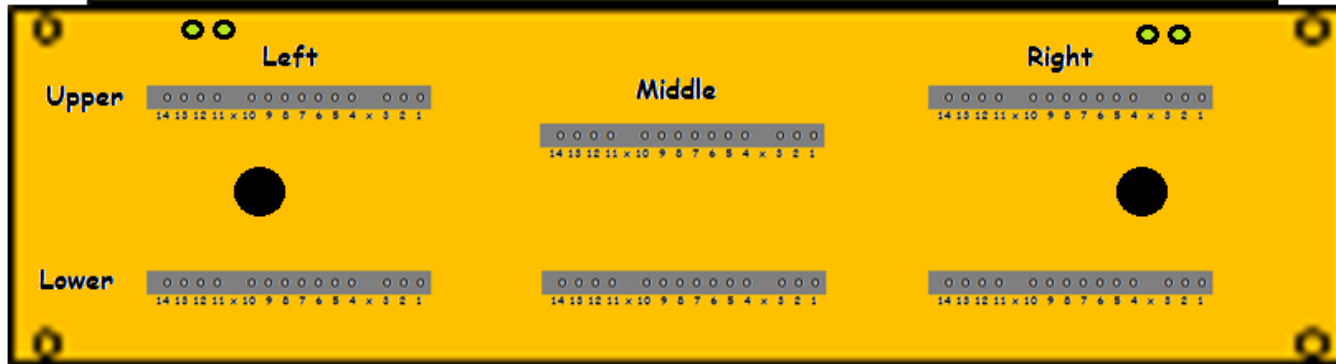

OUT-1 (To [Load](#))

Green Jacket Conductor 1 - UL2
 Green Jacket Conductor 2 - UM11
 Green Jacket Conductor 3 - LL2

OUT-1 (To [Load](#))

Orange Jacket White - UR7
 Orange Jacket Black - LM5
 Orange Jacket Green - LR8

OUT-2 (To [Load](#))

Orange Jacket White - UR8
 Orange Jacket Black - LM4
 Orange Jacket Green - LR9

OUT-3 (To [Load](#))

Orange Jacket White - UR1
 Orange Jacket Black - LM3
 Orange Jacket Green - LR1

Remaining 1Y23 Hardware

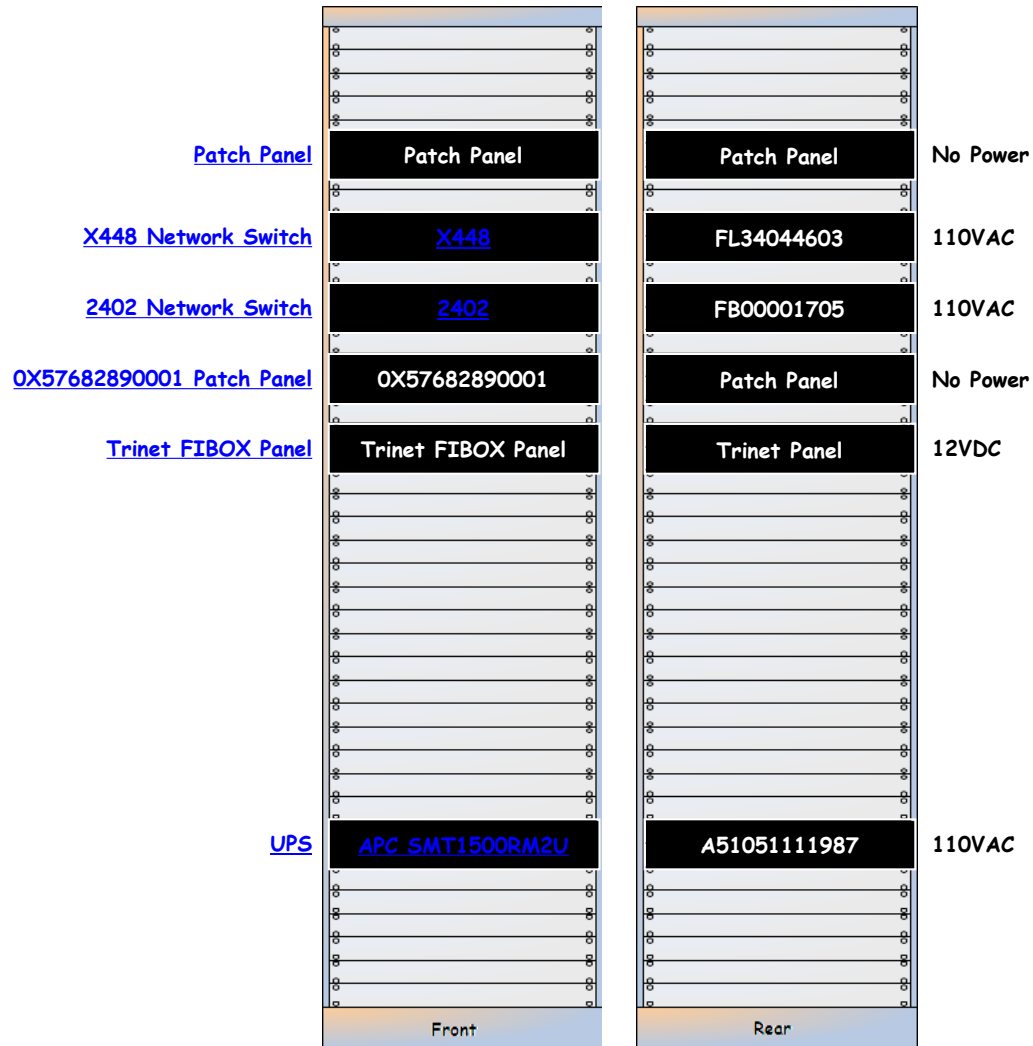

110VAC 20A
Non-UPS Power Strip

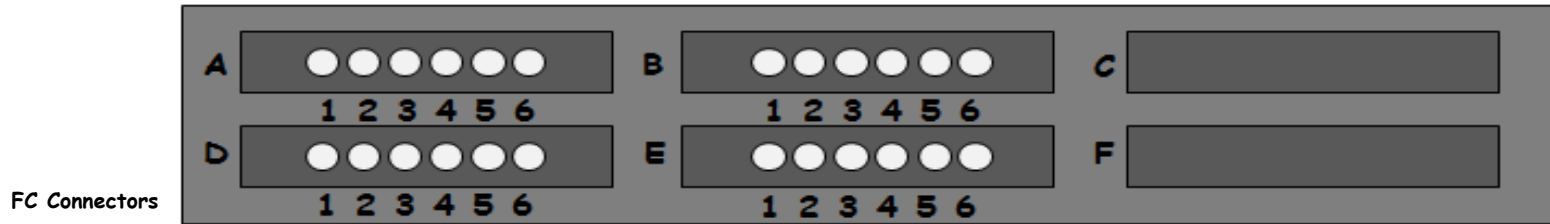

| | | | | | | | | |
|---|---|----|---|---|----|-------|---|----|
| l1lanfey 21F (Clear) | ↔ | A1 | Empty | ↔ | B1 | Empty | ↔ | C1 |
| l1lanfey 21F (None) | ↔ | A2 | TR30300WDM OPT In/Out | ↔ | B2 | Empty | ↔ | C2 |
| X448 1F | ↔ | A3 | Empty | ↔ | B3 | Empty | ↔ | C3 |
| X448 1F | ↔ | A4 | D070011 Fanout Input | ↔ | B4 | Empty | ↔ | C4 |
| ACC-5595 Port 6 (Clear) | ↔ | A5 | D070011 Fanout Input | ↔ | B5 | Empty | ↔ | C5 |
| ACC-5595 Port 6 (None) | ↔ | A6 | VT5030 Opt Out | ↔ | B6 | Empty | ↔ | C6 |
| VT430 Opt In/Out | ↔ | D1 | l1netfedaqy 21F (Clear) | ↔ | E1 | Empty | ↔ | F1 |
| 7711-R Opt In/Out | ↔ | D2 | l1netfedaqy 21F (None) | ↔ | E2 | Empty | ↔ | F2 |
| 2402 26F (White) | ↔ | D3 | 2402 26F (Yellow) | ↔ | E3 | Empty | ↔ | F3 |
| Empty | ↔ | D4 | Empty | ↔ | E4 | Empty | ↔ | F4 |
| 1Y23 PP Port 6 | ↔ | D5 | Empty | ↔ | E5 | Empty | ↔ | F5 |
| 1Y23 PP Port 5 | ↔ | D6 | Empty | ↔ | E6 | Empty | ↔ | F6 |

<< 1Y23

Patch Panel

Patch Panel

Patch Panel

No Power



FC Connectors

- [l1lanfey 21F \(Clear\)](#) ↔ 1-1
- [l1lanfey 21F \(None\)](#) ↔ 1-2
- [X448 1F](#) ↔ 1-3
- [X448 1F](#) ↔ 1-4
- [ACC-5595 Port 6 \(Clear\)](#) ↔ 1-5
- [ACC-5595 Port 6 \(None\)](#) ↔ 1-6

- [VT430 Opt In/Out](#) ↔ 3-1
- [7711-R Opt In/Out](#) ↔ 3-2
- [2402 26F \(White\)](#) ↔ 3-3
- Empty ↔ 3-4
- [1Y23 PP Port 6](#) ↔ 3-5
- [1Y23 PP Port 5](#) ↔ 3-6

- Empty ↔ 2-1
- [TR30300WDM OPT In/Out](#) ↔ 2-2
- Empty ↔ 2-3
- [D070011 Fanout Input](#) ↔ 2-4
- [D070011 Fanout Input](#) ↔ 2-5
- [VT5030 Opt Out](#) ↔ 2-6

- [l1netfedaqy 21F \(Clear\)](#) ↔ 4-1
- [l1netfedaqy 21F \(None\)](#) ↔ 4-2
- [2402 26F \(Yellow\)](#) ↔ 4-3
- Empty ↔ 4-4
- Empty ↔ 4-5
- Empty ↔ 4-6

- Empty ↔ C1
- Empty ↔ C2
- Empty ↔ C3
- Empty ↔ C4
- Empty ↔ C5
- Empty ↔ C6

- Empty ↔ F1
- Empty ↔ F2
- Empty ↔ F3
- Empty ↔ F4
- Empty ↔ F5
- Empty ↔ F6

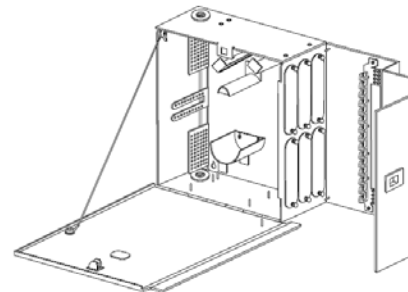

WCH-06P (up to 72 fibers) | Drawing CPC-220/5/33

<< 1Y23

X448 Network Switch

X448

FL34044603

110VAC

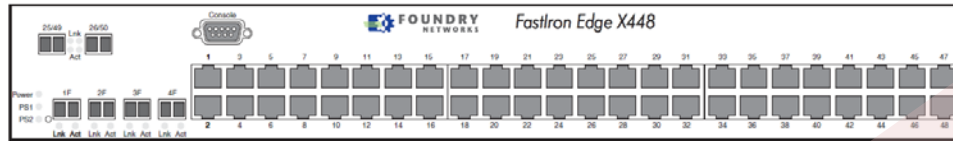

To 1Y23 PP A4(Yellow), A3(White)

- Empty ↔ 1F
- Empty ↔ 2F
- Empty ↔ 3F
- Empty ↔ 4F

- | | |
|------------|------------|
| Empty ↔ 01 | Empty ↔ 25 |
| Empty ↔ 02 | Empty ↔ 26 |
| Empty ↔ 03 | Empty ↔ 27 |
| Empty ↔ 04 | Empty ↔ 28 |
| Empty ↔ 05 | Empty ↔ 29 |
| Empty ↔ 06 | Empty ↔ 30 |
| Empty ↔ 07 | Empty ↔ 31 |
| Empty ↔ 08 | Empty ↔ 32 |
| Empty ↔ 09 | Empty ↔ 33 |
| Empty ↔ 10 | Empty ↔ 34 |
| Empty ↔ 11 | Empty ↔ 35 |
| Empty ↔ 12 | Empty ↔ 36 |
| Empty ↔ 13 | Empty ↔ 37 |
| Empty ↔ 14 | Empty ↔ 38 |
| Empty ↔ 15 | Empty ↔ 39 |
| Empty ↔ 16 | Empty ↔ 40 |
| Empty ↔ 17 | Empty ↔ 41 |
| Empty ↔ 18 | Empty ↔ 42 |
| Empty ↔ 19 | Empty ↔ 43 |
| Empty ↔ 20 | Empty ↔ 44 |
| Empty ↔ 21 | Empty ↔ 45 |
| Empty ↔ 22 | Empty ↔ 46 |
| Empty ↔ 23 | Empty ↔ 47 |
| Empty ↔ 24 | Empty ↔ 48 |

G12289
10.100.0.14
Ports 3-16 OPS LAN
Ports 17-48 VAC LAN

To Computer in Electronics Room

To Isolated 110VAC

To VACUUM Rack

To UPS

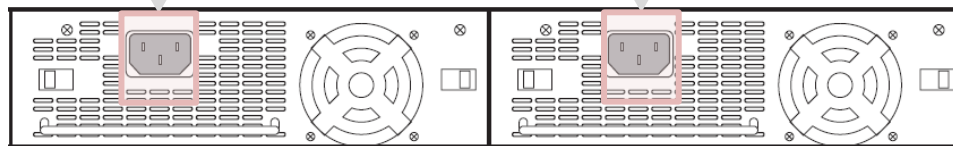

PS2

PS1

OBSOLETE

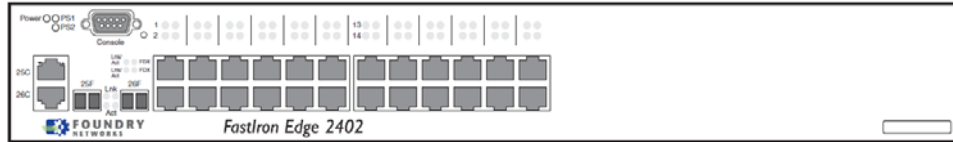

- Empty ↔ 01
- Empty ↔ 02
- Empty ↔ 03
- Empty ↔ 04
- Empty ↔ 05
- Empty ↔ 06
- To Camera on Reel ↔ 07
- Empty ↔ 08
- To Trinet/Trinet ↔ 09
- Empty ↔ 10
- To Trinet/Trinet ↔ 11
- Empty ↔ 12
- Empty ↔ 13
- To Seimens ↔ 14
- Empty ↔ 15
- Empty ↔ 16
- Empty ↔ 17
- Empty ↔ 18
- Empty ↔ 19
- Empty ↔ 20
- To Weather Station ??? ↔ 21
- Empty ↔ 22
- Empty ↔ 23
- Empty ↔ 24

- Empty ↔ 25C
- Empty ↔ 26C
- To Special Cable CSR1 ↔ 25F
- To 1Y23 PP D3, E3 ↔ 26F

G12039
192.168.253.30

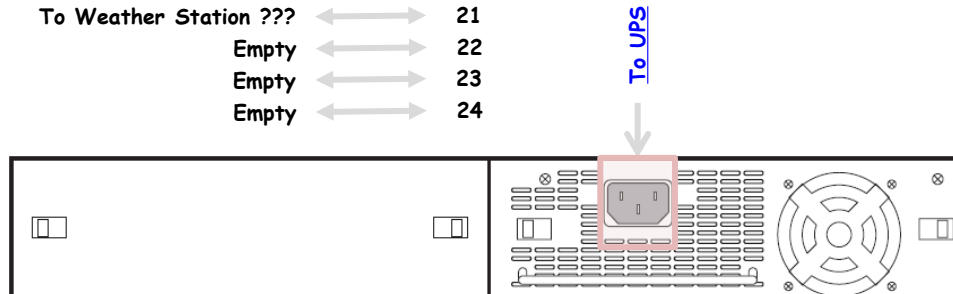

PS1

<< 1Y23

OX57682890001 Patch Panel

OX57682890001

Patch Panel

No Power

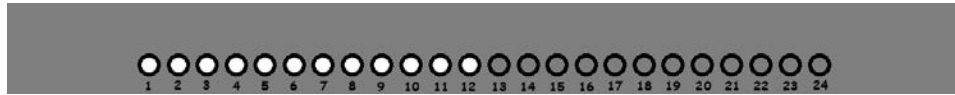

ST Connectors

| | | |
|---|---|----|
| To J/E-CF-01 Tx to 2402 P9 | ↔ | 01 |
| To J/E-CF-01 Rx to 2402 P9 | ↔ | 02 |
| To Trinet FIBOX | ↔ | 03 |
| Empty | ↔ | 04 |
| Empty | ↔ | 05 |
| Empty | ↔ | 06 |
| To J/E-CF-01 Rx to 2402 P11 | ↔ | 07 |
| To J/E-CF-01 Tx to 2402 P11 | ↔ | 08 |
| Empty | ↔ | 09 |
| Empty | ↔ | 10 |
| Empty | ↔ | 11 |
| Empty | ↔ | 12 |
| Empty | ↔ | 13 |
| Empty | ↔ | 14 |
| Empty | ↔ | 15 |
| Empty | ↔ | 16 |
| Empty | ↔ | 17 |
| Empty | ↔ | 18 |
| Empty | ↔ | 19 |
| Empty | ↔ | 20 |
| Empty | ↔ | 21 |
| Empty | ↔ | 22 |
| Empty | ↔ | 23 |
| Empty | ↔ | 24 |

Fiber Bundles

<< 1Y23

Trinet FIBOX Panel

Trinet **FIBOX** Panel

Trinet Panel

12VDC

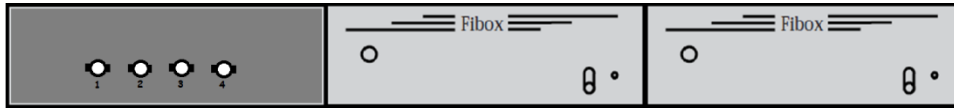

- Empty ↔ 1
- Trinet Z ↔ 2
- Trinet Y ↔ 3
- Trinet X ↔ 4

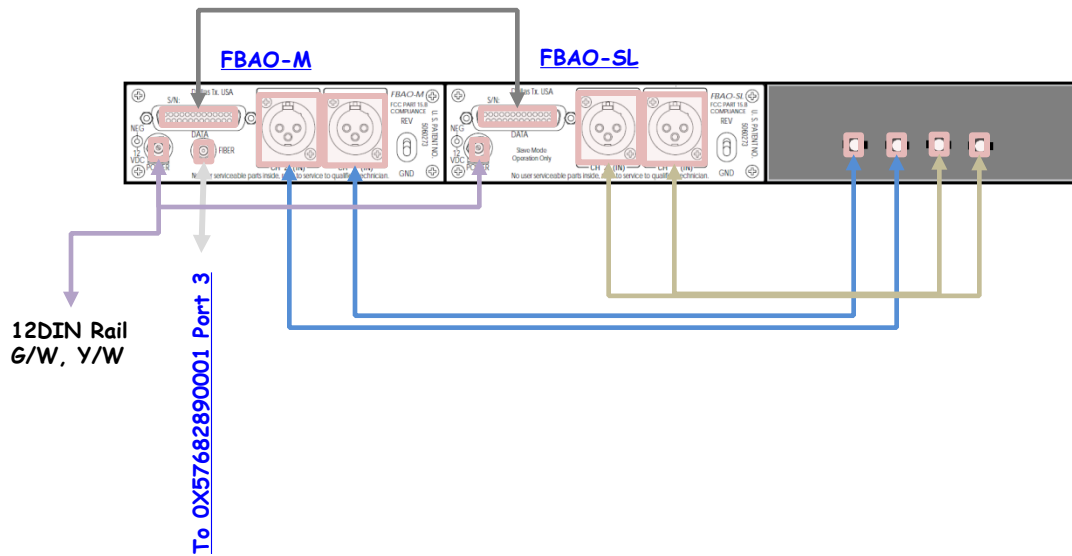

<< 1Y23

Magnetometer: [Bartington Instruments](#)
MAG-03MC

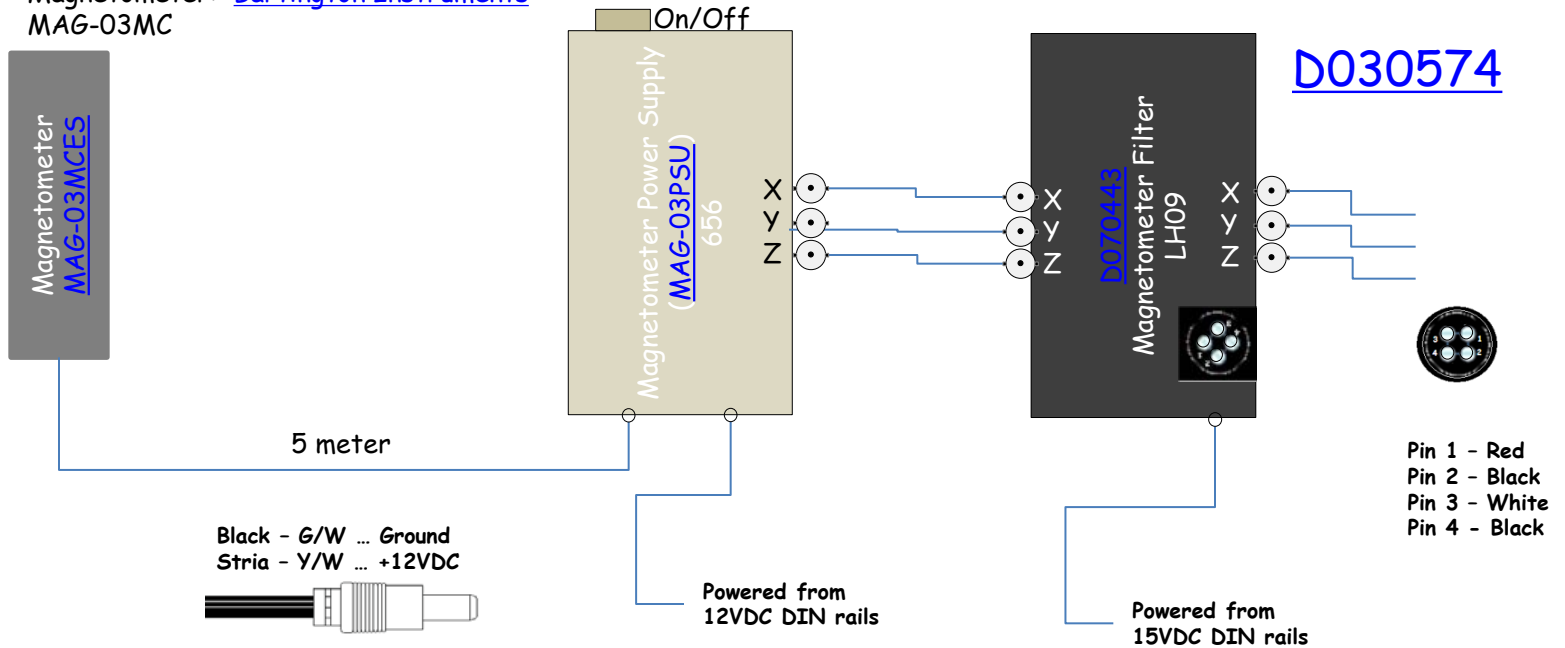

Black - G/W ... Ground
Stria - Y/W ... +12VDC



Powered from
12VDC DIN rails

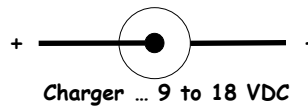

Powered from
15VDC DIN rails

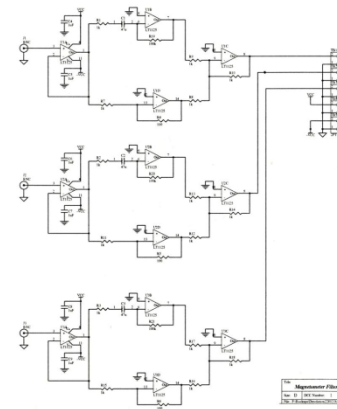

Magnetometer Filter Board

[<< 1Y23](#)

I/O Cameras

[VT5030 IFS](#)
International
Fiber Systems,
Inc.
IFS.com
Optical Out:
[To 1Y23 PP B6](#)
Power: 12VDC
Video Input:
Camera 1
Camera 2

Powered from
DIN rails

Security Cameras

[VT7430-2DRDT](#)
Optical In/Out:
[To 1Y23 PP D1](#)
Power: 12VDC
Output: Ch1,
Ch2, Ch3 BNCs
to Cameras

Powered from
Wall Wart from
Isolated Power

Revere Video
Master Power
Supply Model
[RT24/16500](#)
Outputs to
Cameras 1,2,3

*LEDs on with
bad fuse
Note: 8 LEDs
are on.

AC Powered
from Isolated
Power

Kantech

Fiber Options
[7711-R \(501R\)](#)
Optical In/Out:
[To 1Y23 PP D2](#)
Power: 13.5VDC
from Wall Wart

Blue CAT5:
1=O/W and
B/W, 4=O, 7=B

Powered from
Wall Wart from
Isolated Power

Seismic Vault

J/E-CF-01
TriNet
Converter
CAT5:
[To 2402 P9](#)
TX:
[To 0X57... P1](#)
RX:
[To 0X57... P2](#)
Power: 12VDC

Powered from
DIN rails

J/E-CF-01
TriNet
Converter
CAT5:
[To 2402 P11](#)
TX:
[To 0X57... P8](#)
RX:
[To 0X57... P7](#)
Power: 12VDC

Powered from
DIN rails

Phone

[TR3030WDM](#)
GE Security
Optical In/Out:
[To 1Y23 PP B2](#)
Phone: Copper to
VEA
Power: 12VDC

Powered from Wall Wart from
Tripp-Lite UPS
Model BC320
9834DY0BC614000661 To 6-
Outlet Power Strip in Non-
isolated wall socket

<< 1Y23

Kantech

Fiber Options
[7711-R \(501R\)](#)
Optical In/Out:
[To 1Y23 PP D2](#)
Power: 13.5VDC
from Wall Wart

Blue CAT5:
1=O/W and
B/W, 4=O, 7=B

Powered from
Wall Wart from
Isolated Power

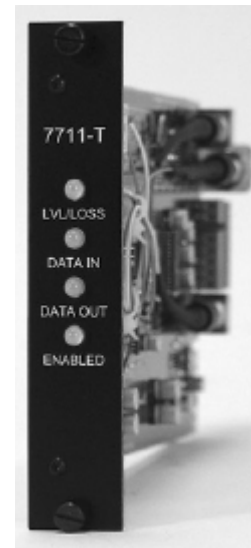
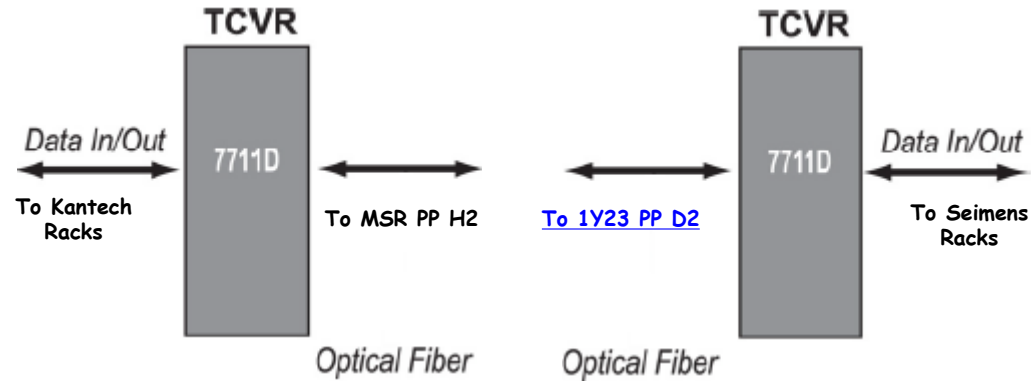

Security Cameras

Reverse Video
Master Power
Supply Model
[RT24/16500](#)

Outputs to
Cameras 1,2,3

*LEDs on with
bad fuse
Note: 8 LEDs
are on.

AC Powered
from Isolated
Power



RT24/16500

AC Power120 VAC LED supervised
Non-grounded power cord
furnished

Output24 VAC, 8 amps total

Outputs16 @ 500mA individually
fused at 1/2 amp and
individually supervised

Dimensions7.5" W x 8.25" H x 3.5" D

CabinetHeavy gauge steel



VAC

<< 1Y23

Security Cameras

VT7430-2DRDT
 Optical In/Out:
 To 1Y23 PP D1
 Power: 12VDC
 Output: Ch1,
 Ch2, Ch3 BNCs
 to Cameras

Powered from
 Wall Wart from
 Isolated Power

cameras
 75-ohm coaxial cables

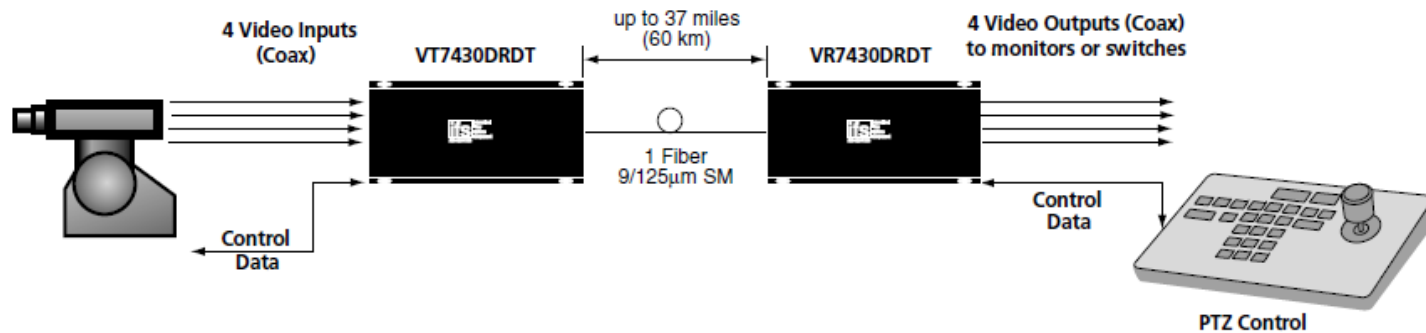

Cameras

[VT5030 IFS](#)
International
Fiber Systems,
Inc.
IFS.com
Optical Out:
[To 1Y23 PP B6](#)
Power: 12VDC
Video Input:
Camera 1
Camera 2

Powered from
DIN rails

cameras
75-ohm coaxial cables

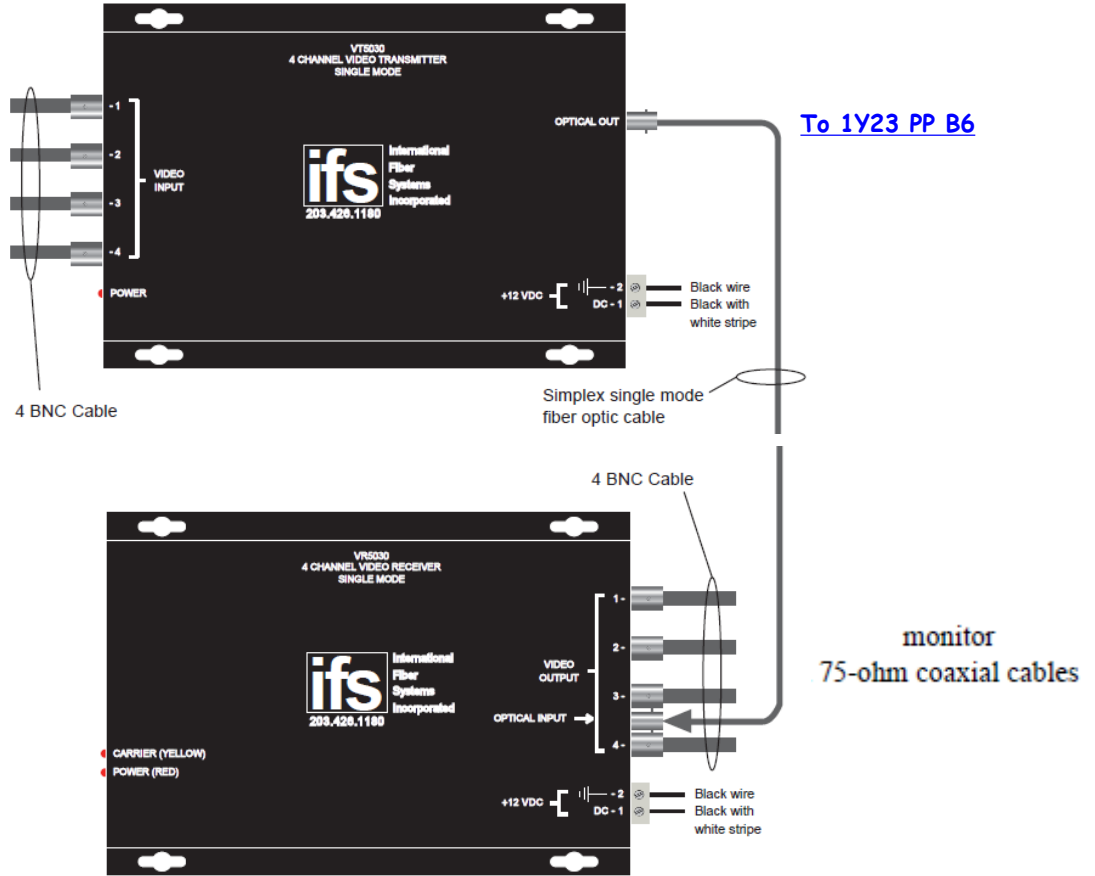

Y-End - Trinet

Seismic Vault

| | |
|--|---|
| <p>J/E-CF-01 TriNet Converter CAT5: To 2402 P9 TX: To OX57... P1 RX: To OX57... P2 Power: 12VDC</p> | <p>J/E-CF-01 TriNet Converter CAT5: To 2402 P11 TX: To OX57... P8 RX: To OX57... P7 Power: 12VDC</p> |
|--|---|

Powered from
DIN rails

Powered from
DIN rails

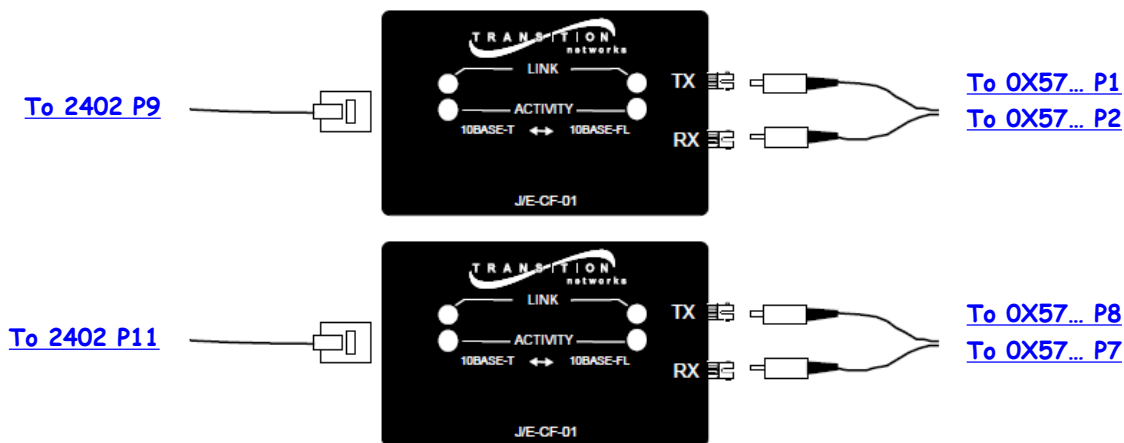

For network installation, the J/E-CF-01 media converter provides an RJ-45 twisted pair connector and a set of RX (receive) and TX (transmit) ST connectors to 850 nm multimode fiber-optic cable.

Y-End - Phone

Phone

[TR3030WDM](#)
 GE Security
 Optical In/Out:
[To 1Y23 PP B2](#)
 Phone: Copper to
 VEA
 Power: 12VDC

Powered from Wall Wart from
 Tripp-Lite UPS
 Model BC320
 9834DY0BC614000661 To 6-
 Outlet Power Strip in Non-
 isolated wall socket



System Design

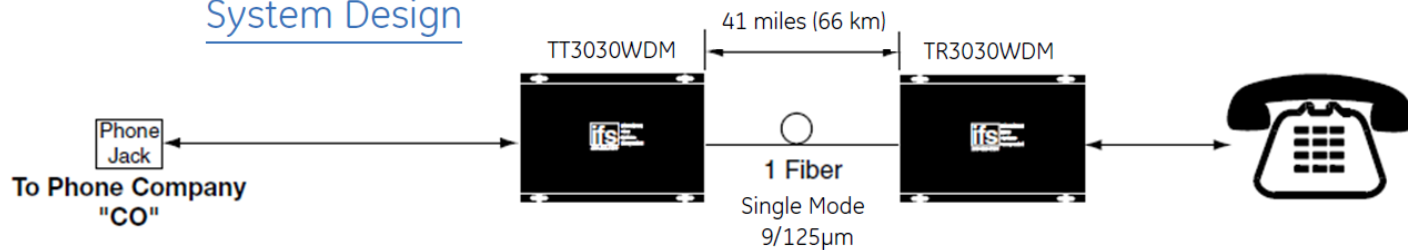

APC SMT1500RM2U

UPS

APC SMT1500RM2U

A51051111987

110VAC

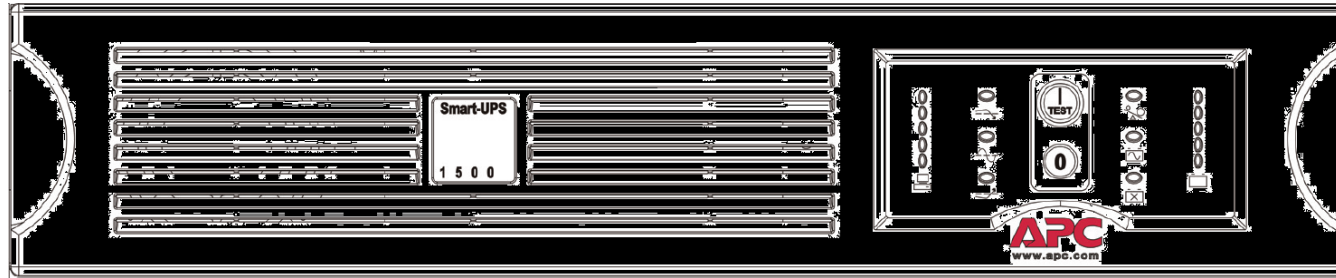

APC SMT1500RM2U

Front

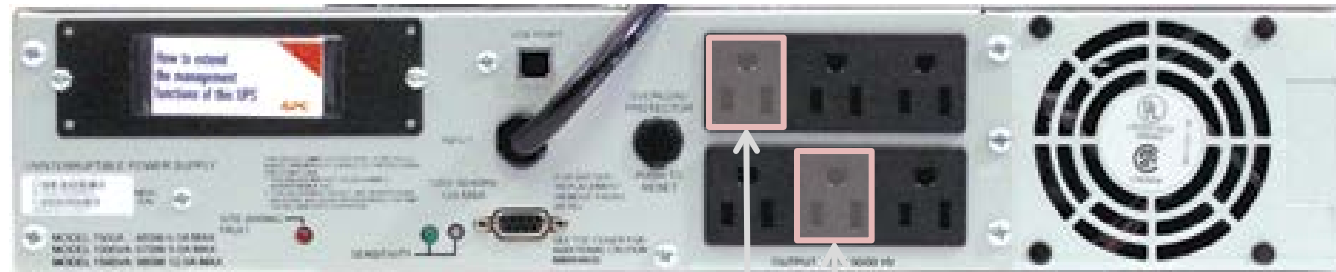

A51051111987

Rear

To 2402 PS1

To X448 PS1

End Station Remote Rack Layout

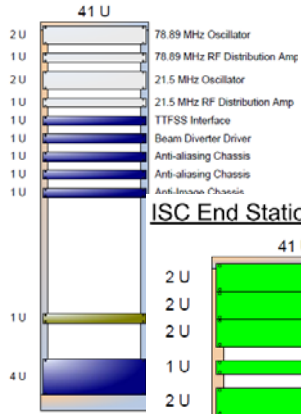

End Station Remote Rack Layout

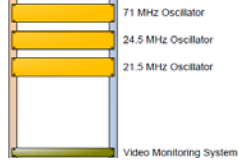

ISC End Station Remote Rack Layout

LIGO D1001459

- +12VDC
- 12VDC
- +18VDC
- 18VDC
- +24VDC
- 24VDC

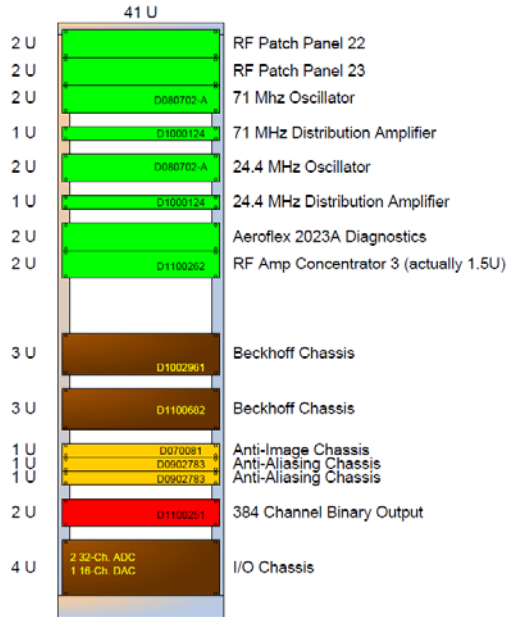

LIGO-D1001459-v8

79.89 MHz Oscillator

79.89 MHz RF Distribution Amplifier

21.5 MHz Oscillator

RF Distribution Amplifier

TTFSS Interface

Beam Diverter Driver

Anti-Alias Chassis

Anti-Alias Chassis

Chassis

Chassis

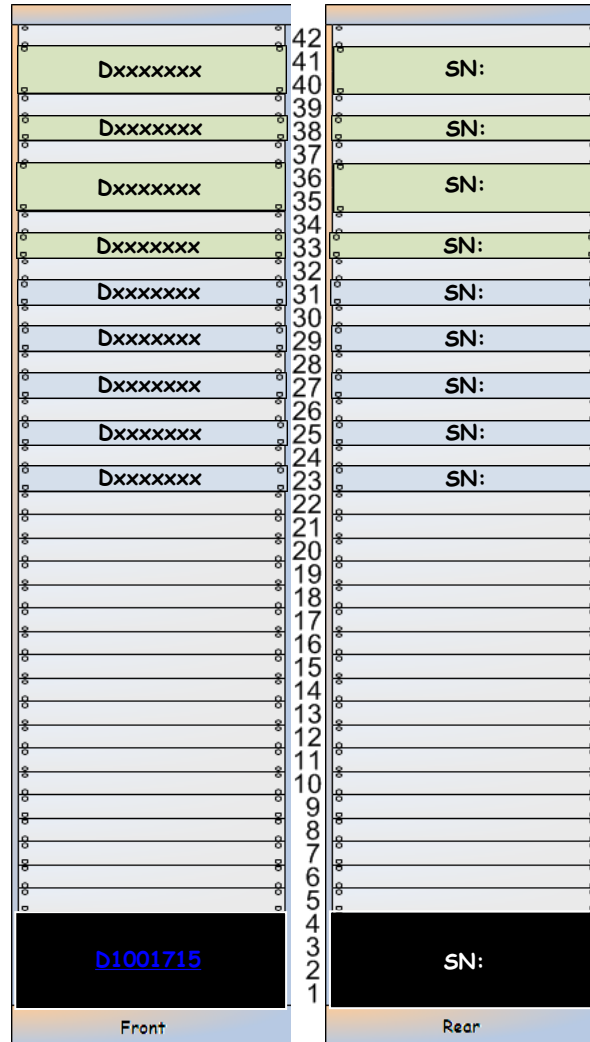

±12@1A;
±24@1A

+24@1A

±12@1A;
±24@1A

+24@1A

±18@1A; ±24@1A

±18@0.25A

±18@1A

±18@1A

±18@0.5A

+24@5A



PSY-001



PSO-001

L1-TCS-YC1

TCS part of ICS<Y> Rack Layout ([LIGO-D1200258](#))

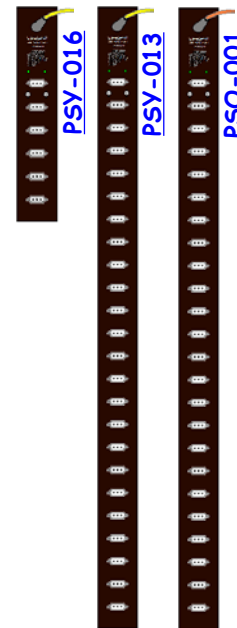
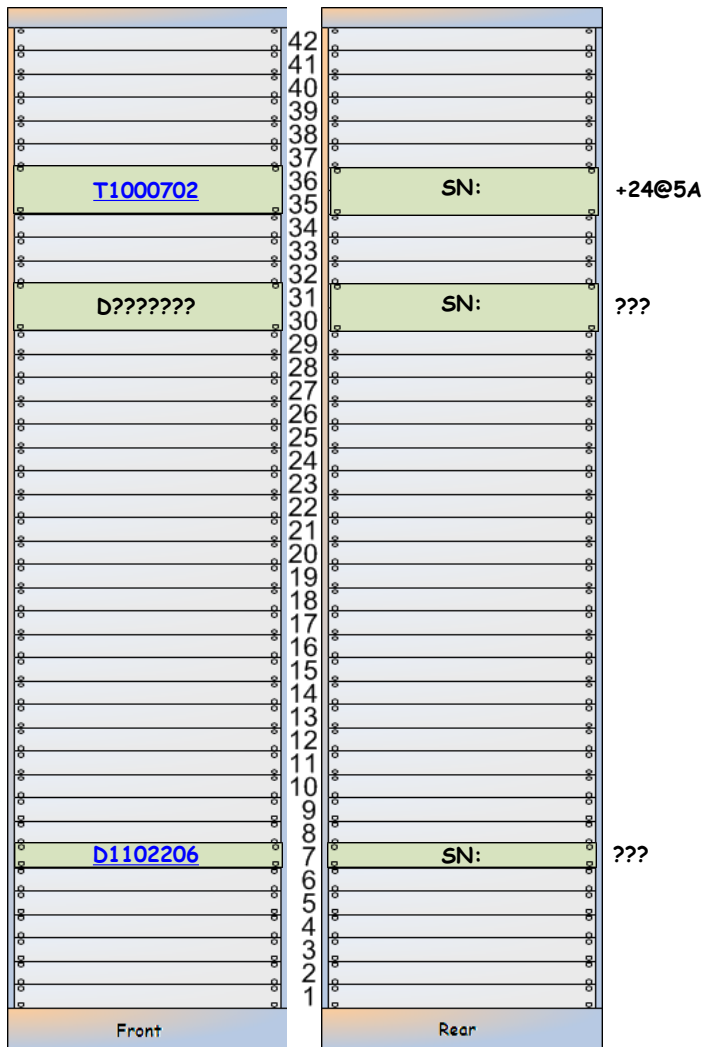
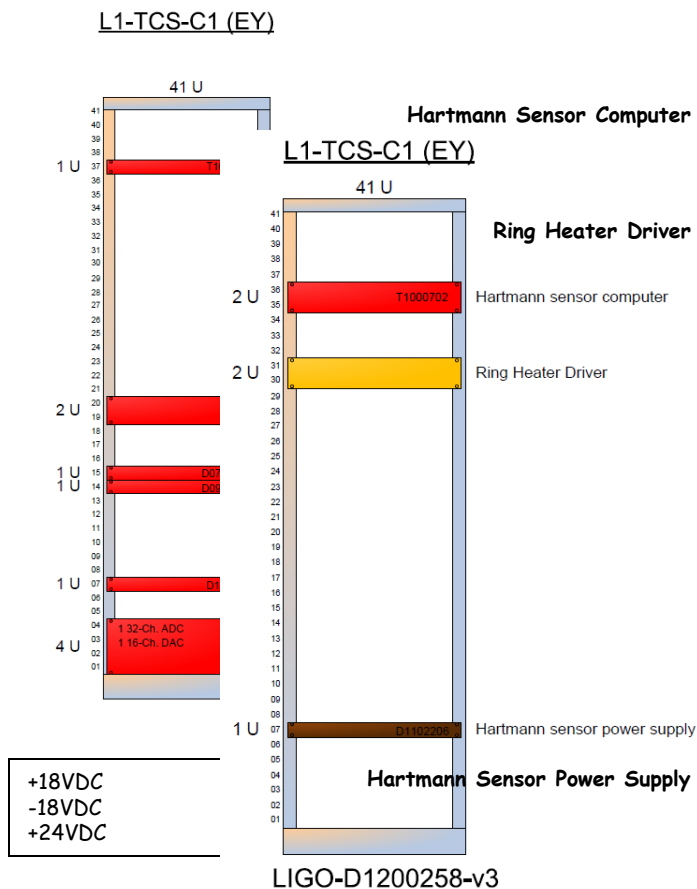

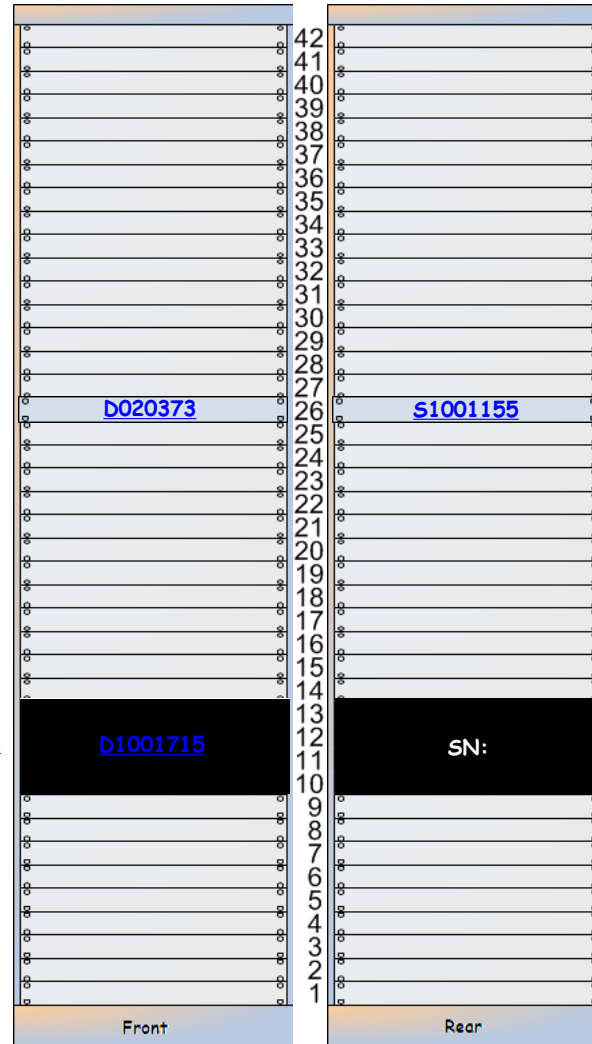
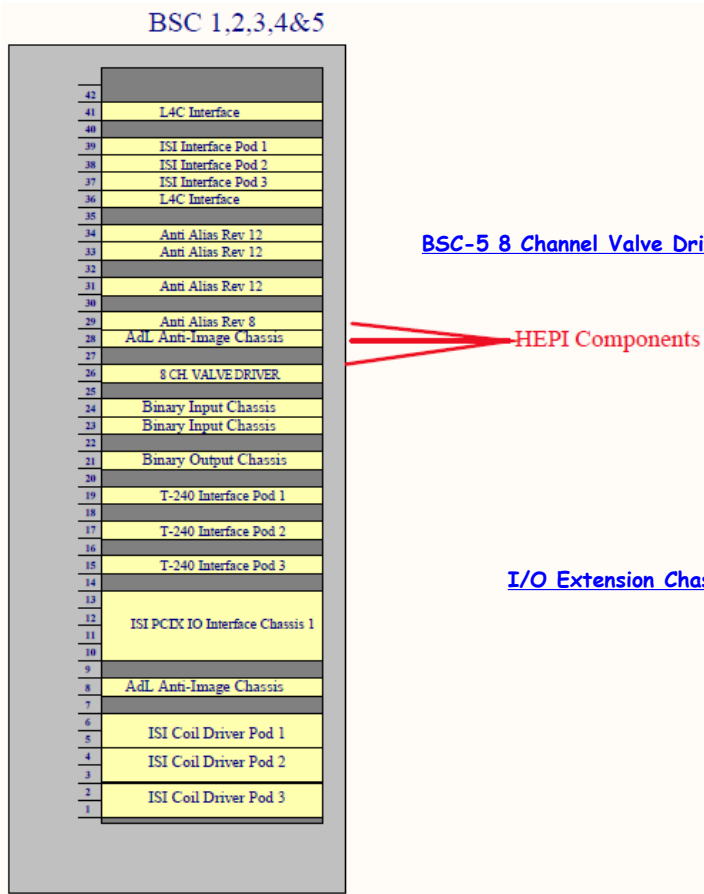

Power

+24@5A

| | |
|--------|-----|
| +18VDC | 4A |
| -18VDC | 4A |
| +24VDC | 15A |

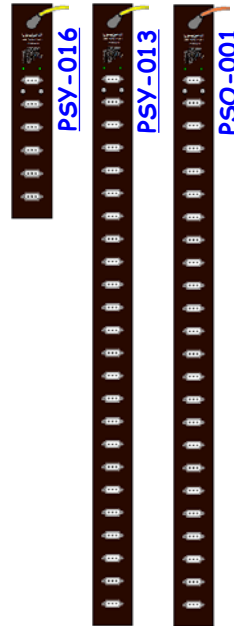

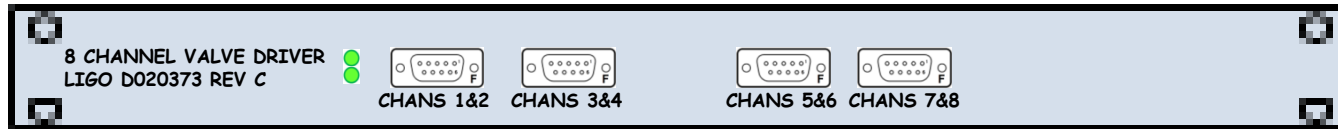

D020373

Front

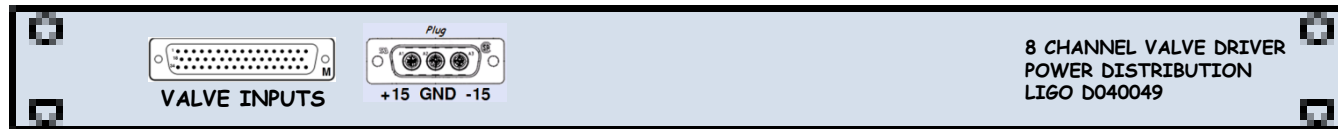
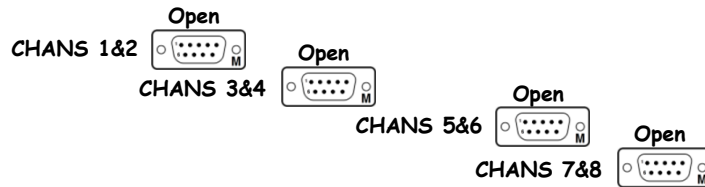

S1001155
D040049

Rear



I/O Extension Chassis

D1001715

SN

24 VDC



D1001715

Front

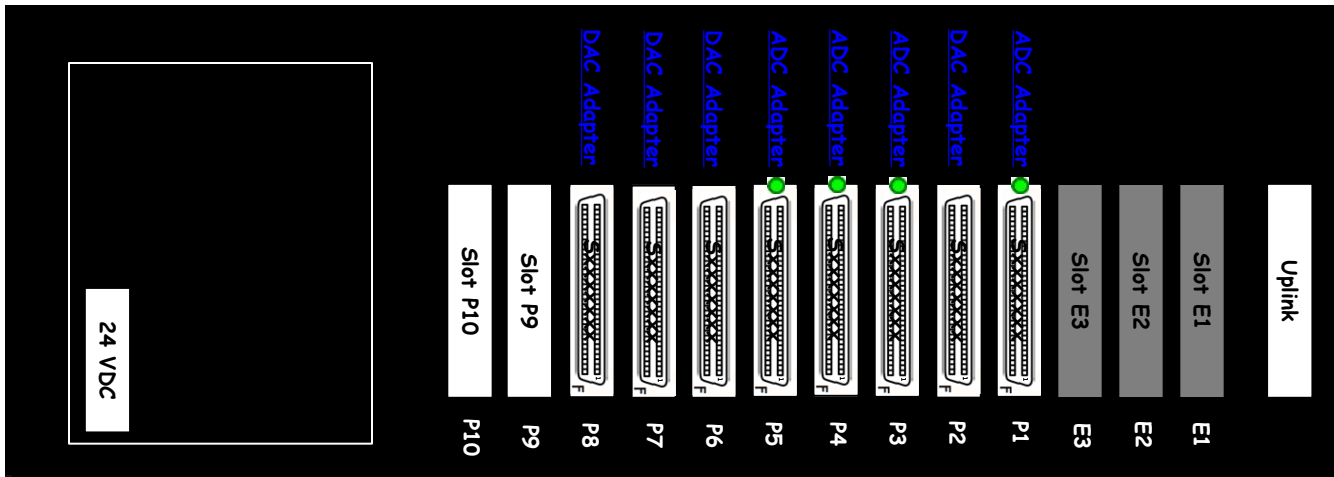

SN

Rear

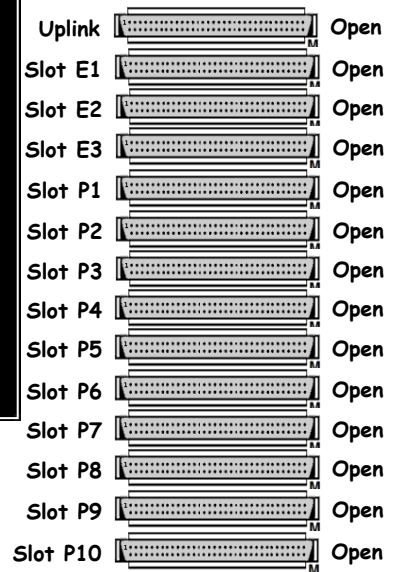

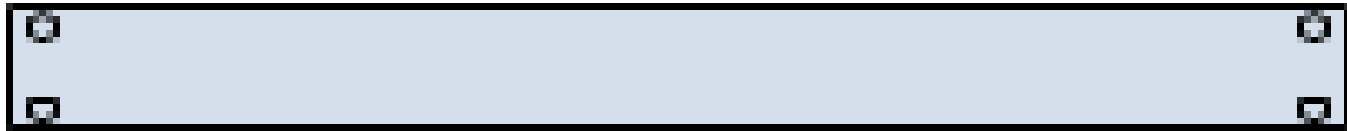

D1102206

Front

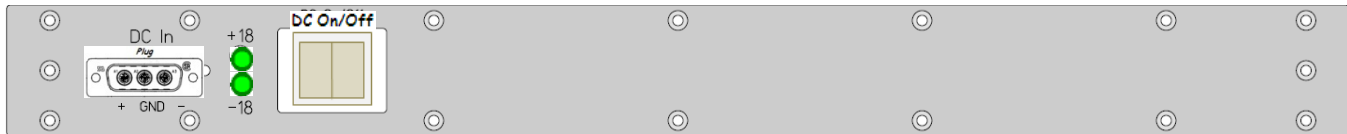

S???????

Rear

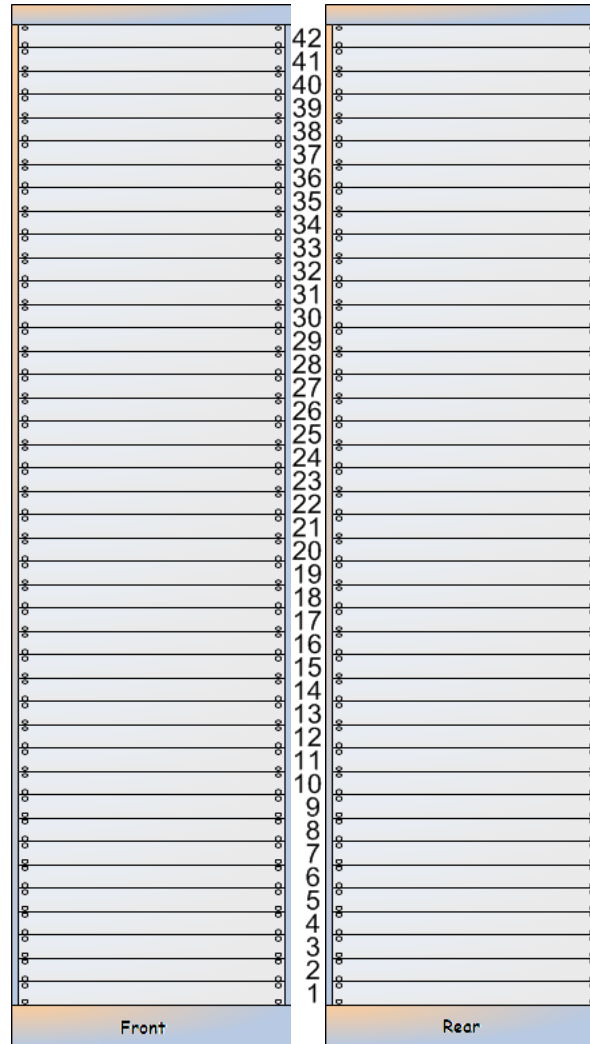

| | |
|--------|----|
| +18VDC | ?A |
| -18VDC | ?A |
| +24VDC | ?A |

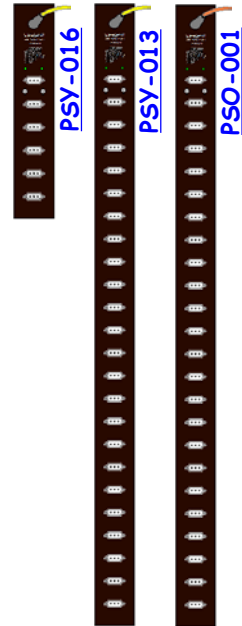

L1-TCS-YR1

TCS <Y> Rack Layout (LIGO-Dxxxxxxx)

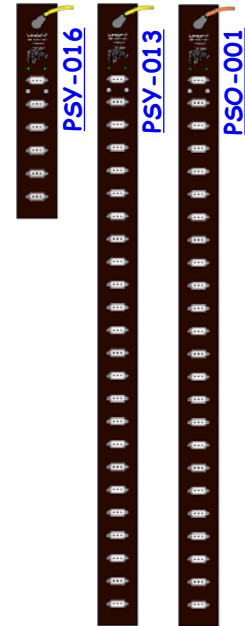
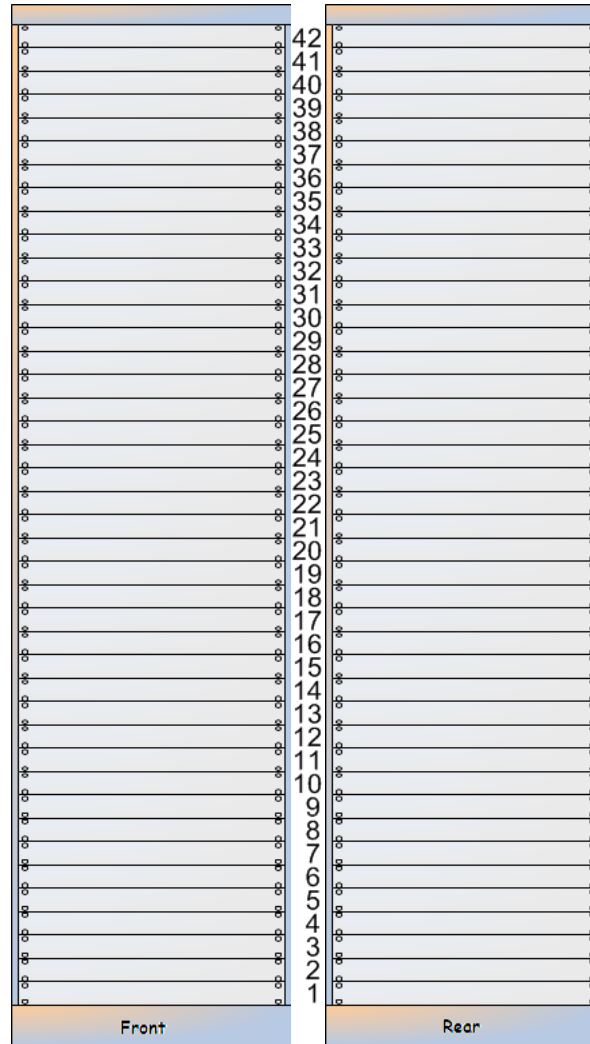

| | |
|--------|----|
| +18VDC | ?A |
| -18VDC | ?A |
| +24VDC | ?A |

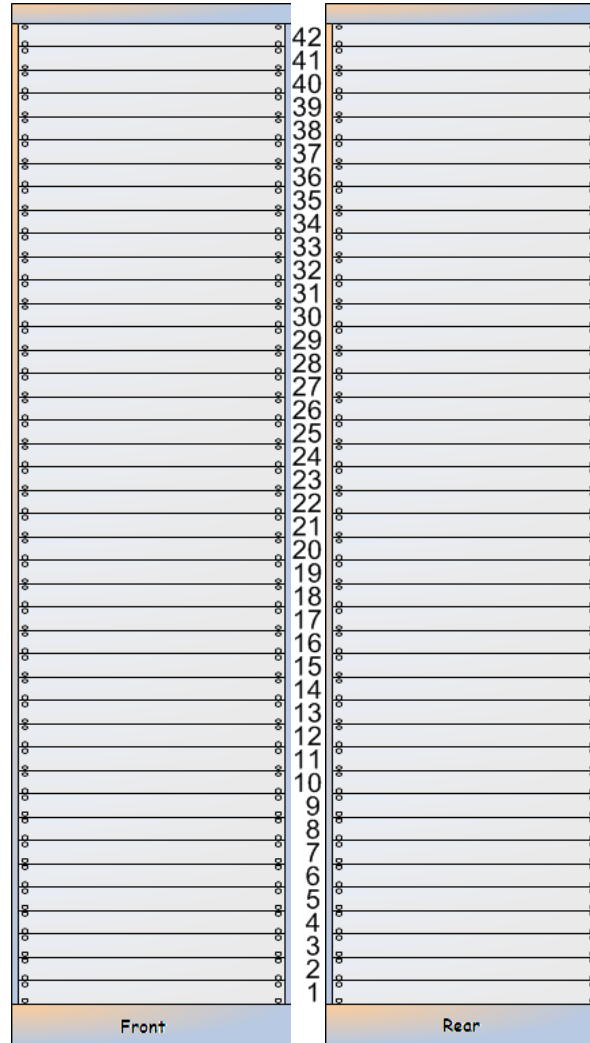

| | |
|--------|----|
| +18VDC | ?A |
| -18VDC | ?A |
| +24VDC | ?A |

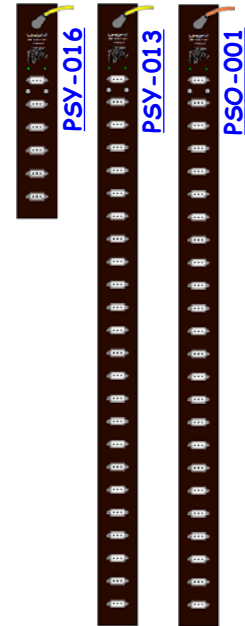

[<< LLO Map](#)

[<< LLO Racks by AREA](#)

[<< LLO CDS Components](#)

| | | |
|--|--|--|
| DAQ (aka CDS) Test Rack (L1-ETR-01) | RMS (aka Triple) Test Rack (L1-ETR-04) | Triple SUS Test Rack (L1-ETR-07) |
| BSC (aka QUAD) Test Rack (L1-ETR-02) | HAM ISI Test Rack (L1-ETR-05) | Future Test Rack (L1-ETR-08) |
| Optics Test Rack (L1-ETR-03) | STS Huddle Test Rack (L1-ETR-06) | Future Test Rack (L1-ETR-09) |

L1 DTS - IO

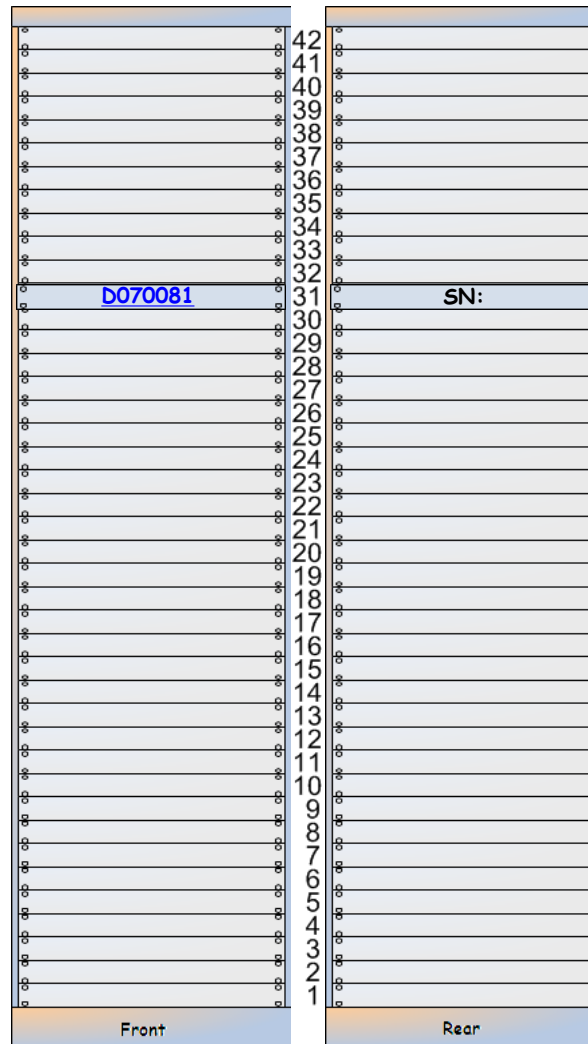
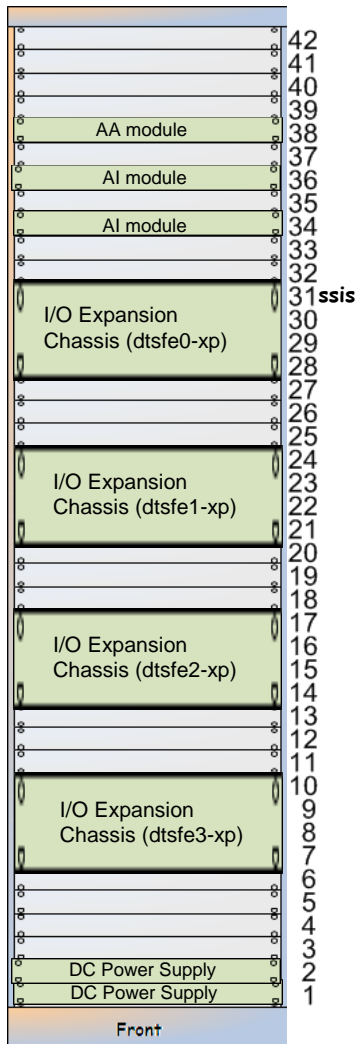

D070124 Rack Input
Power Box (RU 34-36)

$\pm 18 @ 0.5A$

| | |
|--------|----|
| +18VDC | ?A |
| -18VDC | ?A |
| +24VDC | ?A |
| -24VDC | ?A |

Front

Front

Rear

L1-ETRO1 DAQ (aka CDS)

L1-ETRO1
Front

Linksys BEFSX41
Firewall Router
D070011 Fanout Timing
Netgear GS724T Switch
Netgear GSM7352S Switch
SUN Microsystems X2200
SuperMicro



I/O Extension
2 ADC
1 DAC
1 Timing Slave
Shelf
KVM

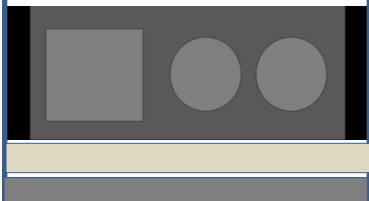

D070081 AI Chassis
D070081 AA Chassis

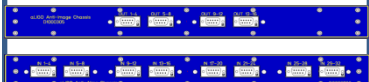

SuperMicro
SuperMicro
SuperMicro



JQE25-10M +15V
JQE25-10M -15V

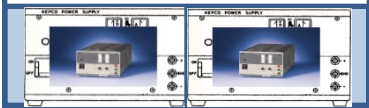

JQE25-10M +24V
JQE25-10M -24V

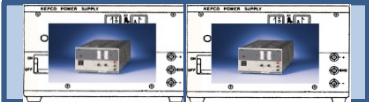

L1-ETRO1
Rear

D070011 Fanout Timing
SN:
SN:
0923QAT00D dtserver 192.168.100.10
... dtsfe1 192.168.100.15

DC Bus Distribution Box

Shelf
SN:
D070081 SYYYYYYYY
D070081 SYYYYYYYY
... dtstdco 192.168.100.30
... dtswfo 192.168.100.31
... dtsndso 192.168.100.32

SN:
SN:

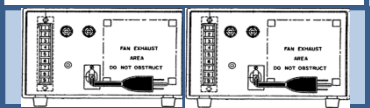

SN:
SN:

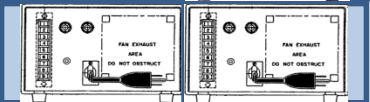

Linier Rack – has front and rear doors and wheels.

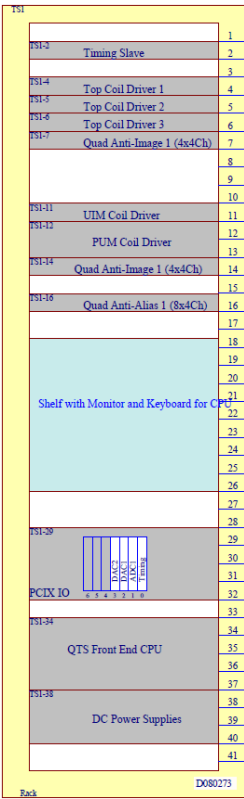

D070124 Rack Input Power Box (RU 34-36)

| | |
|--------|----|
| +18VDC | ?A |
| -18VDC | ?A |
| +24VDC | ?A |
| -24VDC | ?A |



L1-ETRO2
Front

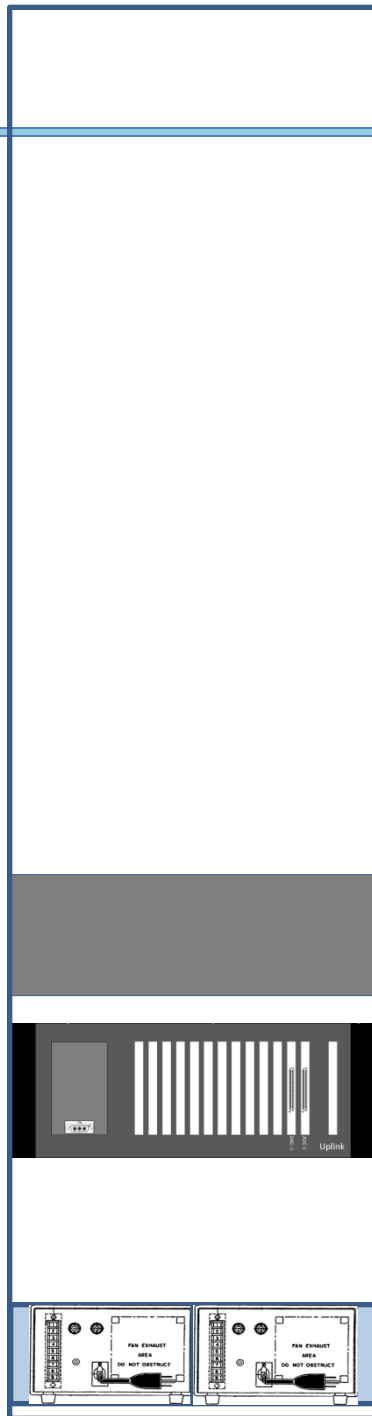
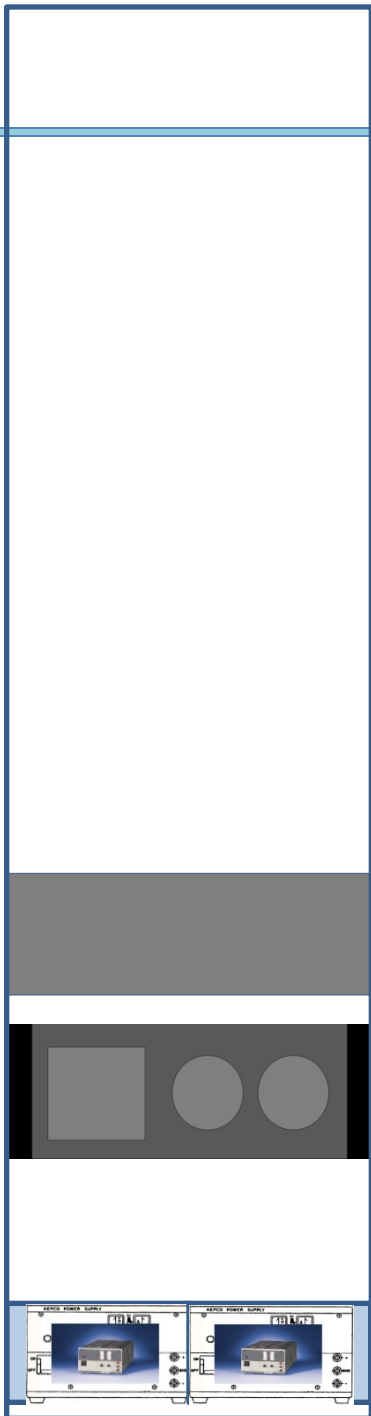

L1-ETRO2 BSC (aka Quad)

L1-ETRO2
Rear

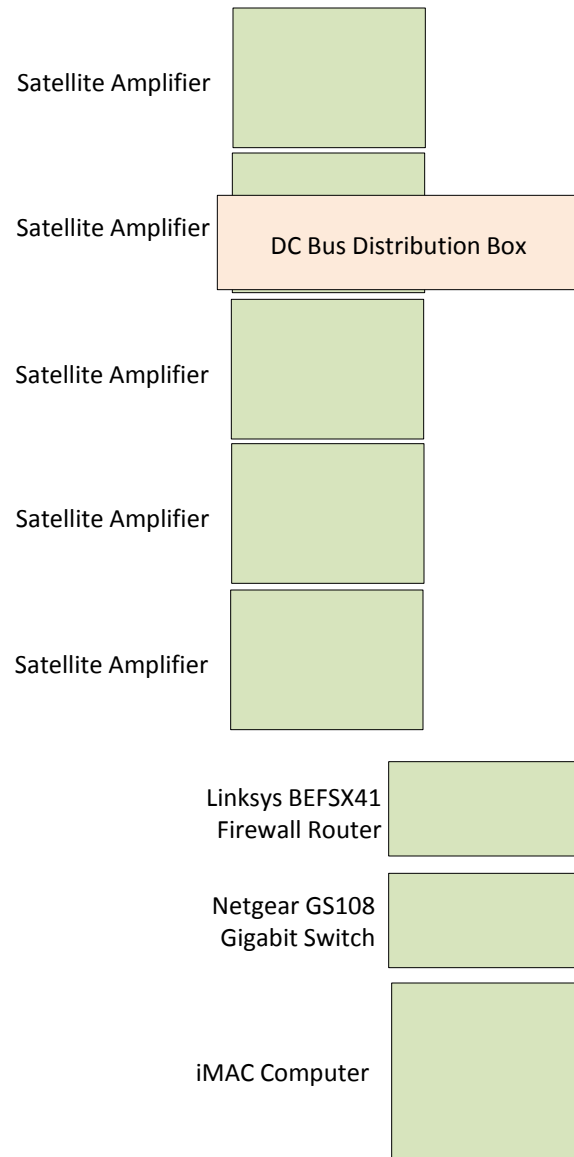



D070124 Rack Input
Power Box (RU 34-36)

| | |
|--------|----|
| +18VDC | ?A |
| -18VDC | ?A |
| +24VDC | ?A |
| -24VDC | ?A |

L1-ETRO3
Front

L1-ETRO3
Rear

Computer

I/O Extension
2 ADC
1 DAC
1 Timing Slave



SN:



Linksys BEFSX41
Firewall Router



Netgear GS108
Gigabit Switch



iMAC Computer

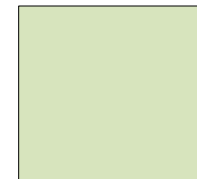

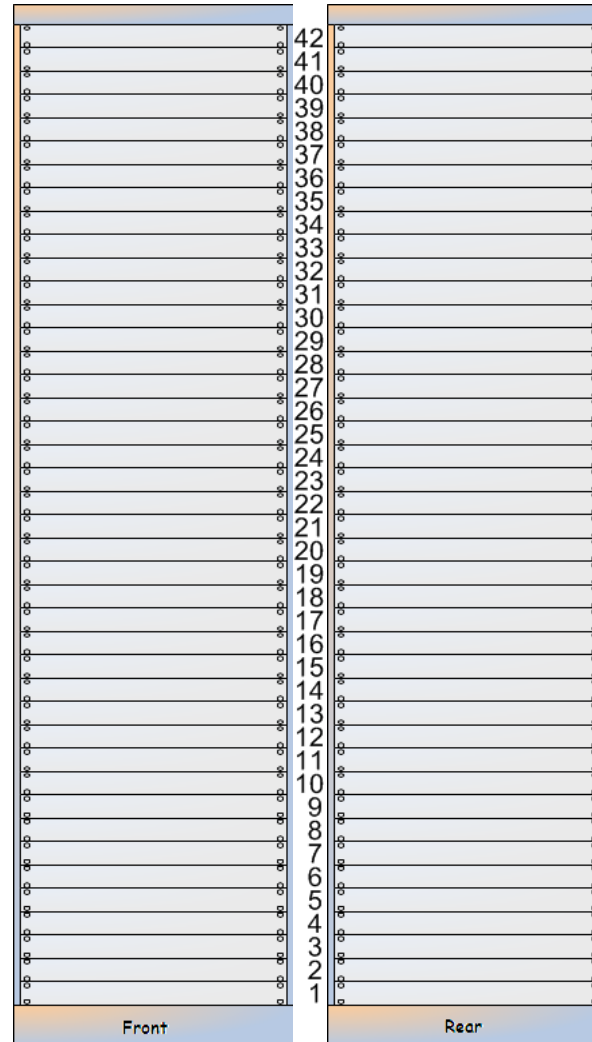

D070124 Rack Input Power Box (RU 34-36)

| | |
|--------|----|
| +18VDC | ?A |
| -18VDC | ?A |
| +24VDC | ?A |
| -24VDC | ?A |



L1-ETRO4 RMT (aka Triple)

L1-ETRO4
Front

L1-ETRO4
Rear

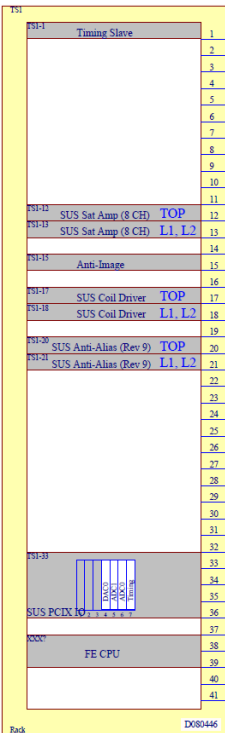

D1000305 AI Chassis

D1000305 SYYYYYYYY

D0902783 AA Chassis

D0902783 SYYYYYYYY

D0902783 AA Chassis

D0902783 SYYYYYYYY

Computer

SN:

I/O Extension

2 ADC

1 DAC

1 Timing Slave

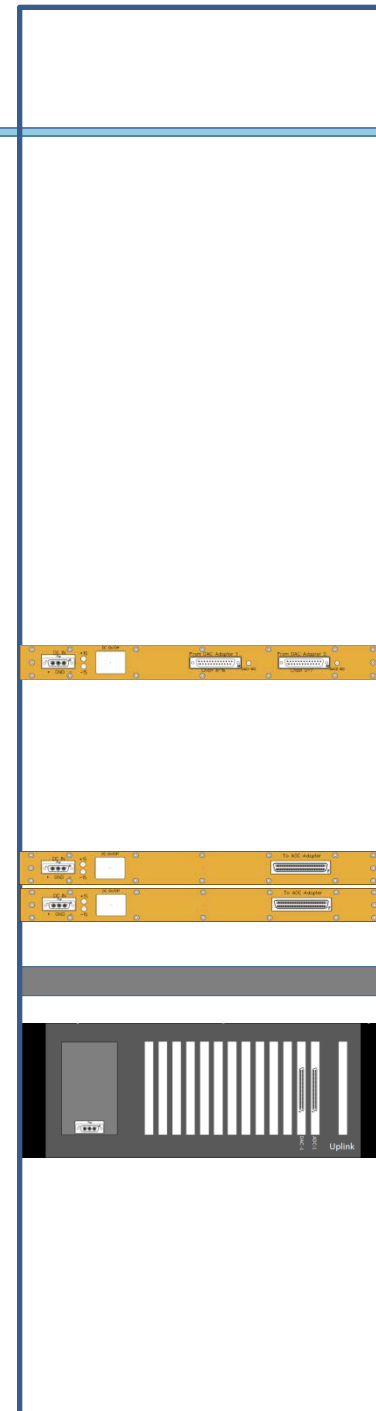
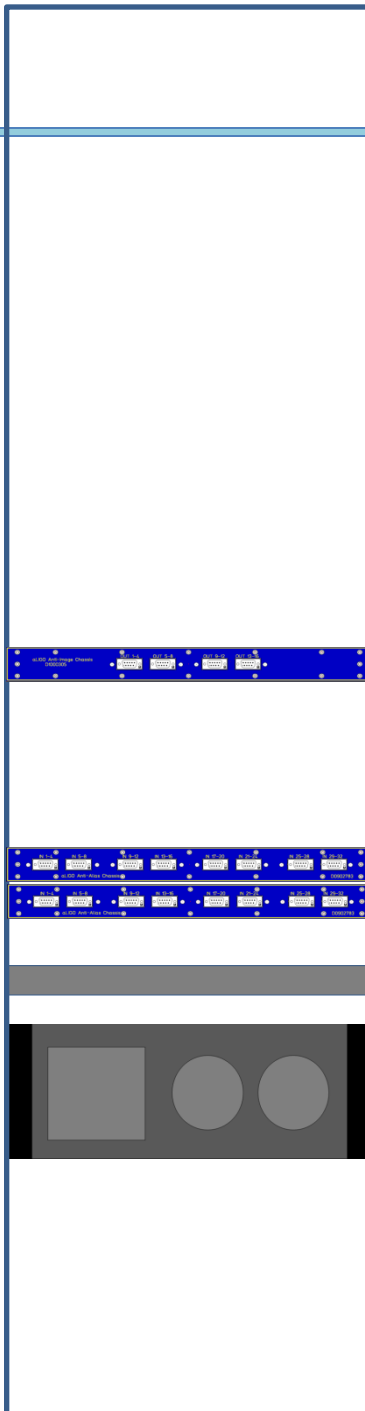
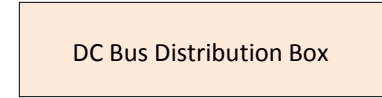

Linksys BEFSX41
Firewall Router



Netgear GS108
Gigabit Switch



iMAC Computer





**D070124 Rack Input
Power Box (RU 34-36)**

| | |
|--------|----|
| +18VDC | ?A |
| -18VDC | ?A |
| +24VDC | ?A |
| -24VDC | ?A |



L1-ETRO5 HAM ISI

L1-ETRO5
Front

L1-ETRO5
Rear

ISI Interface Pod 1 & L4C
ISI Interface Pod 2 & L4C
ISI Interface Pod 3 & L4C

Anti-Alias (AA) Chassis

Anti-Alias (AA) Chassis

Anti-Image (AI) Chassis

ISI Coil Driver (Pod 1 and 2)

ISI Coil Driver (Pod 3)

D1000067 S1000311
D1000067 S1000312
D1000067 S1000314

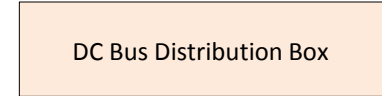

DC Bus Distribution Box

D1000269 S1000244

D1000269 S1000298

D070081 SS1000251

D0902744 S1000317

D0902744 S1000316

I/O Extension
2 ADC
1 DAC
1 Timing Slave
Computer



SN:

SN:

JQE25-10M +24V
JQE25-10M -24V

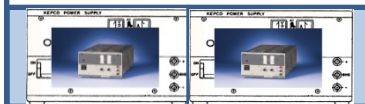

SN:

SN:

JQE25-10M +15V
JQE25-10M -15V

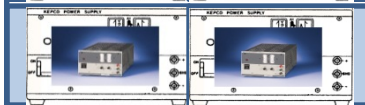

SN:

SN:

iMAC Computer

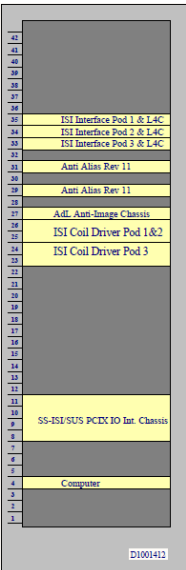
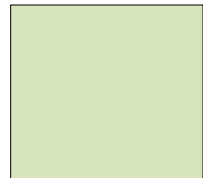

D1001412

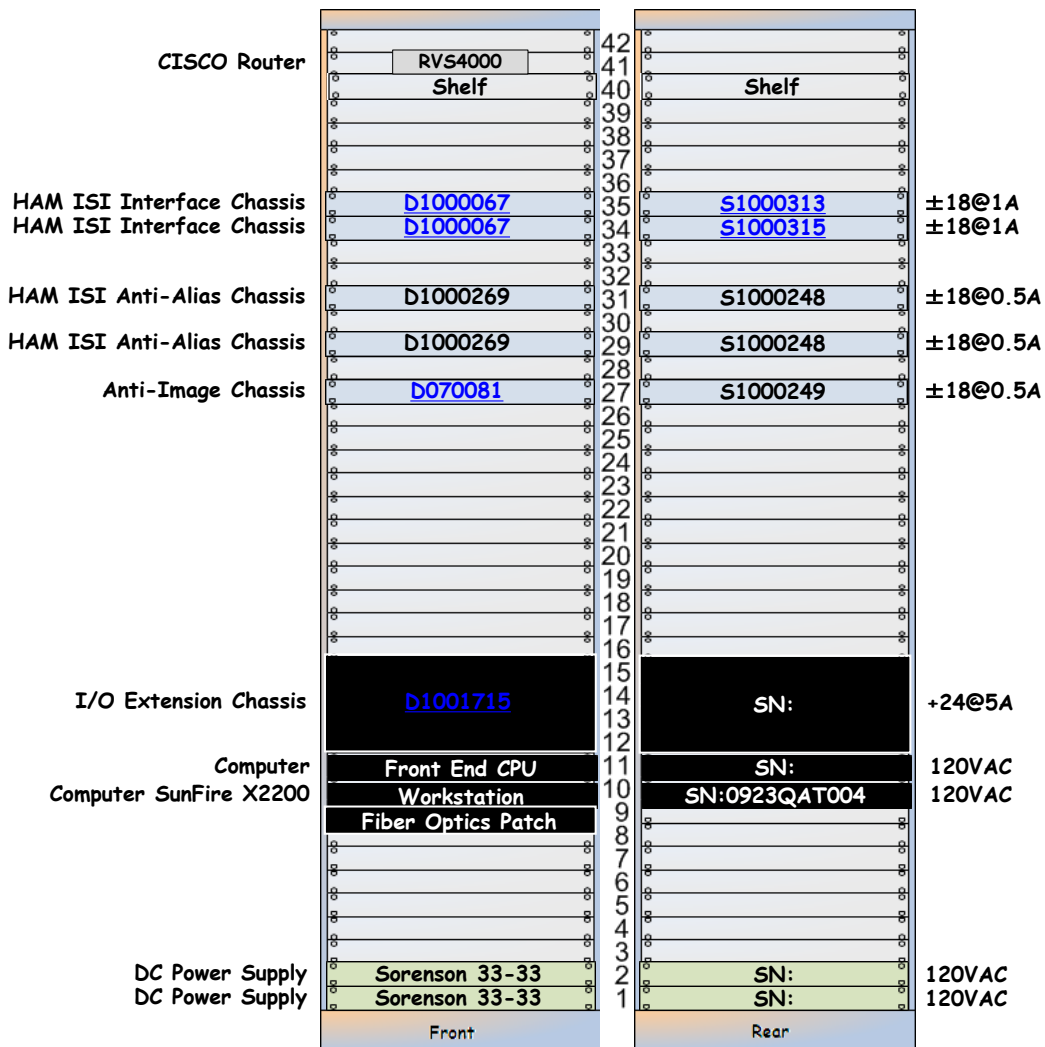

D070124 Rack Input Power Box (RU 34-36)

0 - ADC0
1 - DAC0
2 - ADC1

| | |
|--------|----|
| +18VDC | ?A |
| -18VDC | ?A |
| +24VDC | ?A |
| -24VDC | ?A |



L1-ETRO6
Front

L1-ETRO6
Rear

L1:ETRO6 STS Huddle

ISI Interface Pod 1 & L4C
Pod 2 & L4C
Pod 3 & L4C

DXXXXXXXXX SYYYYYYYYY
DXXXXXXXXX SYYYYYYYYY
DXXXXXXXXX SYYYYYYYYY

DC Bus Distribution Box

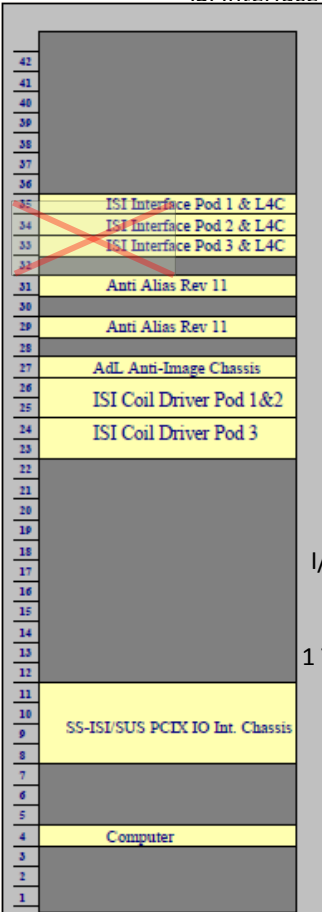

3 AA Chassis
3 AA Chassis
I/O Extension
2 ADC
1 DAC
1 Timing Slave
Computer

D0902783 SYYYYYYYYY
D0902783 SYYYYYYYYY

Linksys BEFSX41
Firewall Router

SN:

Netgear GS108
Gigabit Switch

iMAC Computer

SN:
SN:

5-10M +15V
5-10M -15V

D1001412

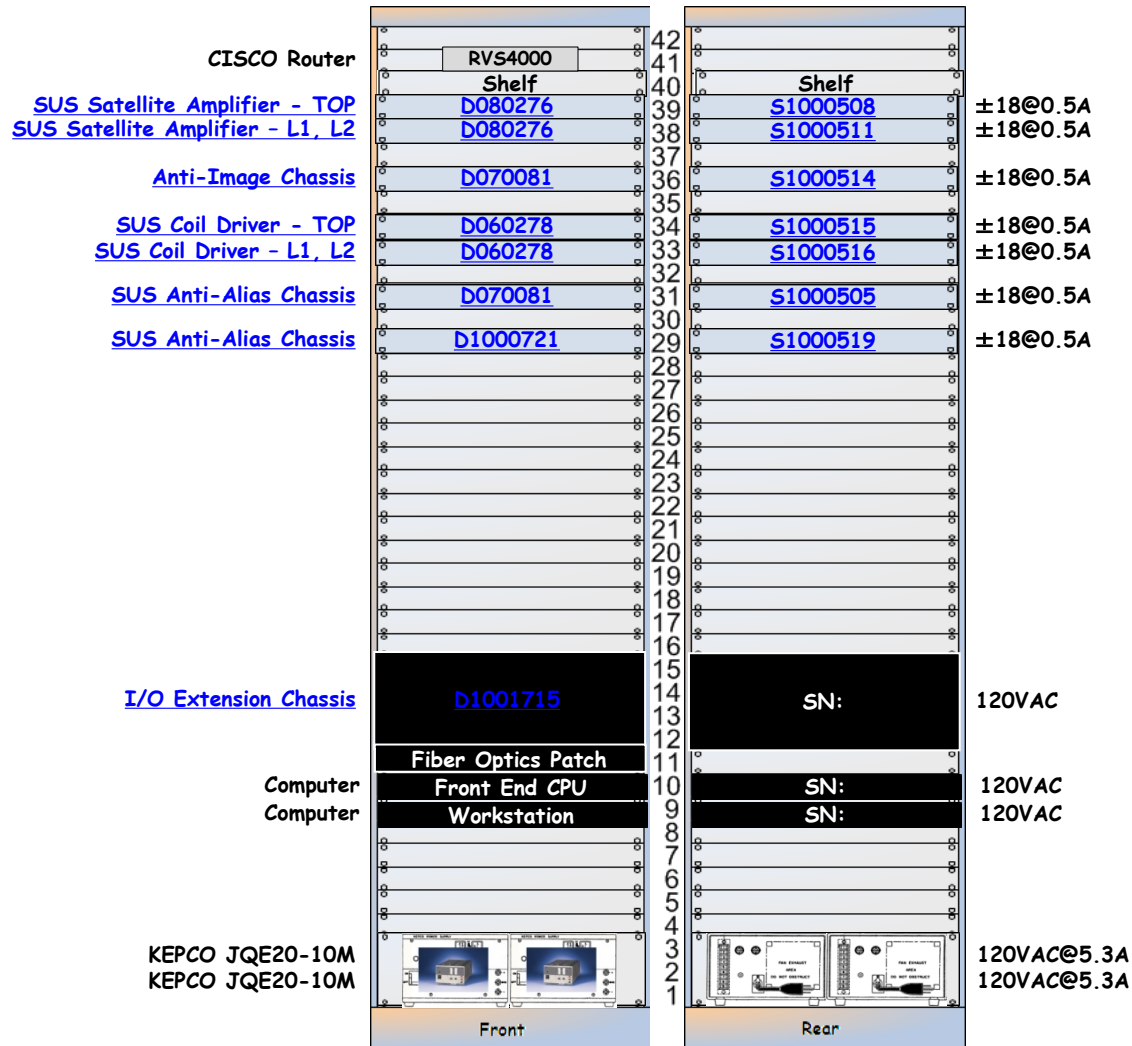

D070124 Rack Input Power Box (RU 34-36)

0 - ADC0
1 - DAC0
2 - ADC1

+18VDC 3A
-18VDC 2.7A

UM (Top)

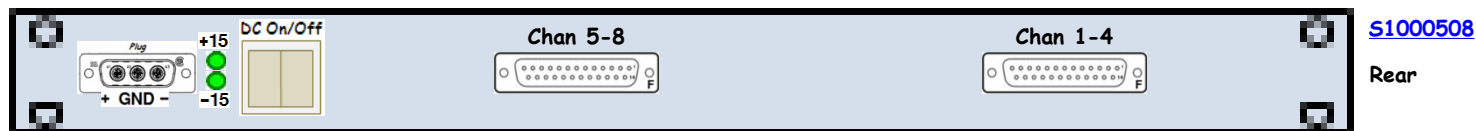
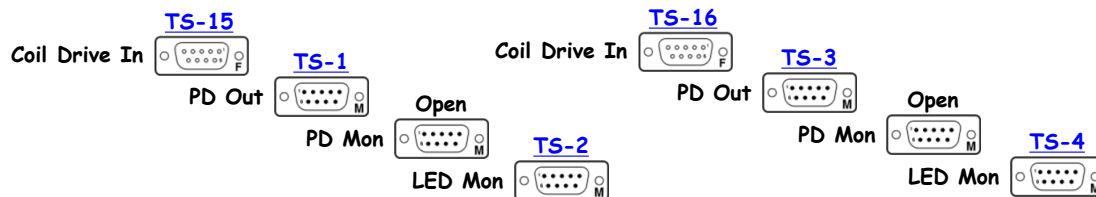

SUS Satellite Amplifier - L1, L2 D080276 S1000511 ±18@0.5A

IM (L1), BM (L2)

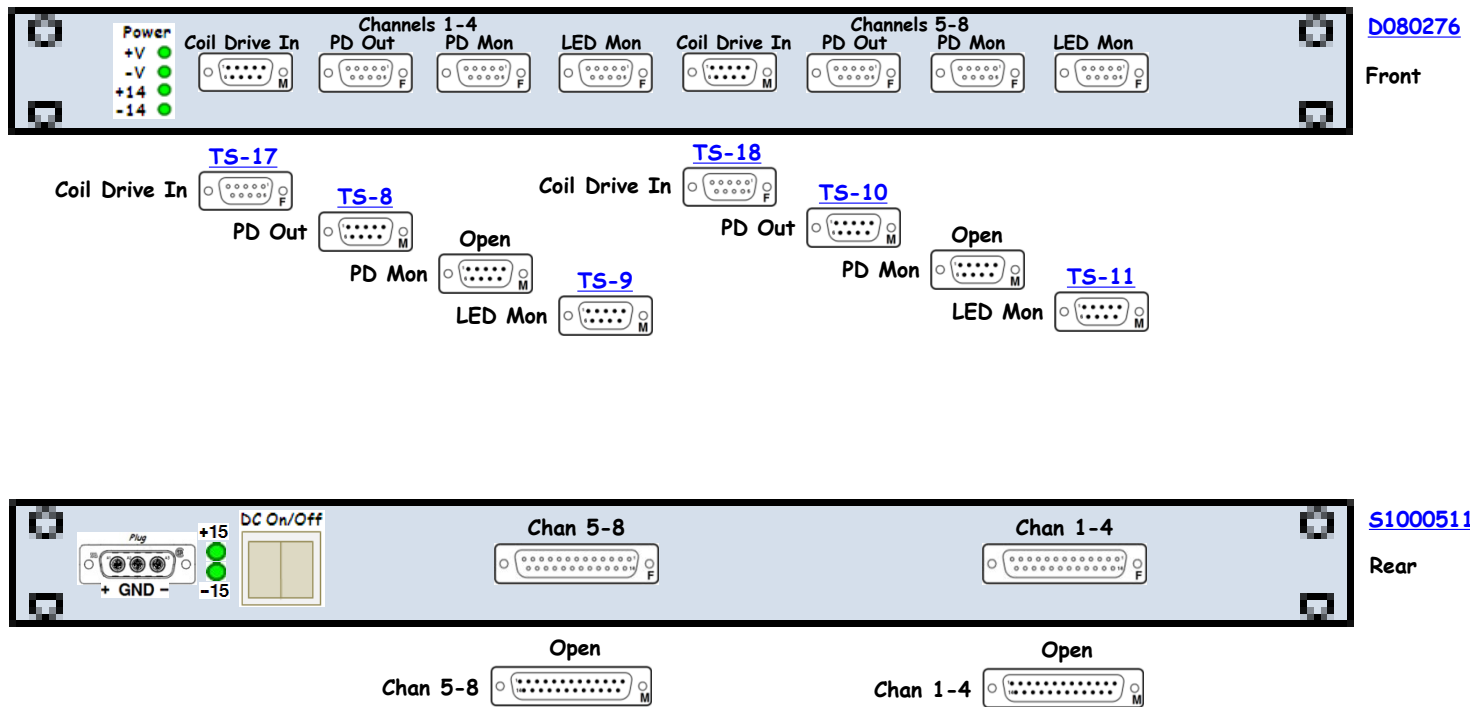

D080276

Front

S1000511

Rear

Anti-Image Chassis D070081 S1000514 ±18@0.5A

UNBUFFERED

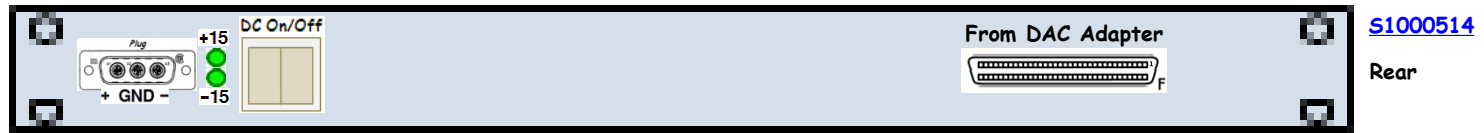

UM (Top)

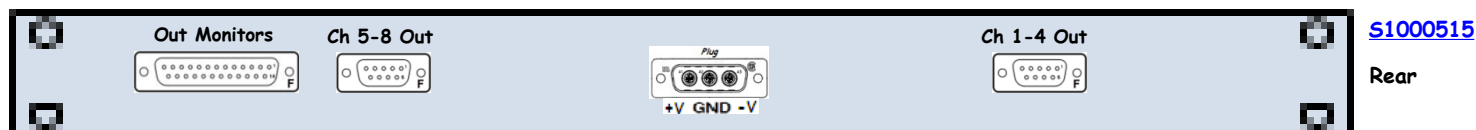
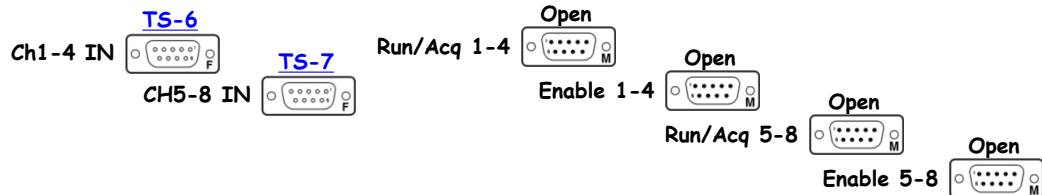
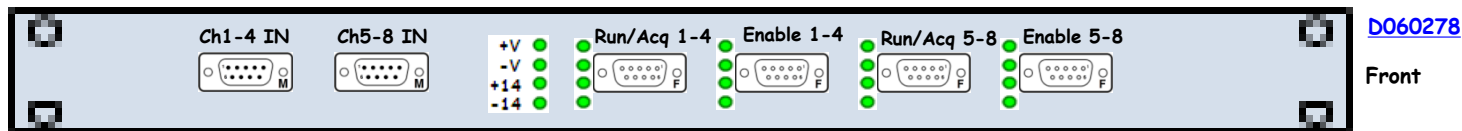

SUS Coil Driver - L1, L2 D060278 S1000516 ±18@0.5A

IM (L1), BM (L2)

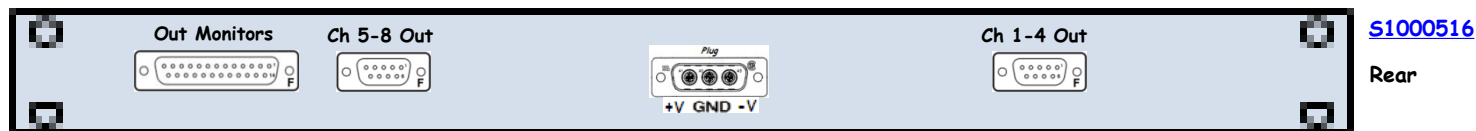
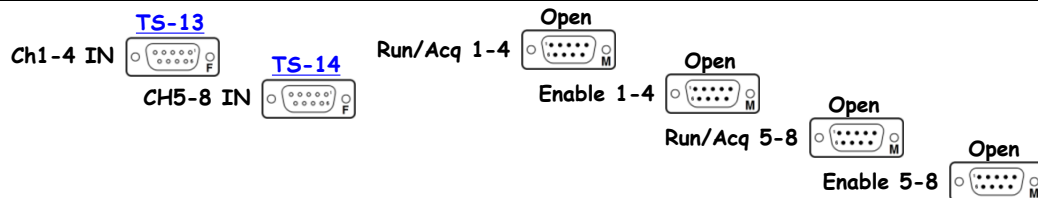
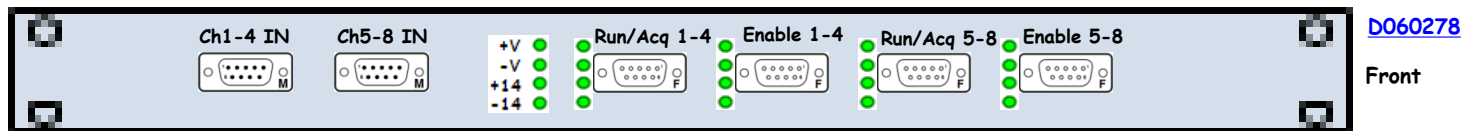

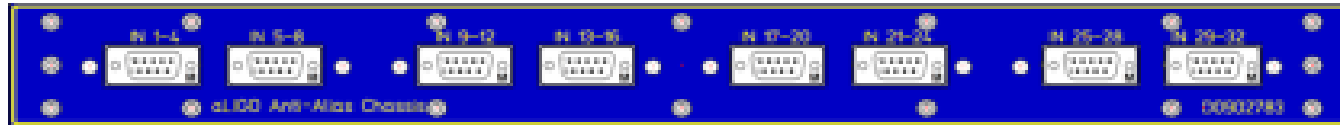

[D0902783](#)

Front

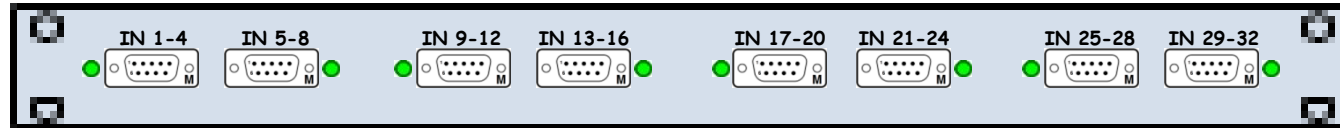

[D070081](#)

Front

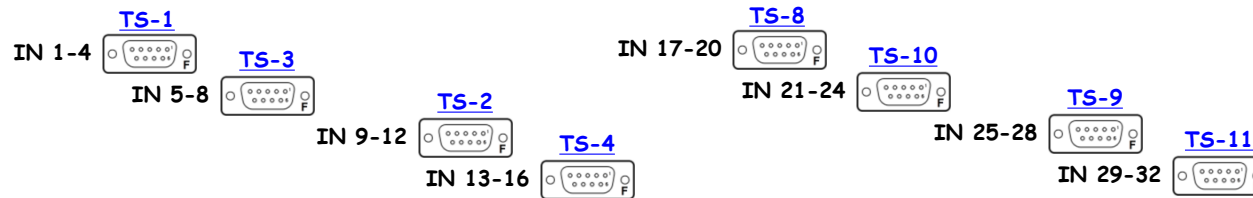

[S1000505](#)

Rear

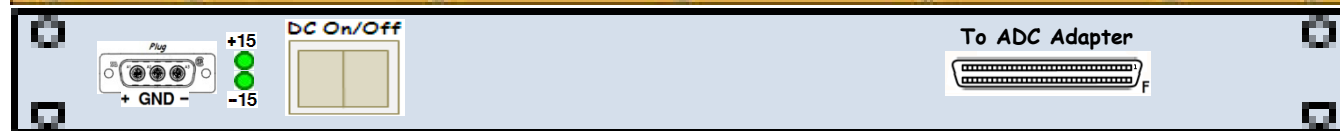

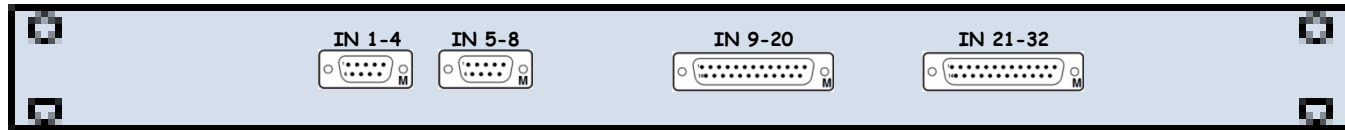

[D1000721](#)

Front

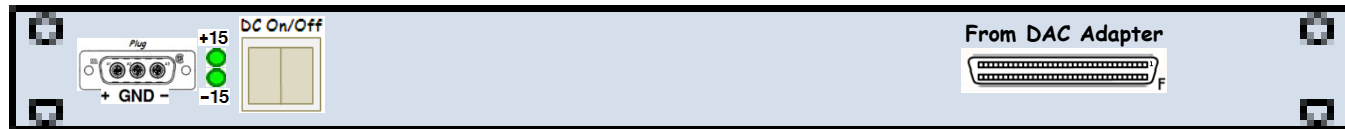

[S1000519](#)

Rear



D1001715-Sxxxxxxxx

I/O Extension Chassis

D1001715

SN

24 VDC



D1001715

Front

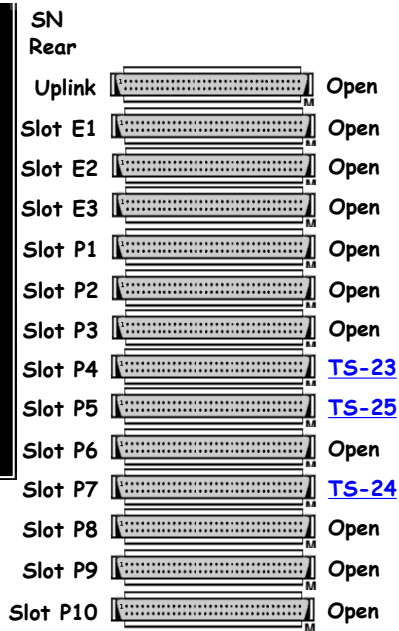
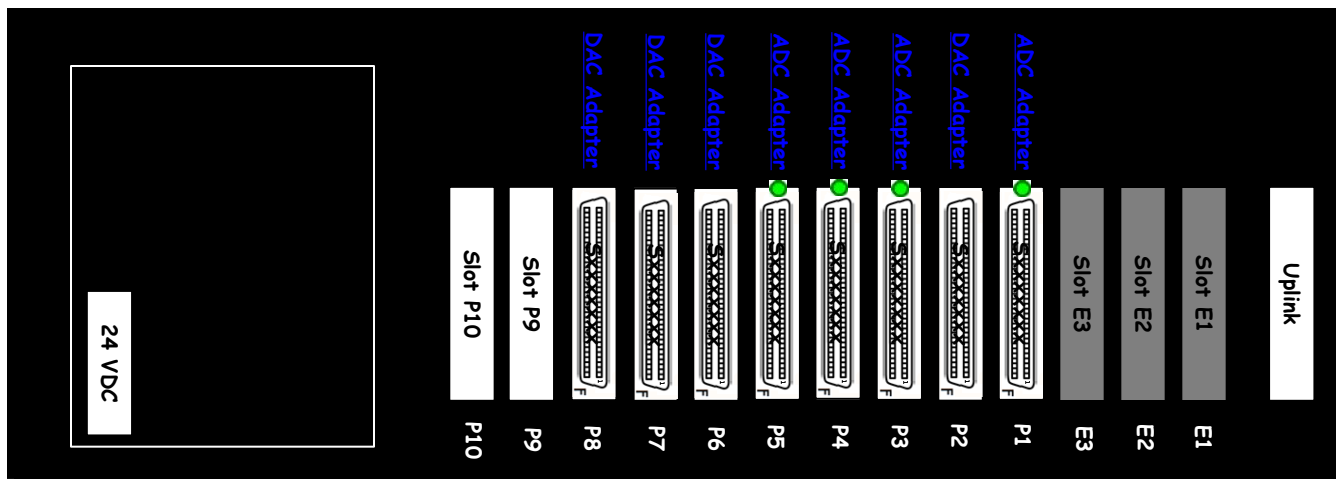

Templates

D070124 Rack Input
Power Box (RU 34-36)

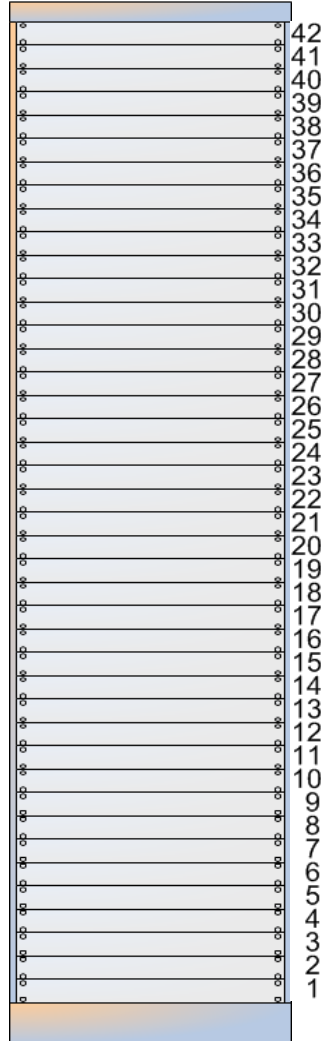
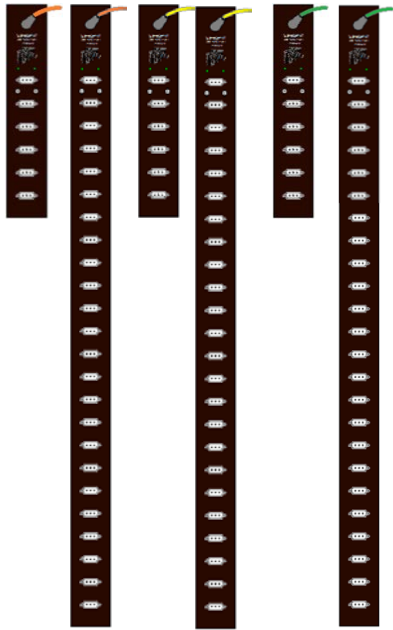

Description **Dxxxxxxx** **SN:** Power

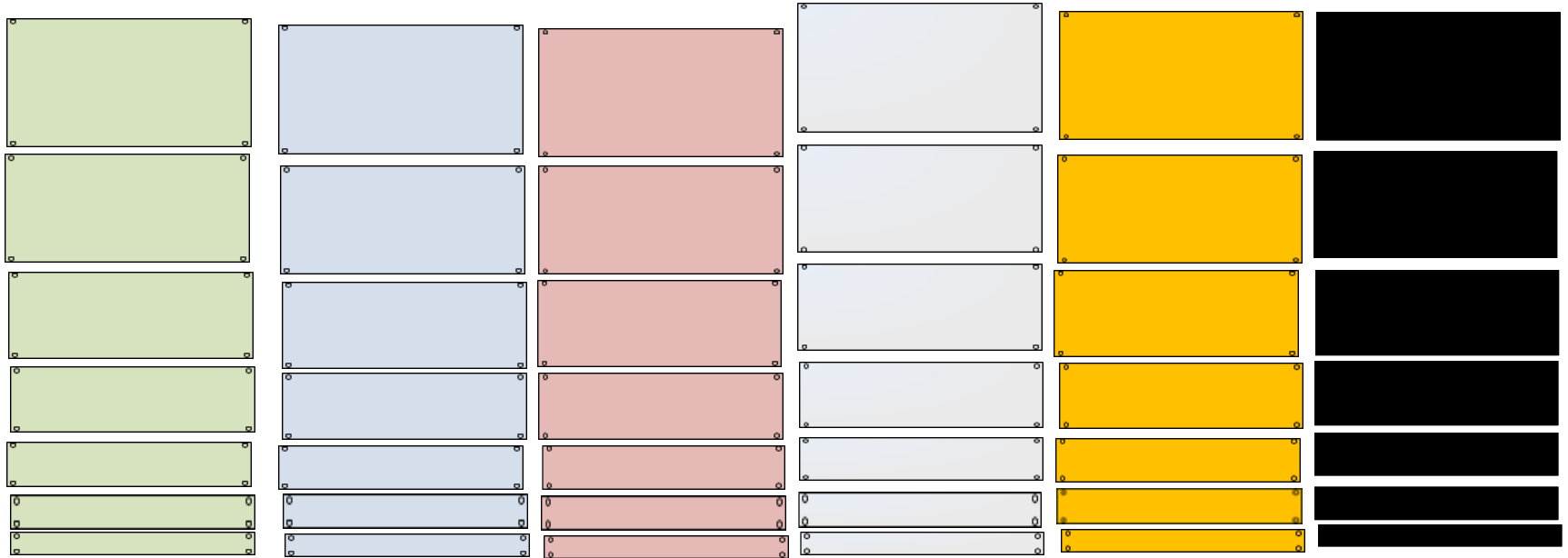

Description **Dxxxxxxx** **SN:** Power

Description Power

Description Power

Description Power

Description Power

Description Power

Description Power

Description Power

Description **Dxxxxxxx** **SN:** Power



Description Power

Description Power

Shelf

DE-9

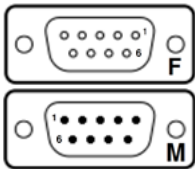

DA-15

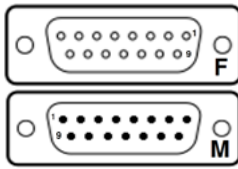

DB-25

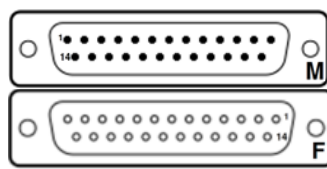

DC-37

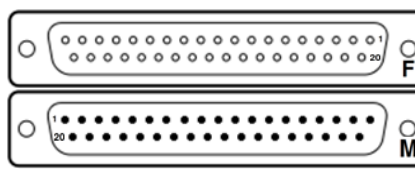

DD-50

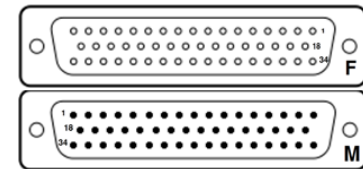

CP-4

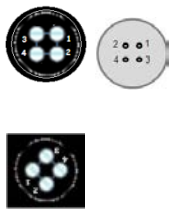

LEMO 2-Pin

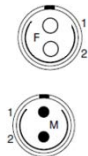

LEMO 4-Pin

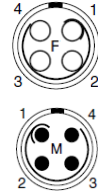

Conec

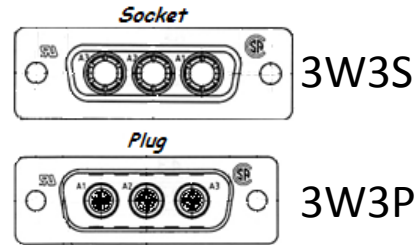

SCSI-68

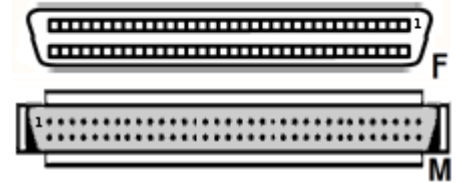

BNC

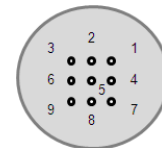

Conec

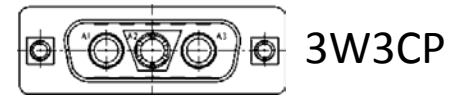
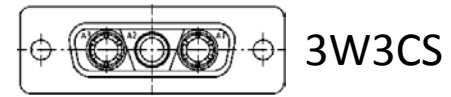
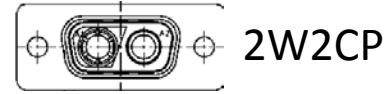
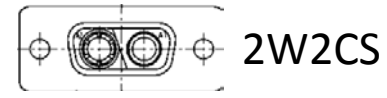
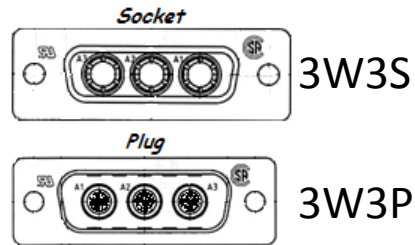

CP-4

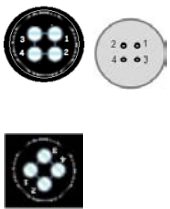

LEMO 2-Pin

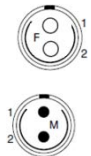

LEMO 4-Pin



+V -V Layouts

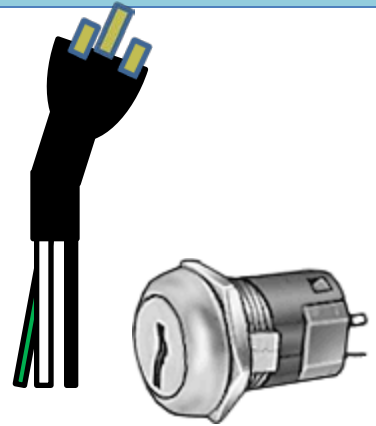

-V

+V

Power
 +V .
 -V .
 +14 .
 -14 .

Coil Driver Inputs

+V -V
 DC Power

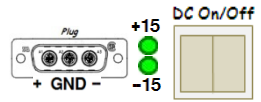

+ GND -

+V GND -V

+18

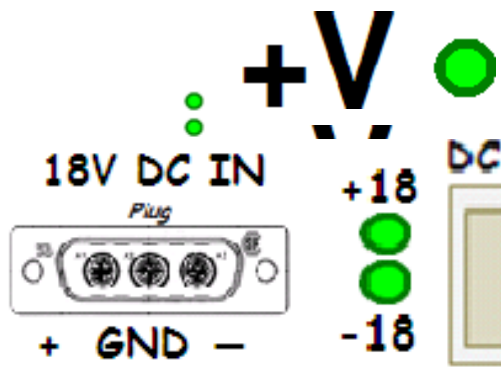

+24 GND -24

+18 GND -18

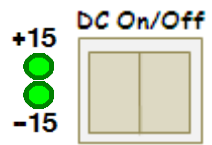

+V .
 -V .
 +14 .
 -14 .

+V

+V -V

-V

Power
 +V .
 -V .
 +14 .
 -14 .

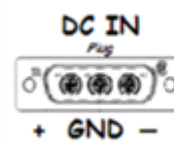
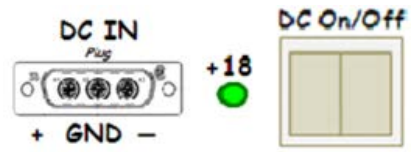

+15 GND -15

+V -V Layouts

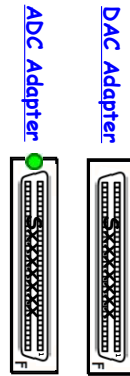

+V -V Layouts

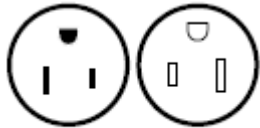

125 VAC, 15 Amps

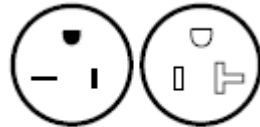

125 VAC, 20 Amps

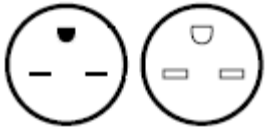

250 VAC, 15 Amps

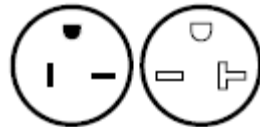

250 VAC, 20 Amps



L6-30R L6-30P

| VOLTAGE | NEMA | 15 AMPERE | | 20 AMPERE | | 30 AMPERE | | 50 AMPERE | | 60 AMPERE | |
|-----------------|------|------------|--------|------------|--------|------------|--------|------------|--------|------------|--------|
| | | Receptacle | Plug | Receptacle | Plug | Receptacle | Plug | Receptacle | Plug | Receptacle | Plug |
| 125 V | 1 | 1-15R | 1-15P | | | | | | | | |
| 250V | 2 | | 2-15P | 2-20R | 2-20P | 2-30R | 2-30P | | | | |
| 125V | 5 | 5-15R | 5-15P | 5-20R | 5-20P | 5-30R | 5-30P | 5-50R | 5-50P | | |
| 250V | 6 | 6-15R | 6-15P | 6-20R | 6-20P | 6-30R | 6-30P | 6-50R | 6-50P | | |
| 277V, A.C. | 7 | 7-15R | 7-15P | 7-20R | 7-20P | 7-30R | 7-30P | 7-50R | 7-50P | | |
| 125/ 250V | 10 | | | 10-20R | 10-20P | 10-30R | 10-30P | 10-50R | 10-50P | | |
| 3Ø 250V | 11 | 11-15R | 11-15P | 11-20R | 11-20P | 11-30R | 11-30P | 11-50R | 11-50P | | |
| 125/ 250V | 14 | 14-15R | 14-15P | 14-20R | 14-20P | 14-30R | 14-30P | 14-50R | 14-50P | 14-60R | 14-60P |
| 3Ø 250V | 15 | 15-15R | 15-15P | 15-20R | 15-20P | 15-30R | 15-30P | 15-50R | 15-50P | 15-60R | 15-60P |
| 3ØY 120/208V | 18 | 18-15R | 18-15P | 18-20R | 18-20P | 18-30R | 18-30P | 18-50R | 18-50P | 18-60R | 18-60P |

Security Cameras Layout

24VAC Power
To Camera

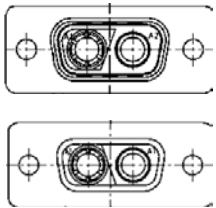

A1 = Black
A2 = White(Y) Red(X)

24VAC



110VAC

Signals To
Camera

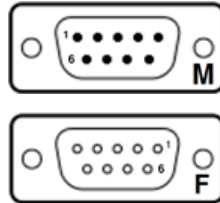

- 1 =
- 2 =
- 3 =
- 4 =
- 5 =
- 6 =
- 7 =
- 8 =
- 9 =

75 Ohm Signal
from Camera

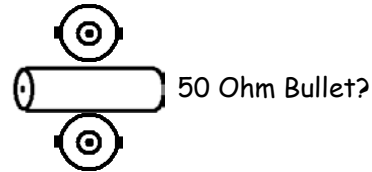

Interface

12VDC

Fiber Optics Connector Types



FC Ferrule Connector or
Fiber Channel



ST / BFOC Straight Tip / Bayonet Fiber
Optic Connector



LC Lucent Connector, or
Little Connector, or
Local Connector

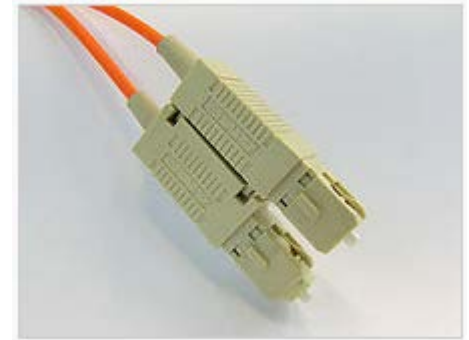

SC Subscriber Connector or
square connector or
Standard Connector

How Rack Documents Relate

