

8 7 6 5 4 3 2 1

NOTES: UNLESS OTHERWISE SPECIFIED

1. INTERPRET DRAWING PER ASME Y14.5-1994.
2. REMOVE ALL SHARP EDGES 0.005" to 0.015".
3. DO NOT SCALE FROM DRAWING.
4. ALL MACHINING FLUIDS MUST BE FULLY SYNTHETIC, FULLY WATER SOLUBLE AND FREE OF SULFUR, SILICONE, AND CHLORINE. REFER TO LIGO E0900237 FOR LIST OF APPROVED COOLANTS.
5. SCRIBE, ENGRAVE (A VIBRATORY TOOL MAY BE USED), LASER MARK OR MECHANICALLY STAMP (NO INKS OR DYES) DRAWING PART NUMBER, REVISION (AND VARIANT OR "TYPE" IF APPLICABLE) ON NOTED SURFACE OF PART FOLLOWED ON THE NEXT LINE WITH A THREE DIGIT SERIAL NUMBER. SERIAL NUMBERS START AT 001 FOR THE FIRST ARTICLE AND PROCEED CONSECUTIVELY. USE MINIMUM 0.12" HIGH CHARACTERS, UNLESS THE SIZE OF THE PART DICTATES SMALLER CHARACTERS.  
EXAMPLE: DXXXXXX-VY, TYPE-XX, S/N XXX
6. ALL PARTS SHALL BE MANUFACTURED IN ACCORDANCE WITH LIGO SPECIFICATION E0900364.
7. ALL MATERIAL IS TO BE VIRGIN MATERIAL (i.e. NO WELD REPAIRS, PLUGS OR RECYCLED MATERIAL). NO REPAIRS SHALL BE MADE UNLESS APPROVED IN ADVANCE, AND IN WRITING, BY LIGO LABORATORY. REFER TO LIGO-E0900364.

REV.	DATE	DCN #	DRAWING TREE #
v1	19 MAY 2011	E1000822-v1	-
-	-	-	-
-	-	-	-

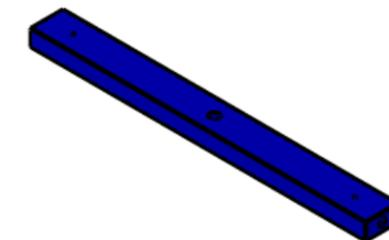

GENERAL VIEW  
FOR REFERENCE ONLY  
NO SCALE

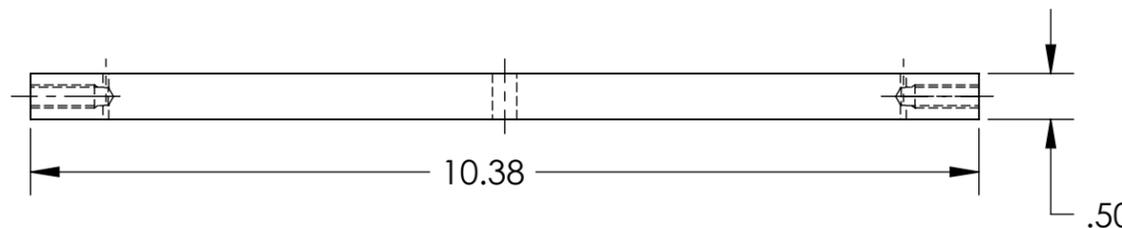
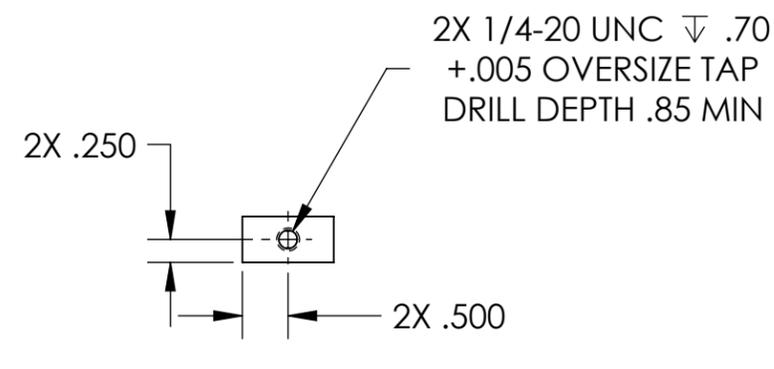
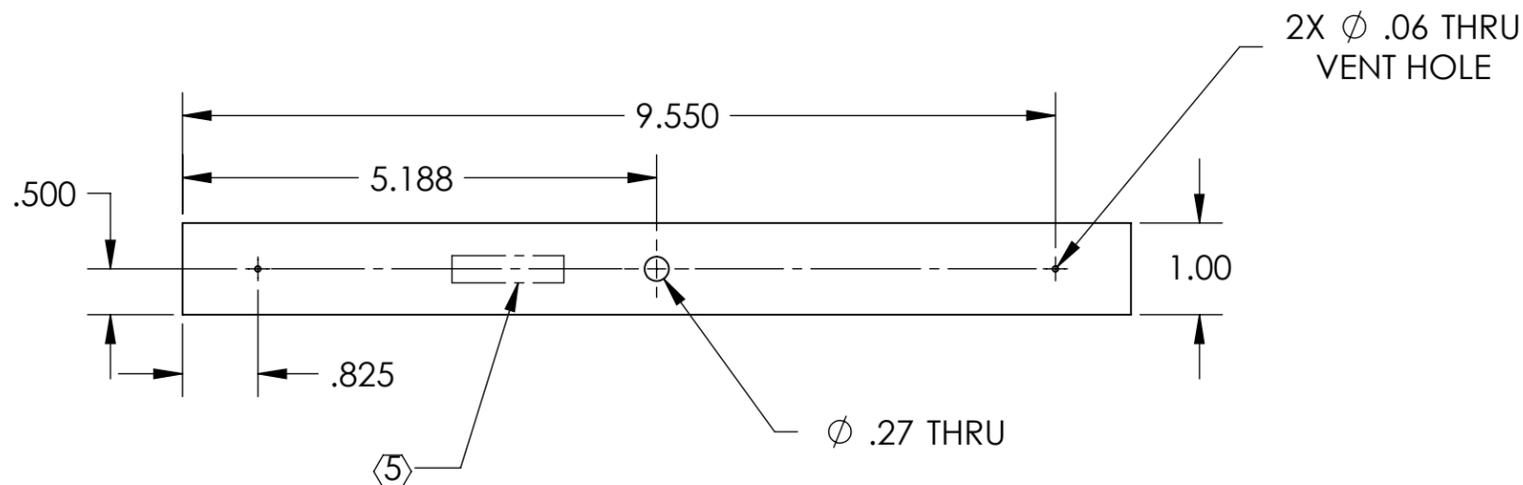

D1002871\_cllGO\_MC\_Tube\_Baffle\_Spoke, PART PDM REV: X-014, DRAWING PDM REV: X-012

NOTES AND TOLERANCES: (UNLESS OTHERWISE SPECIFIED)

DIMENSIONS ARE IN INCHES  
TOLERANCES:  
.XX ± .02  
.XXX ± .005  
ANGULAR ± 0.5°

MATERIAL 6061-T6 Al FINISH 63 μinch

**LIGO** CALIFORNIA INSTITUTE OF TECHNOLOGY  
MASSACHUSETTS INSTITUTE OF TECHNOLOGY

SYSTEM ADVANCED LIGO SUB-SYSTEM AOS

NEXT ASSY D1002864

PART NAME			TUBE BAFFLE SPOKE		REV.
DESIGNER	TQ. NGUYEN	28 OCT 2010	SIZE	DWG. NO.	v1
DRAFTER	TQ. NGUYEN	12 NOV 2010	<b>B</b>	<b>D1002871</b>	
CHECKER	M. SMITH		SCALE: 1:2	PROJECTION:	SHEET 1 OF 1
APPROVAL	D. COYNE				

8 7 6 5 4 3 2 1