

AM-Stabilized RF Amplifier Driver

SURF Project Final Report

August 2010

Jing Luo¹

Mentor: Daniel Sigg²

Co-Mentor: Paul Schwinberg³

Abstract:

The AOM/EOM driver is a high power RF amplifier used to drive an eletro-optic modulator [EOM] or an acousto-optic modulator [AOM] for Advanced LIGO. It provides up to 2W of RF power adjustable over a 24.2dB range, from 10 dBm to 34.2 dBm. It has an amplitude stabilization circuit to minimize the oscillator amplitude noise. The main structure of the present design consists of a radio frequency [RF] chain with a 12 dBm source input, a voltage-controlled attenuator, a high power amplifier and two in series directional couplers. For RF AM stabilization, there is an in-loop and an out-of-loop circuit. The in-loop circuit includes an RF detector, which is fed by the first coupler and connects an RF servo to control the voltage-controlled attenuator. This detector can accurately measure the RF noise and remove unwanted noise. The out-of-loop circuit has an independent RF detector to verify the AM noise after the stabilization.

¹ Hobart and William Smith Colleges, contact: jing.luo@hws.edu

² LIGO Hanford Observatory, contact: sigg_d@ligo-wa.caltech.edu

³ LIGO Hanford Observatory, contact: schwinberg@ligo.caltech.edu

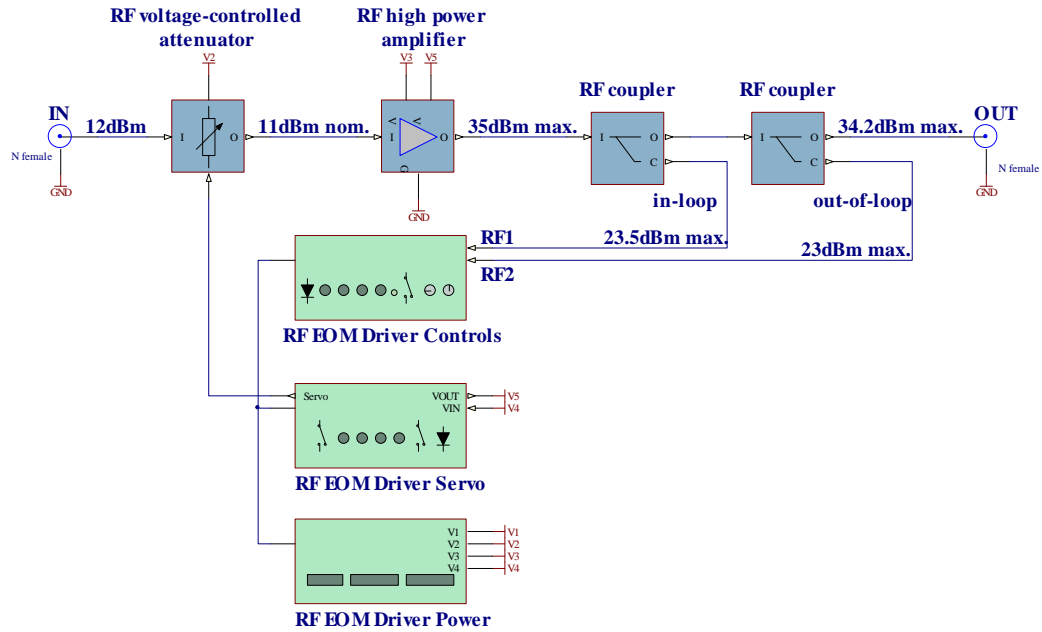

Figure 1: conceptual schematic

Conceptual Schematic:

- ◆ The RF chain consists of a 12 dBm source input, a voltage-controlled attenuator, a high power amplifier⁴, two in series directional couplers⁵ and provides up to 2W of RF power adjustable from 10 to 34.2 dBm.
- ◆ The RF EOM Driver board is controlled by a Field-Programmable Gate Array (FPGA) chip. It controls two identical RF detectors using front panel dials. The RF detectors measure the amplitude of the RF signal with high precision and low noise.
- ◆ For RF AM stabilization, there is an **in-loop** and an **out-of-loop** circuit.
 - The in-loop circuit includes an RF detector, which is fed by the first coupler (RF1) and connects to an RF servo to control the voltage-controlled attenuator. The feedback compensation network stabilizes the RF signal amplitude with a bandwidth up to 100 kHz.
 - The out-of-loop circuit is used as an independent RF detector, which is fed by the second coupler (RF2). It measures and verifies the AM noise after the stabilization.
- ◆ The power board is externally supplied with ± 17 and ± 31 VDC. The power board implements low noise voltage regulators for powering the other boards and modules.

⁴ RF high power amplifier (50Ω, 2W) requires less than 10dB input and has the gain of less than 29 dB

⁵ RF couplers have typical mainline loss of 0.65dB, and coupling ratio is 11.5±0.5 dB

Field-Programmable Gate Array (FPGA) Chip

The central control chip of the EOM Driver Module is a field-programmable gate array (FPGA), which allows us to design and run custom logic architectures without the need to manufacture a dedicated integrated circuit. The FPGA chip provides a powerful platform for running control software that can be manually reprogrammed to optimize the power output control algorithm. The chip used in the EOM Driver box is a Cool Runner II chip manufactured by Xilinx. We use Altium Designer with the Xilinx ISE to write and load FPGA software into the chip. This software sets the correct driver output based on a front panel dials and includes gain and polarity adjustment for the servo loop. It reads the excitation toggle switch and power amplifier on-off switch. The FPGA generates the digital control signals for setting output power using a logarithmic conversion table. It sends these signals to a digital-to-analog converter chip which outputs a bias voltage ranging from 0V to 10V. The bias voltage is then used by the in-loop RF detector.

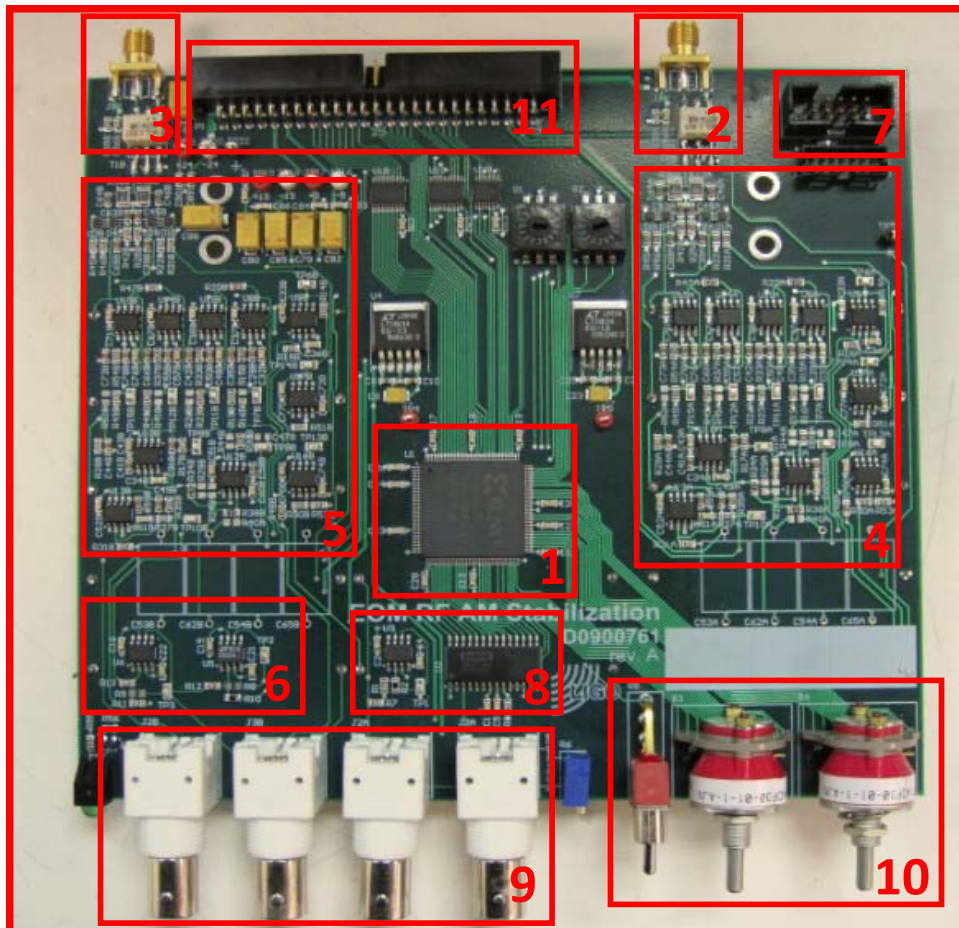

Figure 2: the EOM Driver Control Board. (1) FPGA chip. (2) RF1 input. (3) RF2 input. (4) In-loop detector. (5) Out-of-loop detector. (6) Out-of-loop automatic bias adjustment. (7) JTAG port for external programming of the FPGA. (8) Digital-to-analog converter chip. (9) Bias monitors. (10) Front panel dials. (11) Connection with the servo board and the power board.

RF Detector

The RF detector outputs an error voltage which is the difference between the desired RF power and the actual power. It has two inputs, one is a bias voltage (0V-10V) and the other is the actual RF signal from the RF coupler.⁶

The RF detector has a circuit which measures the V_{p-p} of an input RF signal and outputs this V_{p-p} as a DC voltage output. This DC voltage is then compared with the bias voltage. To minimize temperature drifts the bias current flows through diodes which are mounted inside the same physical package as the measurement diodes. The actual measurement circuit consists of two Shottky shunt diodes and two capacitors which act to measure the peak to peak amplitude of an input RF signal. In the figure below, we show the gain on a $2V_{p-p}$ RF signal input. The first shunt diode offsets the DC voltage of the RF signal. The second diode charges up a capacitor which acts as a low pass filter that removes the AC component of the RF signal. The output is then 2V, DC. This device is optimized to operate with high RF power to minimize Johnson noise and flicker noise.

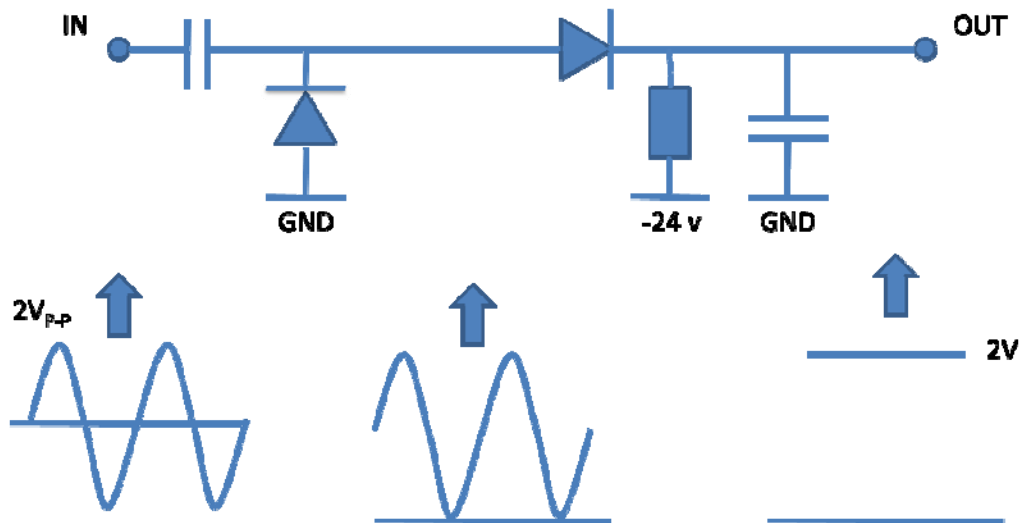

Figure 3: The RF detector V_{p-p} measurement circuit.

A transformer in front of the RF detector is used to double the voltage. Then, the V_{p-p} measurement circuit removes the AC component of the RF signal, and doubles its peak amplitude as a DC voltage. A second detector circuit is used with opposite diodes to make it a differential input stage. The detector then uses instrumentation amplifiers to compare the measured RF voltage with the bias voltage. The instrumentation amplifiers have a differential gain of 10. Finally, the difference of the two diode chains is sent to the servo board. When the actual RF level matches the target RF output set by the bias voltage, the RF detector maintains a zero output level.

⁶ For a complete circuit schematic of the RF detector, see Appendix A.

The in-loop circuit and the out-of-loop circuit use independent but identical RF detectors. For the in-loop circuit the RF input signal comes from the first coupler and the bias voltage is set by the digital-to-analog converter chip controlled by the FPGA. Each power level set by the user corresponds to a different bias voltage. Based on the error voltage the in-loop servo board sets a control voltage to change the attenuation of the voltage-controlled attenuator (upstream of the RF detector). This in turn keeps the error voltage near zero. Therefore, the output power level will be held at the desired level regardless of fluctuations in the input RF level.

The out-of-loop circuit⁷ measures the RF amplitude after the servo. It is therefore an independent measurement of the true performance of the AM stabilization circuit. The out-of-loop circuit uses automatic bias adjustment. The time constant of the automatic bias adjustment is slow. So, the error signal of the out-of-loop RF detector enables us to directly verify the amplitude noise on the output RF signal. The bias voltage can be used as an independent power measurement.

The ratio of the RF couplers is 11.5 dB. This means the maximum input to the RF detectors is 23.5 dBm. Figure 4 below shows the corresponding relationship between the bias voltage and the RF input signal. Since the in-loop detector and the out-of-loop detector are identical, the relationship between two detector inputs is the same. From the figure we can see a very good linear relationship.

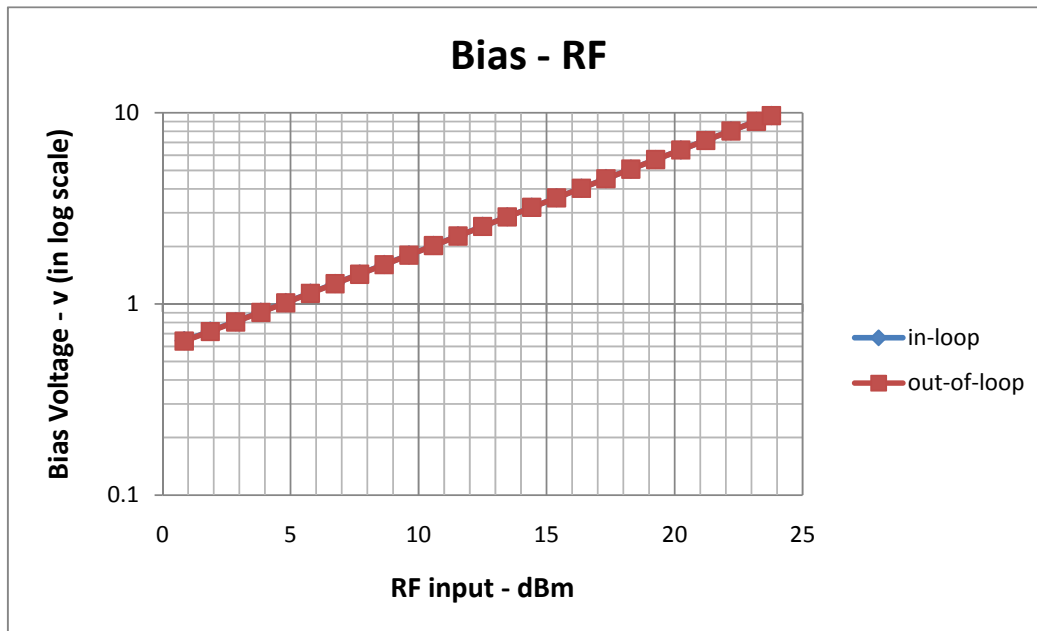

Figure 4: The relationship between two inputs of RF detector

⁷ For a complete circuit schematic of the out-of-loop servo, see Appendix A.

Figure 5 below shows the experimental result of each power output vs. the select power. The result shows that we can obtain a very good approximation of the desired output power level.

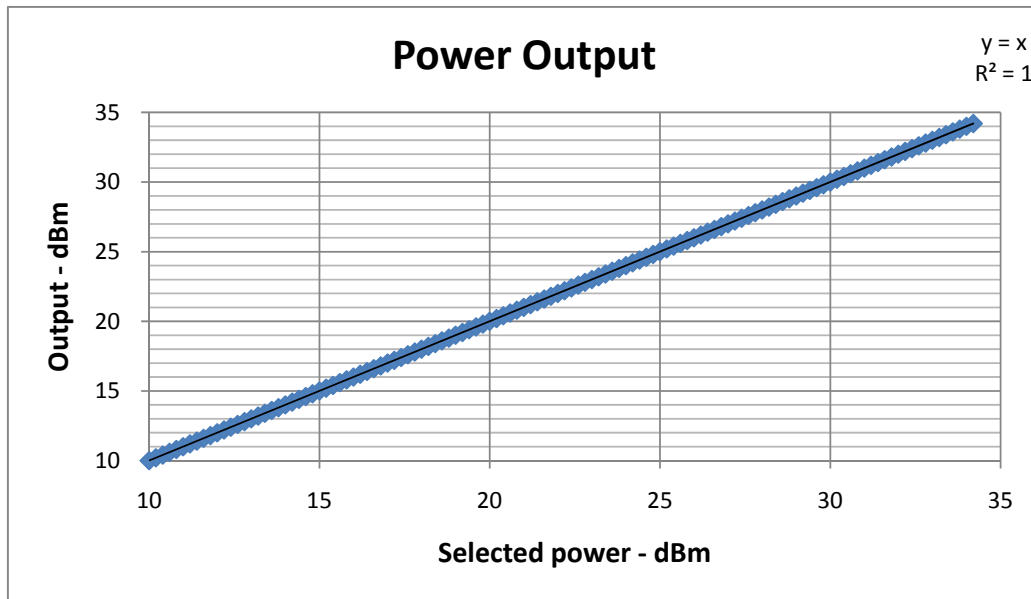

Figure 5: The relationship between power selected and the actual power output

Detector Sensitivity

In order to determine the detector sensitivity we measured the amplitude fluctuation at the error point in relation to the input as function of frequency and power level. We applied a modulation to the RF signal at the input of the detector to perform the measurement. The signal is then described by

$$A(t) = A \left(1 + \frac{\Delta A}{A} \cos(\omega t) \right) \cos(\Omega t)$$

which is equivalent to

$$A(t) = A \cos(\Omega t) + \frac{1}{2} \Delta A \cos(\Omega - \omega)t + \frac{1}{2} \Delta A \cos(\Omega + \omega)t$$

where Ω is the carrier frequency, A is the carrier amplitude, ω is the modulation frequency, and $\frac{1}{2} \Delta A$ is the sideband amplitude at $\Omega \pm \omega$. At the error point the carrier signal has been removed which leaves the modulation sidebands at frequency ω .

Table 1 below shows the sensitivity at different combination of RF frequency and output power level. We can see that the sensitivity is mostly independent of frequency and input power level.

	10MHz		21.5MHz		30MHz	
Output power	In-loop	Out-of-loop	In-loop	Out-of-loop	In-loop	Out-of-loop
10dBm	77.8	77.8	80.7	80.1	77.9	76.4
23.5dBm	77.9	77.9	81.7	80.4	78.4	77.9

Voltage-Controlled Attenuator

The voltage-controlled attenuator (Teledyne Cougar, GC2510) has a high attenuation range (greater than 35 dB) and is nearly frequency-independent in the bandwidth over which the EOM Driver Module operates. The servo board uses the attenuator to stabilize the RF signal. Moreover, the user can monitor the control voltage via a front panel output port.

Figure 6 shows the characteristic attenuation as function of frequency under several control voltages. Note that the EOM driver operates between 10MHz to 100MHz. Under proper operation conditions, the control voltage is between 2.5V and 7.5 V. This region of interest is shown in the red box. As we can see, the attenuation is frequency-independent under fixed control voltage in this area.

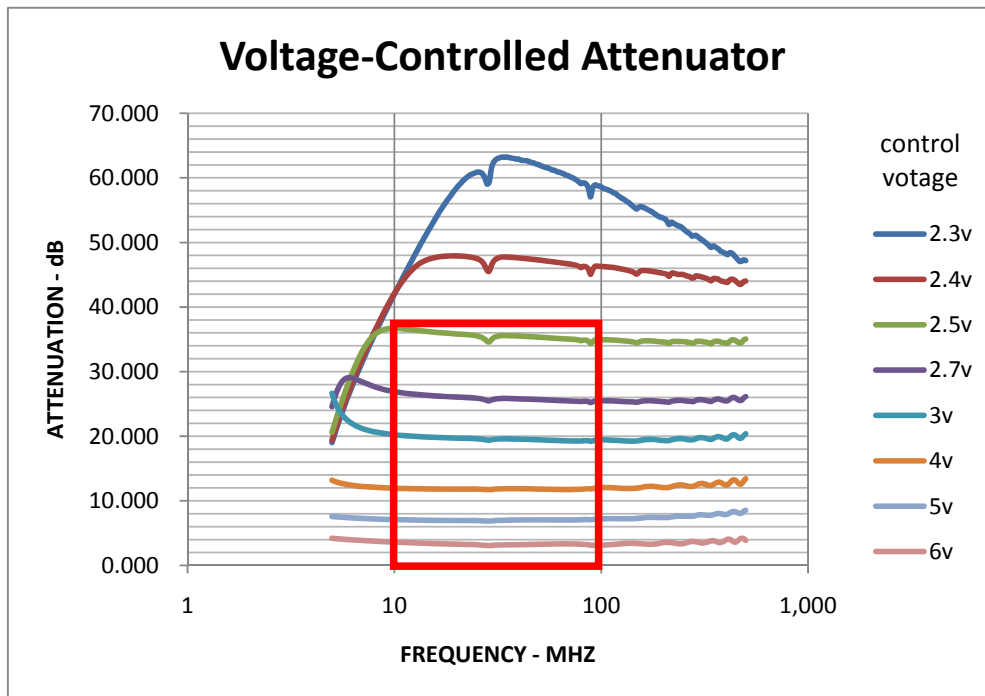

Figure 6: The property of the voltage-controlled attenuator.

The Open Loop Transfer function

Recall that the in-loop circuit consists of a voltage-controlled attenuator, a high power amplifier, an RF coupler and an in-loop RF detector and in-loop servo. The present design includes an excitation point between the RF detector and the servo. We use two points up and down streams of the excitation point to measure the open loop transfer function.

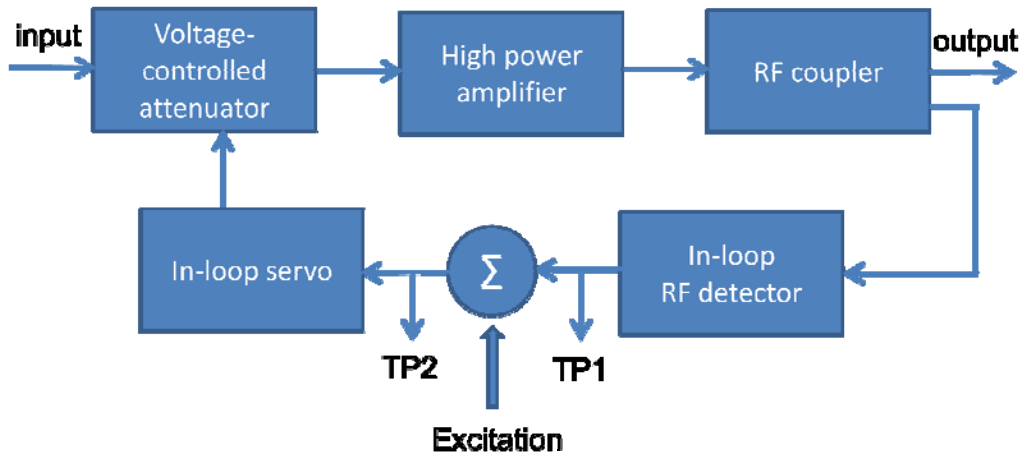

Figure 7: The conceptual schematic of in-loop circuit.

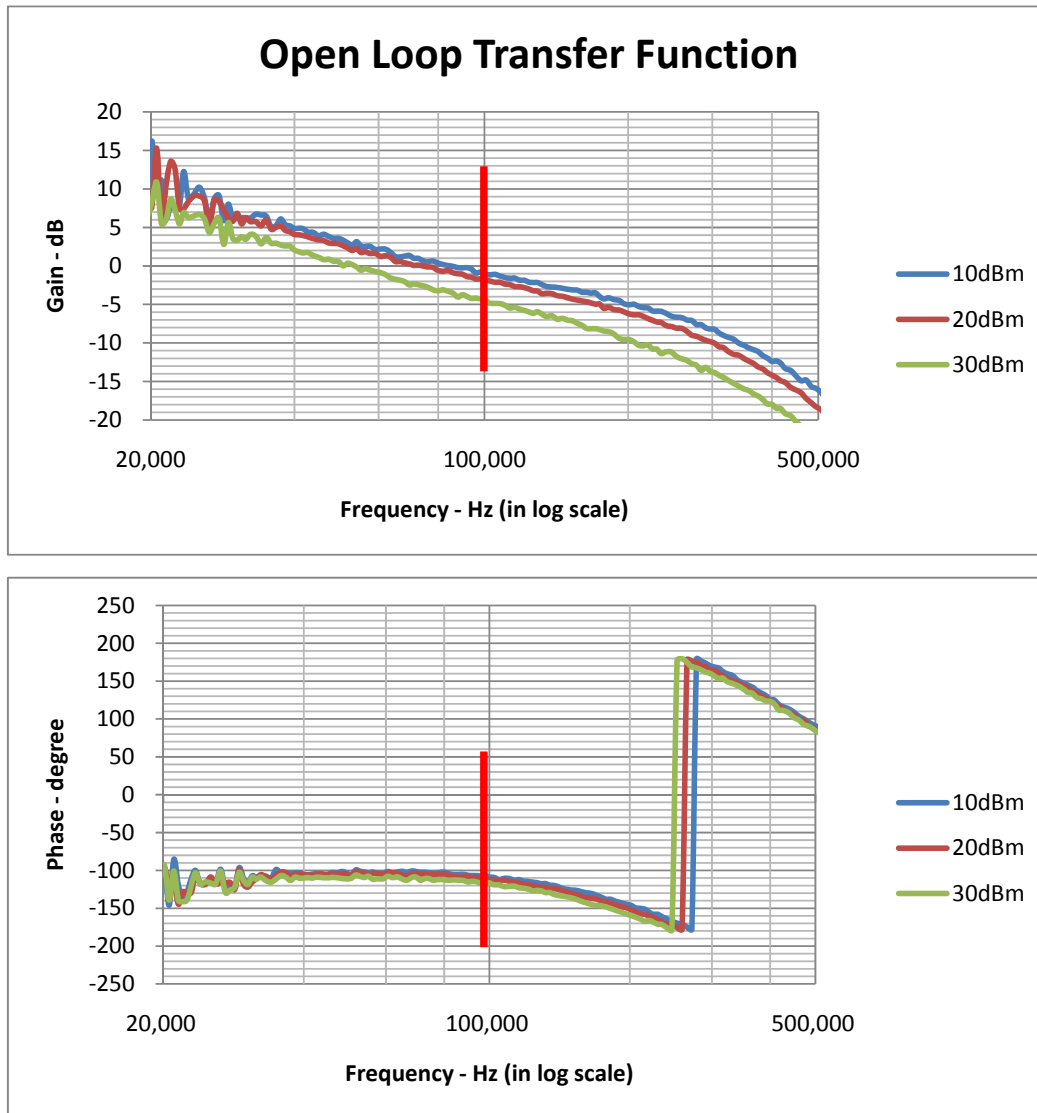

Figure 8: The Open Loop Transfer Function

Figure 8, above, shows the open loop transfer function at different output power levels with 21.5MHz RF input. We see that unity gain is at around 100kHz, which means the servo loop only stabilizes the signal below 100kHz. Conventionally, a servo loop aims at 50 phase margin and a negative phase margin will be considered as unstable. The phase plot shows that the phase margin ranges from 55 to 70, which means the servo loop is stable.

From the above graphs, we see that the phase doesn't depend on the power level in the circuit, while the gain shifted down when the output power level increased. Figure 9 below shows the detailed relationship between the gain at 100kHz and the RF output level. The figure verifies that the power level affects the unity gain while the input RF frequency does not.



Figure 9: Open loop gain at 100kHz.

Amplitude Noise

We measured the amplitude noise at the error output of the two RF detectors. Figure 10 shows the noise level for both the in-loop and out-of-loop circuit. For each circuit, we measure (1) the noise of the RF detector with a 50Ω terminator on the RF input, (2) the loop noise when the servo is turned on, and (3) the loop noise with the in-loop servo turned off, but including the power source, high power amplifier, and the RF detector. (The sensitivity for the in-loop circuit is 82 and the out-of-loop circuit is 80.)

Note that to measure the detector noise we would like to use 50Ω terminator on the RF input and disconnect the servo. This is possible to do because the servo and RF detector are physically located on different circuit boards. However, the out-of-loop automatic bias adjustment and RF detector are on the same board, and cannot be disconnected. Since the automatic bias adjustment has unity gain around 10Hz, it doesn't affect the noise above

10Hz. This most likely accounts for the difference between the in-loop and out-of-loop detector noise levels below 10Hz. Notice that the in-loop and out-of-loop RF detector noise levels are within 6 dB at frequencies greater than 10Hz. This is to be expected because the RF detector circuits are identical.

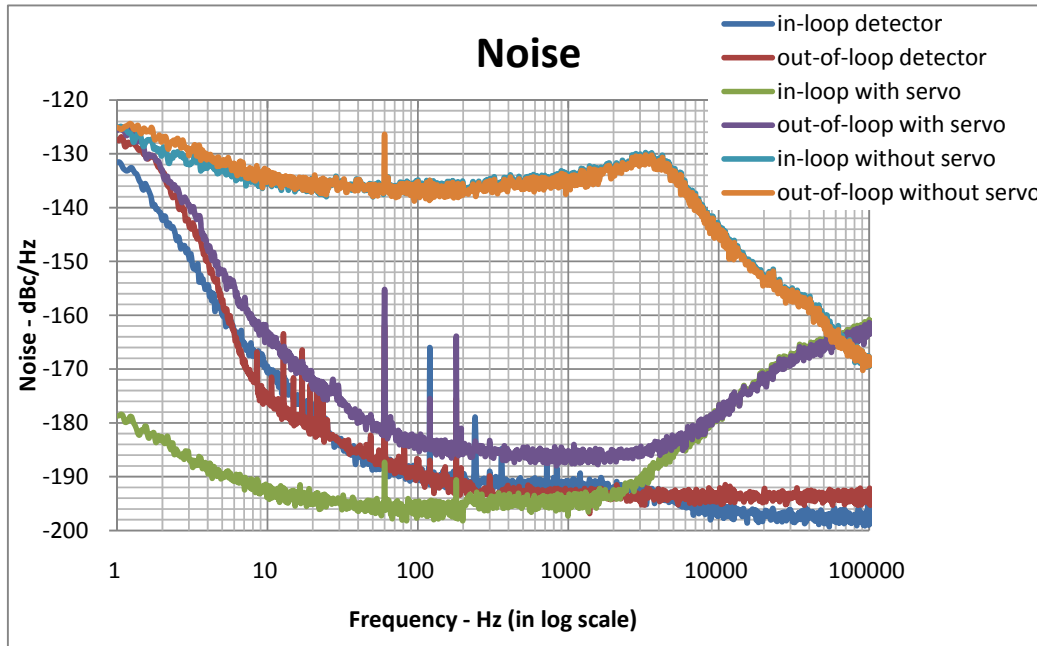

Figure10: Amplitude noise

Figure 10 shows that the noise level of the in-loop circuit (green curve) is much lower than the noise without servo, which indicates that the in-loop circuit reduced the noise level effectively. The difference between the without servo noise and with servo noise is what the in-loop circuit has improved.

At the unit gain (around 100KHz) we can see that the noise with servo meets the noise without servo. This is to be expected since at the unit gain, the servo output equals its input, so that it doesn't reduce the amplitude noise.

As I mentioned before, the out-of-loop circuit is used to check how well the in-loop stabilization circuit is. In theory, since all the noise from the source or other modules is removed by the in-loop circuit, if it didn't add additional noise to the RF signal, then the out-of-loop noise should be the sum of in-loop detector noise and the out-of-loop detector noise.

However, if we use the sensitivity mentioned above for both the detector noise and the noise with servo on, we can see that the out-of-loop noise with servo is larger than the sum. Consider the range in 50-4000Hz where the out-of-loop servo noise is flat, the lowest noise level one can reach is

$120 \text{ nv}/\sqrt{\text{Hz}}$. Using 80 as the sensitivity, we obtain a noise level of $1.5 \text{ nv}/\sqrt{\text{Hz}}$,

which is close to the factor of $\sqrt{2}$ of the noise of a 50Ω resistor. That is, the

out-of-loop noise can achieve the noise power of two $50\ \Omega$ resistors, which means both the in-loop and out-of-loop detector noise is close to the $50\ \Omega$ resistor's noise and the in-loop circuit does not add additional noise onto the signal. The reason that the out-of-loop noise appears larger in all frequency bands when the servo is on compared to the $50\ \Omega$ detector noise is due to a change in sensitivity. Since there is no RF carrier when we measured the detector noise, the detector diodes are not biased and the sensitivity will be somewhat lower.

Conclusions

The EOM/AOM driver works as designed. It can provide highly stabilized RF power from 10 dBm to 34.2 dBm. The amplitude noise satisfies the requirement level and is as low as one could expect. The RF detector effectively removes the noise from the source, stabilizes the circuit and does not add additional noise into the circuit.

Acknowledgments

Thanks to my mentor Dr. Daniel Sigg. He is always willing to explain the concepts and clarify the function of the circuit design. Also thanks to my co-mentor Paul Schwinberg and all the people in EE Lab for help assembling and understanding the circuitry.

I would also like to thank the NSF REU program, Caltech SURF program and the National Science Foundation for offering me this opportunity.

Appendix A

RF Detector

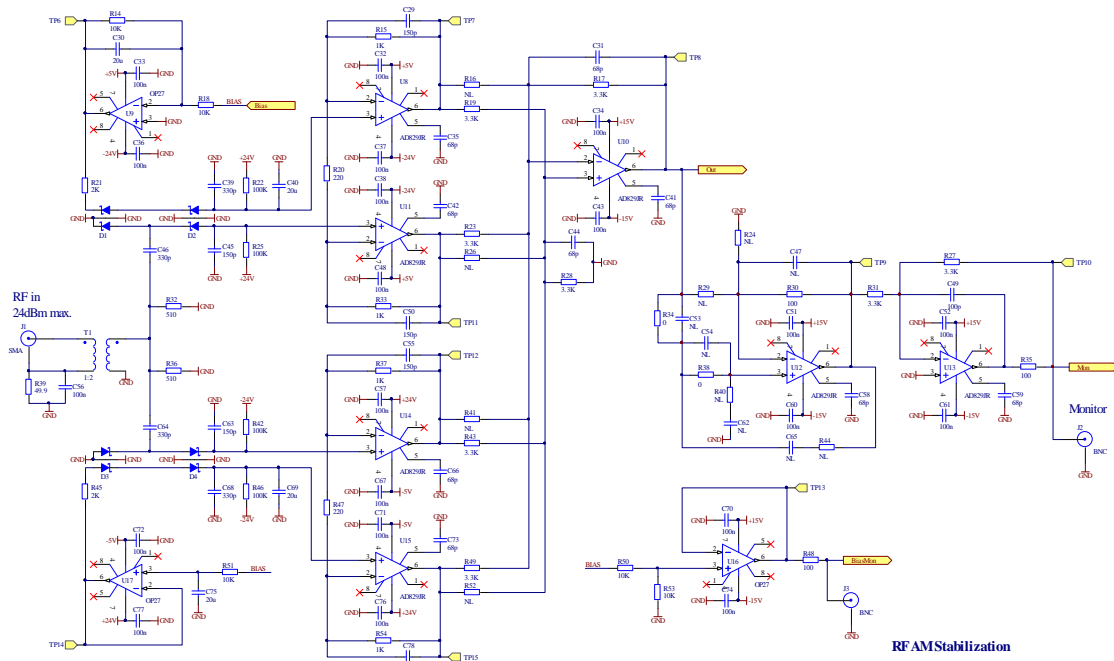

Out-of-loop Servo

