

REV.	DATE	DCN #	DRAWING TREE #
v1	23 MAR 2011	E1100216	
v2	09 MAY 2011	E1100335	

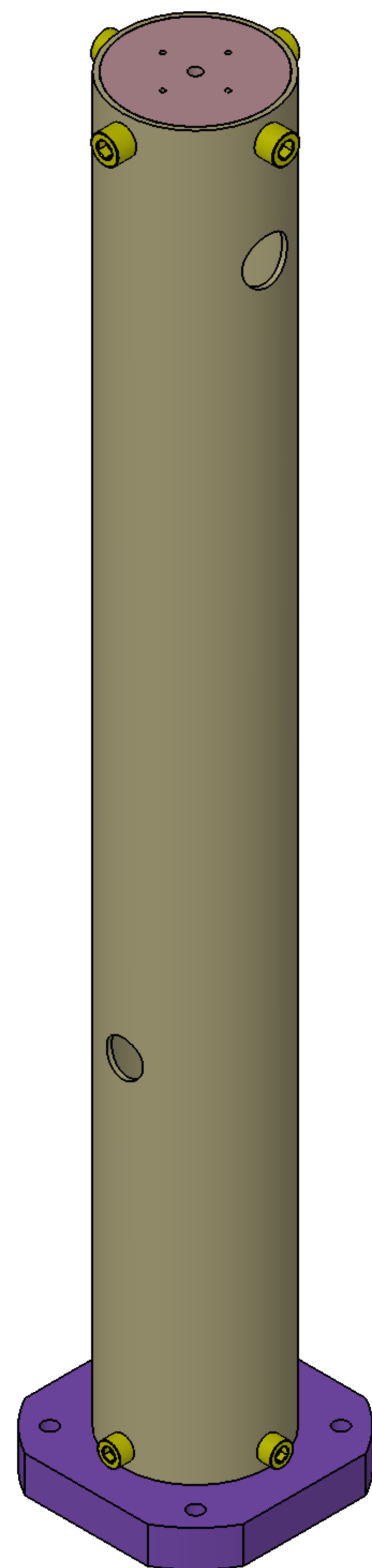

ISO VIEW

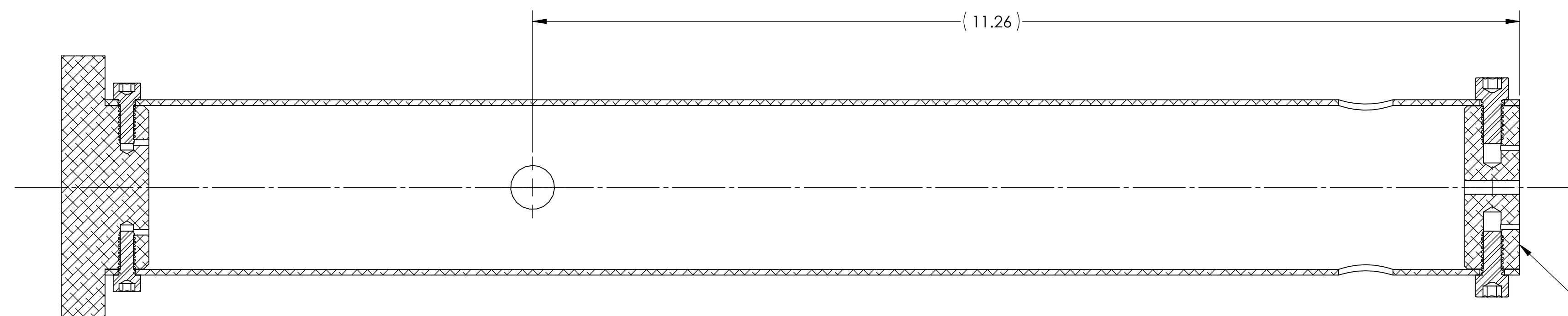

SECTION A-A
SCALE 1:1

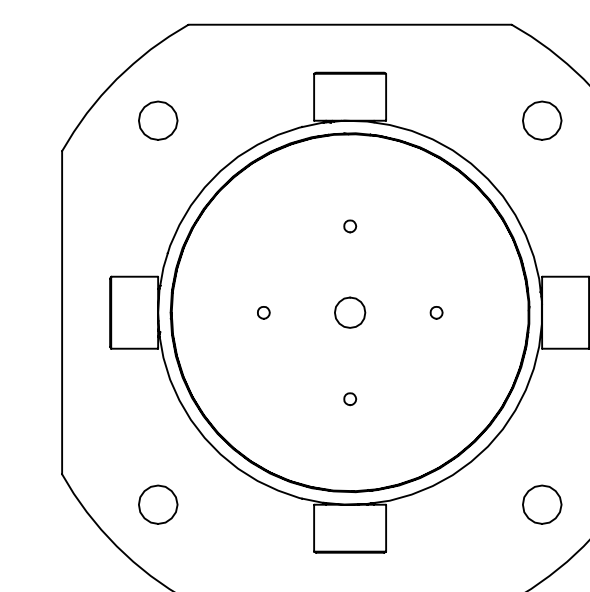
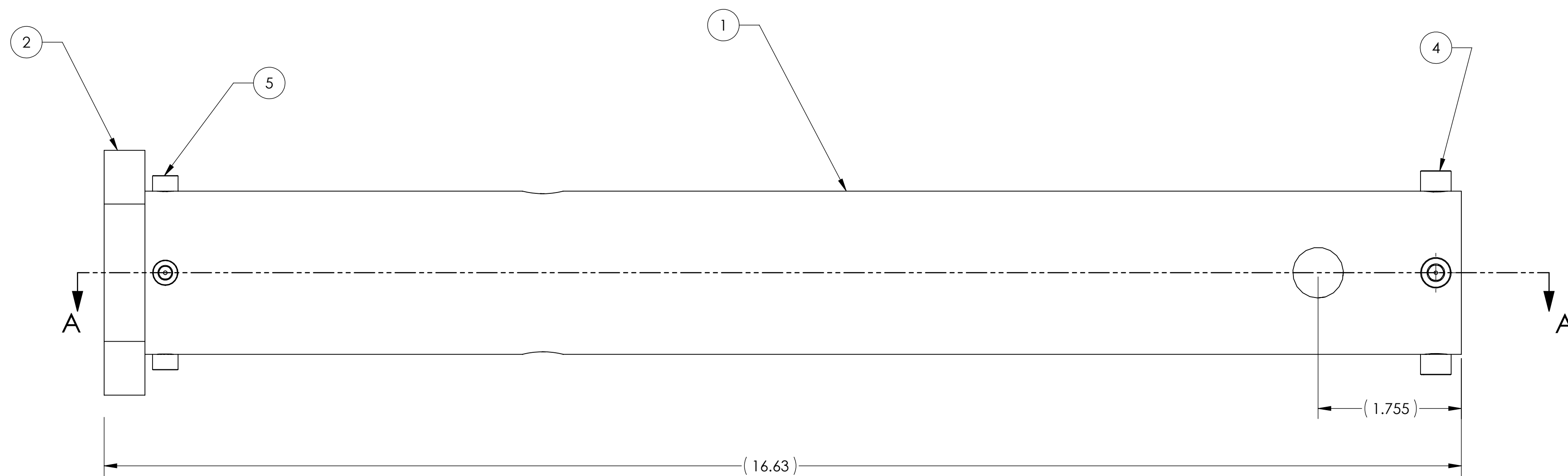

ITEM NO.	PART NUMBER	DESCRIPTION	MATERIAL	REQ	SPARE	TOTAL
5	92200A242	McMASTER, SOCKET HEAD SCREW, #10-24 X .50 LG, 300 SSSL	300 SSSL	4		4
4	92200A537	McMASTER_SOCKET HEAD CAP SCREW, .25-20 UNC-2A X .50 LG, 300 SSSL	300 SSSL	4		4
3	D1002581	SLC SUSPENSION ROD SUPPORT	6061-T6 Al	1		1
2	D1002610	SLC TUBE UP CONNECTOR PLATE	6061-T6 Al	1		1
1	D1002612	SLC UPPER TUBE	6061-T6 Al	1		1

NOTES AND TOLERANCES: (UNLESS OTHERWISE SPECIFIED)				LIGO CALIFORNIA INSTITUTE OF TECHNOLOGY MASSACHUSETTS INSTITUTE OF TECHNOLOGY		PART NAME	
DIMENSIONS ARE IN INCHES TOLERANCES: .XX ± .XXX ± ANGULAR ± °				1. INTERPRET DRAWING PER ASME Y14.5-1994. 2. REMOVE ALL SHARP EDGES, R.02 MIN. 3. DO NOT SCALE FROM DRAWING. 4. ALL MACHINING FLUIDS MUST BE FULLY SYNTHETIC, FULLY WATER SOLUBLE AND FREE OF SULFUR, SILICONE, AND CHLORINE.		SLC BAFFLE TUBE UP ASSEMBLY	
MATERIAL		FINISH		NEXT ASSY		PART NAME	
N/A		N/A μinch		D1001011		DESIGNER: TQ. NGUYEN DRAFTER: M. SMITH CHECKER: D. COYNE APPROVAL:	
DIMENSIONS ARE IN INCHES TOLERANCES: .XX ± .XXX ± ANGULAR ± °				SYSTEM: ADVANCED LIGO SUB-SYSTEM: AOS		SIZE: D DWG. NO.: D1002582 REV.: v2	
				SCALE: 1:1 PROJECTION:		SHEET 1 OF 1	

D1002582_AslUGO_AOS_SLC Baffle Tube Up Assy_PART PDM REV: X-022_DRAWING PDM REV: X-009