



LIGO Laboratory / LIGO Scientific Collaboration

E1000402-v6	<i>LIGO</i>	12 Apr. 2011
<hr/> Part Pre-preparation Instruction Helicoil_Dowel Pin Not including Actuator parts <hr/>		
M.Hillard		

Distribution of this document:
Advanced LIGO Project

This is an internal working note
of the LIGO Laboratory.

California Institute of Technology
LIGO Project – MS 18-34
1200 E. California Blvd.
Pasadena, CA 91125
Phone (626) 395-2129
Fax (626) 304-9834
E-mail: info@ligo.caltech.edu

Massachusetts Institute of Technology
LIGO Project – NW22-295
185 Albany St
Cambridge, MA 02139
Phone (617) 253-4824
Fax (617) 253-7014
E-mail: info@ligo.mit.edu

LIGO Hanford Observatory
P.O. Box 1970
Mail Stop S9-02
Richland WA 99352
Phone 509-372-8106
Fax 509-372-8137

LIGO Livingston Observatory
P.O. Box 940
Livingston, LA 70754
Phone 225-686-3100
Fax 225-686-7189

Assembly of Advanced LIGO BSC ISI

Clean room standards

For a clean assembly all LIGO standards should be followed, as presented in the latest version of the **LIGO Contamination Control Plan (E0900047)**. Clean room garb including UHV gloves should be worn when working with parts.

All tools that come in contact with assembly should be cleaned to class B standards.

Assembly will be done under a portable clean room. Any time a part of the assembly is not covered by the portable clean room or not being actively worked on it should be covered with appropriate clean covers. (C3 polyester or equivalent).

Torque Values for Bolts:

Standard torque values according to manufacturer standards for screw material should be used.

See E1000402 matrix to identify what and how many helicoils and or dowel pins to be inserted to parts this document is to supply insertion instruction for the parts. When applying dowel pins to the large plates (Detailed first) a hammering technique must be employed. This technique is illustrated in Appendix C and see a portion of T0900570 shown below a normal dowel application will insert the dowel into the Counterbore (lead in) hole and press the dowel to full depth of the pin hole (Hole Depth). Any deviation from this will be called out.

T0900570-v6

BSC ISI Design Standards

SEI Team

all dimensions given in INCHES, unless otherwise specified

Pins

use standard ground dowel pins, as shown on McMaster-Carr online catalog, page 3274

Material 18-8 SS

Size	Nominal Diameter	Tolerance	Nominal Length
1/8"	0.1251	+/--.0001	7/16"
1/4"	0.2501	+/--.0001	5/8"
3/8"	0.3751	+/--.0001	1"
1/2"	0.5001	+/--.0001	1 1/4"

Press-Fit Pin Holes, Class LN 1

Pin Size	Interference Limits	Diameter (with Bilateral Tolerance)	Hole Depth	Counterbore (Lead-In)		Near-Side Countersink	
				Diameter	Depth	Diameter	Angle
1/8"	0/.0005	.1250 +.0/--.0003	0.25	0.126 +.001/-0	0.060	0.15	90
1/4"	0/.00065	.2500 +.0/--.0004	0.38	0.251 +.001/-0	0.10	0.28	90
3/8"	0/.00065	.3750 +.0/--.0004	0.60	0.377 +.001/-0	0.13	0.42	90
1/2"	0/.0008	.5000 +.0/--.0006	0.75	0.502 +.001/-0	0.15	0.55	90

List of all parts that need to be prepared: List does not include Actuator Parts see individual actuator procedure for application details.

P/N	Helicoils:	Dowel pins:
D0900894	y	y
D0900895	y	y
D0901516	y	y
D0901517	y	y
D0901518	n	y
D0901519	y	n
D0901520	y	y
D0902273	y	y
D0902279	y	y

Smaller parts may use arbor press to install.

D0901499	y	y
D0901521	y	y
D0901522	y	y
D0901530	n	y
D0901531`	n	y
D0901532	n	y
D0901533	y	y
D0901535	y	y
D0901536	y	y
D0901537	y	n
D0902274	y	y
D0902276	y	n
D0902277	y	y
D0902278	y	y
D0902281	y	y
D0901554	y	n
D1100564	n	y

Tools required:

QTY	Part Number	Description
1	48" 3 pt sling	
3	MM 2949T35	hoist rings with ½" threaded bolt (max load per ring 1250 lbs)
or		
3	MM 33045T53	shoulder eyebolt (max load per bolt 2400 lbs)
6	2-4-6	tooling blocks
1	height gage	
1	3/8"	helicoil installation tool
1	1/4"	helicoil installation tool
1	5/8"	helicoil installation tool

- 1 3/8" tangs breaker
- 1 1/4" tangs breaker
- 1 5/8" tangs breaker
- 1 10 - 150 ft lb torque wrench

Stage 0 plates on granite table

Drawings: D0900894, D0900895 to determine where and what size dowel pins or Helicoils to install.

Parts required

QTY	Part Number	Description	Weight
1	D0900894	bottom part	636 lbs
1	D0900895	top part	573 lbs

Note: To move these large parts, use the three 1/2-13 eyebolts holes equally spaced on them, circled in red on Figure 1.1. The three green circles of this figure shows where the 1/2-13 eyebolts should be attached on the other side (if the plate needs to be flipped). They are at the same positions on both D0900894 and D0900895. Torque them to manufacturer value.

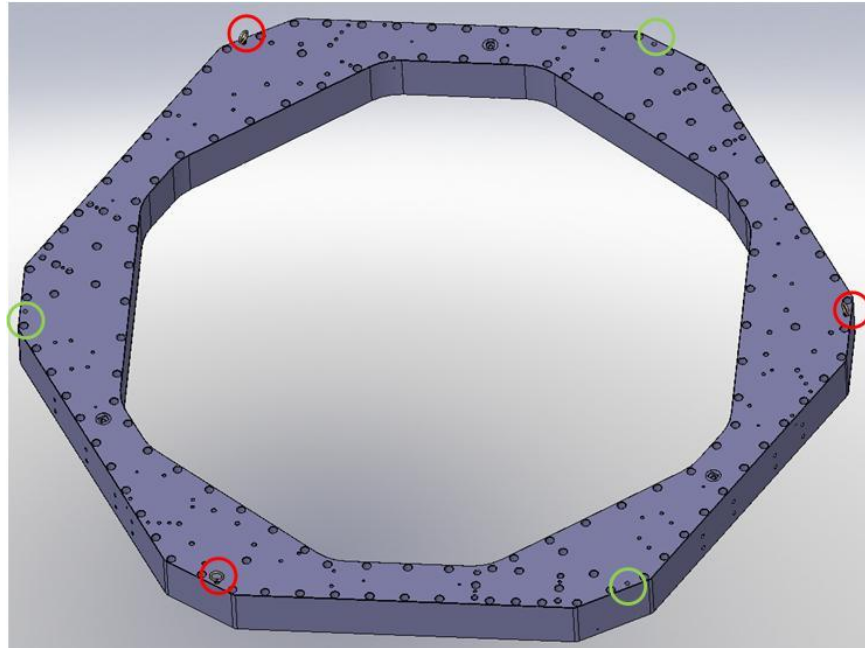
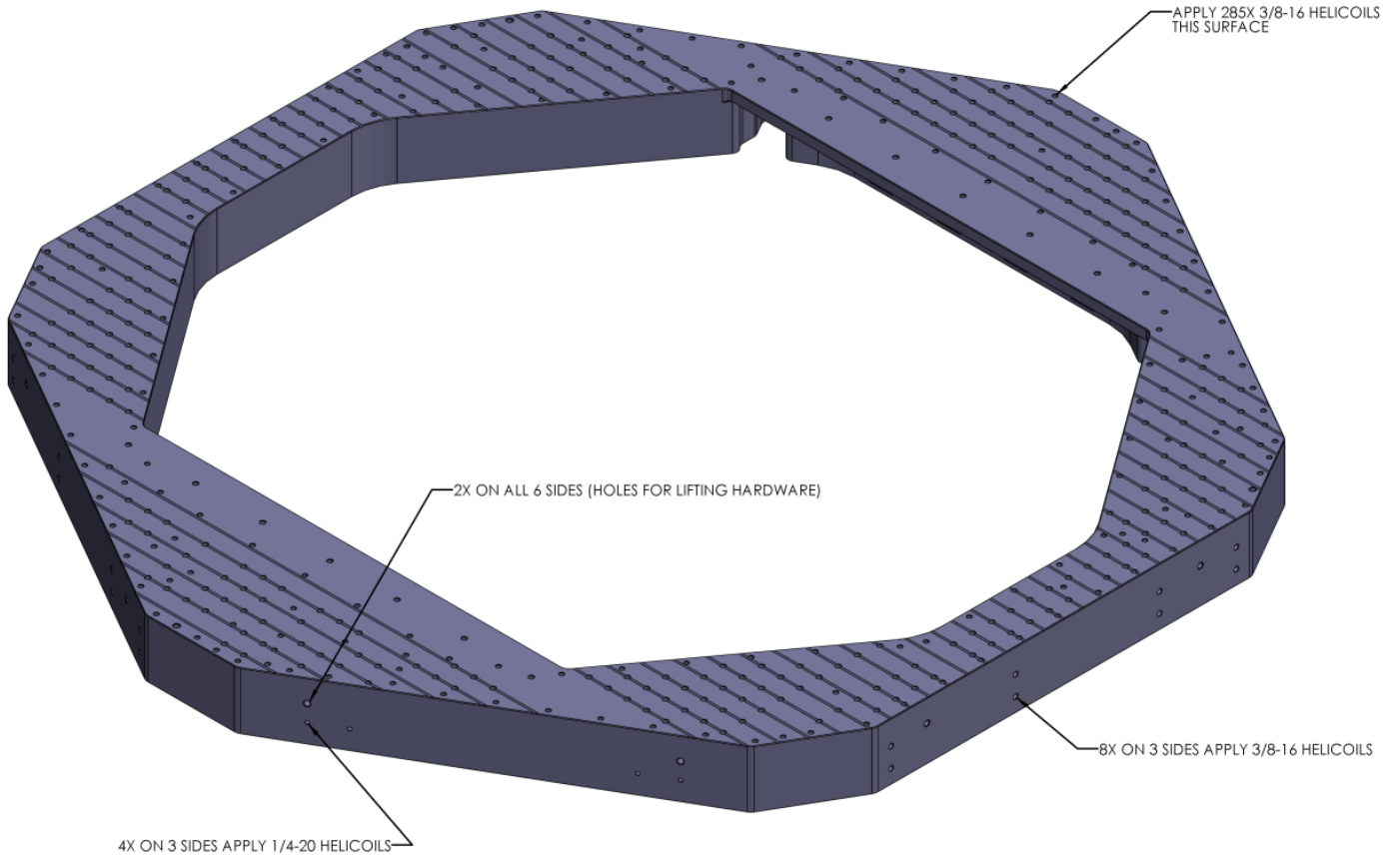

Figure 1 Location of 1/2-13 holes for sling attachment on D0900894 vent grooves not shown
1. Place bottom part (D0900894) on level tooling blocks on granite table- ribs side down.



Preparation of D0900894: see drawing D0900894

Hardware: See E1000402 matrix for required hardware

1. Apply helicoils in locations shown Figure 2

2. Place D0900894 with helicoiled surface (flat surface with grooves) facing down and pocketed surface facing up.
3. Insert dowel pins see Appendix C for insertion depth, apply 1/2 x 1.25 dowel pin Qty. 3 in locations shown on Figure 3.

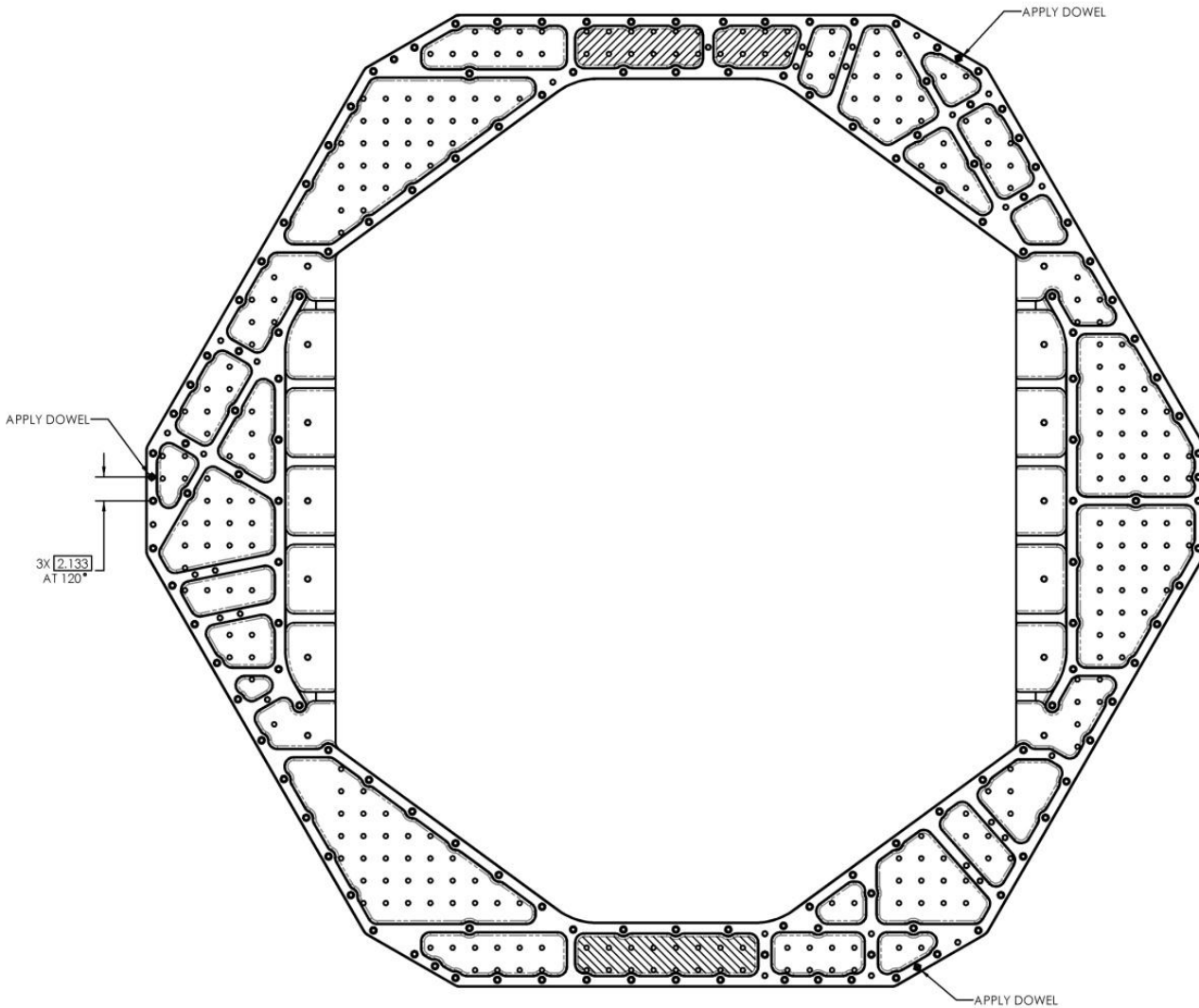

Figure 3

Preparation of D0900895: see drawing D0900895 (1/3 of the part is shown)

Hardware: See E1000402 matrix for required hardware

1. Apply helicoils in locations shown Figure 4 and Figure 5 see Appendix C for Qty. and p/n

Figure 5

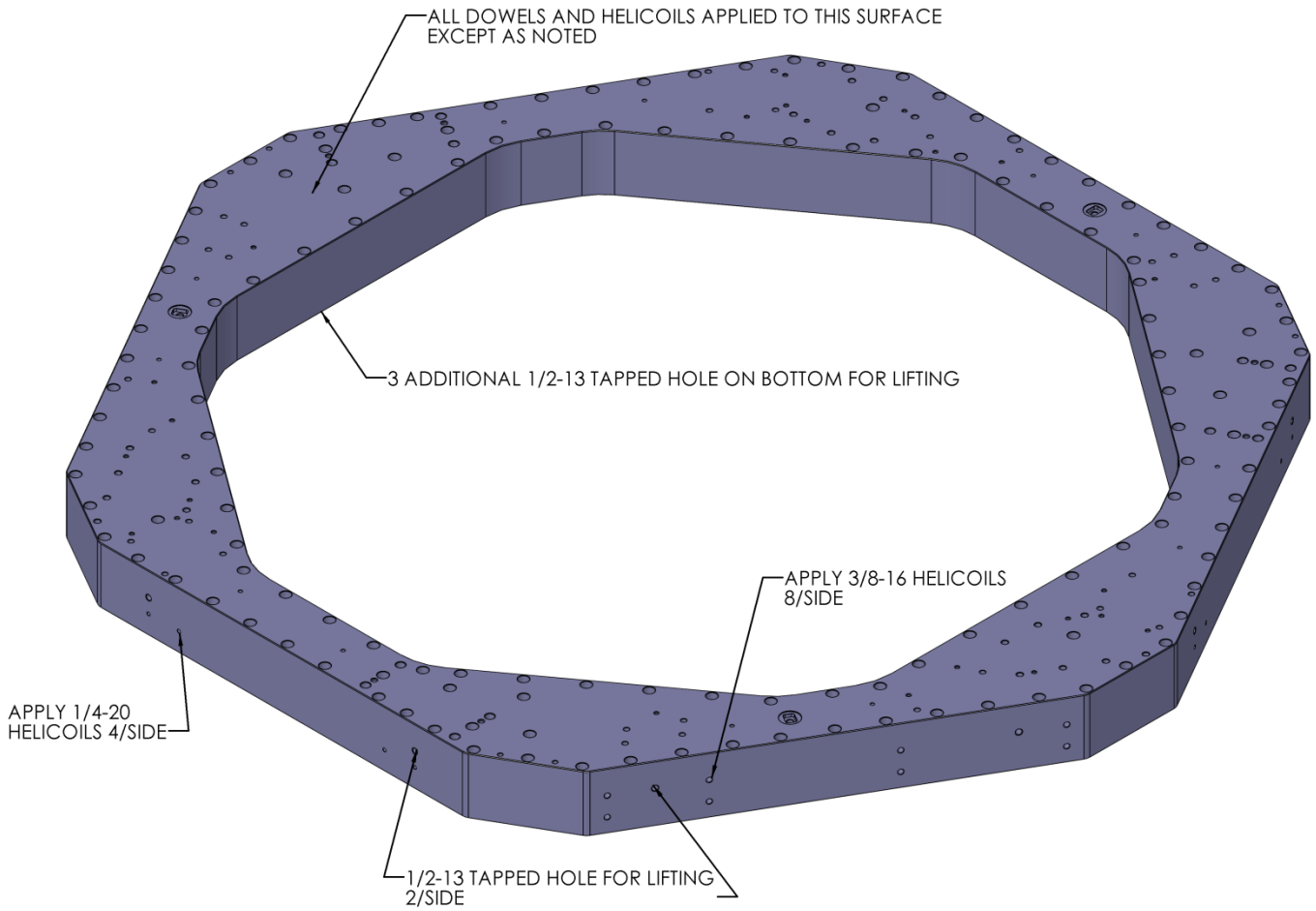

(1/3 of the part is shown)

Figure 4

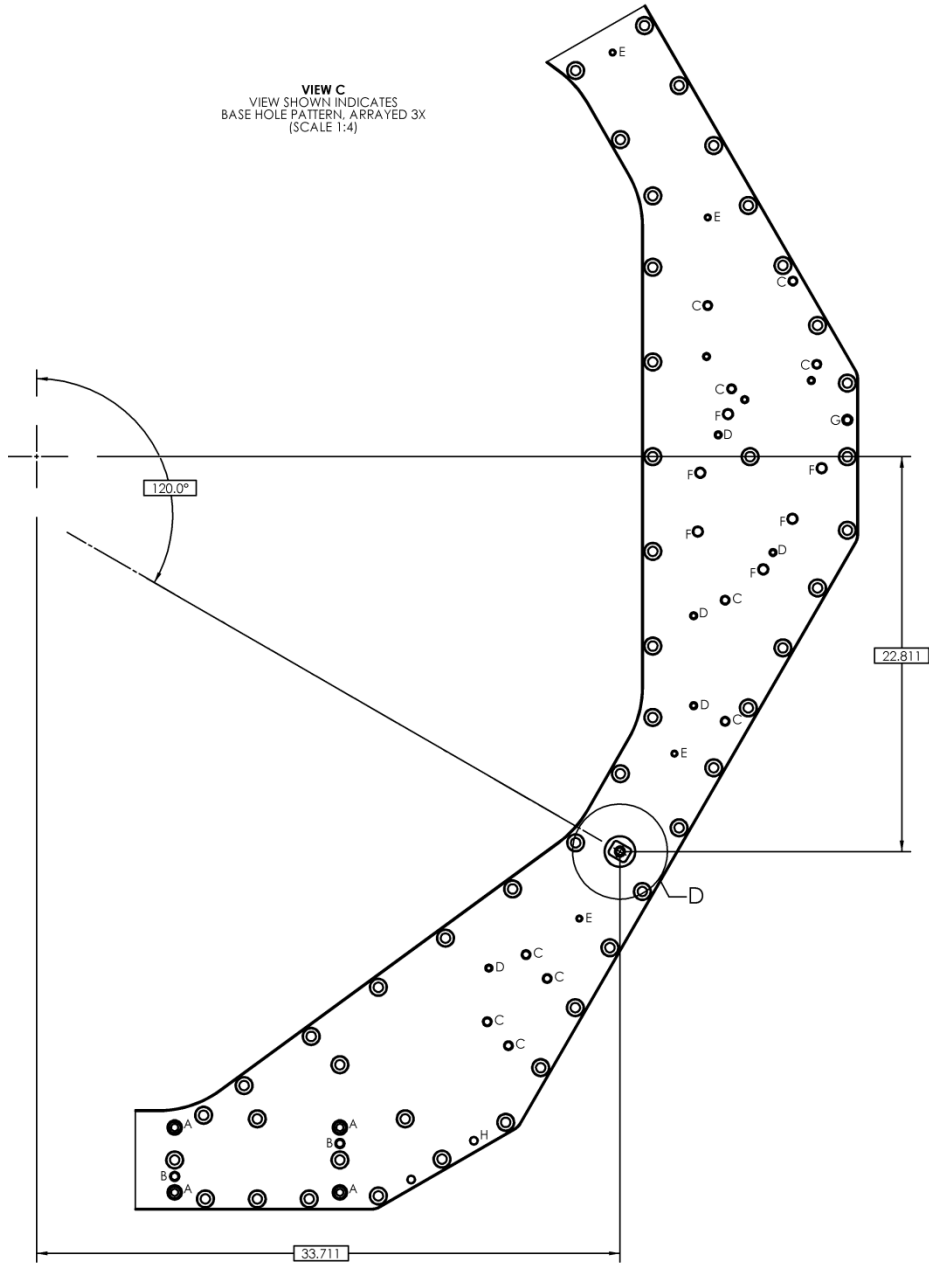

Hole designation ID pattern is arrayed 3X disregard holes with letters F,G and H

A=5/8-11 helicoils

C=3/8-16 helicoils

E=1/4-20 helicoils

2. Insert 1/2" dowel pins Qty. 6 as shown on Figure 5 and Appendix C for p/n and illustration for 1/2 x 1.25 dowel pin.

B=1/2" dowel pin holes

D=3/8" dowel pin holes 3. Insert 3/8" dowel pins Qty. 15 as shown on Figure 5 and Appendix C for p/n and illustration for 3/8 x 1 dowel pin.

Stage 2 plates on granite table (1/3 of the part shown)

Parts required

QTY	Part Number	Description	Weight
1	D0901516	solid optical table (facing down)	932 lbs
1	D0901517	cut-out optical table (facing up)	685 lbs

Preparation of D0901516: see drawing D0901516 (1/3 of the part shown)

- Place D0901516 on granite table using level blocks, ribbed side down Figure 6.1
Install Helicoils all 3217 on the Top (not shown below) and install helicoils labeled
B=3/8-16 helicoils
C =1/4-20 helicoils.
E=5/8-11 tapped holes for lifting
- Rotate plate install Dowel pins see Figure 6.2 and Appendix C for p/n and illustration
for 1/2 x 1.25 dowel pin, Figure 6.2. install Helicoils on the ribbed side labeled
#3=3/8-16 helicoils . Hole designation ID pattern is arrayed 3X

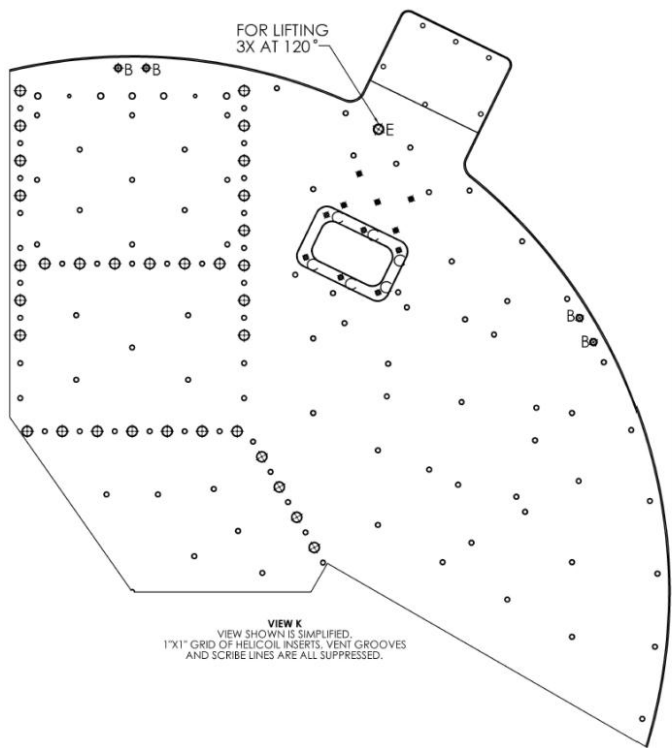

Fig 6.1

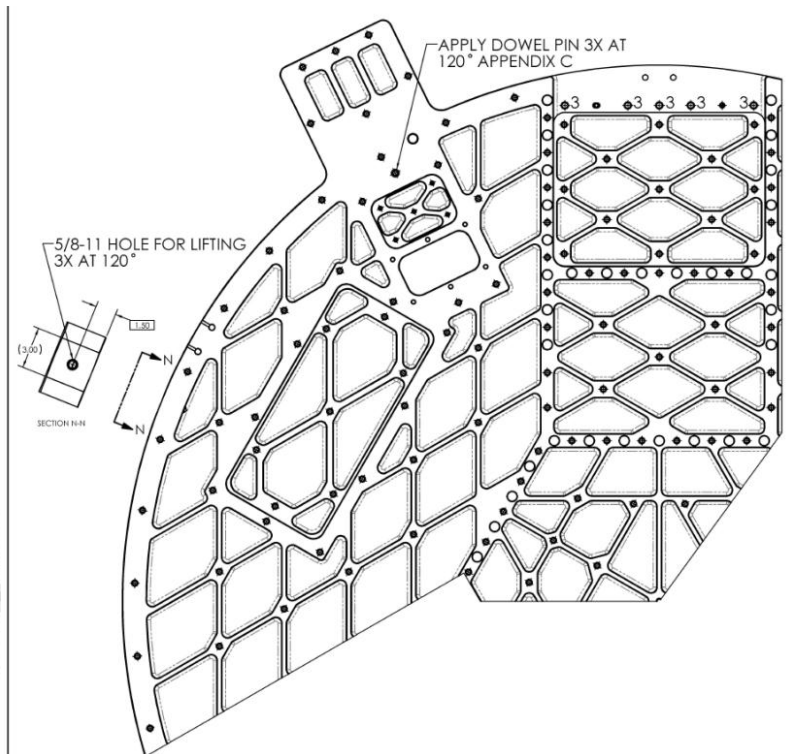

Fig 6.2

Preparation of D0901517: see drawing D0901517 (1/3 of the part is shown)

1. Place D0901517 on granite table rib side down install dowel pins in locations labeled B and E = 3/8" dowel pin holes
 see Appendix C for p/n and illustration for 3/8 x 1" dowel pin Qty. 30 as shown on Figure 6.1. Hole labeled D is 5/8"-11 for lifting Fig 7.1.

1. Rotate plate Place D0901517 on granite table using level blocks, ribbed side up
 Install Helicoils locations labeled
 #1=3/8"-16 helicoils
 and Dowel pins 3 locations labeled #2 See arrow Fig 7.2.

Fig 7.1

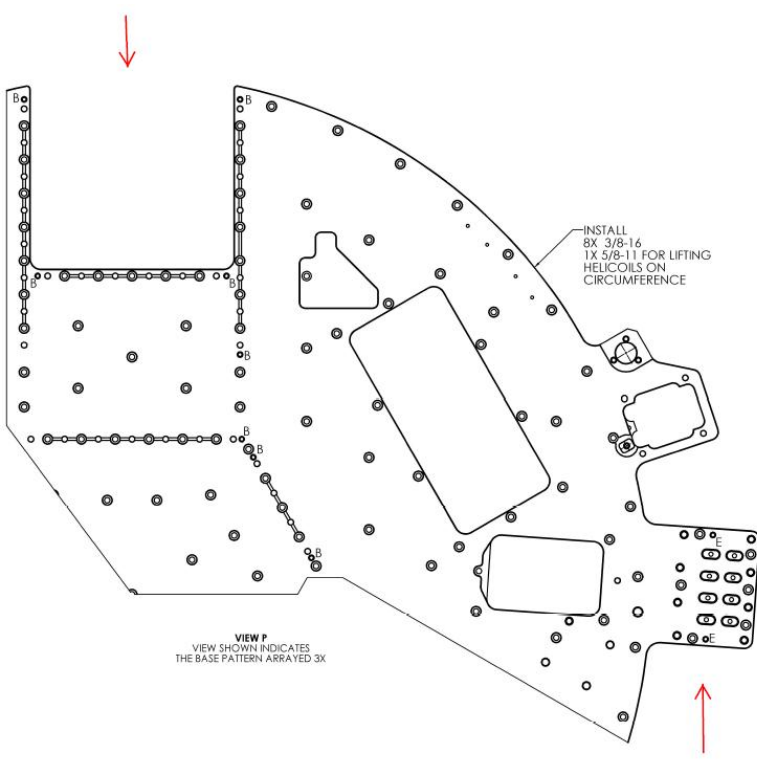
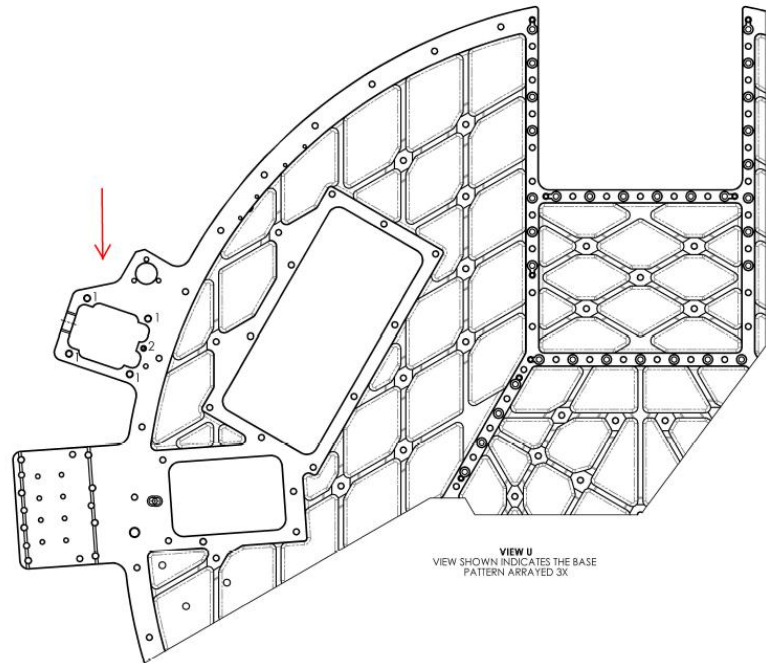

Fig 7.2



Preparation of D0901518: see drawing D0901518

1. Rotate plate install dowel pins in locations noted, Insert 1/2 x 1.25" dowel pins see Appendix C for p/n and illustration for 1/2 x 1.25 dowel pin see Figure 8

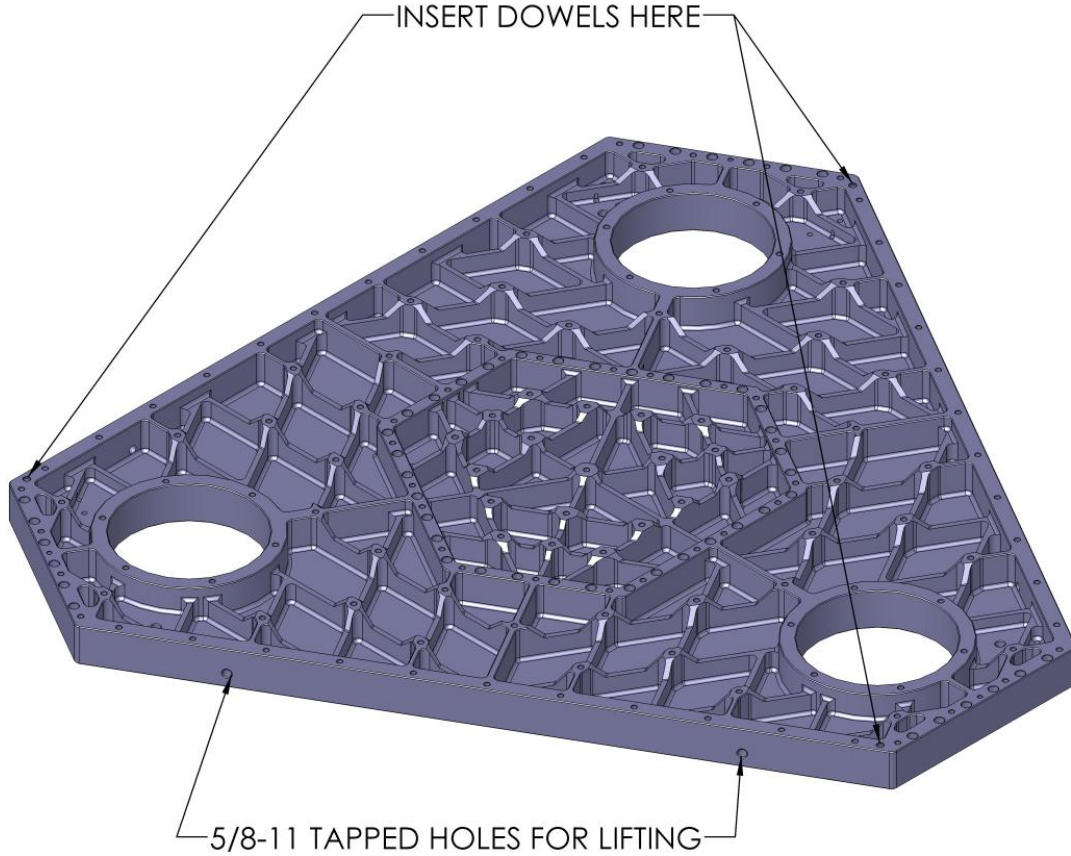

Figure 8

Preparation of D0901519: see drawing D0901519

1. Install helicoils in locations shown Figure 9 There are no dowels installed in this part.
A and C=3/8-16 helicoils and holes
E=5/8-11 helicoils used for lifting.

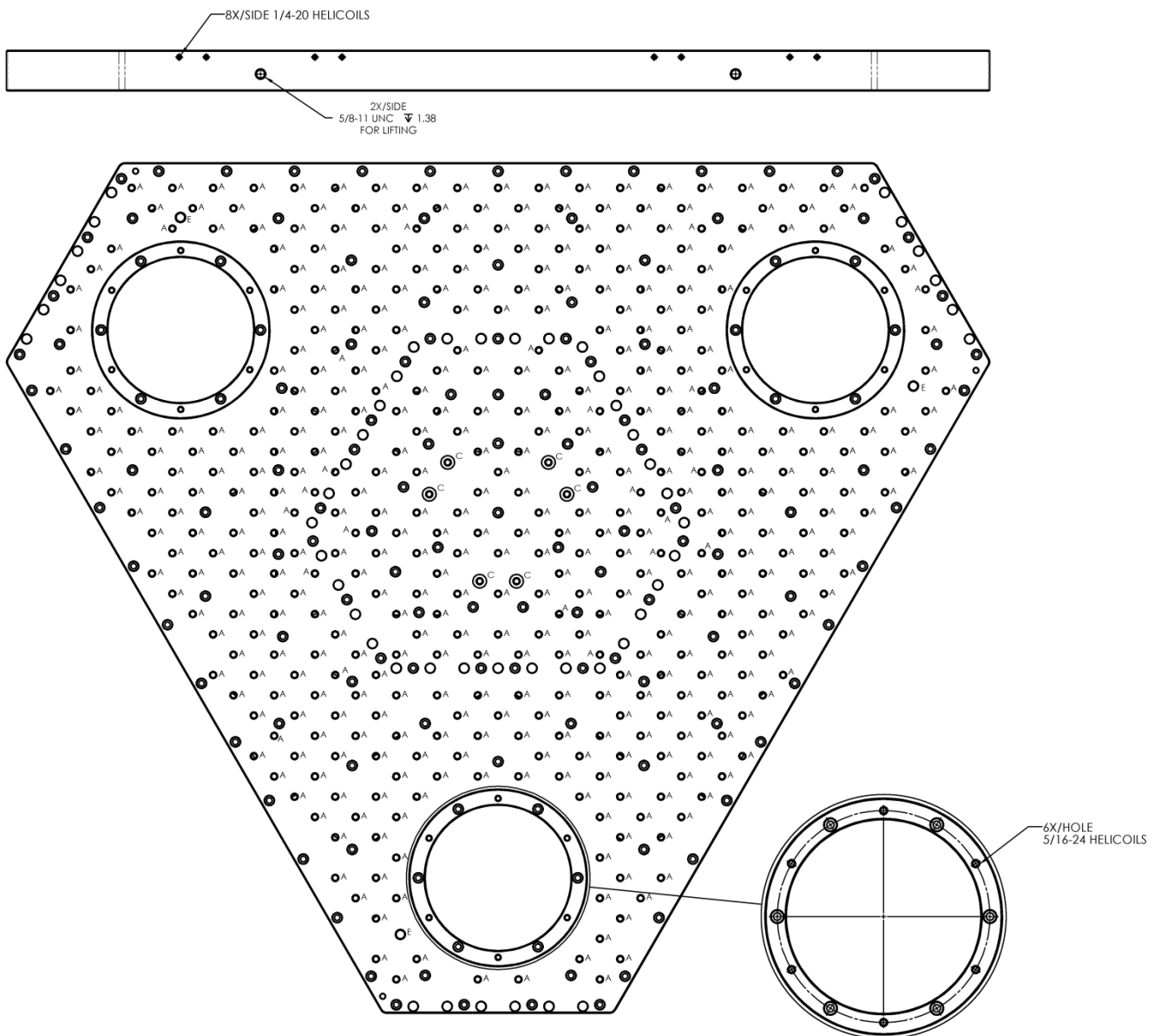

Figure 9

Preparation of D0901520: see drawing D0901520

1. Install helicoils and dowels in locations shown Figure 10 and detail Figure 11 Dowels to be inserted on **non-grooved side**.
2. "B"= 3/8-16 helicoils
"C"= 1/4 dowel pin holes
"D"= 3/8 dowel pin holes
"E"= 1/4-20 helicoils

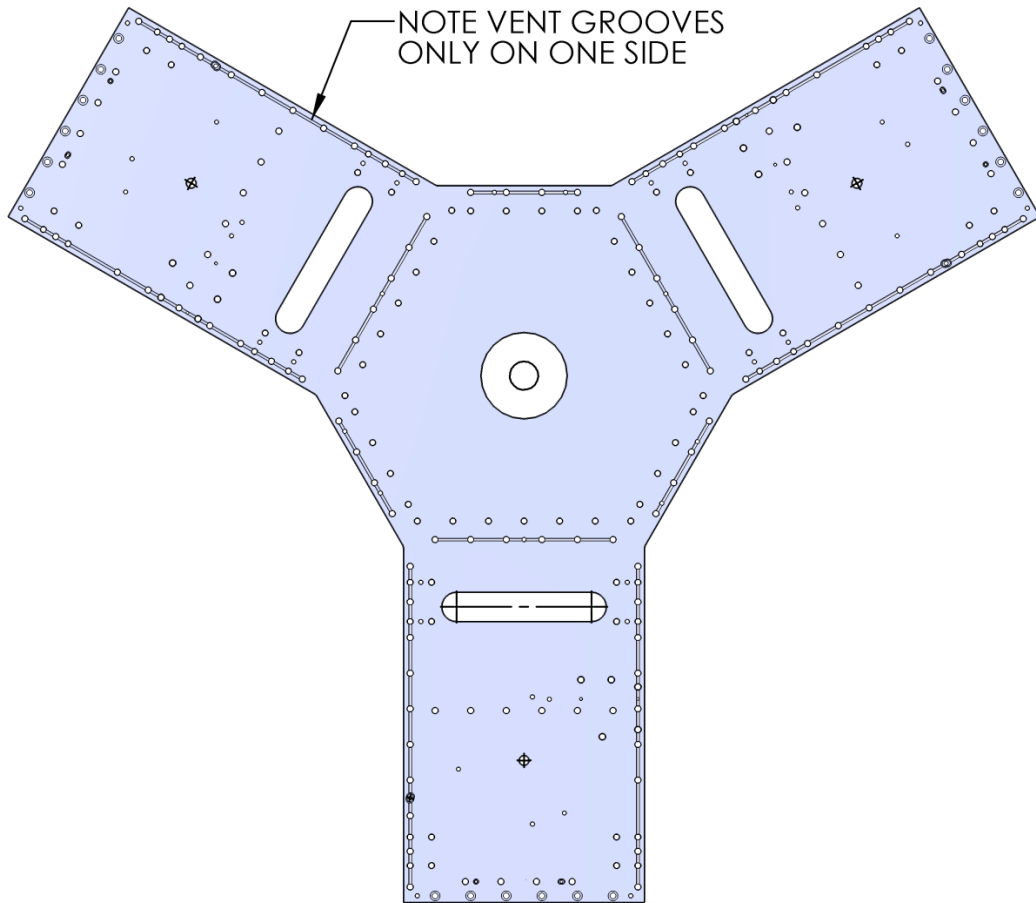

Figure 10

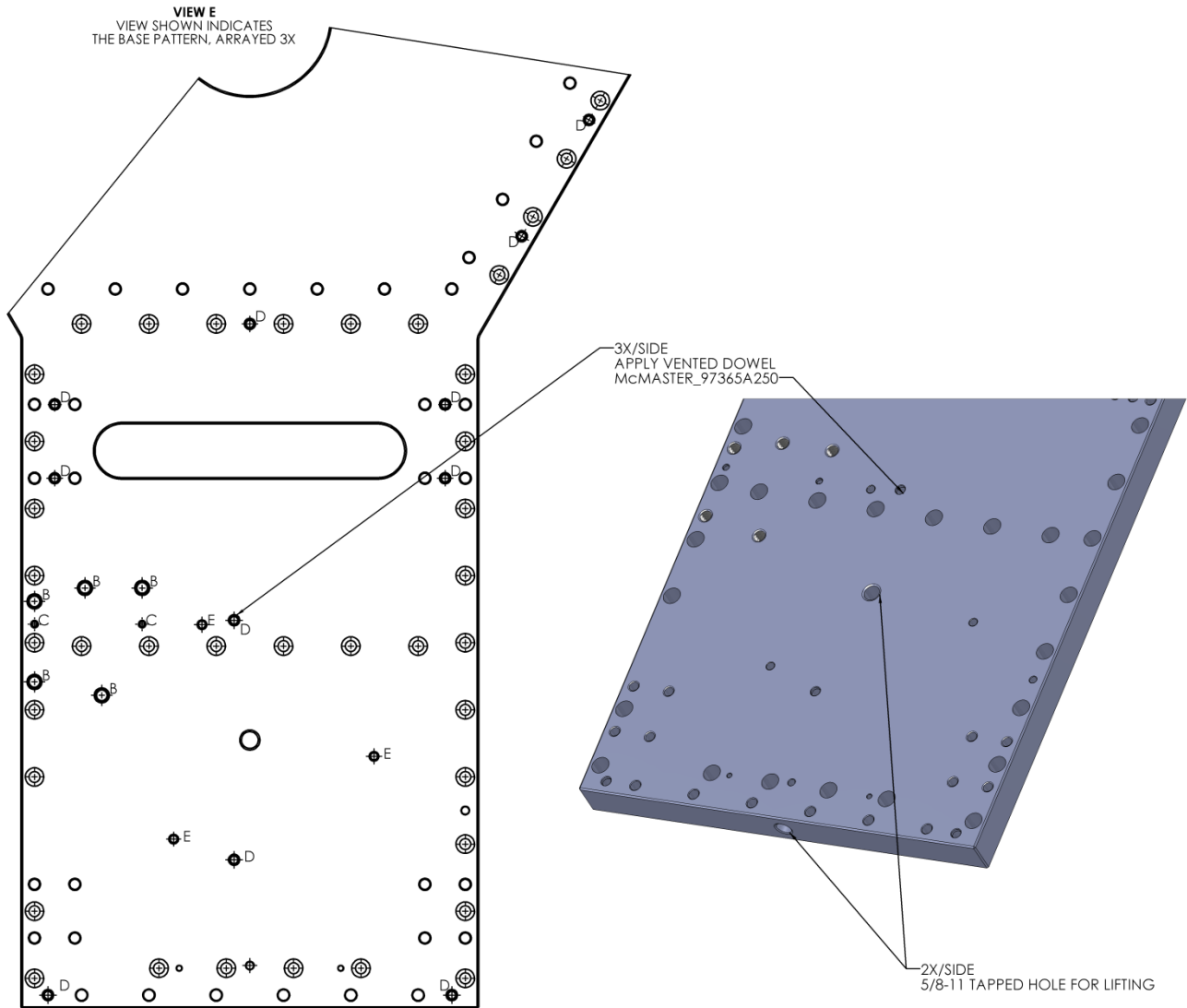

Figure 11
Detail of D0901520

Be absolutely sure to press in the vented dowel pins as shown in Figure 11 this is required for proper venting of the GS-13 vertical assembly

Preparation of D0902273: see drawing D0902273

1. Install helicoils and dowels in locations shown Figure 12 see appendix C for p/n and installation instructions

Figure 12

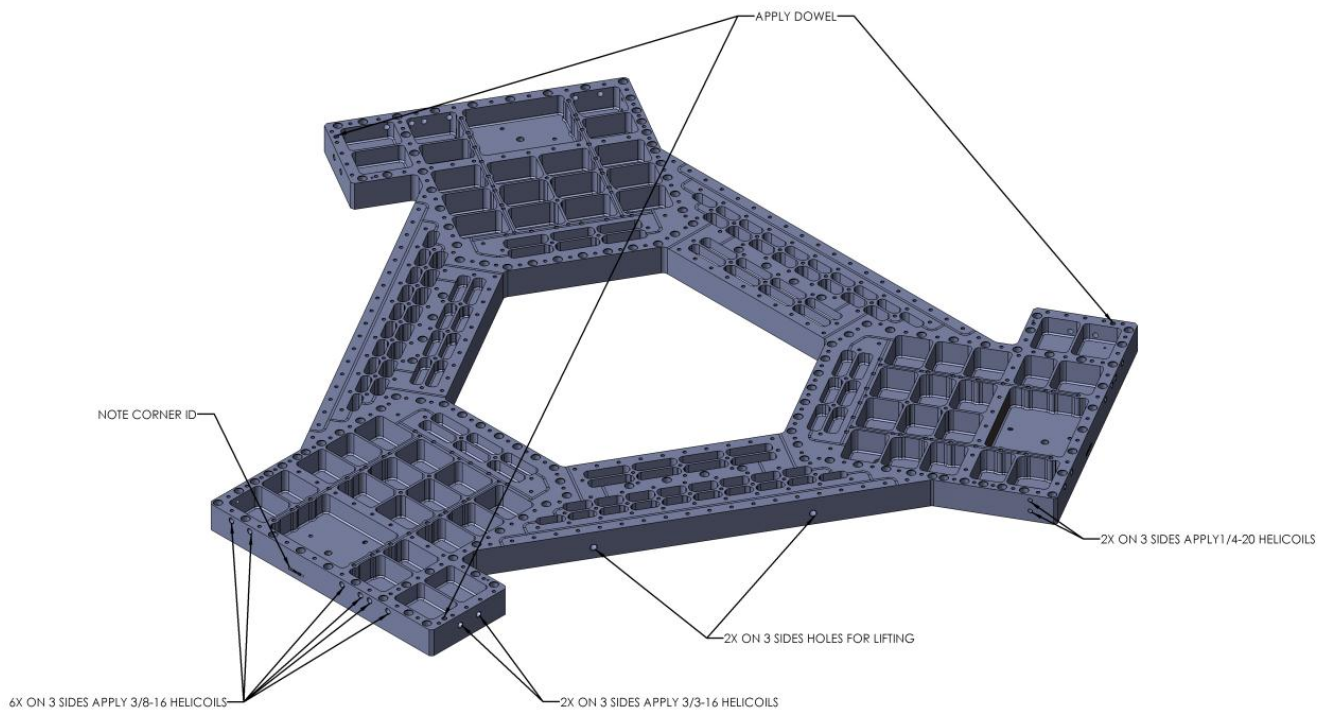

Preparation of D0902279: see drawing D0902279

1. Install helicoils and dowels in locations shown Figure 13.1 and 13.2 see appendix C for p/n and installation instructions

Hole designation ID pattern is arrayed 3X

A and #1= 3/8 dowel pin holes (note location of 3/8 x 5/8" dowels)

#3=3/8-16 helicoils

#4=1/4-20 helicoils. Helicoils are inserted from the same side as shown.

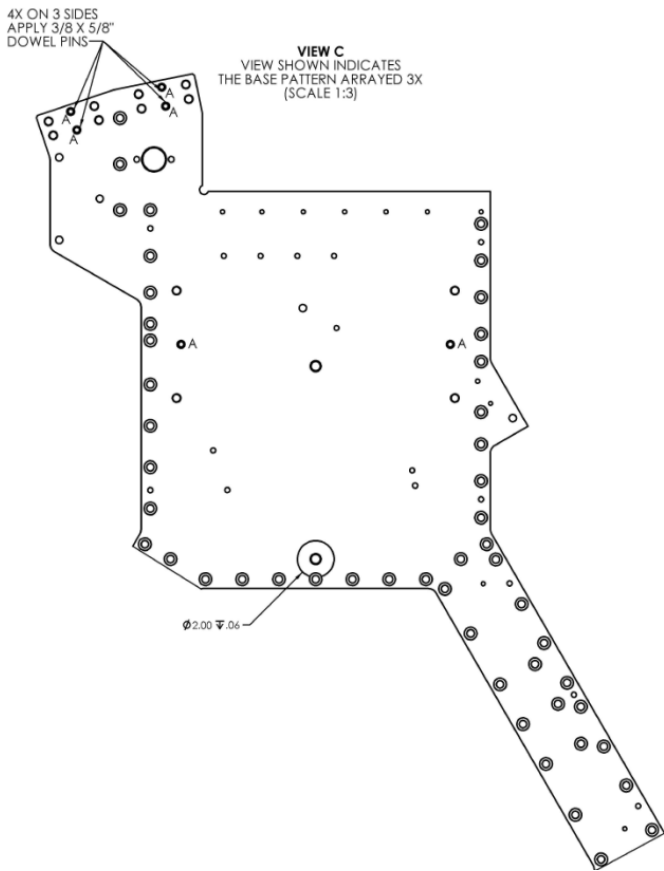

Fig 13.1

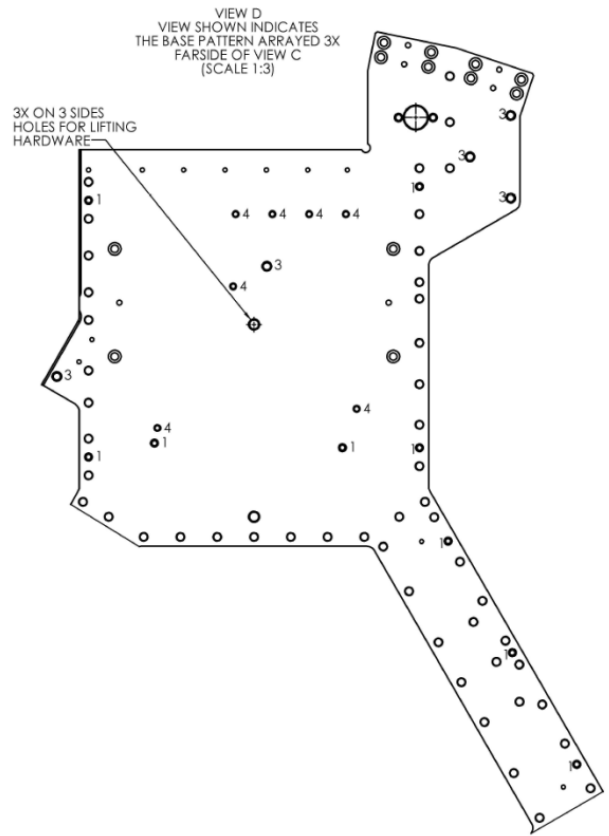

Fig 13.2

9. Insert 3/8 x 5/8" dowel pins Qty. 12 (only 4 shown on Figure 14 .535" deep (dowel will not bottom out) and must remain .09 above surface see appendix C for P/

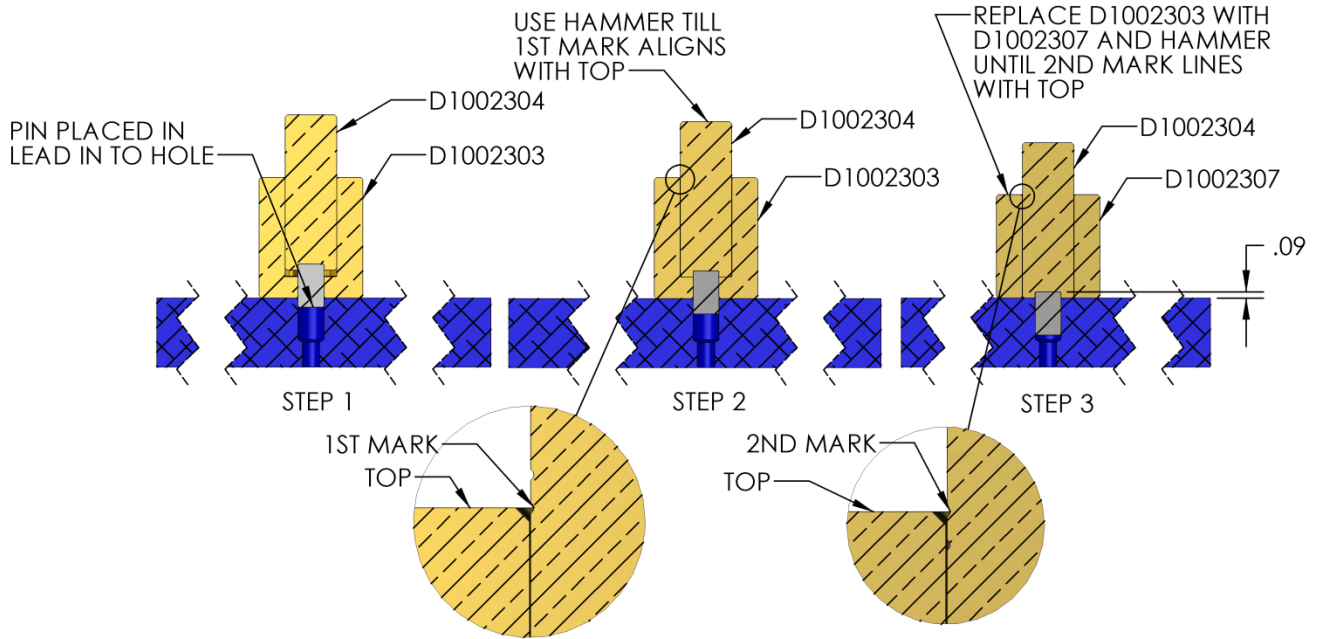

Fig 14

10. Insert 3/8 x 1" dowel pins Qty. 6 marked "A" as shown on Fig 12.1 and Qty 27 marked #1 Fig 12.1. Press dowel per appendix C for P/N and illustration for 3/8 x 1 dowel pin.

11. Install 3/8-16 helicoils as shown in figure 15.

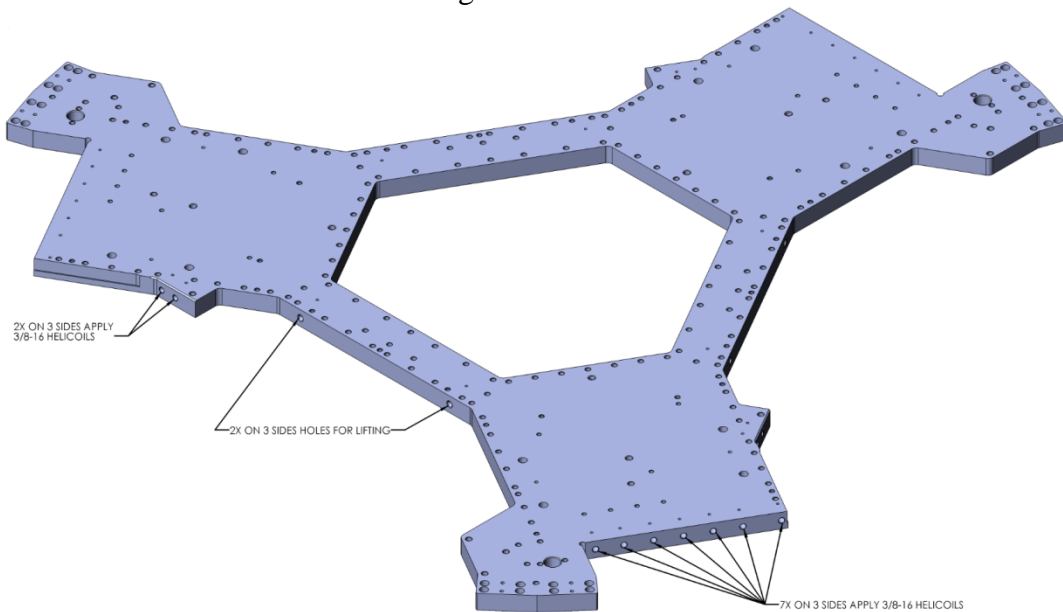

Fig 15

The large plate are now complete:

The remainder of the parts may be completed using an arbor press for dowel insertion:

Preparation of D0901499:

1. Apply helicoils and dowel pins as shown Figure 16

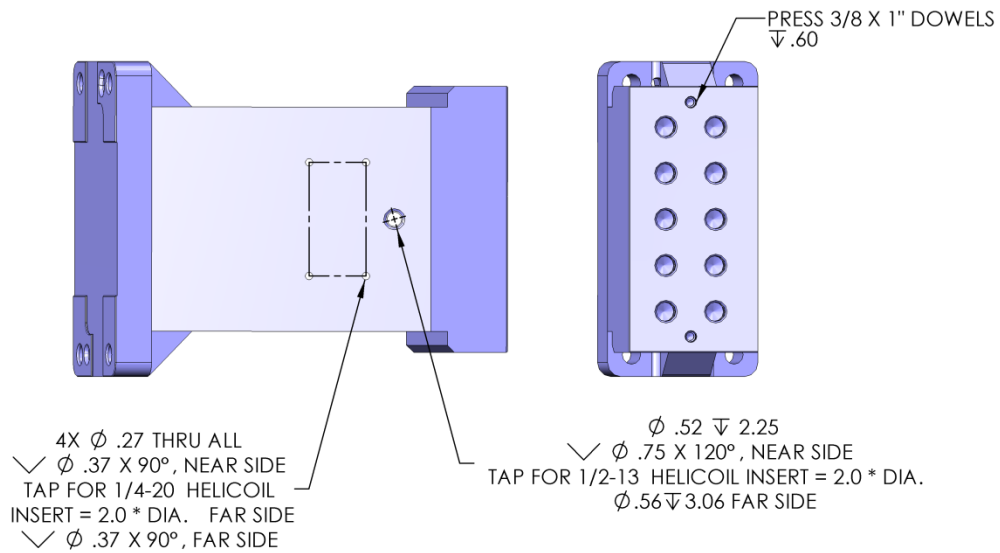

Figure 16

Preparation of D0901521:

1. Apply helicoils and dowel pins as shown Figure 17

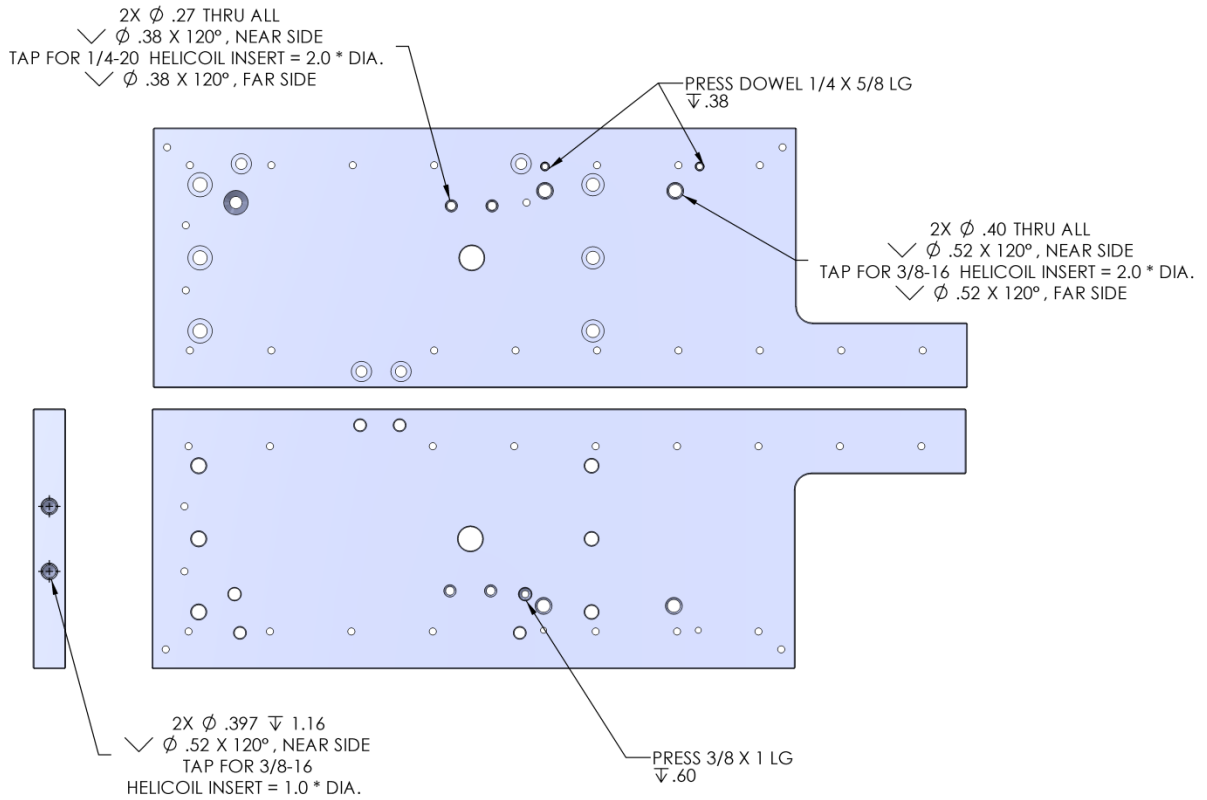

Figure 17

Preparation of D0901522:

1. Apply helicoils and dowel pins as shown Figure 18.

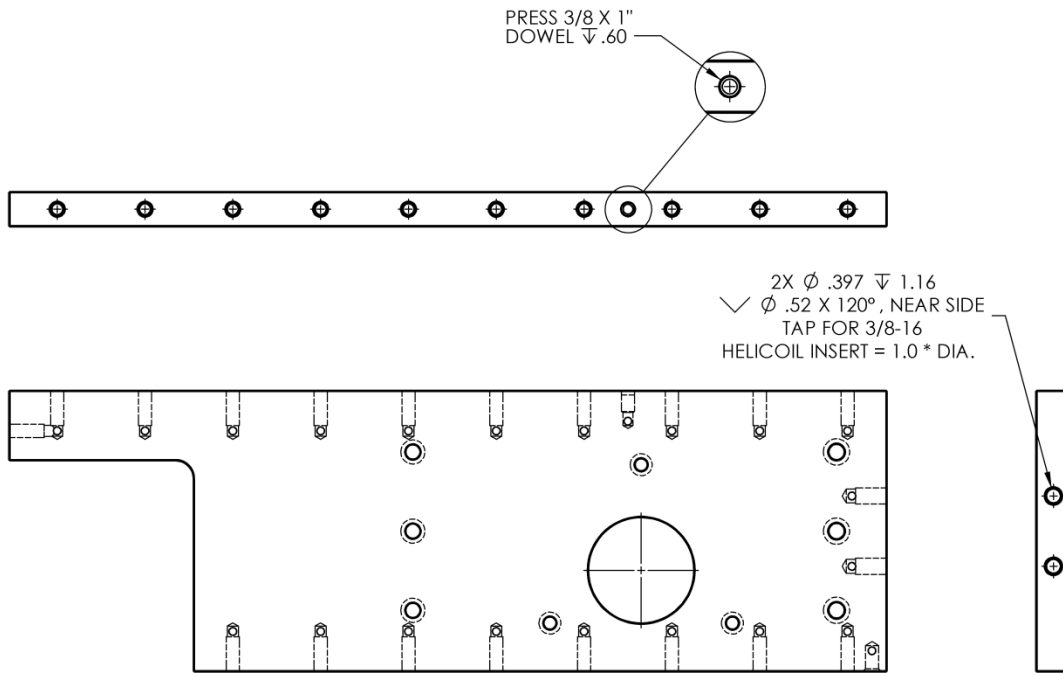

Figure 18

Preparation of D0901530:

1. Apply dowel pins as shown Figure 19.

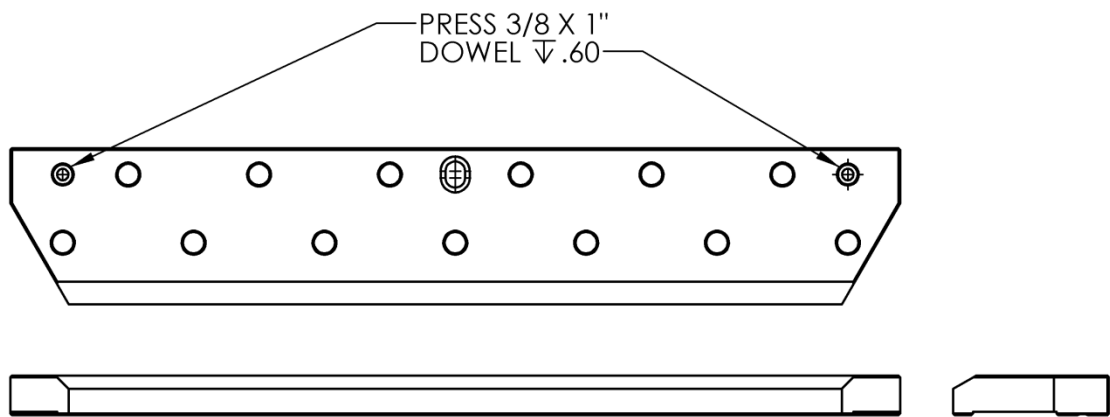

Figure 19

Preparation of D0901531:

1. Apply dowel pins as shown Figure 20.

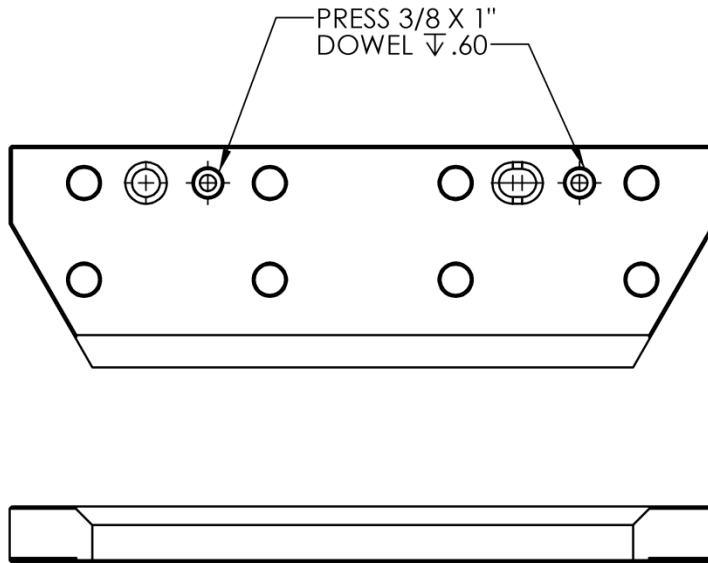

Figure 20

Preparation of D0901532:

1. Apply dowel pins as shown Figure 21. Dowels must be inserted straight, they will extend out by 3 inches.

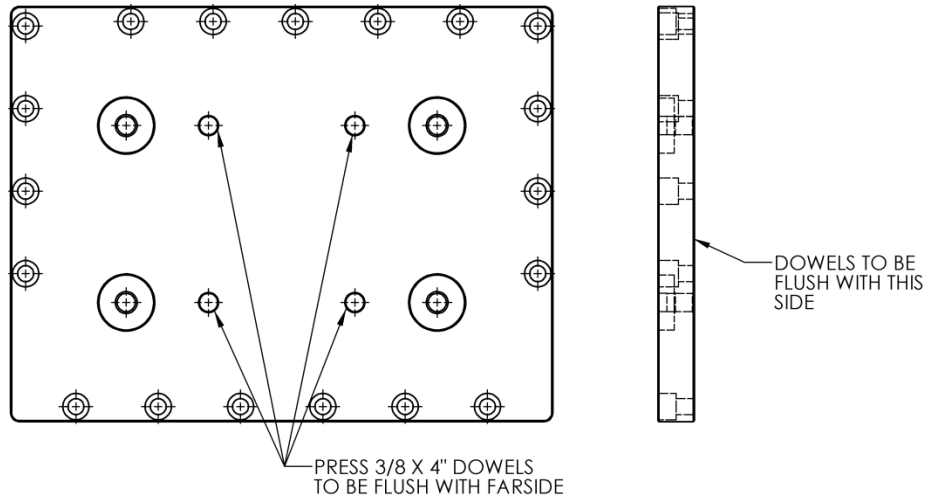

Figure 21

Preparation of D0901533:

1. Apply Helicoils and dowel pins as shown Figure 22. Dowels must be inserted straight, they will extend out by 3 inches.

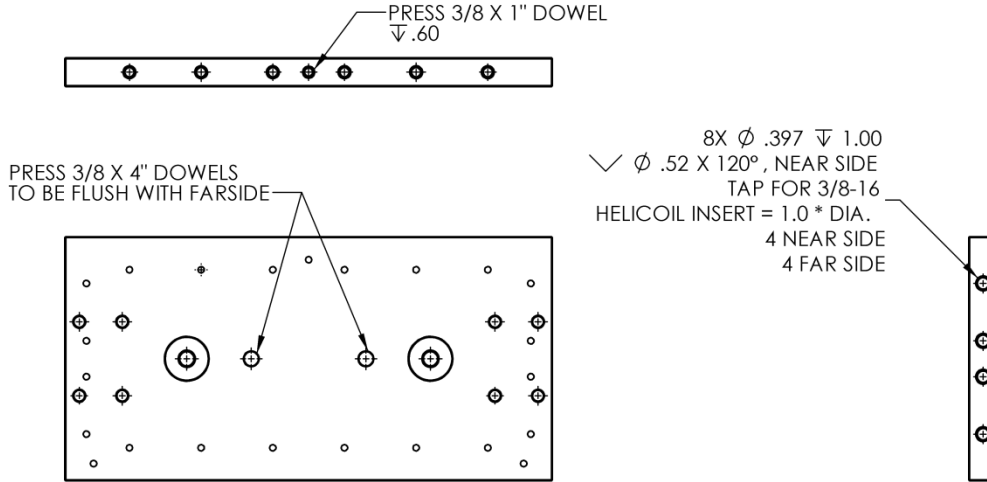

Figure 22

Preparation of D0901535:

1. Apply Helicoils and dowel pins as shown Figure 23. Note: insert dowels on side opposite counter bores.

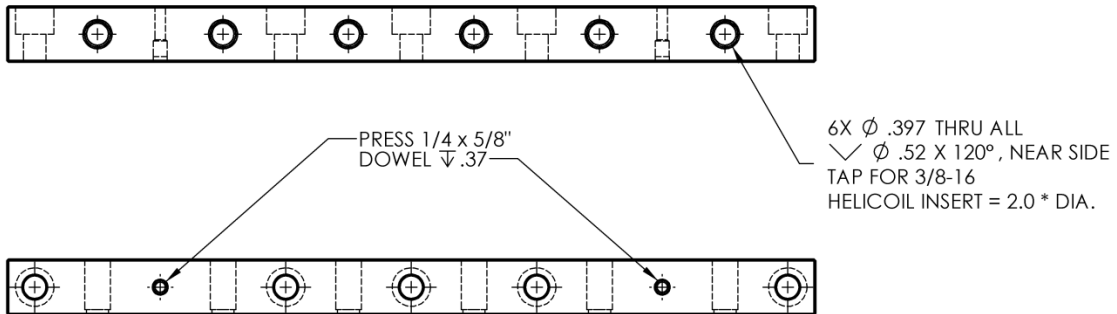

Figure 23

Preparation of D0901536:

1. Apply Helicoils and dowel pins as shown Figure 24. Note: insert dowels on side opposite counter bores.

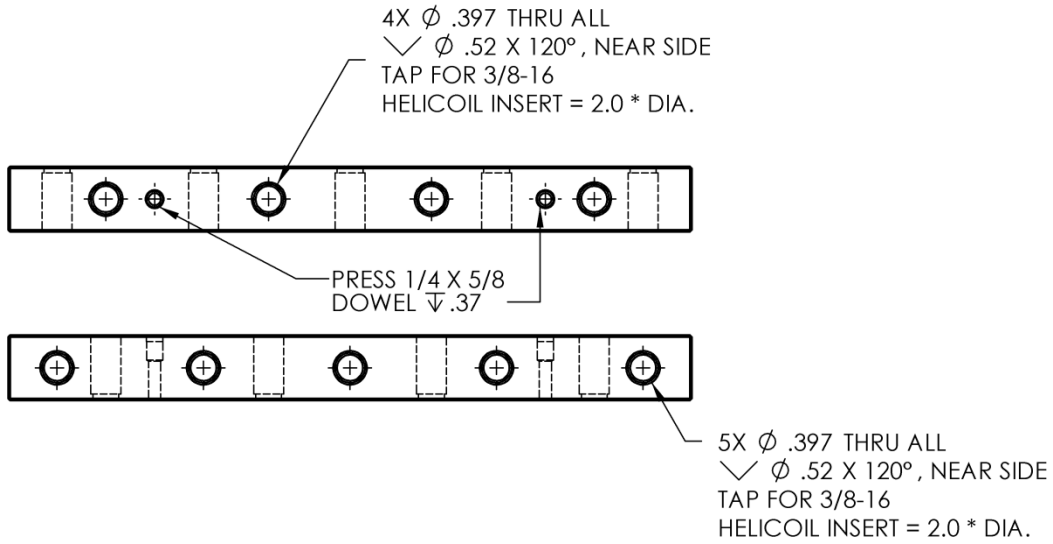

Figure 24

Preparation of D0901537:

1. Apply Helicoils as shown Figure 25.

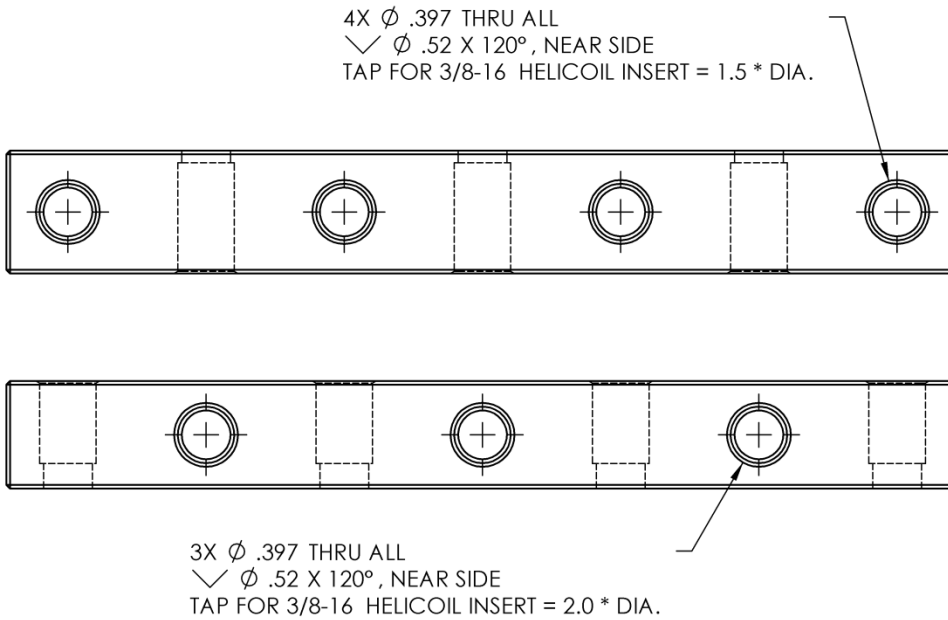

Figure 25

Preparation of D0902274:

1. Apply Helicoils and dowel pins as shown Figure 26. Note press depth of dowel.

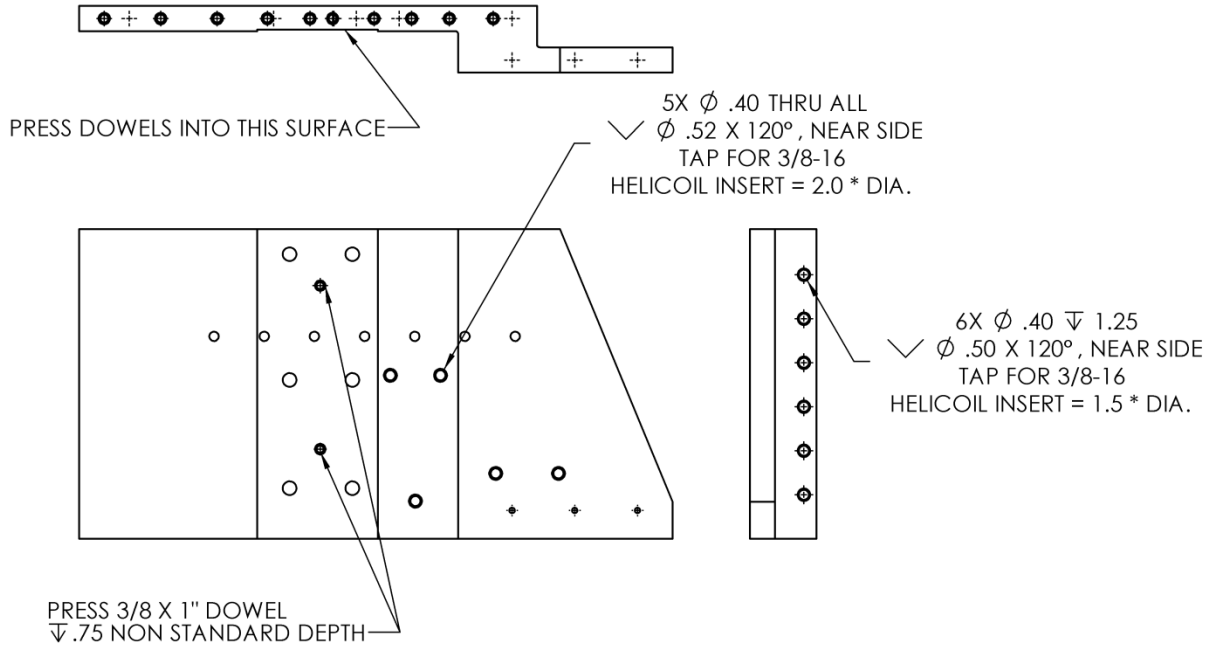

Figure 26

Preparation of D0902276:

1. Apply Helicoils as shown Figure 27.

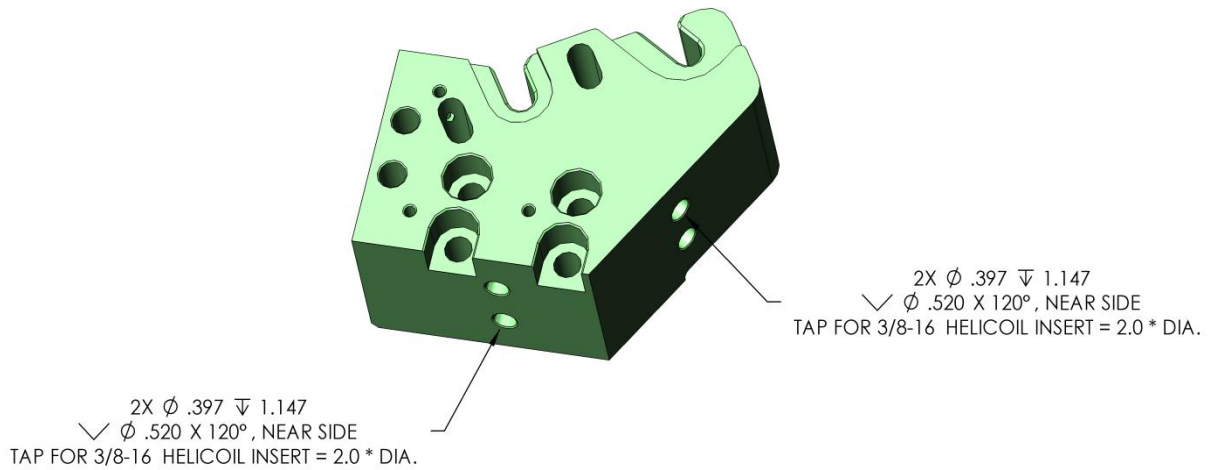

Figure 27

Preparation of D0902277:

1. Apply Helicoils and dowels as shown Figure 28. Note press depth of dowel pins

6X \varnothing .33 THRU ALL
 \sphericalangle \varnothing .44 X 90°, NEAR SIDE
TAP FOR 5/16-18 HELICOIL INSERT = 2.5 * DIA.

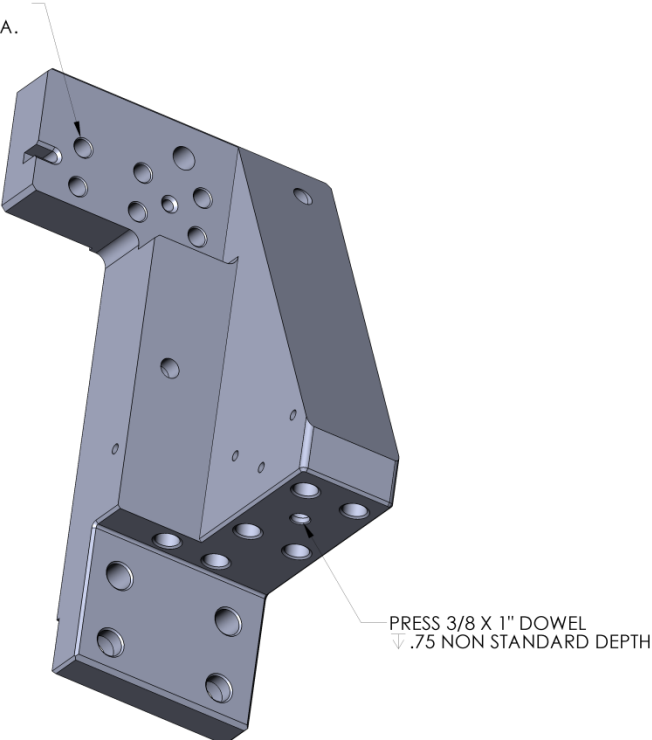

Figure 28

Preparation of D0902278:

1. Apply Helicoils and dowels as shown Figure 29. Note press depth of dowel pins

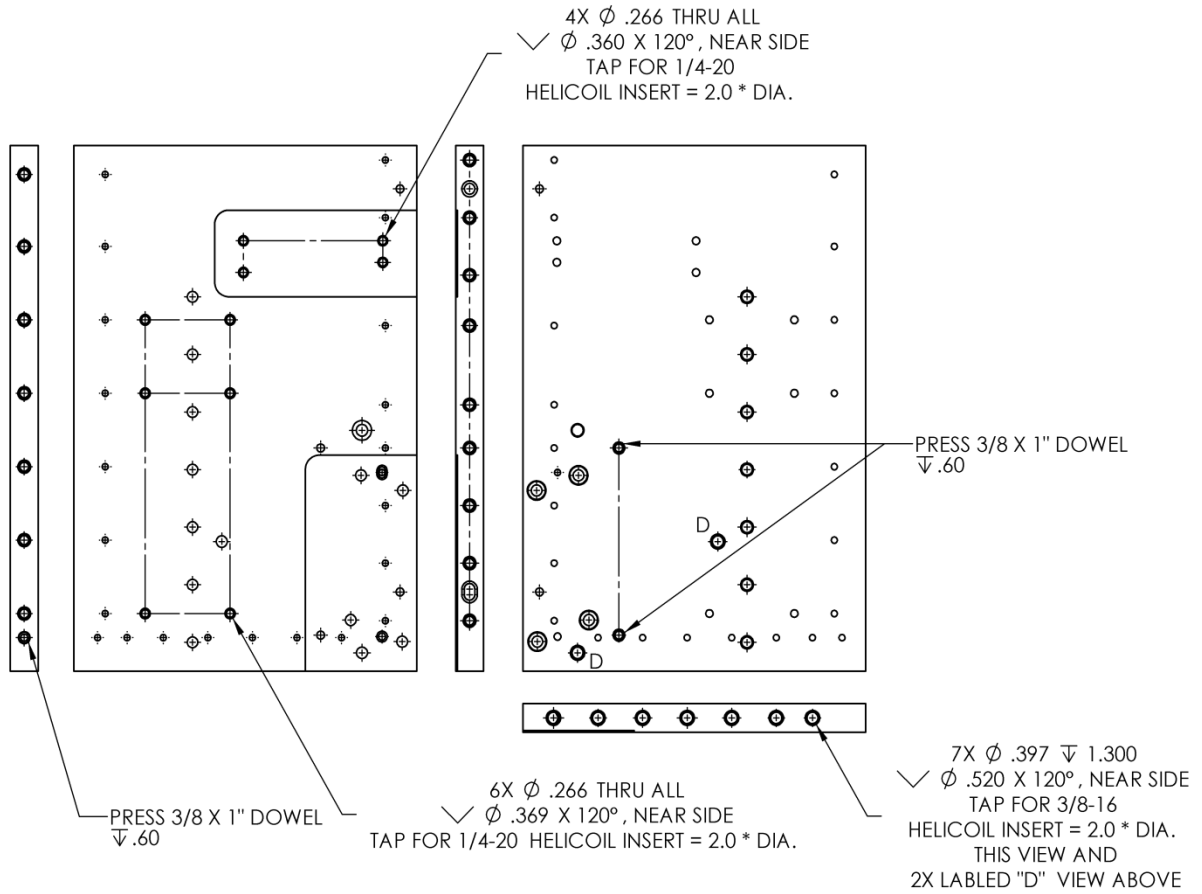

Figure 29

Preparation of D0902281:

1. Apply Helicoils and dowels as shown Figure 30. Note press depth of dowel pins and must be inserted straight.

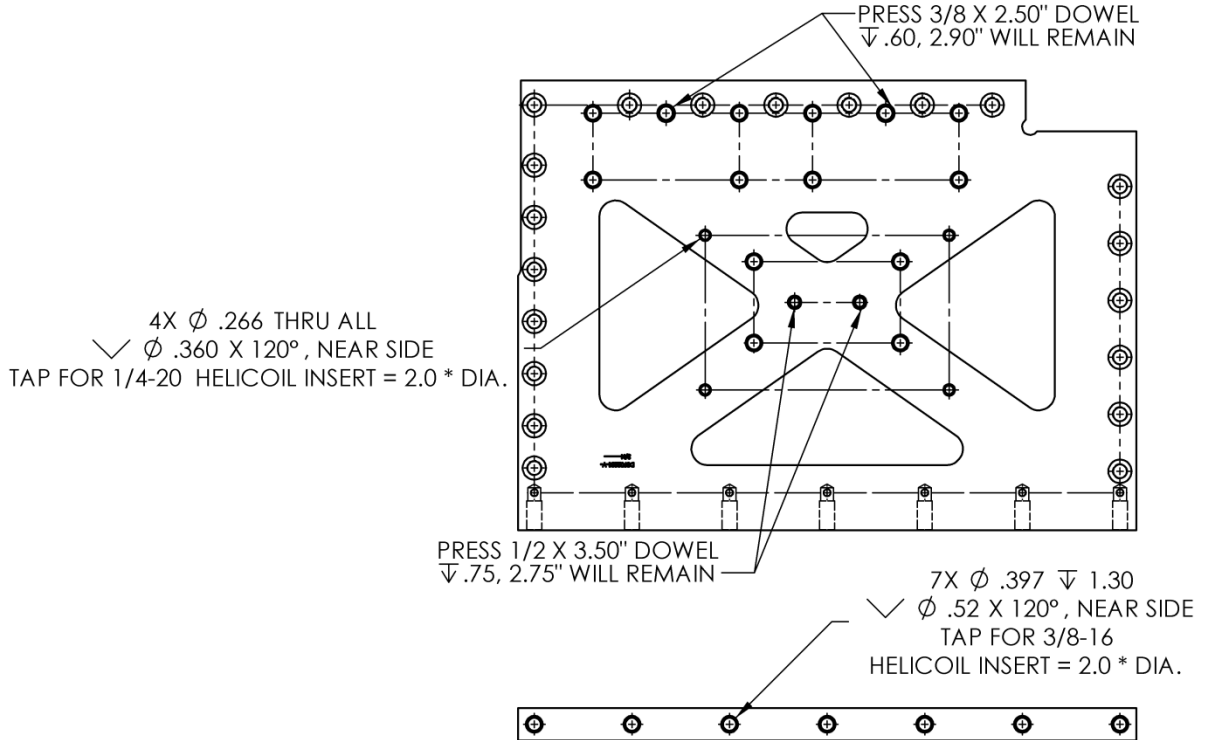

Figure 30

Preparation of D0901554:

1. Apply Helicoils as shown Figure 31.

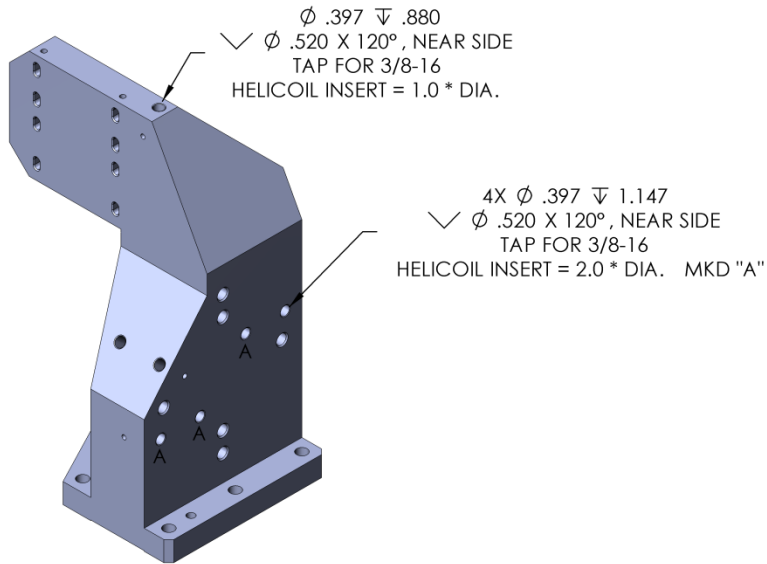

Figure 31

Preparation of D1100564:

1. Press dowel pins as shown in Figure 32

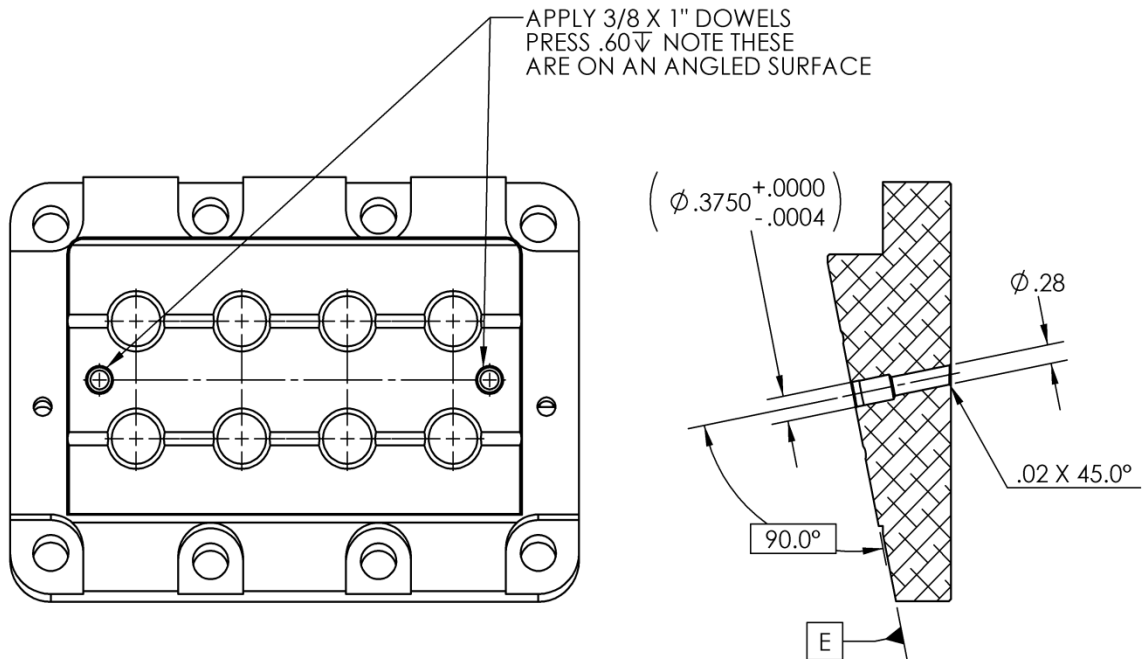
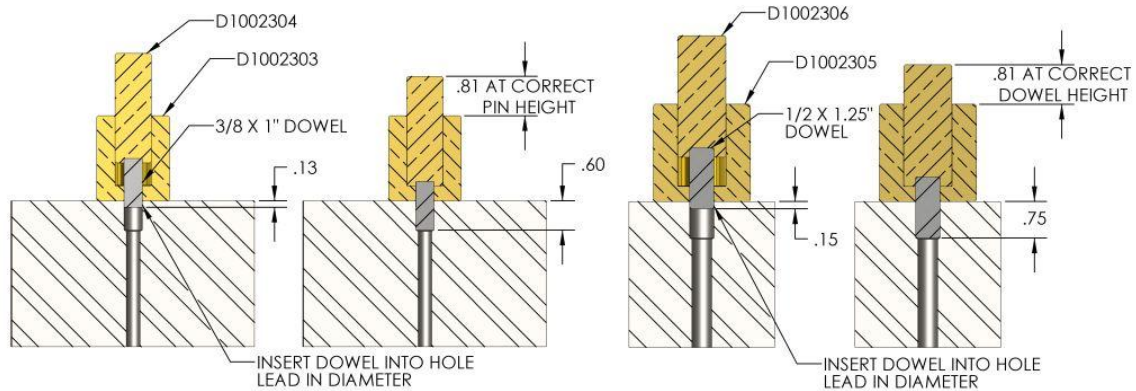

Figure 32

Appendix C: helicoils and dowel pin insertion and required tooling for hammering technique



for 1/2 x 1.25 dowel pin insert as shown Press dowel .75 in deep (dowel should bottom out) and .50 in should remain above surface. NOTE D1002306 HAS 1 MARK THE DOWEL WILL BE PROPELY SEATED WHEN IT LINES UP WITH THE TOP

for 3/8 x 1.00 dowel pin insert as shown (dowel should bottom out) and .40 in should remain above surface NOTE D1002304 HAS 2 MARKS THE DOWEL WILL BE PROPELY SEATED WHEN THE FIRST MARK LINES UP WITH THE TOP.