

**HEPI Assembly and Installation Procedures**

APPROVALS	DATE	REV	DCN NO.	BY	CHECK	DCC	DATE
AUTHOR: Kenneth Mason / Oddvar Spjeld	2/23/04	B	E040053	K.M, O.S.			
CHECKED: Kenneth Mason	2/23/04						
APPROVED: R. Abbott, D. Coyne, B. Lantz							
DCC RELEASE							

1. SCOPE

The purpose of this document is to provide step-by-step assembly instructions to be used for the site installation of the hydraulic pre-isolator (HEPI) on HAM and BSC chambers.

2. APPLICABLE DOCUMENTS

Listed below are all of the applicable and referenced documents for this task procedure.

D040001 LIGO BSC Top Assembly
D040002 LIGO HAM Top Assembly
D030278 BSC Hydraulic Pre-Isolator Assembly
D020124 HAM Hydraulic Pre-Isolator Assembly
D030690 HEPI General Assembly
D030326 EPI Crossbeam Attachment Assembly
D020284 Hydraulic Actuator
D020375 EPI Pneumatic Lift Assembly
D972128 BSC Support Pier
D030320 EPI Spring Assembly
D030322 EPI Caging Brace Assembly
D030339 EPI Horizontal Actuator Assembly
D030340 EPI Vertical Actuator Assembly
D030367 EPI Double, Straight and Offset Clamp Assembly
D030575 Unified Hydraulic Actuator Bracket Assembly
D040066 HAM Boot Installation Assembly
D040067 BSC Boot Installation Assembly
D040078 BSC Lifting Plate
D040083 BSC Pier – Housing Holes Template
D040091 HAM Lifting Plate
E040043 BSC Housing Location Procedure
E040049 BSC Lifting Procedure
E040050 HAM Lifting Procedure

3. TORQUE TABLE

Size	Torque (ft-lbs)	Torque (in-lbs)
1/4-20	12.5	150
5/16-18	20	240
3/8-16	30	360
1/2-20	40	480
3/4-20	80	960



HEPI Assembly and Installation Procedures

4. HYDRAULIC ACTUATOR PRE-INSTALLATION CHECKLIST

1. The hydraulic actuator will arrive from the supplier assembled and leak checked. Remove the actuator from the shipping container and visually inspect the actuator for damage in shipping.
2. Check that the tripod top plate (D020369) is parallel to the tripod base (D020371). The distance between the two plates should be evenly 3.1375" +/- .0035". If this tolerance is not met, straighten out the top plate or discard.
3. Check the thread quality of the actuator side-plates mounting holes to make sure a 1/2-20 screw easily can be attached.
4. Check the condition of the manifold (D020300). The area where the Parker control valve attaches should have a surface finish RMS 16 or better. There must be no scratches in the area of the O-ring seats. Remove pin valves and check the condition and cleanliness of the O-rings. Install the oil catch (D020303) along the length of the manifold.
5. Check that the tripod is properly secured with (3) .100 slotted spacers between the tripod base and the upper plate.
6. Check that there is a .06" + .01 / -.01" gap between the bellow shields and the actuator plate. A .05" gap is acceptable. The shields should be tightened flush against the top and bottom plates.

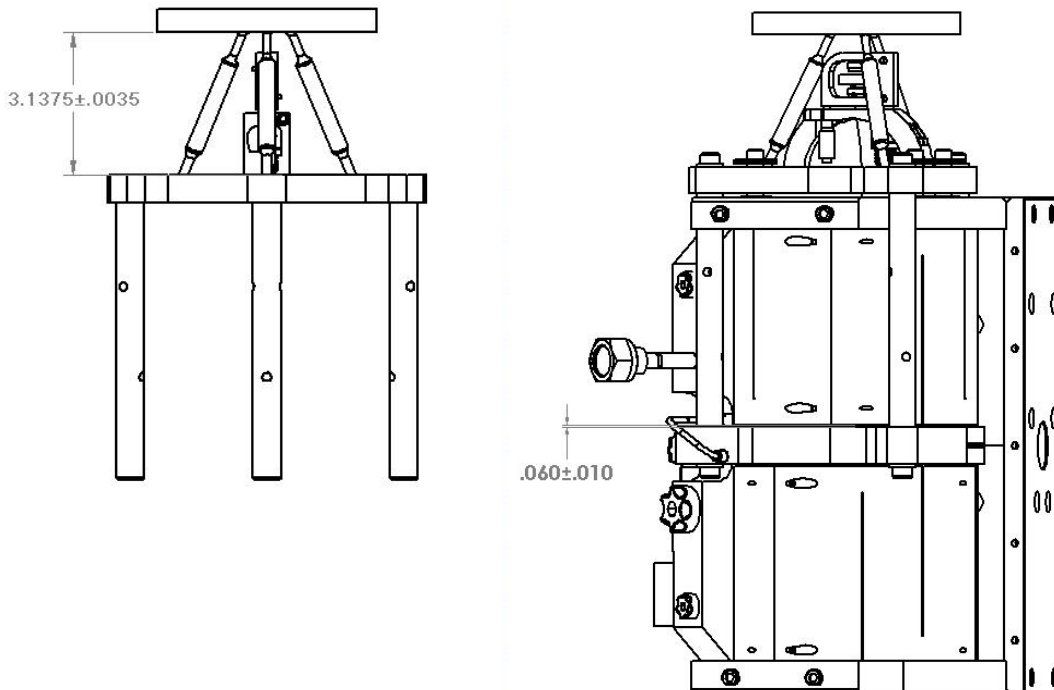

Reference drawing(s): D020284 Hydraulic Actuator



HEPI Assembly and Installation Procedures

5. HORIZONTAL HYDRAULIC ACTUATOR ASSEMBLY

1. Follow the steps in Section 4 – Hydraulic Actuator Pre-installation Checklist before proceeding.
2. Place the horizontal actuator assembly (D020384) in an upright position on a secure surface.
3. Attach (2) unified bracket assemblies (D030575) to the horizontal actuator as shown below. Use (4) ½-20 x 1.00” SHC screws. Hand-tighten screws to the actuator side plates with brackets in approximate positions as shown below.

NOTE: When assembling a horizontal actuator for the **RIGHT** housing side, use the shortened base unified bracket.

4. Attach the spherical washer housing (D020011) to the actuator attachment plate as shown below. Use (3) ½-20 x 2.50” SHC screws. Temporarily secure the spherical washer housing in place with (3) SAE ½-20 nuts.
5. Carefully store the assemblies in a safe place, being careful not to place stress on the bellows or tripod assemblies.

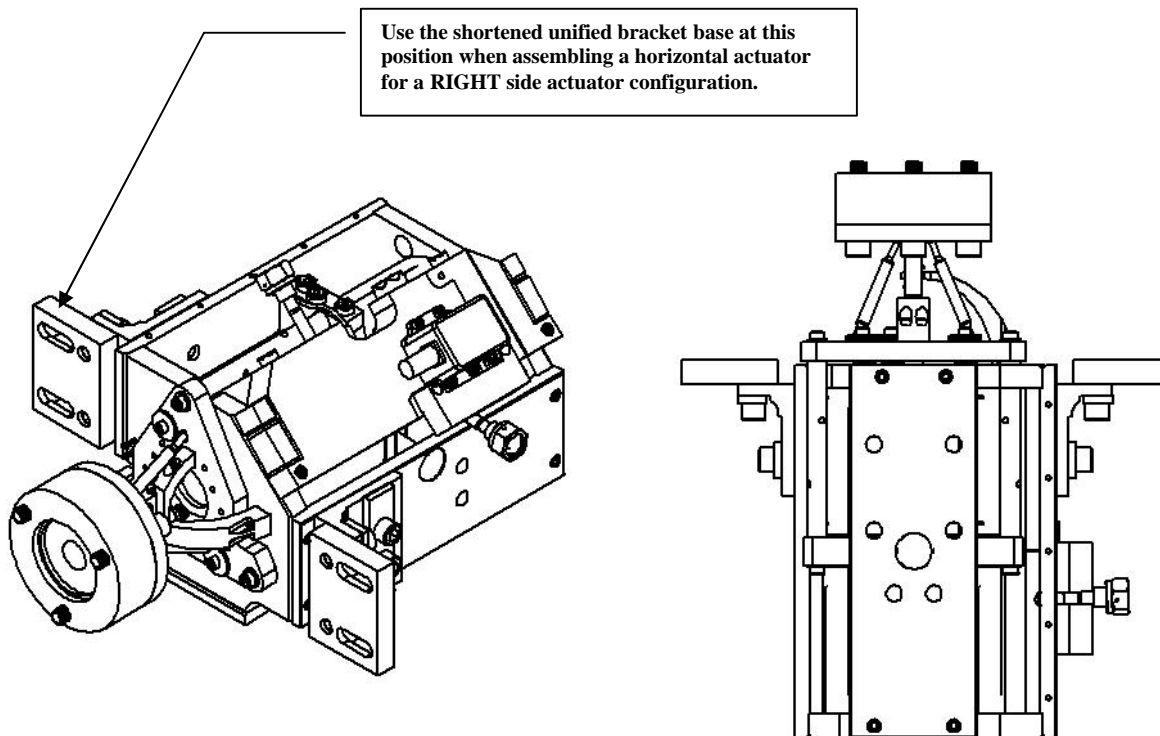
**Required Hardware**

(1) x Actuator w/ tripod and valve
 (1) x Spherical Housing
 (1) x Unified Bracket
 (1) x Unified Bracket (Short Cut)

Required Fasteners

(4) x ½-20 x 1.00” SHCS
 (4) x ½-20 x 1.25” SHCS
 (3) x ½-20 x 2.50” SHCS
 (3) x ½-20 SAE Nuts (temp.)

Reference drawing(s): D030339 EPI Horizontal Actuator Assembly



HEPI Assembly and Installation Procedures

6. VERTICAL HYDRAULIC ACTUATOR ASSEMBLY

1. Follow the steps in Section 4 – Hydraulic Actuator Pre-installation Checklist before proceeding.
2. Place the vertical actuator assembly (D020384) in an upright position on a secure surface.
3. Attach (3) unified bracket assemblies (D030575) to the vertical actuator. One of the three brackets should have a shortened base as shown below. Hand-tighten screws to the actuator side plates with brackets in approximate positions as shown below.
4. Carefully store the assemblies in a safe place, being careful not to place stress on the bellows or tripod assemblies.

NOTE: *The unified brackets should be mounted as far up as possible on the actuator side plates before fastened such that the bottom of the vertical actuator initially is lower than the bottom of the housing.*

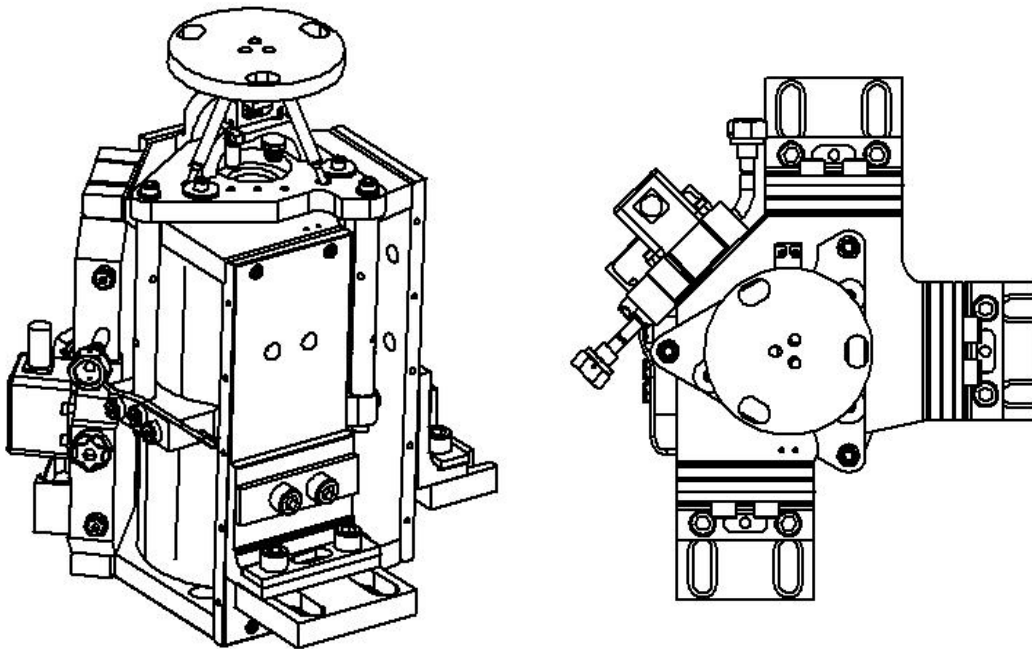

Required Hardware	Required Fasteners
(1) x Actuator w/ tripod and valve	(6) x 1/2-20 x 1.00" SHCS
(2) x Unified Bracket	(6) x 1/2-20 x 1.25" SHCS
(1) x Unified Bracket - Short Cut	

Reference drawing(s): D030340 EPI Vertical Actuator Assembly



HEPI Assembly and Installation Procedures

7. CROSSBEAM BOOT INSTALLATION ASSEMBLY

1. Place the Crossbeam Foot (D020195) on a secure clean work-area capable of holding minimum 150 lbs.
2. Attach the HAM Attachment Plate (D030693 left) / (D030695 right) or the BSC Crossbeam Attachment Plate (D020008) to the boot. Use (6) 3/8 -16 x 1.50" SHC screws. Torque to 30 ft-lbs.
3. Attach the HAM Boot Installation Plate (D030726) or the BSC Boot Installation Plate (D030725) to the crossbeam attachment plate as shown. Use (3 - 4) 1/2-20 x 1.25" SHC screws. Firmly hand tighten.
4. Rest the face of the crossbeam attachment and the boot installation plate on the work-area and attach the vertical actuator crossbeam interface ring (D030323) to the boot as shown. Use (3) 1/4 -20 x 0.50" SHC screws. Hand-tighten.

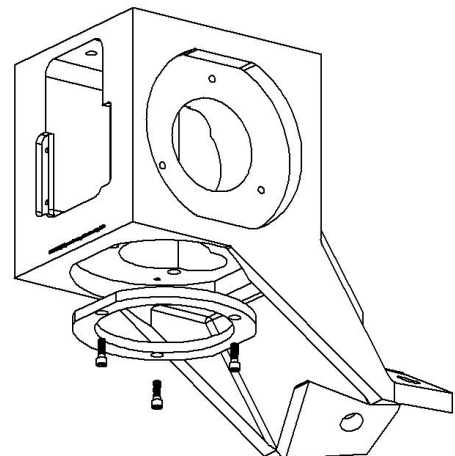
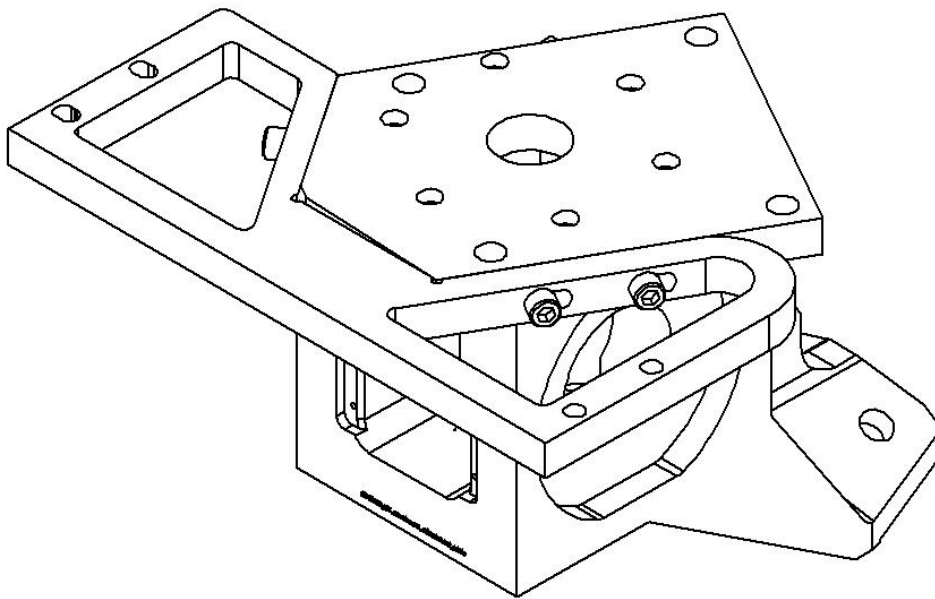

Required Hardware

- (1) x Crossbeam Foot
- (1) x HAM / BSC Attachment Plate
- (1) x HAM / BSC Installation Plate
- (1) x Vertical Actuator Interface Plt.

Required Fasteners

- (6) x 3/8-16 x 1.50" SHCS
- (3 - 4) x 1/2-20 x 1.25" SHCS
- (3) x 1/4 -20 x 0.50" SHCS

Reference drawing(s): D030326 EPI Crossbeam Foot Attachment Assembly



HEPI Assembly and Installation Procedures

8. PREPARATION OF EPI HOUSING ASSEMBLY

Step 1 – Vertical Actuator Installation

1. Prepare a work area consisting of a workbench of 1000 lb minimum load capacity and 30” wide access on each side.

Caution: Many of the parts used in this installation weigh up to several hundred pounds. Keep fingers out of pinch areas and use caution while lifting heavy objects.

2. Lift the pre-isolator housing (D020004) onto the workbench with either a crane or a hoist. Place the housing on two identical wooden beams to raise it up above the workbench surface by approximately 1-2 inches.

3. Carefully lift the Vertical Actuator Assembly (D030340) into the housing and position it as shown below. Use (6) ½-20 x 1.25” SHC screws and loosely fasten the brackets to the housing.

Caution: The actuator assembly consists of multiple highly sensitive parts that may easily be damaged therefore extra care should be taken when positioning the vertical actuator into the housing.

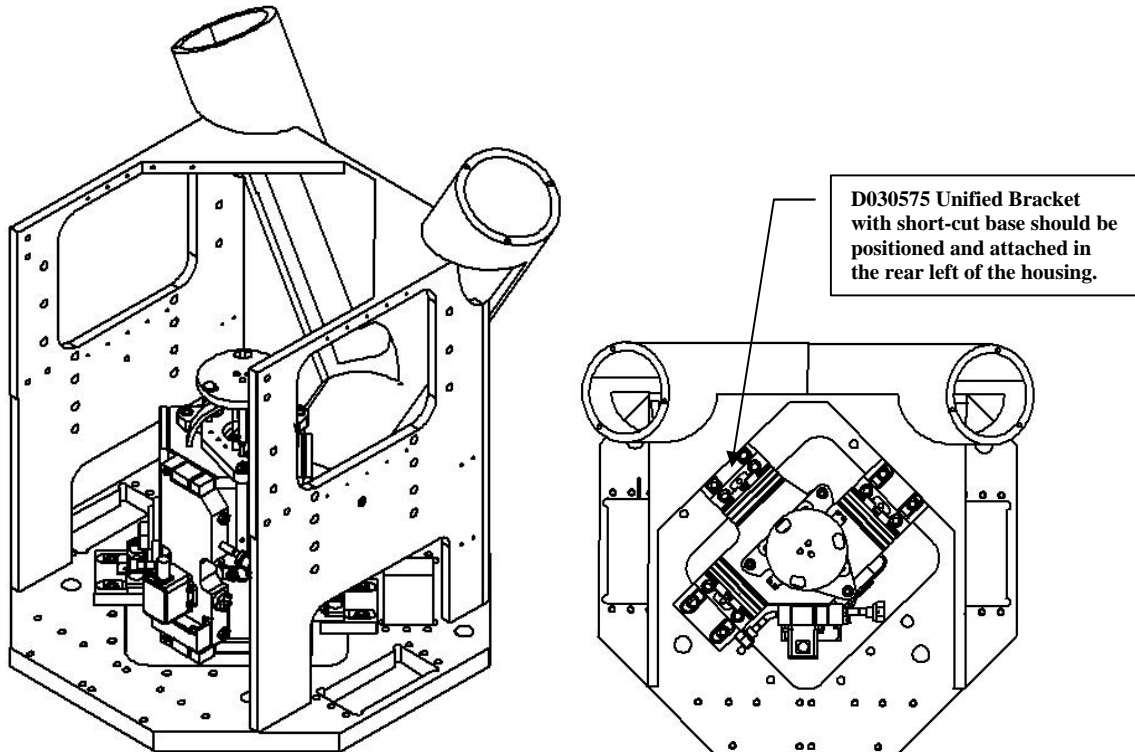

Required Hardware	Required Fasteners
(1) x Housing	(6) x 1/2-20 x 1.25” SHCS
(1) x Vertical Actuator Assembly	

Reference drawing(s): D030690 HEPI General Assembly



HEPI Assembly and Installation Procedures

Step 2 – Rear Caging Brace Installation

- Carefully lift one side of the pre-assembled Caging Brace Sub-Assembly (D030322) over the vertical actuator and attach to it the housing as shown below. Use (4) 1/2 - OD: 1.25" flat washers and (4) 1/2-13 x 1.00" Hex Head screw. Firmly hand-tighten in the position as shown.
- Insert a 1/2-20 x 1.50" Hex Head screw into the tapped hole on top of the rear caging brace. Set the height to 1.06" above the top of the plate.

Caution: Take extra care when lifting the brace over the vertical actuator tripod as it is easily damaged.

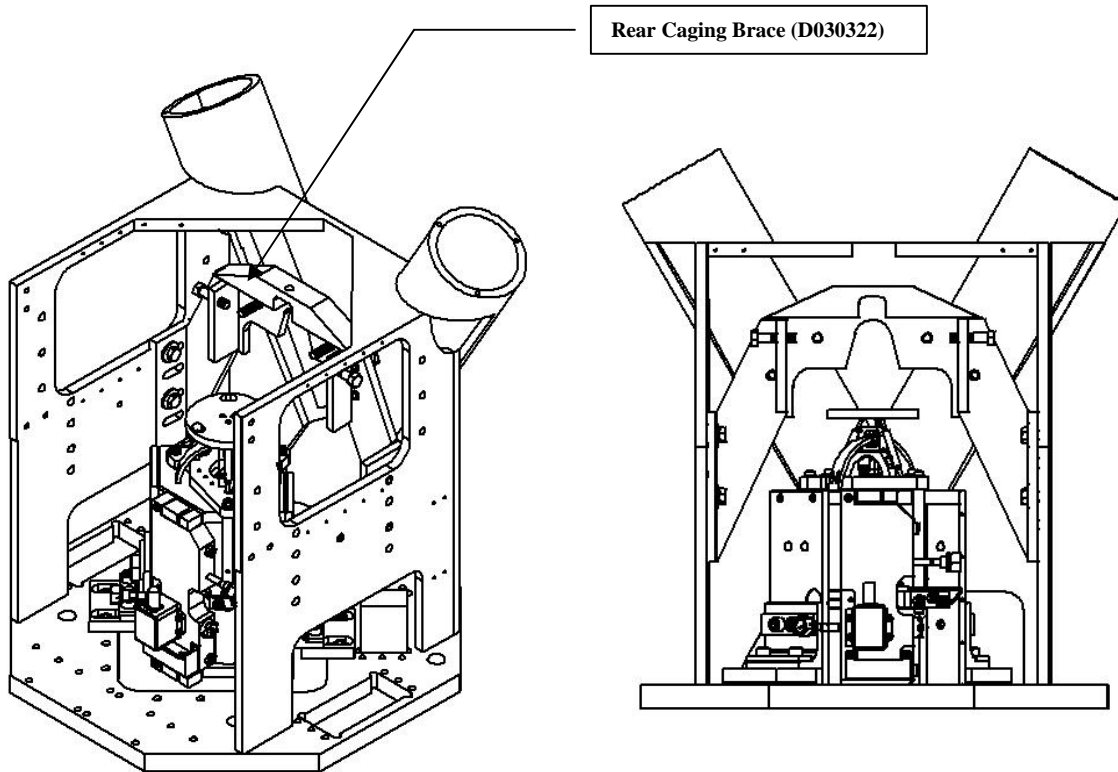

Required Hardware	Required Fasteners
(1) x Rear Caging Brace Assembly	(4) x 1/2-13 x 1.00" HEX Screws
	(4) x 1/2 OD: 1.25" flat washers

Reference drawing(s): D030322 EPI Caging Brace Assembly, D030690 HEPI General Assembly



HEPI Assembly and Installation Procedures

Step 3A – Installing the HAM Crossbeam Attachment Plate and Boot

1. Attach the Boot Installation Adjustable Support (D030728) on the left hand side of the housing. Use (3) 3/8-16 x 1.25" SHC screws. Firmly tighten.
2. Attach the Boot Installation Fixed Support (D030727) on the right hand side of the housing. Use (3) 3/8-16 x 1.25" SHC screws. Firmly tighten.
3. Lift the HAM Boot Installation Fixture Assembly with the attachment plate and boot carefully onto the top of the boot installation supports and the rear caging brace as shown.
4. Attach the boot installation plate to the supports. Use (4) 1/2-20 x 1.50" SHC screws. Firmly tighten.
5. Shift the vertical actuator assembly around on the housing until the tripod plate fits the clearance underneath the boot and mates up to the holes pattern in the bottom of the boot. Re-attach the vertical actuator to the housing in this position. Use (6) 1/2-20 x 1.25" SHC screws. Firmly tighten. **Note: Do not attach the vertical actuator to the boot at this point.**

Note: Turn over the HAM Boot Installation Plate (D030726) for installation of left and right HAM configurations.

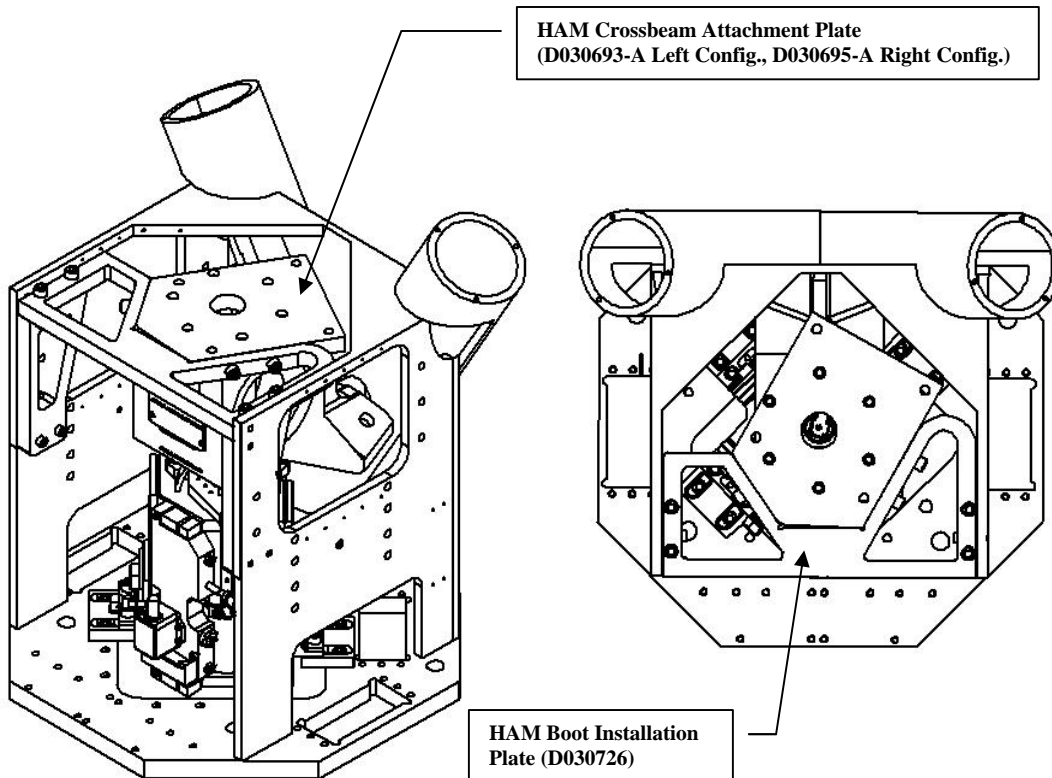

Required Hardware

- (1) x Boot Installation Assembly
- (1) x Installation Adjust. Support
- (1) x Installation Fixed Support

Required Fasteners

- (6) x 3/8-16 x 1.25" SHCS
- (6) x 1/2-20 x 1.25" SHCS
- (4) x 1/2-20 x 1.50" SHCS

Reference drawing(s): D030690 HEPI General Assembly, D040066 HAM Boot Installation Assembly



HEPI Assembly and Installation Procedures

Step 3B – Installing the BSC Crossbeam Attachment Plate and Boot

1. Attach the Boot Installation Adjustable Support (D030728) on the left hand side of the housing. Use (3) 3/8-16 x 1.25" SHC screws. Firmly tighten.
2. Attach the Boot Installation Fixed Support (D030727) on the right hand side of the housing. Use (3) 3/8-16 x 1.25" SHC screws. Firmly tighten.
3. Lift the BSC Boot Installation Fixture Assembly with the attachment plate and boot carefully onto the top of the boot installation supports and the rear caging brace as shown.
4. Attach the boot installation plate to the supports. Use (4) 1/2-20 x 1.50" SHC screws. Firmly tighten.
5. Shift the vertical actuator assembly around on the housing until the tripod plate fits the clearance underneath the boot and mates up to the holes pattern in the bottom of the boot. Re-attach the vertical actuator to the housing in this position. Use (6) 1/2-20 x 1.25" SHC screws. Firmly tighten. **Note: Do not attach the vertical actuator to the boot at this point.**

Note: Turn over the HAM Boot Installation Plate (D030726) for installation of left and right HAM configurations.

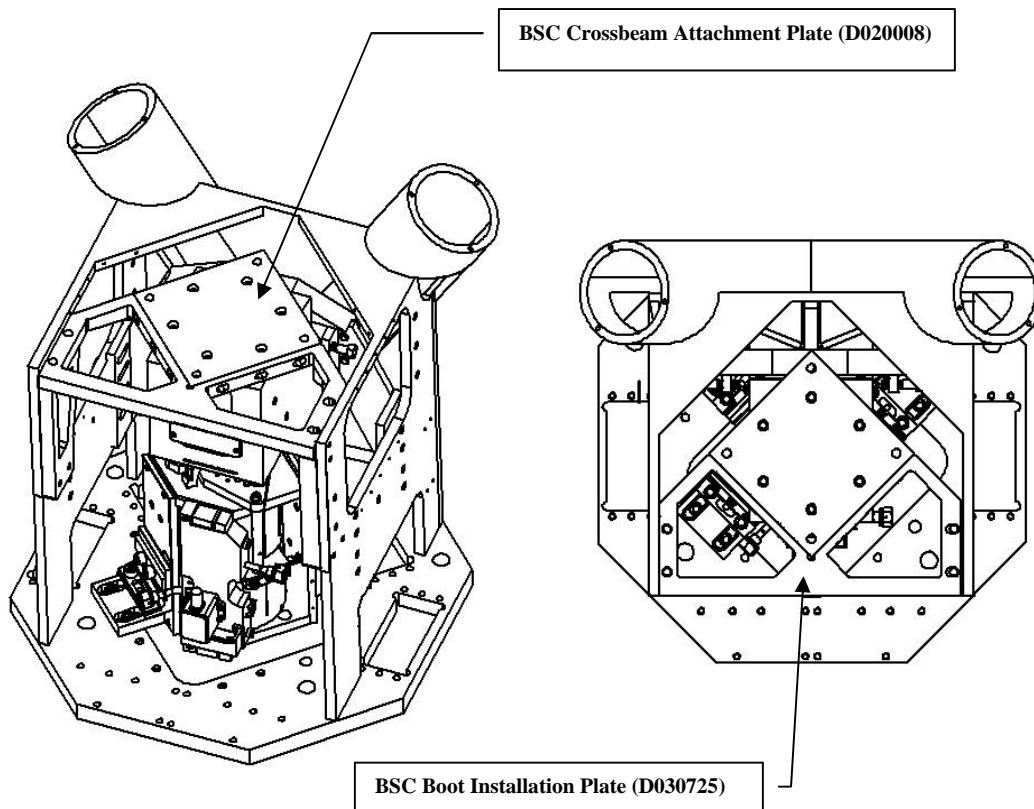

Required Hardware	Required Fasteners
(1) x Boot Installation Assembly	(6) x 3/8-16 x 1.25" SHCS
(1) x Installation Adjust. Support	(6) x 1/2-20 x 1.25" SHCS
(1) x Installation Fixed Support	(4) x 1/2 -20 x 1.50" SHCS

Reference drawing(s): D030690 HEPI General Assembly, D040066 HAM Boot Installation Assembly



HEPI Assembly and Installation Procedures

Step 4 – Spring Installation

1. Attach the spring plate (D020002) to the housing tube. Use (3) 1/2-28 x 1.50 SHC screws. Torque to 12.5 ft-lbs.
2. Place a 3/4" spherical washer set and a boot nut (D030786) on one end of each of the (2) machined spring assemblies (D020408) in a distance 2.25" from the end of the spring.
2. Slide the spring with the boot nut facing down into the tube in the housing and thru the .88" diameter holes in the boot. Attach a 7/8" spherical washer set and a boot nut (D030786) to the bottom of each spring.
3. Adjust the alignment of the spring inside the tube such that the top tread spindle is centered inside the tube opening.
4. Secure all four boot nuts with the spherical washers sets pressed against the top and bottom of the boot. Torque to 80 ft-lbs.
5. Attach the spring adjust plate (D020001) to the spring plate (D020002). Use (3) 1/2-20 x 1.50" SHC screws. Torque to 40 ft-lbs. **Note: If the spring is not centered inside the spring adjust plate, loosen the lower nut and reposition the spring so that it does not touch the spring adjust plate.**
6. Place a 1 1/4" ID, 2.5 OD spherical washer set against the spring adjust plate, followed by the correct load cell (type 1.5 K for HAM and 2.0K for BSC), a flat washer and the spring nut (D020009) with the spherical surface up and the flat surface against the washer. **Note: The threads on the spring end should not touch the inside walls of the load cell when installed correctly.**

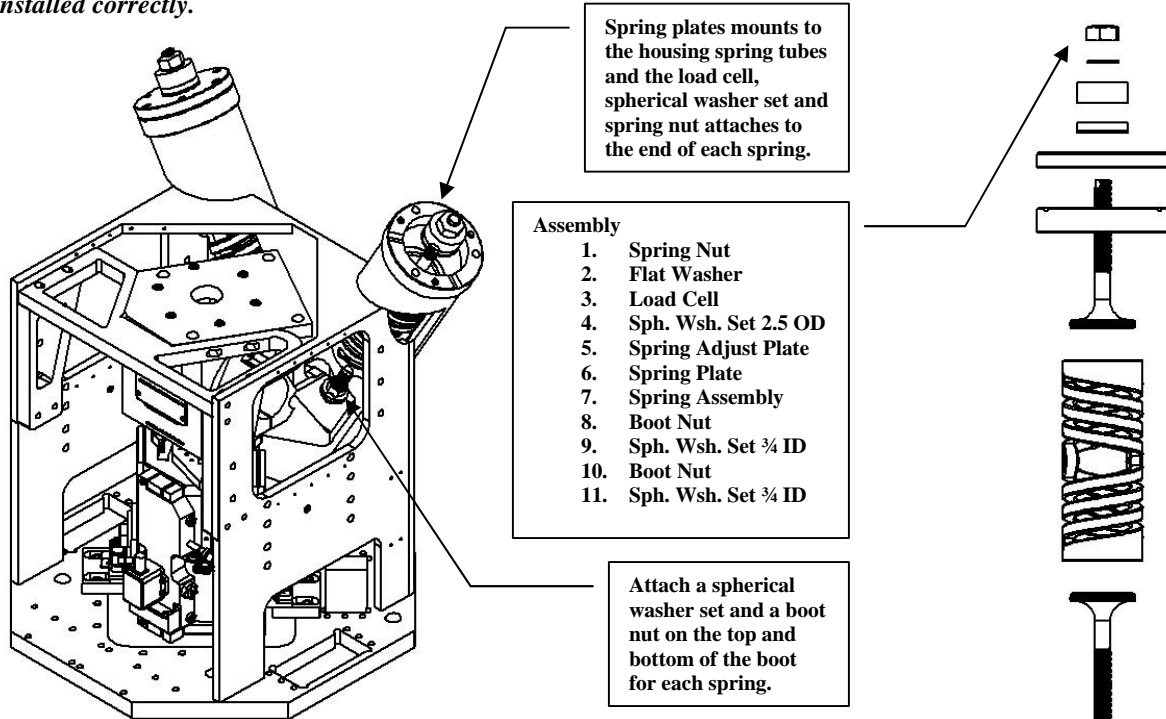

Required Hardware	Required Fasteners
(2) x Spring Assembly	(6) x 1/4 -28 x 1.50" SHCS
(2) x Spring Nut with 2.5 OD sp.wsh	(6) x 1/2-20 x 1.50" SHCS
(2) x Load Cells (HAM or BSC)	(4) x Boot Nut with 3/4 ID sp. wsh

Reference drawing(s): D030690 HEPI General Assembly, D030320 EPI Spring Assembly



HEPI Assembly and Installation Procedures

9. PREPARATION FOR INSTALLATION

1. Procure the following special equipment for this task:
 - a. Load cell (dynamometer) for crane, with 6000 lb maximum range and 10 lb gradations (Eilon Engineering, RON 2000 Shackle Type, Catalog no. S-03)
 - b. Lifting Plate (BSC: D040078, HAM: D040091) with Shims, Eyebolt, Fasteners and Washer
 - c. Transfer table or fork lift, for transferring equipment between the fork lift platform and the top of the Scissors Table. (Ball rollers or Teflon sheet)
 - d. Shim blocks and crowbars for separating pinned pier stack components (if needed).
2. Coordinate task schedule with the Detector Commissioning Manager (if commissioning is occurring; otherwise, coordinate with Observatory Manager).
3. Confirm shackle/clevis fit has been checked, and machine screw jack has been reworked.
4. Confirm all equipment to be used for this task fits and is fully functional. Confirm that the transfer table is securely attached to the forklift platform, and that the forklift platform is securely attached to the forklift.
5. Setup beam monitors as appropriate to monitor possible shifting of the optic(s) in the chamber being worked on. A beam monitor shall consist of an optical lever or laser autocollimator.
6. Setup dial indicators at each crossbeam end for monitoring movement in all three directions: X, Y and Z. Record direction of positive indication and zero all dials (use compass directions for Pier ID reference and direction reference).

Caution: Throughout this task, take care to not disturb the Dial Indicator mounting hardware! Take great care to not apply force or torque to the Crossbeams or anything rigidly attached to them. Do not push them, lean on or stand on them (or anything connected to them)! It is very important that the current optical alignment is not disturbed! Refer to Drawing D020280 for an illustration of the hardware for the steps to follow.

Direction of positive indication for Dial Indicators:

Pier ID: _____ X: _____ Y: _____ Z: _____

Pier ID: _____ X: _____ Y: _____ Z: _____

Pier ID: _____ X: _____ Y: _____ Z: _____

Pier ID: _____ X: _____ Y: _____ Z: _____

Confirmation of Zeros:

Pier ID: _____ X: _____ Y: _____ Z: _____

Pier ID: _____ X: _____ Y: _____ Z: _____

Pier ID: _____ X: _____ Y: _____ Z: _____

Pier ID: _____ X: _____ Y: _____ Z: _____



HEPI Assembly and Installation Procedures

- Follow the step-by-step instructions in the BSC Lifting Procedure (E040049) / HAM Lifting Procedure (E040050).
- Connect the shackle to the crane and lift to remove excess length. Stop if you see any load being transferred to the load cell.
- Remove the (4) 1/2-13 SHCS connecting the crossbeam to the air-bearing adapter.
- Using the machine screw jack, apply load to the crane hook. As you lift, watch the vertical dial indicator at the support tube closest to the pier you are lifting. As you raise the crossbeam you will notice the dial indicator could start out reading lower then begin to rise. This is particularly true with the HAM installation. Continue to lift the crossbeam until the dial indicator reaches +0.010.

Record load cell _____ lb

Record all dial indicator positions:

Pier ID: _____ X: _____ Y: _____ Z: _____

Pier ID: _____ X: _____ Y: _____ Z: _____

Pier ID: _____ X: _____ Y: _____ Z: _____

Pier ID: _____ X: _____ Y: _____ Z: _____

- Remove air bearing assembly, the course stage assembly, and the scissor table. If the installation will be on a HAM, remove the pier plate adapter and HAM pier D972609 and proceed with steps 12 – 16. If the installation is on a BSC chamber, jump to step 17.
 - Clean the grout plate top surface of any dirt particles.
 - Position the pre-isolator pier D020126 onto the pier grout plate D972126.
 - Check the pier level with a surveyors level, scale, and stand. If out of level by more than .01 over the width of the pier, remove the pier and check again for any obstructions that are preventing the pier from sitting level.
 - Set yaw of pier by laying a flat edge across the flat on the pier to the flat on an adjacent pier.
 - Replace the 3/4" flange nuts and torque to 100 ft-lbs.
- Caution: Take great care to not apply force or torque to the Crossbeams or anything rigidly attached to them. Do not push them, lean on or stand on them (or anything connected to them)! It is very important that the current optical alignment is not disturbed.**
- Two 1/2-13 unc-2b holes must be drilled into the top of the BSC pier. Follow the step-by-step instructions in the BSC Housing Location Procedure (E040043).



HEPI Assembly and Installation Procedures

10. INSTALLATION OF EPI HOUSING ASSEMBLY TO THE PIER

1. Place a .06" thick sheet of Teflon onto the lift table and place a completed EPI Housing Assembly onto the lift. Be sure to select the correct assembly. The EPI actuators always face away from the chamber.
2. With the lift aligned to the height of the pier slide the housing until the (4) holes in the crossbeam top plate roughly line up to the crossbeam and the three holes in the base line up with the three tapped holes in the top of the pier.
3. Insert the installation sleeves (D040084) into the (2 to 4) 1.00" clearance mounting holes on the base of the housing.
4. Position the housing so that the (3 to 4) mounting holes on the housing align with the drilled and tapped 1/2-13 holes on top of the pier. Use 1/2-13 x 2.50" screws and 1/2 OD: 2.00" flat washers to attach the housing to the pier.
5. Install (2) double clamps (D020269), (1) offset clamp (D020270), and (1) straight clamp (D020271) as shown below. Use (2) 1/2-20 x 1" long set screws into the side each clamp. Tighten so that they touch the EPI housing then back off 1/2 turn.
6. The four holes in the crossbeam attachment plate should now be aligned with the holes on the crossbeam. If necessary remove the installation sleeves and slightly reposition the housing until the attachment plate can be attached to the crossbeam.

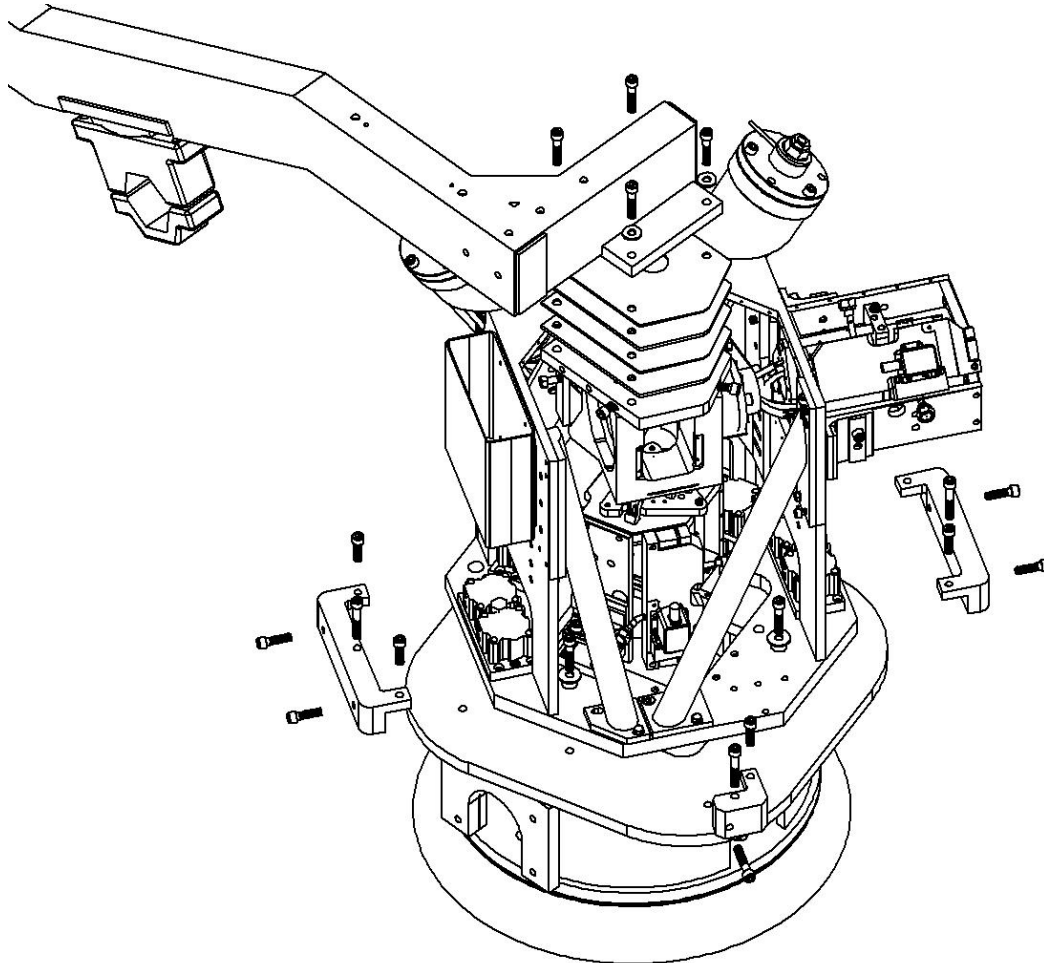



HEPI Assembly and Installation Procedures

7. Place a locator pin through the four holes in the crossbeam attaching the crossbeam to the boot attachment plate. Using the 1/2-20 screws located on the side of the 4 clamps, push the housing until all 4 pins fall through.

8. Remove the installation sleeves from the mounting holes on the housing and reattach the bolts securing it to the pier. Torque to 45 ft-lbs.

9. Measure the gaps at the four corners between the EPI top plate D020008 and the crossbeam D972612 with shims or a feeler gage and record.

Inner right gap _____
 Inner left gap _____
 Outer right gap _____
 Outer left gap _____

10. Insert required attachment plate shims (D030698 / D030699 / D030700) between the crossbeam attachment plate and the crossbeam. Use (4) 1/2-20 x 2.50" SHC screws and (4) 1/2" flat washer OD: 1.125". Hand tightens.

NOTE: If necessary custom made level shims will be machined in order to evenly mate the attachment plate to the crossbeam.

11. Back off on the 4 vertical screws holding the boot installation plate to the side braces. Tighten the (4) 1/2-20 screws in step 7 and torque to 45 ft-lbs. The weight of the boot should transfer from the installation plate to the crane.

12. Remove the installation plate and side brackets. Replace with the outer caging braces (D020250, D020276, and D020249). Make sure the stops are backed off away from the boot.



HEPI Assembly and Installation Procedures

11. LOAD CELL CALIBRATION AND STACK LOAD TRANSFER

1. Install digital readout boxes to all eight load cells. Calibrate the readout to the load cell per the manufacturers directions using calibration data supplied with each load cell.
2. Begin tightening both springs at one of the piers. Remove the jam nuts on top of the springs. Tighten the spring nuts simultaneously, maintaining an equal load on each of the load cells. Continue tightening until the vertical dial indicator closest to you reads + .010".
3. Turn the handle on the screw jack lowering the crossbeam. Continue lowering as the dial indicator passes through 0 to - .010".
4. Go back to the two spring two nuts on top of the springs and simultaneously tighten the nuts until the dial indicator rises passed 0 and reaches + .010". Continue these steps until the load cell on the crane reads 100#s. At that point switch from +/- .010" to +/- .002".
5. The load will be completely transferred to the springs when the load cell on the crane reads 0 and the dial indicator also reads 0.
6. Replace the jam nuts and tighten down to the spring nuts.
7. **IMPORTANT!** Hand tighten the (8) screws on the side of the bracing holding the boot and the (2) vertical screws holding the boot from moving before going on to the next pier.
8. Remove the lift jack and lifting plate and repeat for the remaining piers.
9. Repeat steps 8-10 above for each of the remaining piers.
10. Starting with pier 1, increase or decrease the loads equally on the springs until the dial indicators return to a z-height of 0.000. Follow a figure 8 pattern going from pier 1, pier 3, pier 4, and pier 2 then back to pier 1. Several times around may be required to bring each dial indicator to +/- .001 from 0.000.
11. Hand-tighten all horizontal and vertical stops to secure the boot.
12. Adjust the 1/2-20 pushers in each clamp to return the x and y dial indicators to their original position and the optical lever returns to its original position. Tighten all 1/2-20 set screws in the clamps.



HEPI Assembly and Installation Procedures

12. INSTALLATION OF THE HORIZONTAL ACTUATOR

1. Attach the horizontal actuator angle mount (D020016) to the housing. Use (4) 1/2-20 x 1.00" SHC screws and 1/2 OD: 2.00" flat washers. Do not tighten screws.
2. With the top of the angle bracket positioned 13.6" above the housing, lay the actuator onto the bracket as shown. Remove the 1/2 nuts temporarily securing the washer housing. Carefully slide the actuator into position against the boot.
3. Attach the horizontal actuator to the bracket. Use (4) 1/2-20 x 1.50" SHC screws and (4) 1/2 OD: 2.000 flat washers. Insert the angle mount backup plate (D030694) underneath the bracket as shown and torque screws to 40 ft-lbs.

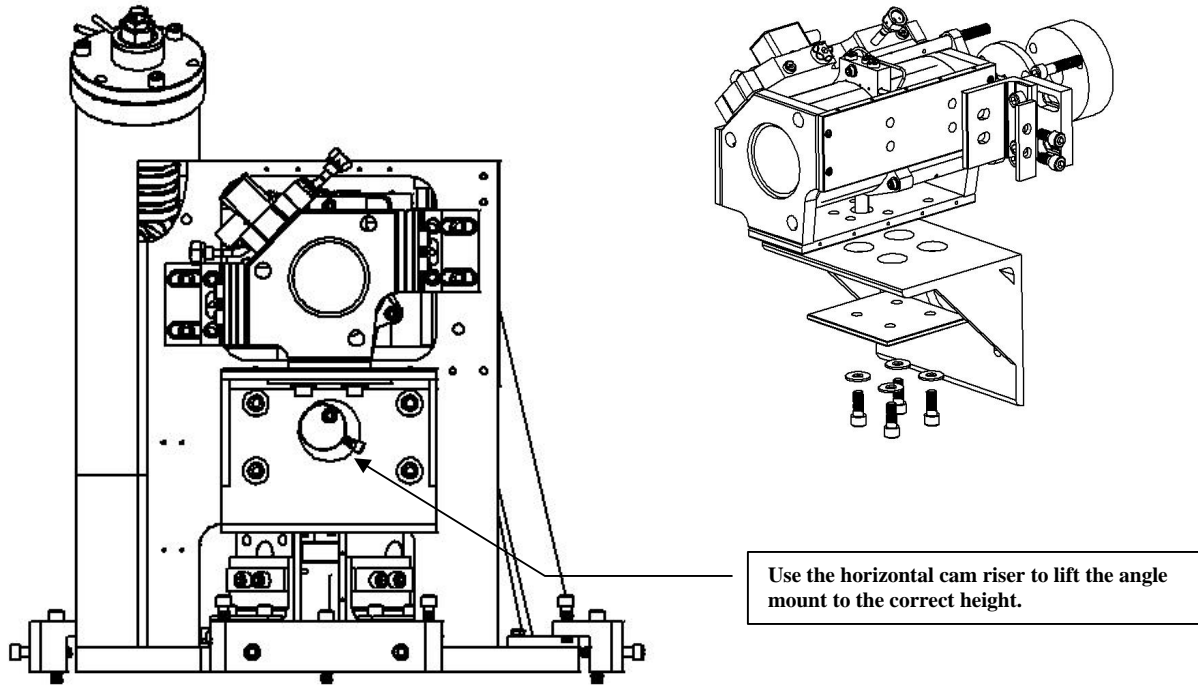

4. Attach the two unified brackets to the side of the housing. Use (2) 1/2-20 x 0.75" SHC screws in the front end of the housing and (2) 1/2-20 x 1.00" SHC screws in the rear end of the housing. Do not tighten.
5. Attach the actuator bracket riser cam (D040032) to the side of the housing using (1) 3/8-16 x 1.50" SHC screw, fit a 3/8 diameter bolt or tool through the cross-drilled tooling hole and use the cam to adjust the angle bracket to fit.
6. Fasten the tripod to the boot using the existing SHC screws. Check that the tripod is stress free and not twisted.
7. Torque the (4) SHC screws attaching the unified brackets to the housing to 40 ft-lbs.

Required Hardware	Required Fasteners
(1) x Horizontal Actuator Assembly	(2) x 1/2 -20 x 1.00" SHCS
(1) x Actuator Angle Mount	(2) x 1/2-20 x 0.75" SHCS
(1) x Angle Mount Backup Plate	(8) x 1/2-20 x 1.25" SHCS
(1) x Actuator Cam Riser	(8) x 1/2 OD: 1.063/2.000 F.W.

Reference drawing(s): D030690 HEPI General Assembly, D030339 EPI Horizontal Actuator Assembly



HEPI Assembly and Installation Procedures

13. INSTALLATION OF THE VERTICAL ACTUATOR

1. Check that all three .100" spacers are located between the actuator tripod base and the actuator top plate and the (3) screws holding them in place are tight.
2. Loosen approximately 1½ turn all six screws on each of the (3) unified bracket assemblies holding the vertical actuator to the housing.
3. Lift the actuator and attach (3) ½-20 x 1.25" and (3) ½" OD: 1.063" flat washers that secure the actuator to the boot. Torque to 40 ft lbs. At this point all of the weight of the actuator is hanging from the boot.
4. Slide the brackets until all three-bracket assemblies are seated properly with no gaps between mating surfaces. If gaps occur, shim as required. Tighten down all bolts securing the vertical actuator to the housing.
5. Remove the tripod stops and .100" shims from the actuator. Check that the .100" gap is maintained and that the gaps between the bellows shield and the actuator plate are maintained at .060" +/- .010". If these measurements are not correct insert a jacking screw into the center hole in each bracket and loosen the screws.
6. Adjust the jacking screws until the .100" gap and the two .060" +/- .010 gaps are attained. Shim any angular mismatches and tighten screws to maintain correct gaps.

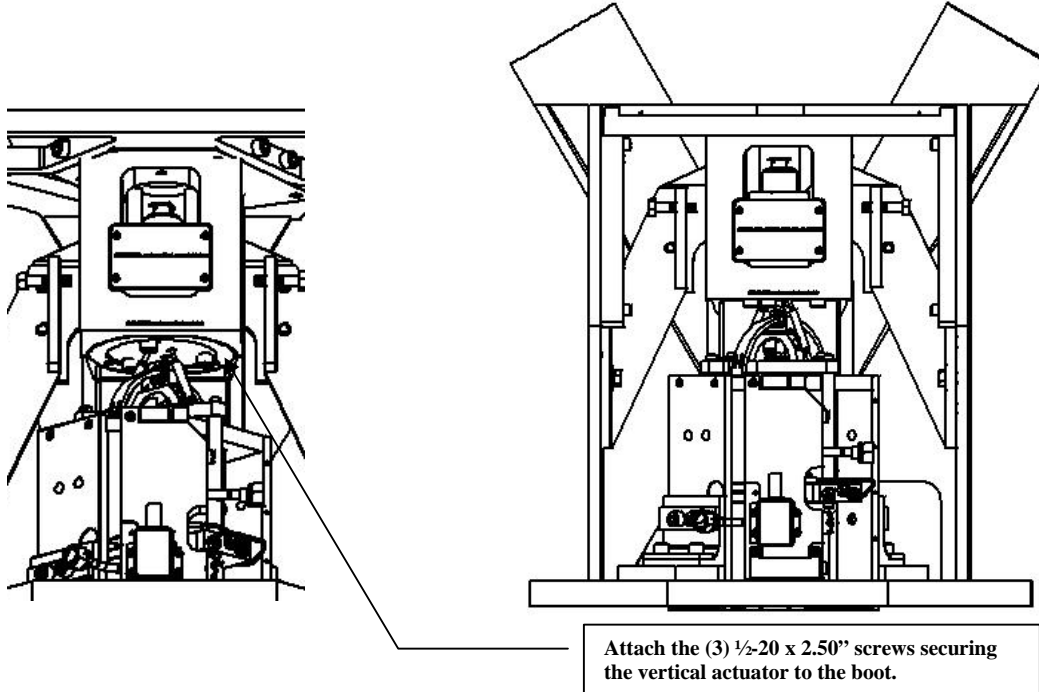

Required Hardware	Required Fasteners
(1) x Vertical Actuator Assembly	(3) x ½ -20 x 1.25" SHCS
	(3) x ½ OD: 1.063" flat washer

Reference drawing(s): D030690 HEPI General Assembly, D030340 EPI Vertical Actuator Assembly



HEPI Assembly and Installation Procedures

14. FINAL ASSEMBLY AND ALIGNMENT

1. Remove the (3) .100" spacers placed between the tripod base and actuator face plate.
2. Carefully insert the vertical L4-C into the front of the boot until it rests on the top of the vertical actuator tripod plate. Attach the Crossbeam Foot Sensor Hold-down (D030325) to the boot as shown. This will clamp the vertical L4-C to the boot. Use (4) 8-32 x 0.375" SHC screws. Firmly tighten.

Caution: *The vertical L4-C must always be handled in a horizontal position (inactive state) until it is installed.*

3. Position the (2) 1/4-20 x 1.50" SHC clamp screws into the Horizontal L4-C Mount (D030586) and carefully insert the horizontal L4-C into the mount as shown. The base of the L4-C should be positioned flush with the end of the bracket. Use the clamp screws to secure the L4-C in this position.
4. Attach the horizontal L4-C mount with the L4-C secured to the side of the boot as shown. Use (3) 1/4-20 x 1.50" SHC screws. Torque to 12.5 ft-lbs.

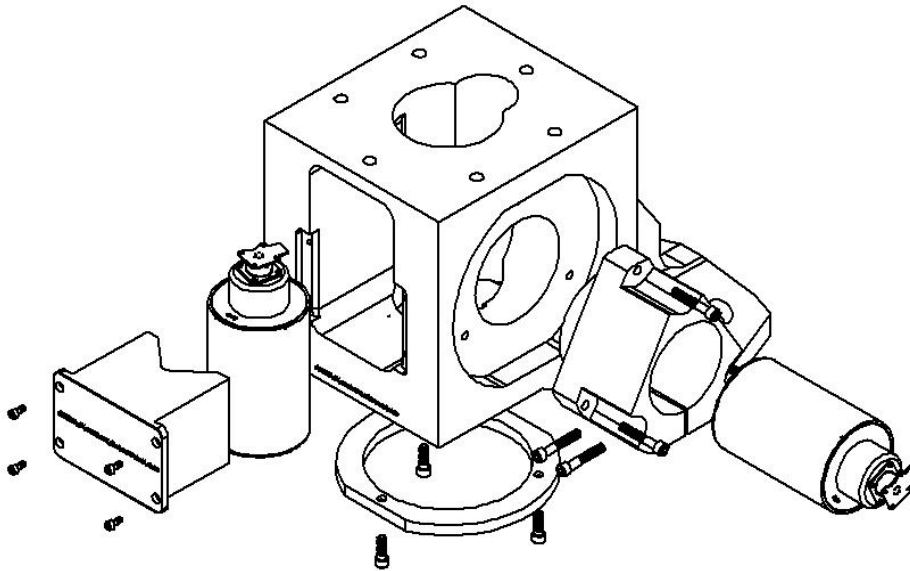

5. Mount the pier pre-amp box and the Kaman junction box to the blank-off plate (D020128) with cable connections facing down. Mount the blank off plate to the housing assembly and connect the geophone and position sensor cables.
6. Connect the position sensor breakout box between the pier pre-amp box and the rack connection using the 15 pin connectors. Attach a voltmeter to the breakout box.
7. Adjust the micrometer on the position sensor until you see +/- 8 volts. If this range is not attainable move the position switches. **Caution:** *Remove the flag (D020255).*
8. Attach the flexible hoses to supply and return ports on actuator and connect to the four-way valve.

**HEPI Assembly and Installation Procedures**

9. Attach the Front Side Caging Brace Assembly (D030322) to the sides of the housing as shown. Use (4) ½ - OD: 1.25" flat washers and (4) ½-13 x 1.00" Hex Head screw. Firmly hand-tighten.

10. Attach housing stiffeners (D020329) and (D020330) to the housing as shown below. Use (6) 3/8-16 x 1.00" Hex Head screws and (6) 3/8 flat washer for each stiffener leg. Torque to 30 ft-lbs.

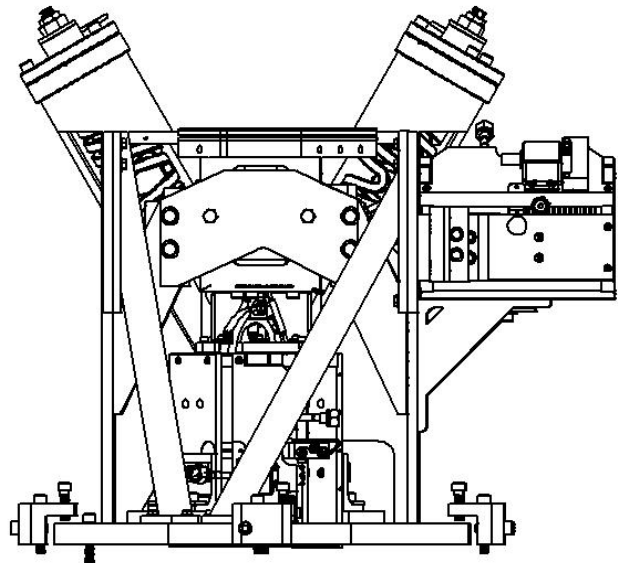
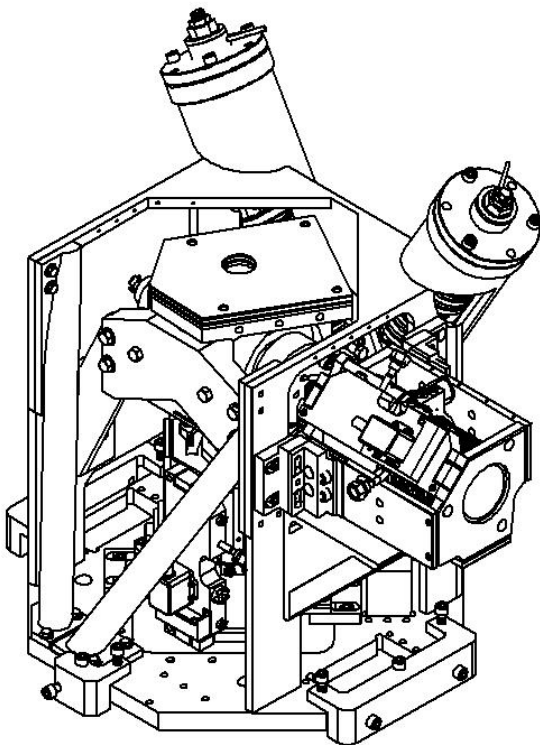
**Required Hardware**

(1) x Vertical L4-C
 (1) x Horizontal L4-C
 (1) x Vertical L4-C Hold-down
 (1) x Horizontal L4-C Clamp
 (1) x Front Side Caging Brace Ass'y
 (1) x Housing Stiffener - Long
 (1) x Housing Stiffener - Short

Required Fasteners

(4) x #8-32 x 0.375" SHCS
 (5) x ¼-20 x 1.50" SHCS
 (4) x ½-13 x 1.00" Hex H. Screw
 (4) x ½ OD: 1.125" flat washer
 (12) x 3/8-16 x 1.00" Hex H. Scr
 (12) x 3/8 flat washer

Reference drawing(s): D030690 HEPI General Assembly, D030326 EPI Crossbeam Attachment Assembly, D030322 EPI Caging Brace Assembly



HEPI Assembly and Installation Procedures

15. REMOVING AIR FROM ACTUATOR

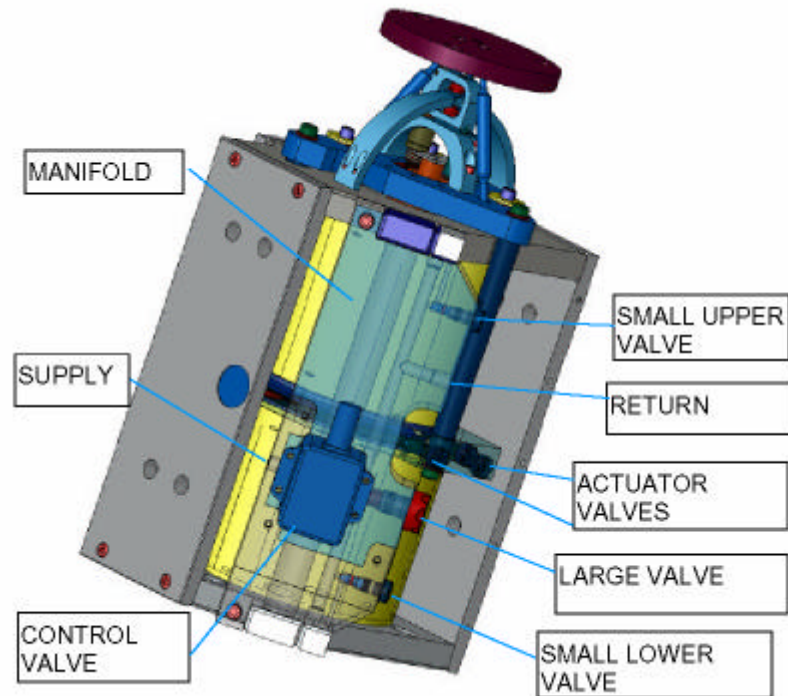

1. Verify that all hoses are connected with the feed line going to the manifold adjacent to the control valve and the return line out the opposite side of the manifold.
2. Close off valves at the pump station. Pressure leak test all connections at 15% over operating pressure (~90 psi) overnight.
3. Turn on the pump station. Open resistor bleeds until all air bubbles have been removed. Open valves to the actuators.
4. Bleed the vertical actuator of trapped gas.
 - a) Open the left and right valves located on the actuator plate 2 turns. Leave the center valve closed. These valves remove trapped air from the lower bellows and the resistor.
 - b) Open the upper valve located on the side of the manifold plate. This valve purges air from the upper bellows.
 - c) Close the lower valve located on the side of the manifold and the larger valve located in the center of the manifold. By closing the larger valve, you are diverting the fluid through the built in bleed passages.
 - d) Allow the actuator to remain in the bleed state for 24 to 36 hours with the pump running.
 - e) To place the actuator into run mode, close all small valves on the actuator plate and the side of the manifold plate. Open the large valve also on the side of the manifold 2 turns.
 - f) Replace all plugs over large and small valves.



LIGO

LASER INTERFEROMETER GRAVITATIONAL WAVE OBSERVATORY

INSTALLATION SPECIFICATION

E040011 -B- E

Drawing No Rev. Group

Sheet 21 Of 22

HEPI Assembly and Installation Procedures

5. Bleed the horizontal actuator of trapped gas.
 - g) Remove the horizontal actuator and position it so that the tripod is facing upward. Bleed this actuator using the same procedure described in step 4. The purpose of this step is to remove trapped air which could get lodged in the convolutions of the bellows.
 - h) Re-attach the horizontal actuator to the angle bracket (D020016) and Boot (D020004) per section 7.
 - i) Open all small valves located on the actuator plate and on the manifold 2 turns. Close the large valve located on the side of the manifold plate.
 - j) Allow the actuator to remain in the bleed state for 24 hours with the pump running.
 - k) To place the actuator into run mode, close all small valves on the actuator plate and the side of the manifold plate. Open the large valve also on the side of the manifold 2 turns.
 - l) Replace all plugs over large and small valves.



HEPI Assembly and Installation Procedures

APPENDIX – INSTALLATION OF PNEUMATIC BEARING

Install (4) pneumatic lift assemblies (D020375) on the housing as shown below. Add the manifold, gauge, and pneumatic tubing. Use (6) 3/8-16 x 1.50" SHC screws for each assembly.

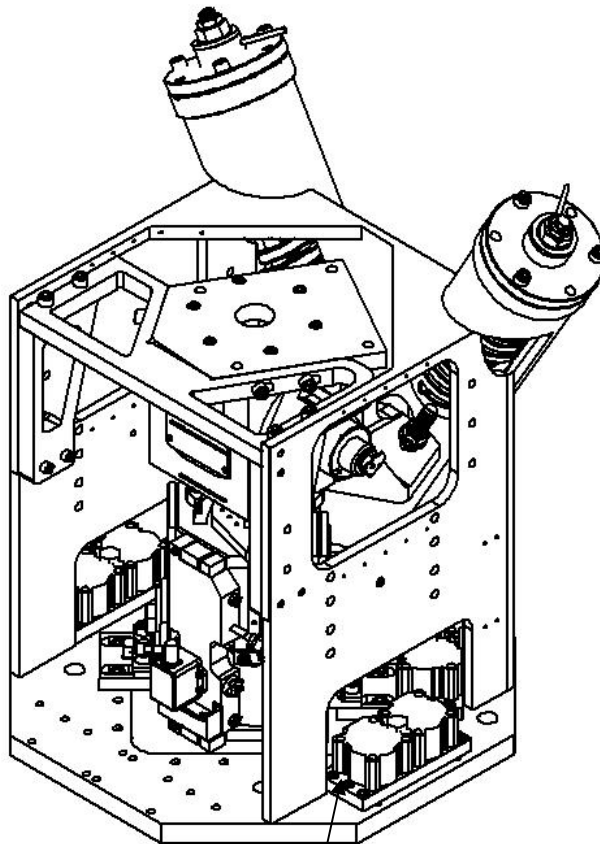

Install (4) pneumatic bearing assemblies onto the housing.