

1

2

3

4

NOTES: (UNLESS OTHERWISE SPECIFIED)

- 1 ALL ABRASIVE CUTTING TO BE DONE FROM NEAR SIDE.
- 2 GLASS TO BE COVERED BY VINYL MASK ON] NEAR SIDE PRIOR TO START OF MACHINING.
- 3 MAKE FROM #12 WELDERS FILTER GLASS (SCHOT) .12" THICK
- 4 AR COAT ONE SIDE OF GLASS PLATE R<0.5% FROM 600nm TO 1100nm.
- 5 ENGRAVE OR ETCH PART, WHERE NOTED, WITH DRAWING NUMBER FOLLOWED BY THREE DIGIT SERIAL NUMBER. SERIAL NUMBERS TO START AT 001 AND PROCEED IN A CONSECUTIVE MANNER TO A MAXIMUM OF 999, IN ORDER PRODUCED.
EXAMPLE: D990XXX-A-001

REV	DATE	DRAWN BY	CHECKED	DCC	DCN/DESCRIPTION
A	11-9-99	J. Romie			E990405/INITIAL RELEASE

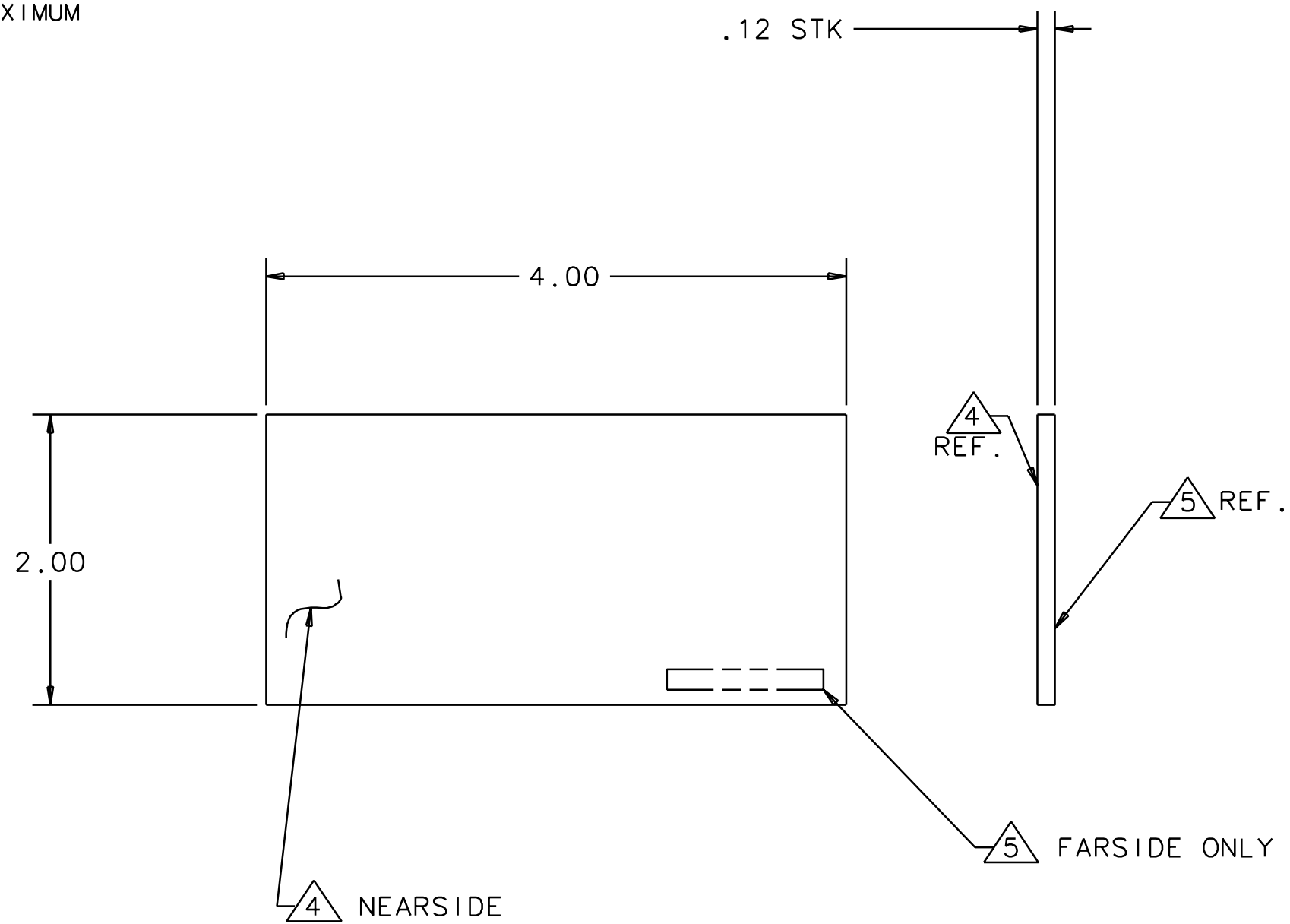

QTY REQD	FSCM NO	PART OR IDENTIFYING NO	NOMENCLATURE OR DESCRIPTION	MATERIAL SPECIFICATION	ITEM NO
PARTS LIST					
UNLESS OTHERWISE SPECIFIED DIMENSIONS ARE IN INCHES TOLERANCES ARE: FRACTIONS DECIMALS 0.XX = +.00 -.03			APPROVALS DRAWN J. Romie CHECKED	DATE 8/99	TITLE GLASS BEAM DUMP, 2 x 4
DO NOT SCALE DRAWING			MATERIAL 3		SIZE B
NEXT ASSEMBLY D990490			FINISH 1 2		DWG NO. D990487
FILE LOCATION /home/dcc/docs/D990487.pdf			SCALE 1/1		REV. A
				SHEET 1 OF 1	

1

2

3

4

A

B

C

D

A

B

C

D