

DETAIL 'A'
MOUNTING PLATE
24 REQ'D
4 1/2" X 6" X 1/2" THK CRS

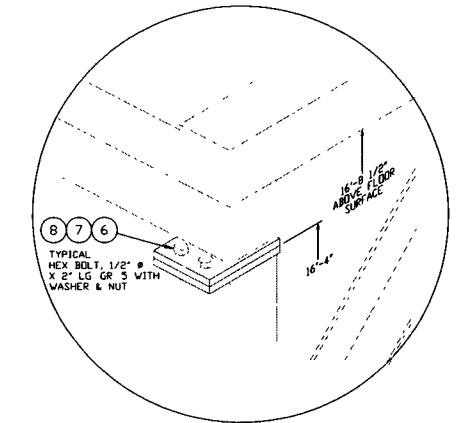

DETAIL 'C'
TYPICAL UPRIGHT MOUNTING

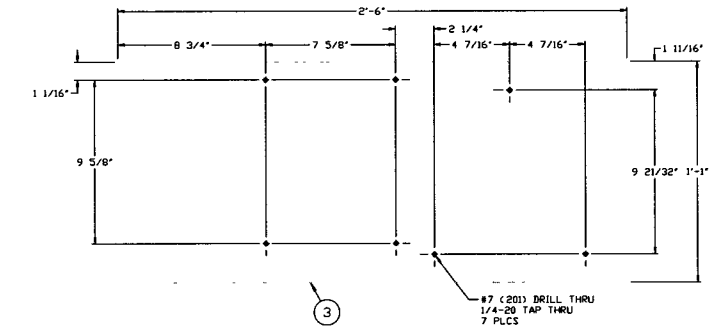

DETAIL 'B'
CONTROL MOUNTING PLATE
30\"/>

ELECTRONIC COPY

- NOTES:
 1) ASSEMBLE AROUND COMPLETED STATION ENCLOSURE PRIOR TO BOLTING UPRIGHTS TO TOP SECTION.
 2) PAINT WITH 2-PART WHITE EPDXY.

LIGO-D990326-00-V

DWG. NO.	DESCRIPTION	DWG. NO.	DESCRIPTION

DO NOT SCALE THIS DRAWING	ISSUED FOR FABRICATION	BAR	7/9/96	0204	
USED ON	REV	CHKD	DRWN	DATE	DESN

PROCESS SYSTEMS INTERNATIONAL, INC.
 20 MAULP DR. WESTBOROUGH, MASSACHUSETTS 01581 USA

WASHING STATION ENCLOSURE
 STRUCTURE WELDMENT
 LIGO VACUUM EQUIPMENT

CAD FILE: V0494803
 SIZE: D
 DWG. NO.: V049-4-803
 REV: 0

SCALE: 1/32
 SHEET: 1 OF 1

PROPERTY AND CONFIDENTIAL

Aug. 06, 1996 - 095942