

NOTES: (UNLESS OTHERWISE SPECIFIED)

- CUTTING FLUIDS TO BE WATER SOLUBLE AND FREE OF SULFUR, CHLORINE, & SILICONE.
- STEEL STAMP OR ENGRAVE THE DRAWING PART NUMBER ON NOTED FACE OF PART FOLLOWED BY 'S/N', THEN A THREE DIGIT SERIAL NUMBER. SERIAL NUMBERS TO START AT 001 FOR FIRST PART AND PROCEED IN A CONSECUTIVE MANNER TO A MAXIMUM OF 999, FOR EACH SUCCEEDING PART PRODUCED. USE .013 HIGH CHARACTERS. EXAMPLE: D990038-A S/N 001

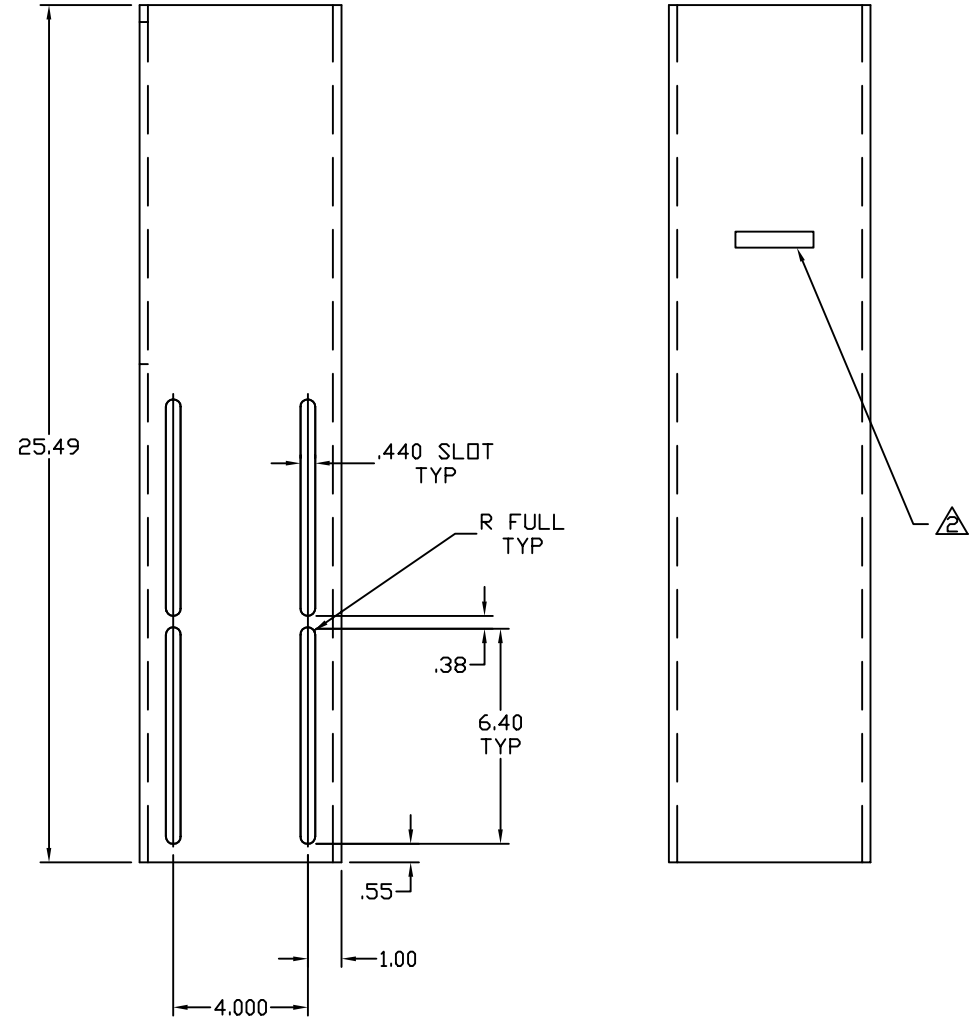
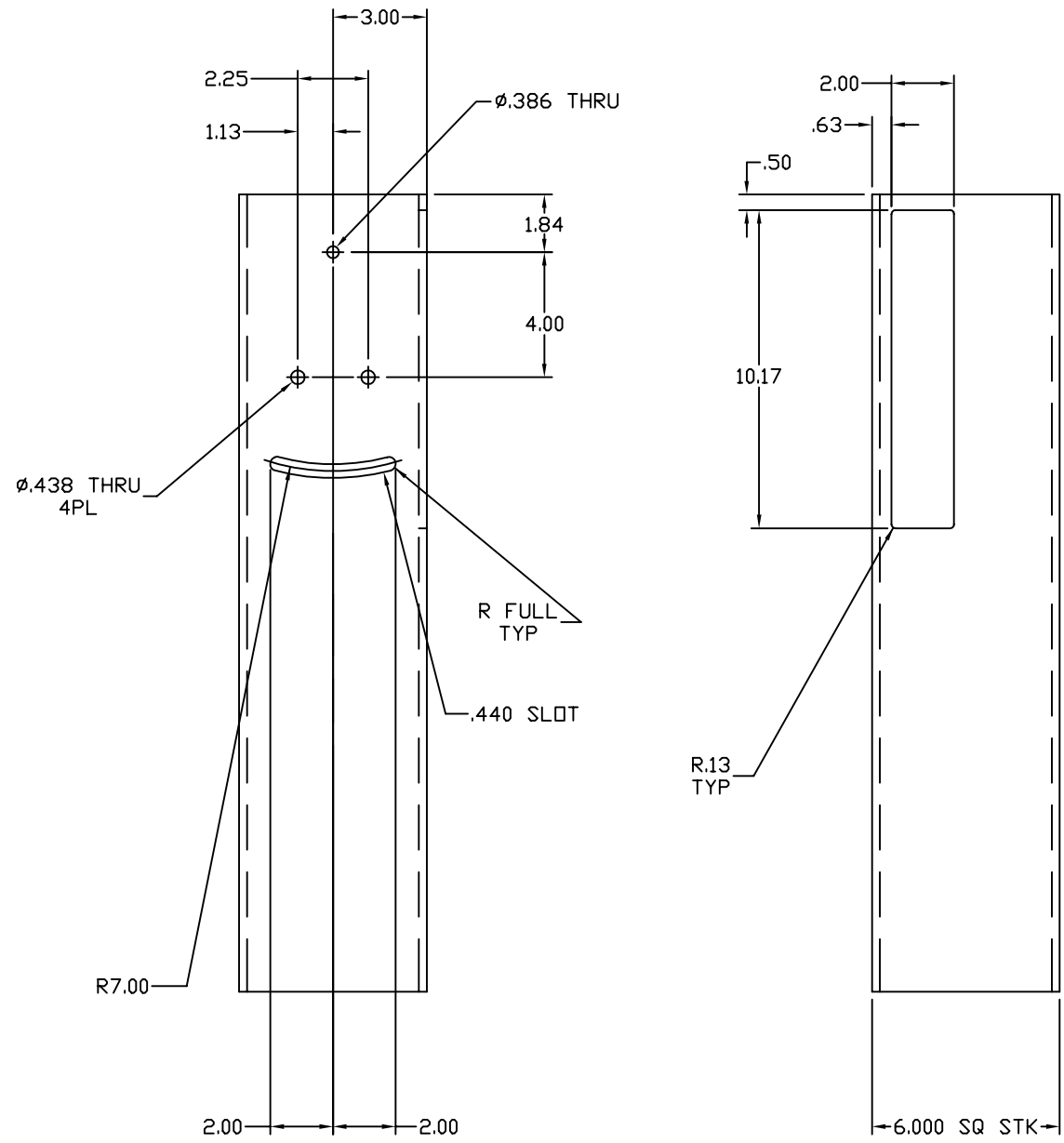

		UNLESS OTHERWISE SPECIFIED DIMENSIONS ARE IN INCHES							LIGO CALIFORNIA INSTITUTE OF TECHNOLOGY MASSACHUSETTS INSTITUTE OF TECHNOLOGY		
		TOLERANCES: FRACTIONAL ± ANGULAR ± ANGULAR MACH ± BEND ± TWO PLACE DECIMAL ±.01		THREE PLACE DECIMAL ±.005 FINISHED SURFACE RMS BREAK CORNERS IN: OUT: .005-.010 REMOVE ALL BURRS		C DCN E990244		Conley		6-7-99	
		MATERIAL: 6061-T6 ALU TUBING 6" SQ, 1/4" WALL		HEAT TREAT:		B DCN E990210		Conley		5-25-99	
DWG. NO.		DESCRIPTION		FINISH:		A DCN E990210		Conley		5-18-99	
REFERENCE DRAWINGS		USED ON:		NEXT ASS'Y: D990403		REV		DESCRIPTION		SCALE	
								APPR'D		CHECK	
								DRWN		DATE	
								SCALE		SHEET	
								NTS		1 OF 1	
								ISSUE DESCRIPTION			

CAVITY BEAM DUMP HOUSING TUBE,  
BSC4, 2KITMXAR1, 2KITMYAR1, 2KRMHR3  
BSC2, 4KITMXAR1, 4KITMYAR1

CAD FILE: D990252-C.dwg  
SIZE: B  
DWG. NO.: D990252-C