

NOTES: (UNLESS OTHERWISE SPECIFIED)

- CUTTING FLUIDS TO BE WATER SOLUBLE AND FREE OF SULFUR, CHLORINE, & SILICONE.
- STEEL STAMP OR ENGRAVE THE DRAWING PART NUMBER ON NOTED FACE OF PART FOLLOWED BY "S/N", THEN A THREE DIGIT SERIAL NUMBER. SERIAL NUMBERS TO START AT 001 FOR FIRST PART AND PROCEED IN A CONSECUTIVE MANNER TO A MAXIMUM OF 999, FOR EACH SUCCEEDING PART PRODUCED. USE .013 HIGH CHARACTERS.
EXAMPLE: D990038-A S/N 001

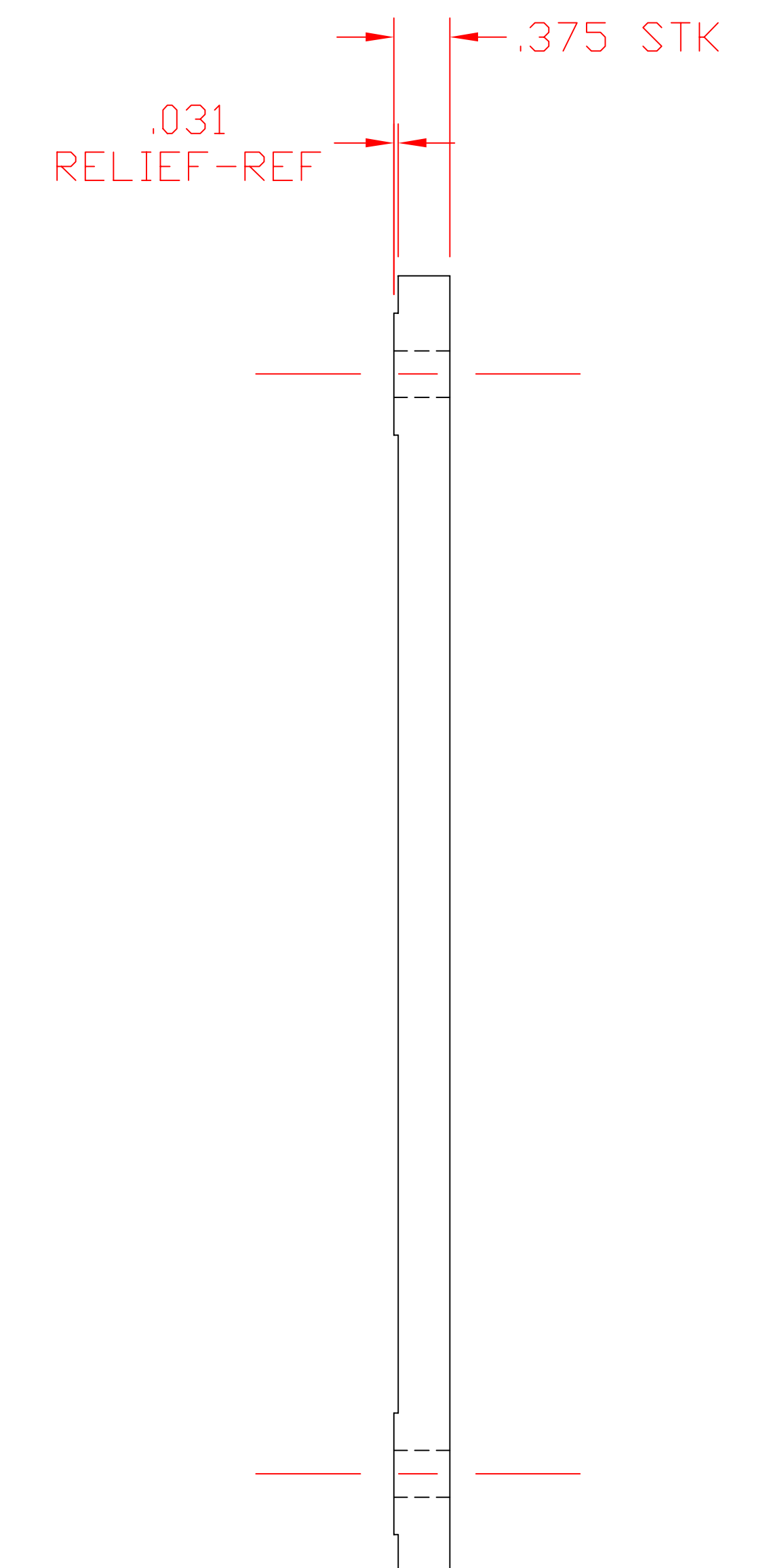
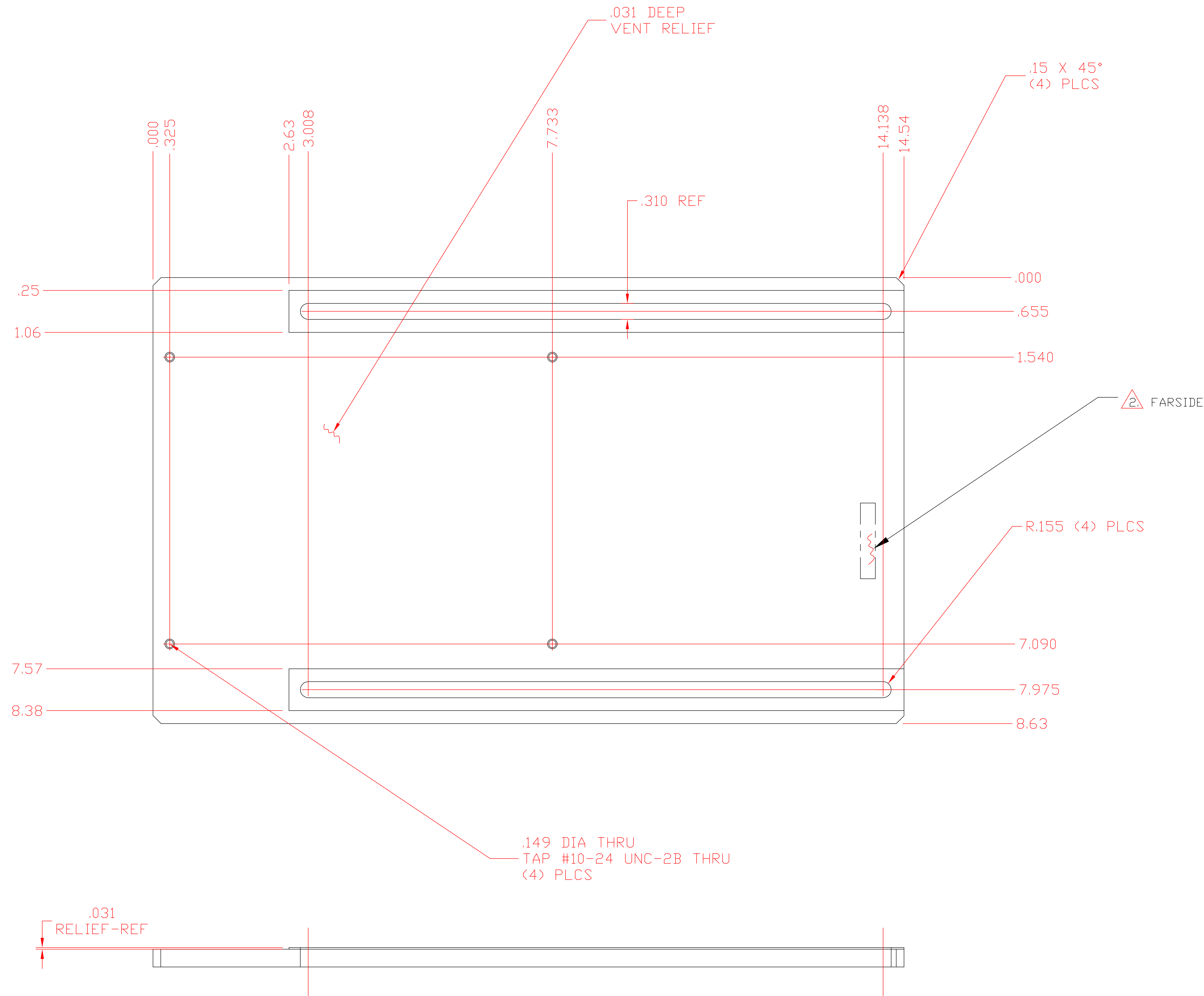

DWG. NO.	DESCRIPTION
	REFERENCE DRAWINGS

UNLESS OTHERWISE SPECIFIED DIMENSIONS ARE IN FEET (cm)		
TOLERANCES:	THREE PLACE DECIMAL ± .003	
FRACTIONAL ± 1/64	FINISHED SURFACE RMS	
ANGULAR ± 1/2°	BREAK CORNERS .005 - .020	
ANGULAR MACH ± BEND ±	REMOVE ALL BURRS	
TWO PLACE DECIMAL ± .01		
MATERIAL: .375 THICK TYPE 6061-T6 ALUMINUM ALLDY	HEAT TREAT:	FINISH:
USED ON:	NEXT ASS'Y: D990239	

A	RELEASE	E990210	-	-	-	KABDT	5-13-99
REV	DESCRIPTION	DCN NUMBER	-	APPR'D	CHECK	DRWN	DATE
ISSUE DESCRIPTION							

LIGO CALIFORNIA INSTITUTE OF TECHNOLOGY MASSACHUSETTS INSTITUTE OF TECHNOLOGY			
PLATE BEAM DUMP 14-5 BACKPLATE			
CAD FILE	SIZE	DWG. NO.	
PL_BDMP_14-5PL.dwg	C	D990241-A	
SCALE	NTS	SHEET	1 OF 1