

6 5 4 3 2 1

NOTES: (UNLESS OTHERWISE SPECIFIED)

~~Liquid contaminants/Machining Lubricants~~
 Liquids containing hydrocarbons or other contaminants, other than the machining fluids specified herein, shall not be allowed to come into contact with suspension material at any time. All machining fluids shall be water soluble and free of sulfur, chlorine and silicone; such as Cincinnati Milacron's Cimtech 410 (stainless steel).

Identification_Serial Number
 A serial number shall be etched, or scribed on the part see note drawing note.
Serial Number Format
 The Serial number shall be of the format:
 D99xxxx-x-001

Example: D990021-A-001
 The drawing number, The revision number, The sequential part number

Grind Ends Flat
 Bag and Tag W/ Part No.

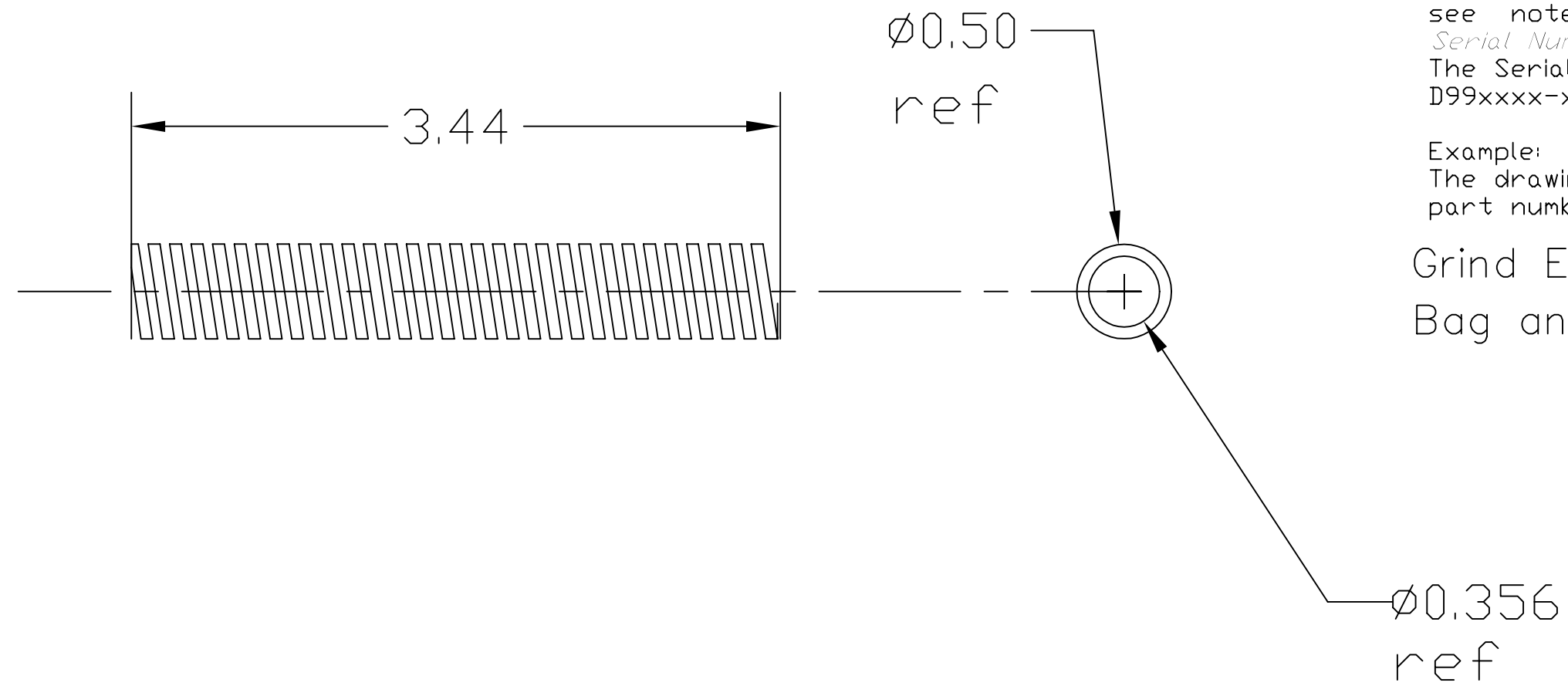

Qty. Make 2 Per Assembly _16 Total

4	1	-	-	-
3	2	-	-	-
2	1	-	-	-
1	1	-	-	-
REF.	QTY.	PART or DRWG No.	NOMENCLATURE or DESCRIPTION	MATERIAL

PARTS and MATERIAL LIST

UNLESS OTHERWISE SPECIFIED DIMENSIONS ARE IN INCHES								LIGO CALIFORNIA INSTITUTE OF TECHNOLOGY MASSACHUSETTS INSTITUTE OF TECHNOLOGY			
TOLERANCES:		FINISHED SURFACE RMS 63								TITLE PICK OFF MIRROR Spring	
FRACTIONAL ± 1/32		BREAK CORNERS and EDGES								KCNM 11/11/99	
THREE PLACE DECIMAL ± .005		ANGULARMACH ± BEND ±--								KCNM 6/28/99	
TWO PLACE DECIMAL ± .01		REMOVE ALL BURRS								KCNM 4/17/99	
ANGULAR ± 1 deg.										CAD FILE D990115-C	
MATERIAL: McMaster 9663K28		HEAT TREAT: none		FINISH: none						SIZE DWG. NO. B D990115-C	
USED ON: XXX		NEXT ASS'Y: XXX								SCALE FULL SHEET	
DWG. NO. REFERENCE DRAWINGS						ISSUE DESCRIPTION					

6 5 4 3 2 1