

NOTES: (UNLESS OTHERWISE SPECIFIED)

*Liquid contaminants/Machining Lubricants*  
 Liquids containing hydrocarbons or other contaminants, other than the machining fluids specified herein, shall not be allowed to come into contact with suspension material at any time. All machining fluids shall be water soluble and free of sulfur, chlorine and silicone; such as Cincinnati Milacron's Cimtech 410 (stainless steel).

*Identification Serial Number*  
 A serial number shall be etched, or scribed on the part see note drawing note.

*Serial Number Format*  
 The Serial number shall be of the format:  
 D99xxxx-x-001

Example: D990021-A-001  
 The drawing number, The revision number, The sequential part number

Bag and Tag W/ Part No.

0.44  
Stock  
ref.

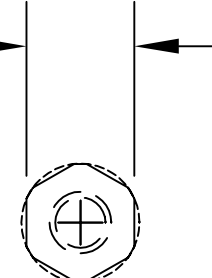

∅0.479  
Head Diameter

3.50  
Stock  
ref.

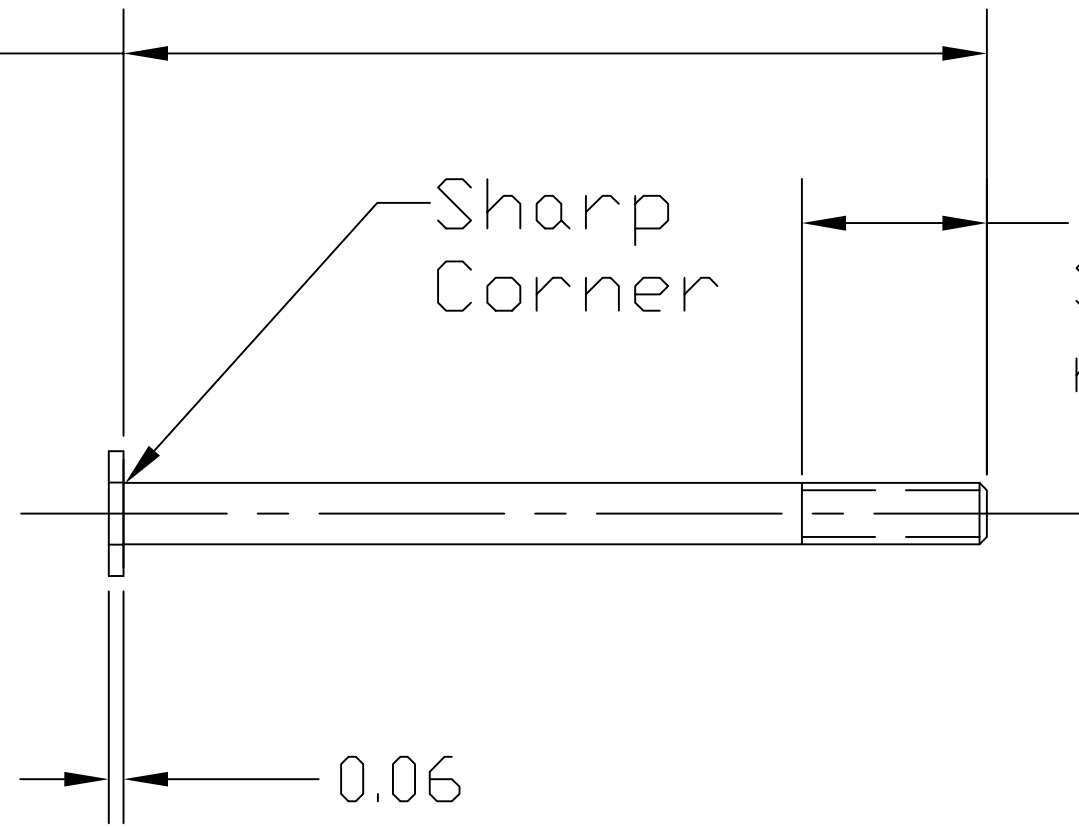

0.75  
Stock  
ref.

0.06

Qty. Make 2 Per Assembly

4	1	-	-	-
3	2	-	-	-
2	1	-	-	-
1	1	-	-	-
REF.	QTY.	PART or DRWG No.	NOMENCLATURE or DESCRIPTION	MATERIAL

UNLESS OTHERWISE SPECIFIED DIMENSIONS ARE IN INCHES									
TOLERANCES:					FINISHED SURFACE RMS 63				
FRACTIONAL ± 1/32					BREAK CORNERS and EDGES				
THREE PLACE DECIMAL ± .005					ANGULAR MACH ± BEND ±---				
TWO PLACE DECIMAL ± .01					REMOVE ALL BURRS				
ANGULAR ± 1 deg.									
MATERIAL:		HEAT TREAT:		FINISH:		DATE:		SCALE:	
1/4-28 x 3.5 Lg. S Stl. Hex Hd. Scr.		none		none		4/15/99		FULL	
DWG. NO. REFERENCE DRAWINGS		USED ON: XXX		NEXT ASS'Y: XXX		ISSUE DESCRIPTION		SHEET	
6		5		4		3		1	

**LIGO** CALIFORNIA INSTITUTE OF TECHNOLOGY  
 MASSACHUSETTS INSTITUTE OF TECHNOLOGY  
 TITLE TENSION SCREW  
 CAD FILE D990113-B  
 SIZE DWG. NO. B D990113-B  
 SHEET