

NOTES: UNLESS OTHERWISE SPECIFIED
 1. XXXXXXXXXXXXXXXXXXXXXXXXXXXXXXXXXXXXXXX
 2. XXXXXXXXXXXXXXXXXXXXXXXXXXXXXXXXXXXXXXX

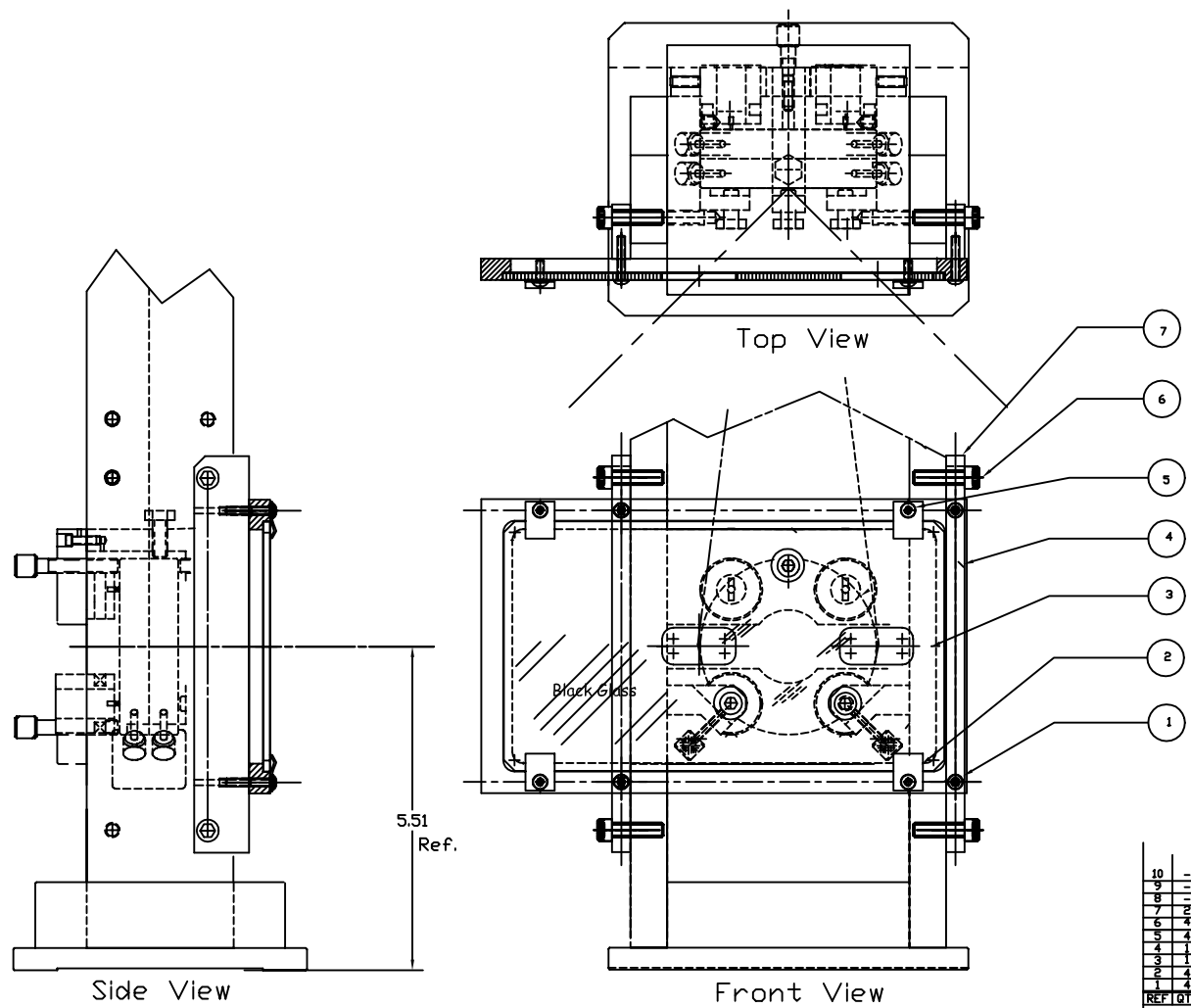

REF	QTY	PART or DRWG No.	DESCRIPTION	MATERIAL
10	-	-	-	-
9	-	-	-	-
8	-	-	-	-
7	2	0900689	Bracket	-
6	4	-	1/4-20 x 1.0 lg. SHCS	300/18-0 Stainless Steel
5	4	-	6-32 x .38 lg. Socket Button Hd.	300/18-0 Stainless Steel
4	1	0900688	Frame	-
3	1	0900686	Black Glass	-
2	4	0900685	Clamp	-
1	4	-	6-32 x .75 lg. Socket Button Hd.	300/18-0 Stainless Steel

UNLESS OTHERWISE SPECIFIED DIMENSIONS ARE IN INCHES		TOLERANCES: FRACTIONAL ± --- ANGULAR ± ANGULAR MACH ± -- BEND ± -- TVD PLACE DECIMAL ± .02		THREE PLACE DECIMAL ± .010 FINISHED SURFACE RING 63 BREAK CORNERS IN - OUT - REMOVE ALL BURRS		MATERIAL: None		HEAT TREAT: None		FINISH: None		NEXT ASSY: XXX		REV		DESCRIPTION		ISSUE DESCRIPTION		APPR'D		CHECK		DRWN		DATE		SCALE		FULL		DRAWING NO.		LIGO-D980689-A		SHEET		1 of 1									
XXX		XXX		None		None		None		None		None		A		For Fabrication		LMB		kern		12-7-99		00		PRE-RELEASE		LMB		-		-		kern		12-17-98		EAM FILE		D		LIGO-D980689-A		1		1 of 1	
DWG. NDL		DESCRIPTION		MATERIAL		HEAT TREAT		FINISH		REV		DESCRIPTION		ISSUE DESCRIPTION		APPR'D		CHECK		DRWN		DATE		SCALE		FULL		DRAWING NO.		LIGO-D980689-A		SHEET		1 of 1													
7		REFERENCE DRAWINGS		6		USED ON XXX		5		NEXT ASSY: XXX		4		3		2		1																													

LIGO CALIFORNIA INSTITUTE OF TECHNOLOGY
 MASSACHUSETTS INSTITUTE OF TECHNOLOGY
 Mode Cleaner Baffle
 Assembly