

NOTES: (UNLESS OTHERWISE SPECIFIED)

*Liquid contaminants/Machining Lubricants*  
Liquids containing hydrocarbons or other contaminants, other than the machining fluids specified herein, shall not be allowed to come into contact with suspension material at any time. All machining fluids shall be water soluble and free of sulfur, chlorine and silicone; such as Cincinnati Milacron's Cimtech 410 (stainless steel).

*Identification Serial Number*  
A serial number shall be etched, or scribed on the part see note drawing note.

*Serial Number Format*  
The Serial number shall be of the format: D99xxxx-x-001

Example: D990021-A-001  
The drawing number, The revision number, The sequential part number

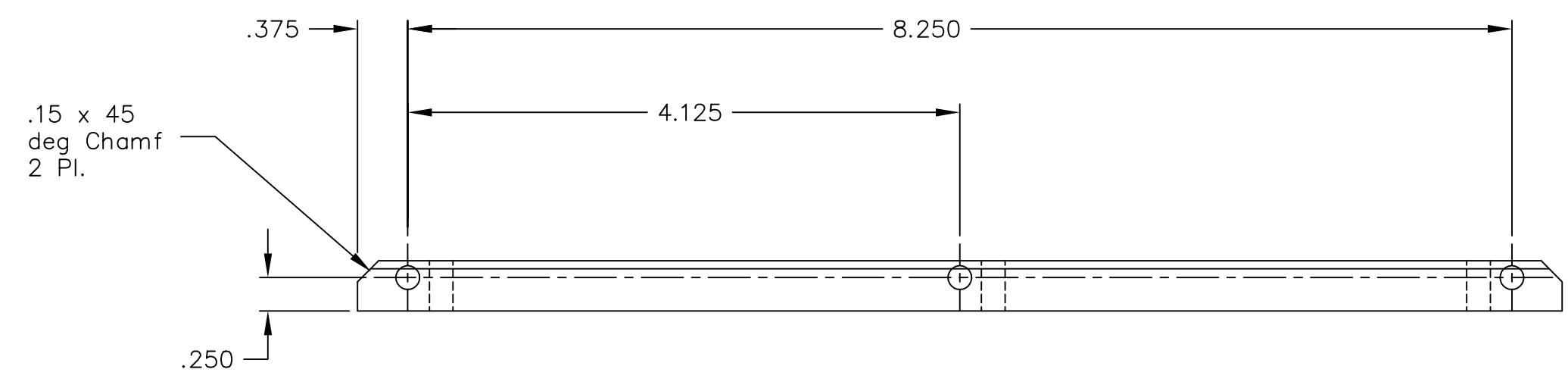
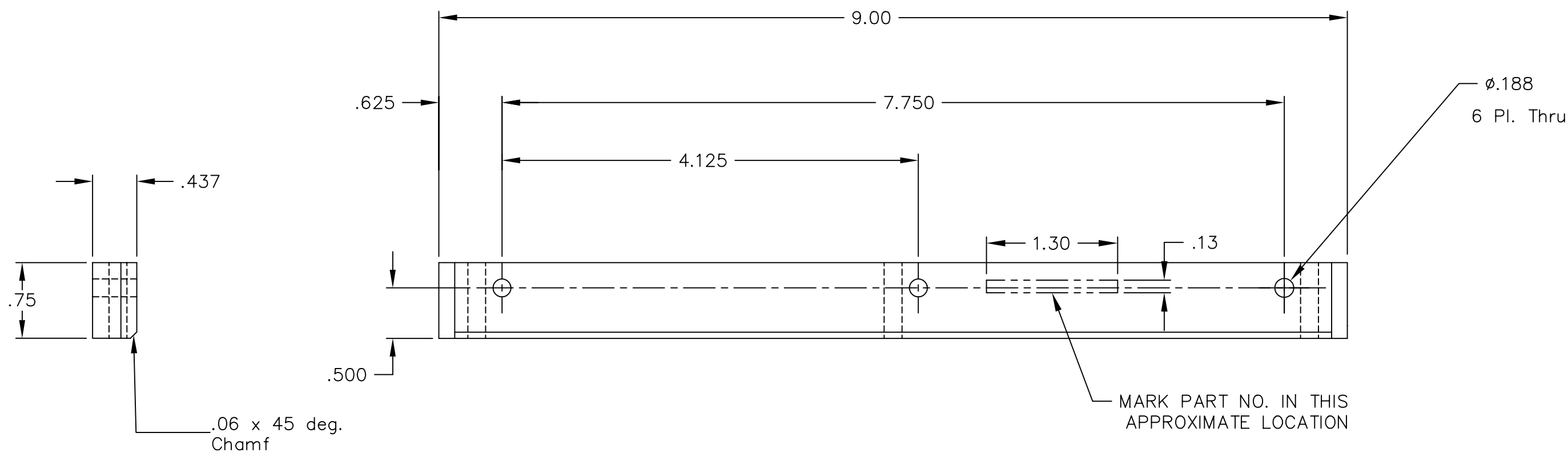

ref. make 2 per assembly

REF	QTY	PART or DRWG No.	DESCRIPTION	MATERIAL
PARTS and MATERIAL LIST				
<b>LIGO</b> CALIFORNIA INSTITUTE OF TECHNOLOGY MASSACHUSETTS INSTITUTE OF TECHNOLOGY				
BAR, TUBE AND BOX, SHORT				
		kenn		6-8-99
XXX		CHAPUT		11-3-98
CAD FILE	SIZE	DWG. NO.		
D980594-B	C	D980594-B		
SCALE				SHEET
1 : 1				1 OF 1

TOLERANCES:		UNLESS OTHERWISE SPECIFIED	
DIMENSIONS ARE IN FEET [cm]			
FRACTIONAL ±	THREE PLACE DECIMAL ±		
ANGULAR ±	FINISHED SURFACE RMS		
ANGULAR MACH ± BEND ±	BREAK CORNERS IN/OUT		
TWO PLACE DECIMAL ±	REMOVE ALL BURRS		
MATERIAL:	HEAT TREAT:	FINISH:	
6061 T-6 ALUM.	/	/	
USED ON: XXX	NEXT ASS'Y: XXX		