

MARK PART NO. IN THIS APPROXIMATE LOCATION

NOTES: (UNLESS OTHERWISE SPECIFIED)
 Liquid contaminants/Machining Lubricants
 Liquids containing hydrocarbons or other contaminants, other than the machining fluids specified herein, shall not be allowed to come into contact with suspension material at any time. All machining fluids shall be water soluble and free of sulfur, chlorine and silicone; such as Cincinnati Milacron's Cimtech 410 (stainless steel).

Identification_Serial Number
 A serial number shall be etched, or scribed on the part see note drawing note.
 Serial Number Format
 The Serial number shall be of the format: D99xxxx-x-001

Example: D990021-A-001
 The drawing number, The revision number, The sequential part number

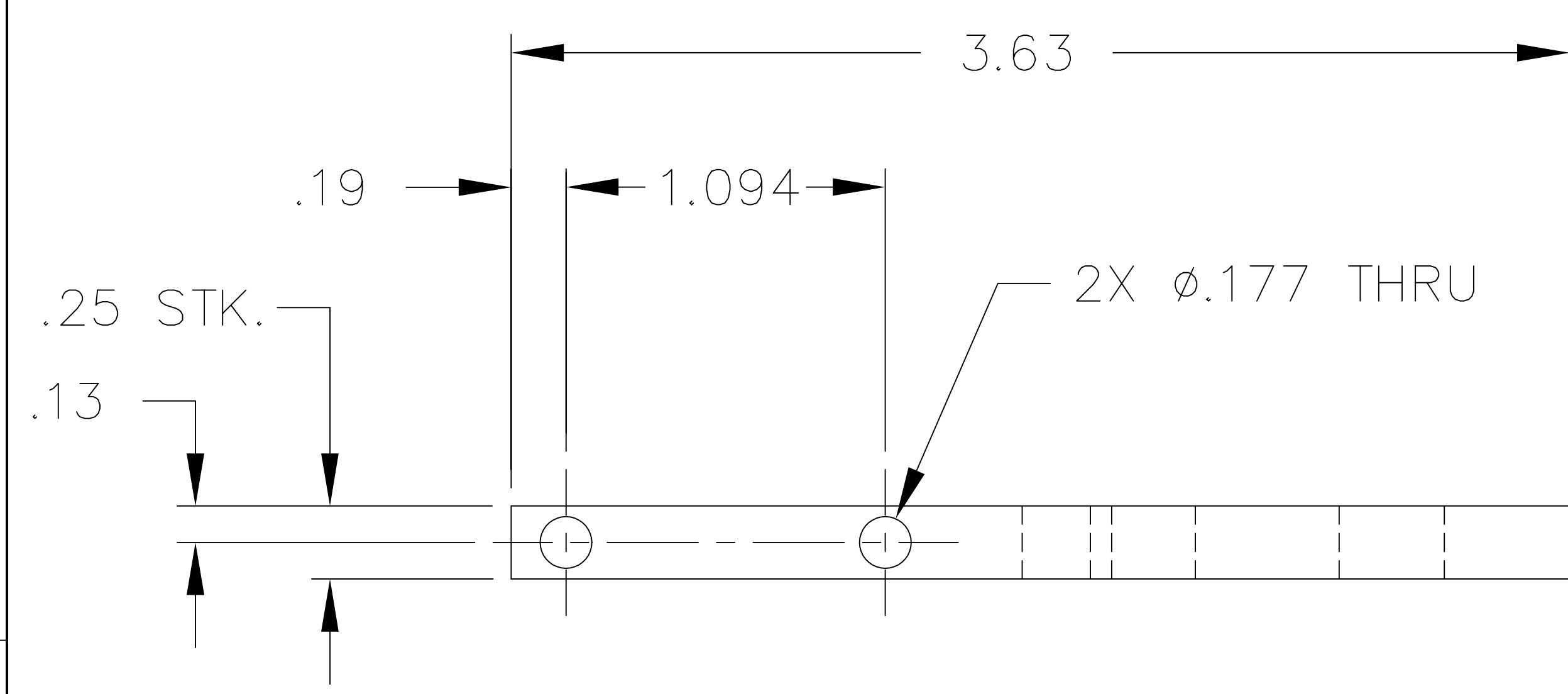

ref. make 2 per assembly

REF.	QTY.	PART or DRWG No.	NOMENCLATURE or DESCRIPTION	MATERIAL
------	------	------------------	-----------------------------	----------

PARTS and MATERIAL LIST

UNLESS OTHERWISE SPECIFIED DIMENSIONS ARE IN INCHES			
TOLERANCES: FRACTIONAL ± 1/16 ANGULAR ± .25° ANGULAR MACH ± BEND ± TWO PLACE DECIMAL ± .01	THREE PLACE DECIMAL ± .005 FINISHED SURFACE RMS 63 BREAK CORNERS IN: .015 OUT: .015 REMOVE ALL BURRS		
MATERIAL: 6061 T-6 ALUM.	HEAT TREAT: /	FINISH: /	
USED ON: XXX	NEXT ASS'Y: XXX		

A	FOR FABRICATION	LIGO-E000525-00-D	kenm	6-8-99
00	PRE-RELEASE	-	CHAPUT	11-4-98
REV	DESCRIPTION	DCN NUMBER	APPR'D	CHECK DRWN DATE

LIGO CALIFORNIA INSTITUTE OF TECHNOLOGY MASSACHUSETTS INSTITUTE OF TECHNOLOGY	
BRACKET, ALIGNMENT TELESCOPE	
CAD FILE: D980589-A	SIZE/DWG. NO. B D980589-A
SCALE: 1:1	SHEET: 1 OF 1