

NOTES: (UNLESS OTHERWISE SPECIFIED)

Liquid contaminants/Machining Lubricants
 Liquids containing hydrocarbons or other contaminants, other than the machining fluids specified herein, shall not be allowed to come into contact with suspension material at any time. All machining fluids shall be water soluble and free of sulfur, chlorine and silicone; such as Cincinnati Milacron's Cimtech 410 (stainless steel).

Identification Serial Number
 A serial number shall be etched, or scribed on the part see note drawing note.

Serial Number Format
 The Serial number shall be of the format: D99xxxx-x-001

Example: D990021-A-001
 The drawing number, The revision number, The sequential part number

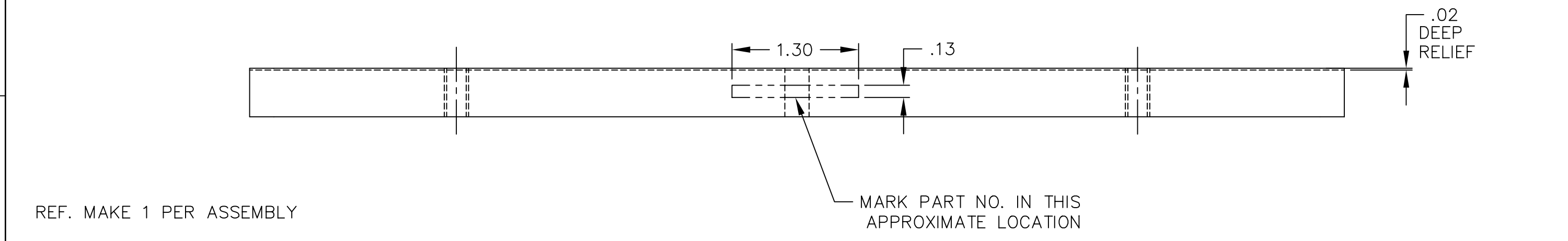
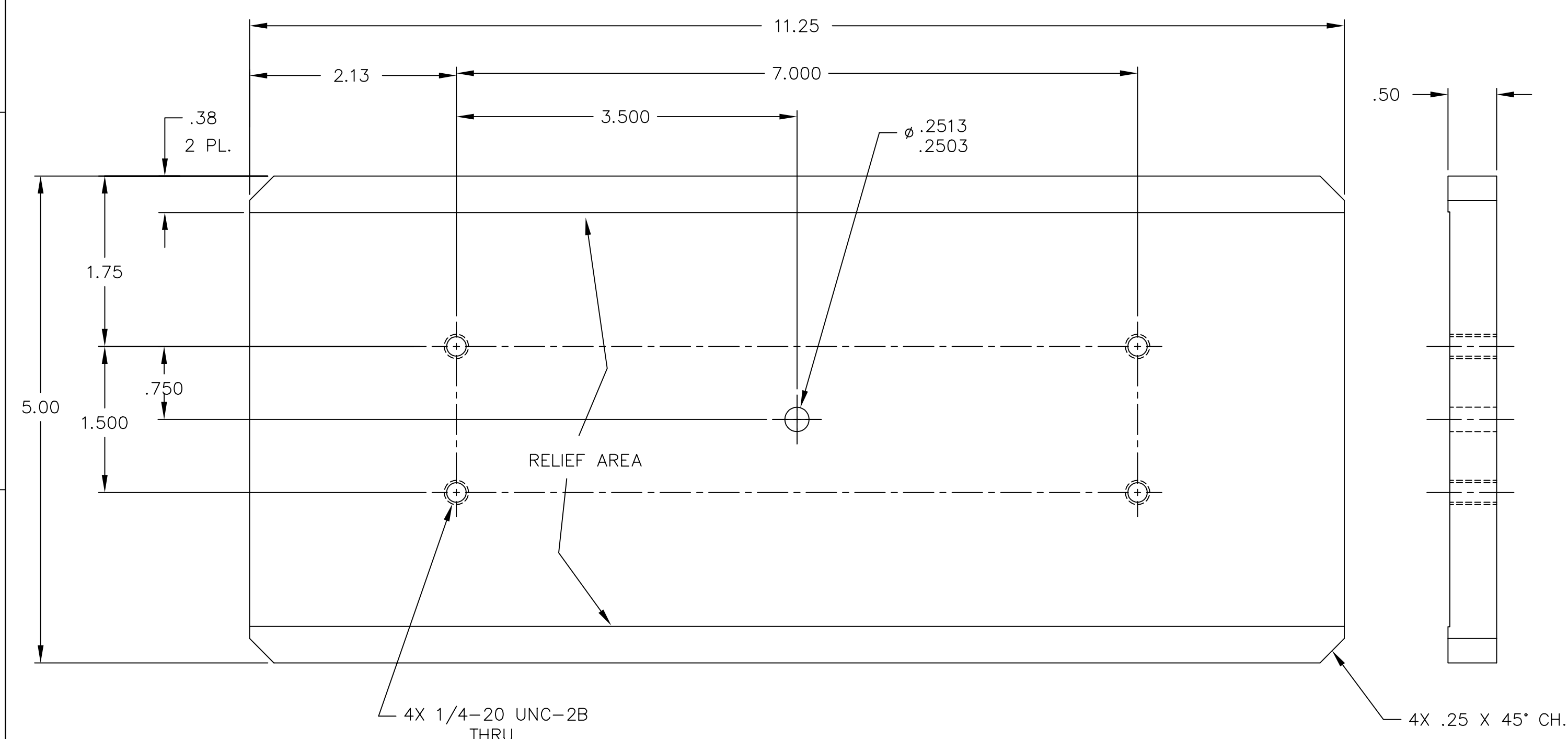

REF. MAKE 1 PER ASSEMBLY

| REF | | QTY | | PART or DRWG No. | | DESCRIPTION | | | | MATERIAL | |
|---|--|-----|--|------------------|--|-------------|--|--|------------|----------|--------|
| PARTS and MATERIAL LIST | | | | | | | | | | | |
| LIGO CALIFORNIA INSTITUTE OF TECHNOLOGY MASSACHUSETTS INSTITUTE OF TECHNOLOGY | | | | | | | | | | | |
| PLATE, BASE, REAR SUPPORT | | | | | | | | | | | |
| C | | | | | | | | | kenm | 8-8-99 | |
| B | | | | | | | | | kenm | 6-8-99 | |
| 00 | | | | | | | | | CHAPUT | 11-3-98 | |
| REV | | | | | | | | | DCN NUMBER | APPR'D | CHECK |
| | | | | | | | | | DRWN | DATE | |
| ISSUE DESCRIPTION | | | | | | | | | | SCALE | 1 : 1 |
| | | | | | | | | | | SHEET | 1 OF 1 |

UNLESS OTHERWISE SPECIFIED
 DIMENSIONS ARE IN FEET (cm)

TOLERANCES:
 FRACTIONAL ± 1/16
 ANGULAR ± .25°
 ANGULAR MACH - BEND -
 TWO PLACE DECIMAL ± .01

THREE PLACE DECIMAL ± .005
 FINISHED SURFACE RMS 63
 BREAK CORNERS IN: .015 OUT: .015
 REMOVE ALL BURRS

MATERIAL: ALUMINUM TOOLING PLATE
 HEAT TREAT: /
 FINISH: /

USED ON: XXX
 NEXT ASS'Y: XXX

D
C
B
A

D
C
B
A

6 5 4 3 2 1