

NOTES: (UNLESS OTHERWISE SPECIFIED)

~~ALL CONTAMINANTS/MACHINING~~ lubricants
Liquids containing hydrocarbons or other
contaminants, other than the machining
fluids specified herein, shall not be
allowed to come into contact with
suspension material at any time. All
machining fluids shall be water soluble and
free of sulfur, chlorine and silicone; such
as Cincinnati Milacron's Clintech 410
(stainless steel).

Identification Serial Number
A serial number shall be etched, or
scribed on the part see note drawing
note.

Serial Number Format
The Serial number shall be of the format:
D99xxx-x-00

Example: D990021-A-001
The drawing number, The revision number,
The sequential part number

ALL .37" SIDES TO BE SQUARE ON LONG
AXIS W/IN .008 TIR

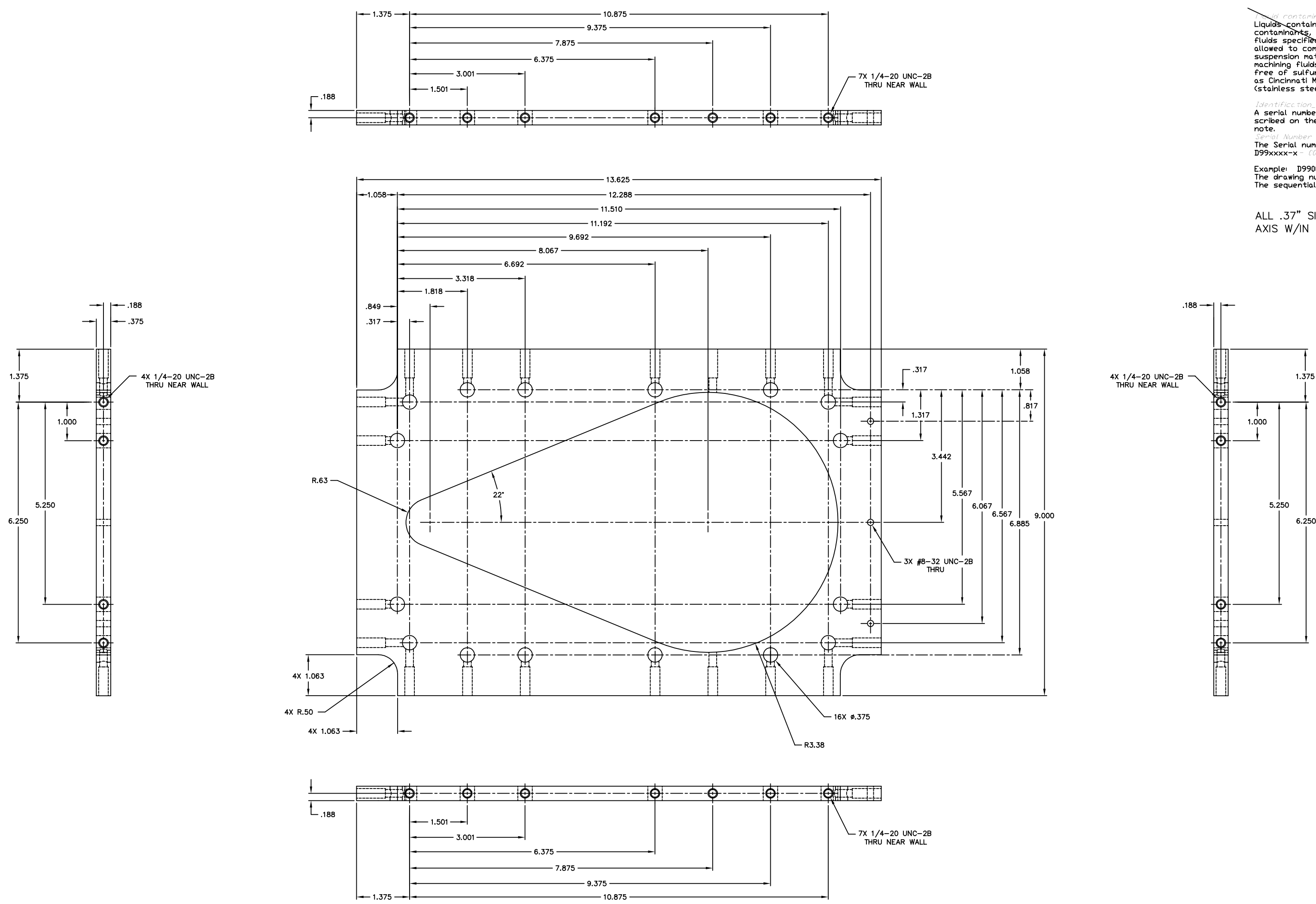

REF. MAKE 4 PER ASSEMBLY

REF	QTY	PART or DRWG No.	DESCRIPTION	MATERIAL
			PARTS and MATERIAL LIST	
				LIGO CALIFORNIA INSTITUTE OF TECHNOLOGY MASSACHUSETTS INSTITUTE OF TECHNOLOGY
				BULKHEAD GUSSET
			ADDED NOTE .37 SIDES SQ. W/IN .008	kenm 8-8-99
			FOR FABRICATION	kenm 6-8-99
			PRE-RELEASE	CHAPUT 11-3-98
			DCN NUMBER	APPR'D CHECK DRWN DATE
			ISSUE DESCRIPTION	SCALE FULL SHEET 1 OF 1

UNLESS OTHERWISE SPECIFIED
DIMENSIONS ARE IN INCHES

TOLERANCES:
FRACTIONAL ± 1/16
ANGULAR ± .25°
ANGULAR MATCH ± BEND ±
TWO PLACE DECIMAL ± .01

THREE PLACE DECIMAL ± .005
FINISHED SURFACE RMS 63
BREAK CORNERS IN .015 DUT .015
REMOVE ALL BURRS

MATERIAL: ALUMINUM TOOLING PLATE
HEAT TREAT: /
FINISH: /

USED ON: XXX
NEXT ASS'Y: XXX

DWG. NO.	DESCRIPTION	REV	DESCRIPTION
	REFERENCE DRAWINGS		