

7 6 5 4 3 2 1

NOTES: (UNLESS OTHERWISE SPECIFIED)

Liquid contaminants/Machining Lubricants
 Liquids containing hydrocarbons or other contaminants, other than the machining fluids specified herein, shall not be allowed to come into contact with suspension material at any time. All machining fluids shall be water soluble and free of sulfur, chlorine and silicone; such as Cincinnati Milacron's Cimtech 410 (stainless steel).

Identification Serial Number
 A serial number shall be etched, or scribed on the part see note drawing note.

Serial Number Format
 The Serial number shall be of the format: D99xxxx-x-001

Example: D990021-A-001
 The drawing number, The revision number, The sequential part number

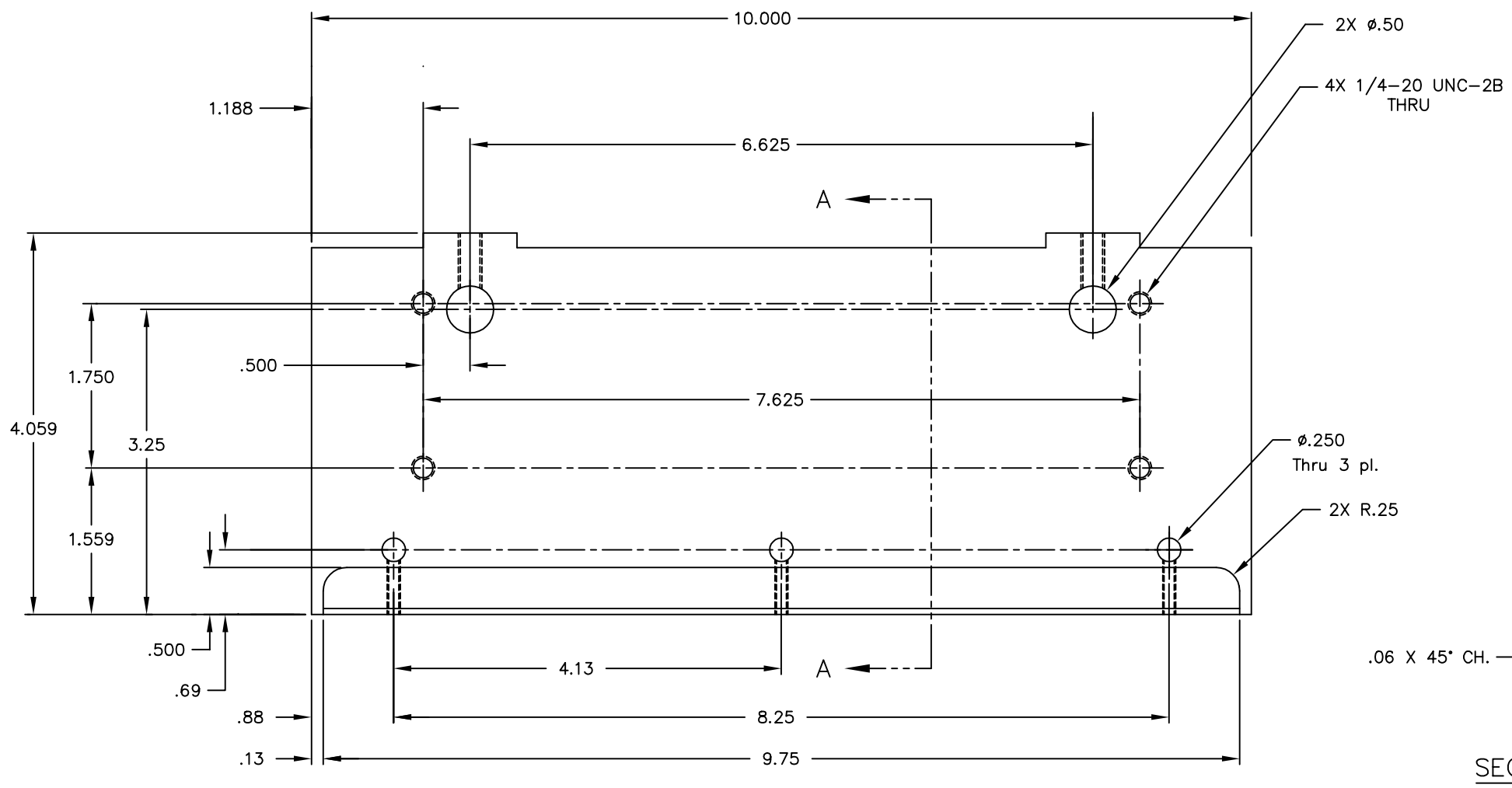
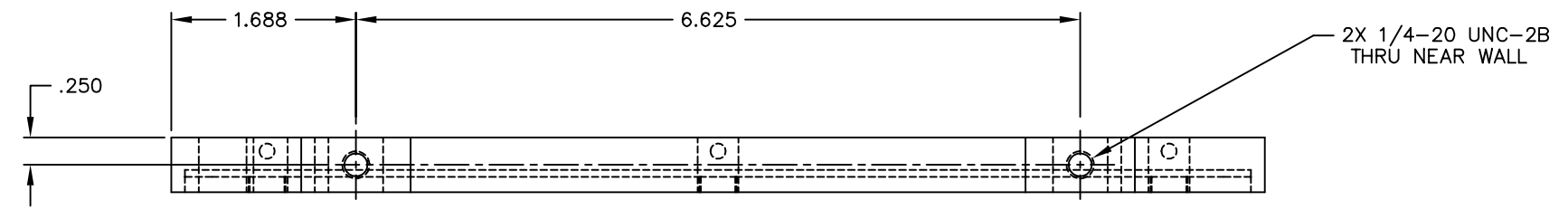

SECTION A-A

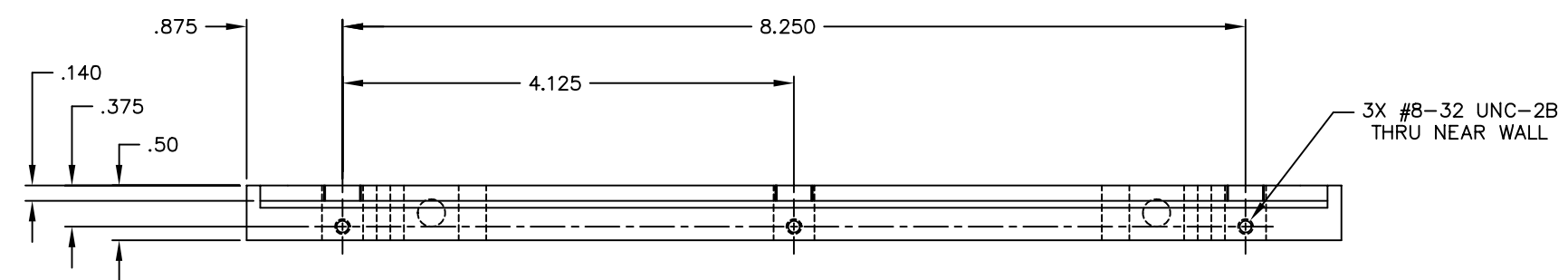
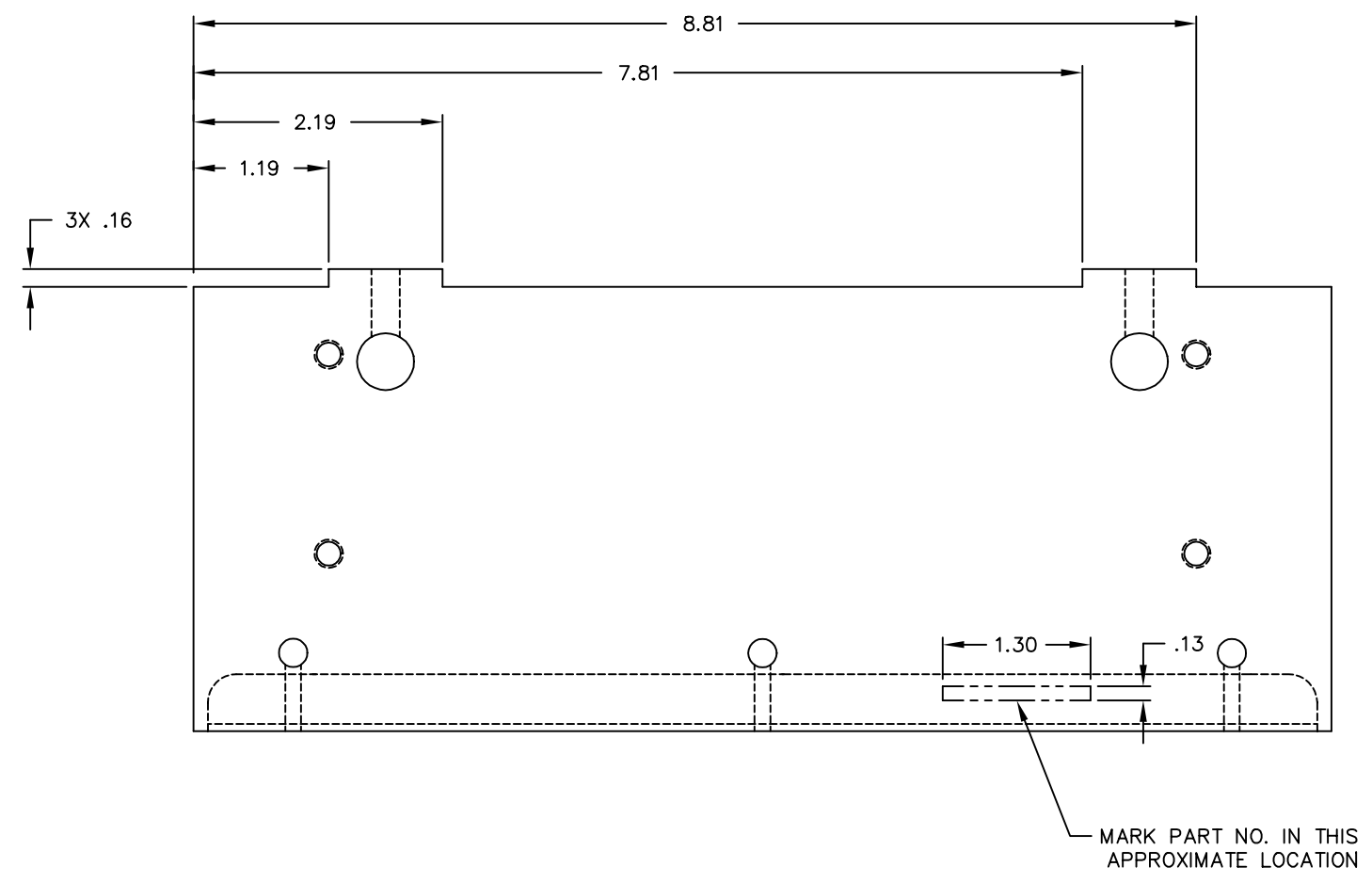

REF. MAKE 1 PER ASSEMBLY

REF	QTY	PART or DRWG No.	DESCRIPTION	MATERIAL
			PLATE, TOP, MIRROR BOX	
00			FOR FABRICATION	
00			PRE-RELEASE	
REV			DESCRIPTION	

UNLESS OTHERWISE SPECIFIED DIMENSIONS ARE IN INCHES		TOLERANCES: FRACTIONAL ± 1/16 ANGULAR ± .25° ANGULAR MACH ± BEND ± TWO PLACE DECIMAL ± .01		THREE PLACE DECIMAL ± .005 FINISHED SURFACE RMS 63 BREAK CORNERS IN .015 DIA. .015 REMOVE ALL BURRS	
MATERIAL:	ALUMINUM TOOLING PLATE	HEAT TREAT:	/	FINISH:	/
USED ON:	XXX	NEXT ASS'Y:	XXX		

APP'D	CHECK	DRWN	DATE	DCN NUMBER	ISSUE DESCRIPTION

CAD FILE	D980542-B	SIZE	DWG. NO. D908542-B
SCALE	1 : 1	SHEET	1 OF 1

7 6 5 4 3 2 1