

Change Summary: Board reconfigured for single 10 Hz pole.

1. C44 not installed
2. C43 not installed
3. R12 changed from 120K to 3.32K
4. R28 and R29 replaced with shorting wires
5. C45 changed from 0.22 uF to 0.47 uF
6. R13 changed from 120K to 33.2K
7. External Resistors (499) were added to implement a DC setpoint and are wired to P1. 6a and 6c, hot and gnd respectively.
8. DAQ wiring was added to pins 5A and 5C, hot/gnd respectively on the p2 connector for the mixer error
9. DAQ wiring was added to pins 6A and 6C, hot/gnd respectively on the p2 connector for the actuator drive

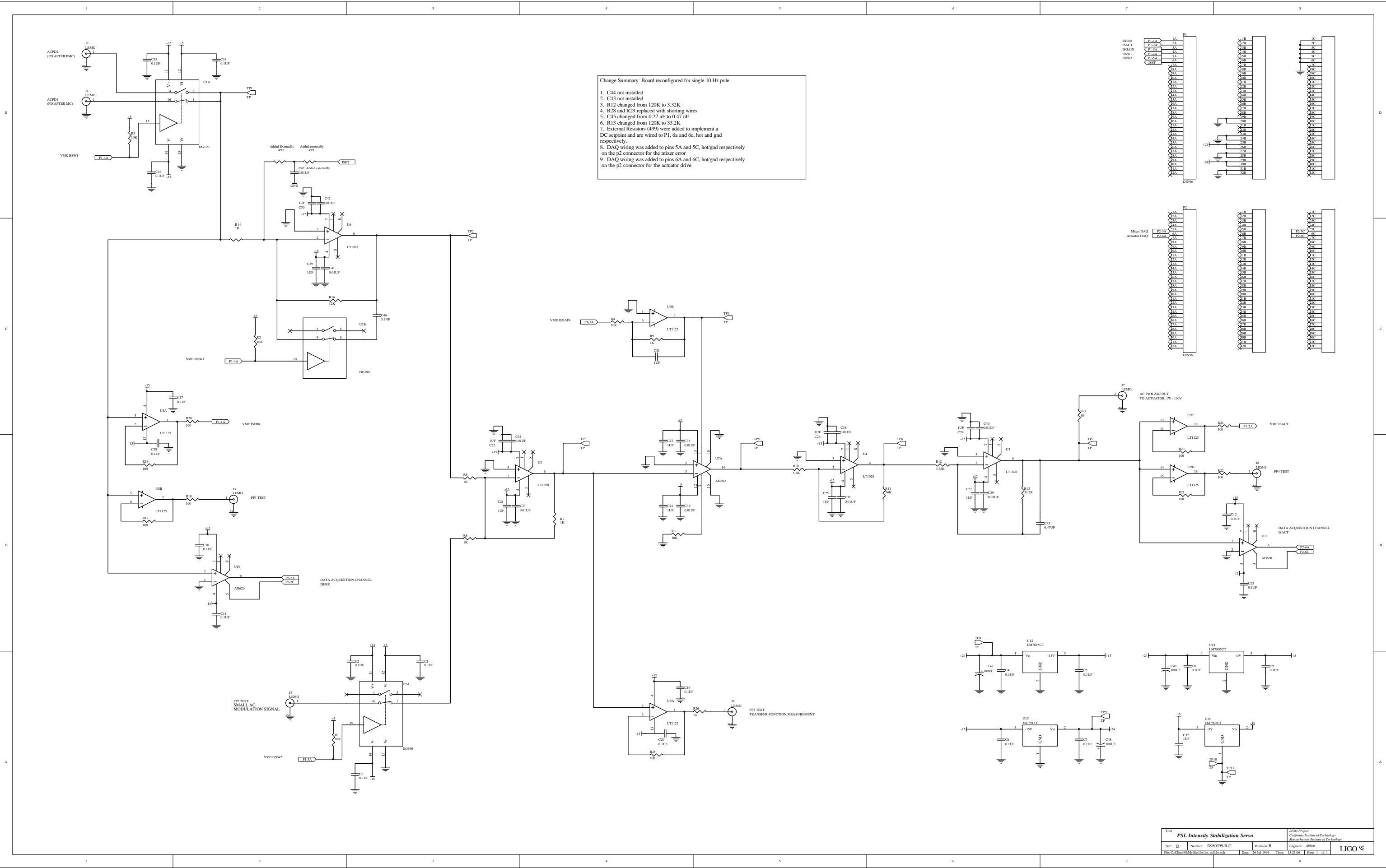

ISERR	ISACT	ISSAIN	ISSW1	ISSW2	ISCT
1A	1A	1A	1A	1A	1A
1B	1B	1B	1B	1B	1B
1C	1C	1C	1C	1C	1C
1D	1D	1D	1D	1D	1D
1E	1E	1E	1E	1E	1E
1F	1F	1F	1F	1F	1F
1G	1G	1G	1G	1G	1G
1H	1H	1H	1H	1H	1H
1I	1I	1I	1I	1I	1I
1J	1J	1J	1J	1J	1J
1K	1K	1K	1K	1K	1K
1L	1L	1L	1L	1L	1L
1M	1M	1M	1M	1M	1M
1N	1N	1N	1N	1N	1N
1O	1O	1O	1O	1O	1O
1P	1P	1P	1P	1P	1P
1Q	1Q	1Q	1Q	1Q	1Q
1R	1R	1R	1R	1R	1R
1S	1S	1S	1S	1S	1S
1T	1T	1T	1T	1T	1T
1U	1U	1U	1U	1U	1U
1V	1V	1V	1V	1V	1V
1W	1W	1W	1W	1W	1W
1X	1X	1X	1X	1X	1X
1Y	1Y	1Y	1Y	1Y	1Y
1Z	1Z	1Z	1Z	1Z	1Z

Mixer DAQ	Actuator DAQ
2A	2A
2B	2B
2C	2C
2D	2D
2E	2E
2F	2F
2G	2G
2H	2H
2I	2I
2J	2J
2K	2K
2L	2L
2M	2M
2N	2N
2O	2O
2P	2P
2Q	2Q
2R	2R
2S	2S
2T	2T
2U	2U
2V	2V
2W	2W
2X	2X
2Y	2Y
2Z	2Z