

8 7 6 5 4 3 2 1

REVISIONS			
REV.	DESCRIPTION	DATE	APPROVED

D

D

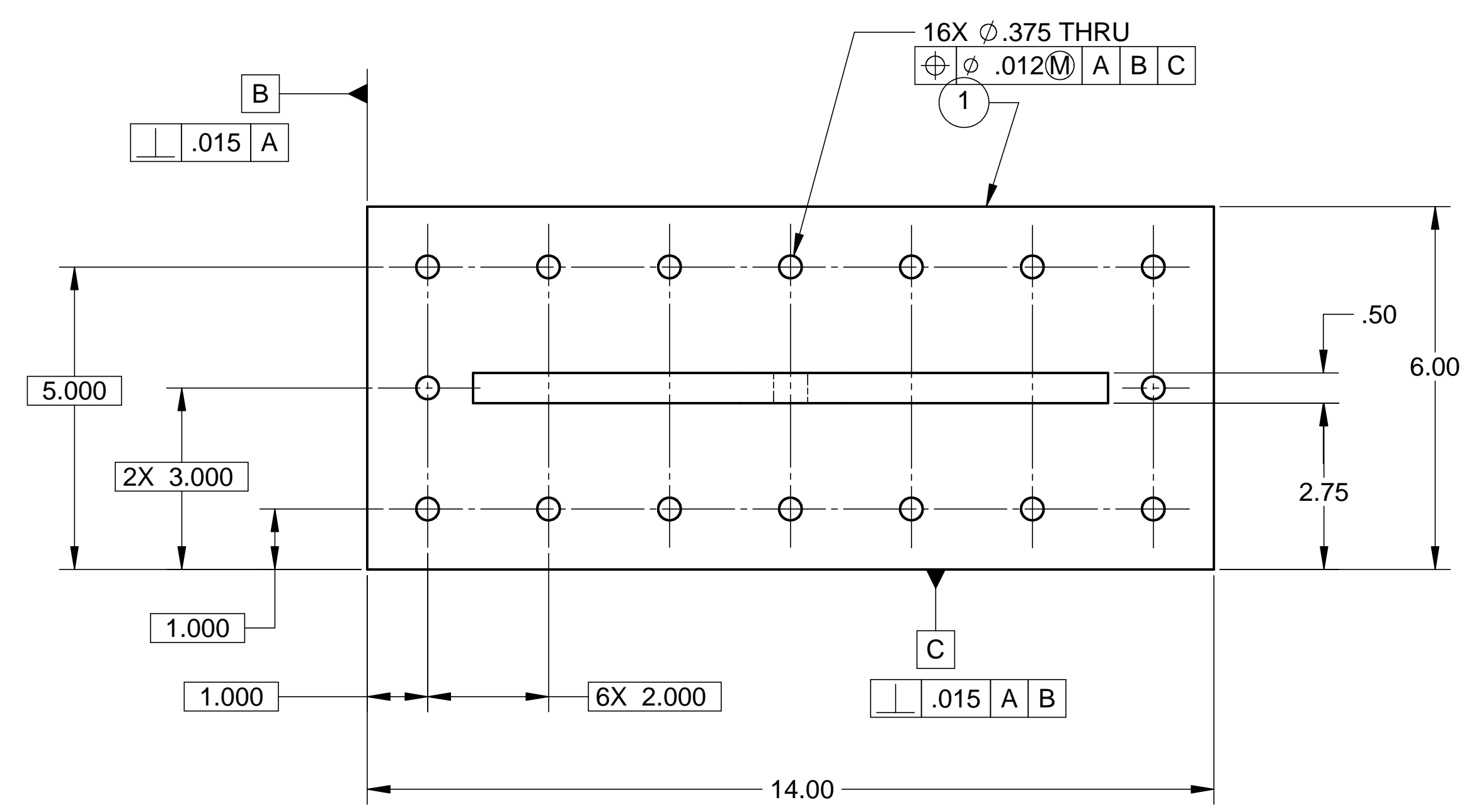

C

C

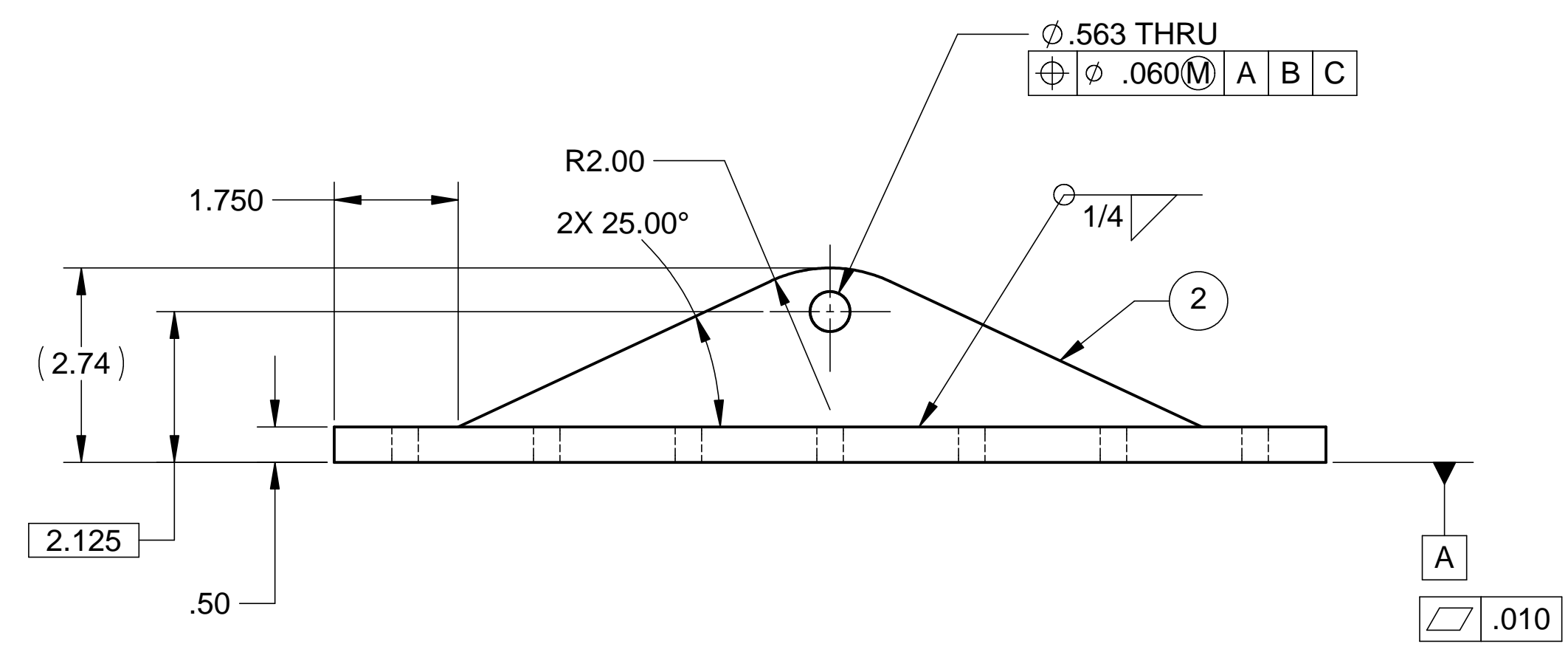

B

B

NOTES: UNLESS OTHERWISE SPECIFIED

- ALL DIMENSIONS IN INCHES
- DIMENSIONS AND TOLERANCING PER ASME Y14.5M-1994
- SURFACE TEXTURE PER ANSI/ASME B 46.1-1985
- REMOVE ALL BURRS AND BREAK SHARP EDGES TO A MAXIMUM OF .015
- ALL INSIDE CORNERS TO BE .015 RADIUS MAX
- COUNTERSINK 82 DEGREES ALL TAPPED HOLES TO MAJOR DIAMETER
- COUNTERSINK 82 DEGREES APPROXIMATELY .015 DEEP ALL DRILLED HOLES
- PARTS TO BE THOROUGHLY CLEANED TO REMOVE ALL OIL, GREASE, DIRT AND CHIPS
- PART NUMBER (DRAWING NO. PLUS DASH NO. PLUS SERIAL NO.) TO BE CLEARLY MARKED ON THE PART ITSELF.
- ALL FABRICATION, CLEANING, AND HANDLING MAINTAINED TO HYTEC SPECIFICATION: LIGO-TS-03 CATEGORY 1.
- NO SULFUR BASED CUTTING FLUIDS ALLOWED. APPROVED STAINLESS STEEL MACHINE LUBRICANT: RELTON A-9, RELTON
- PART WEIGHS 14.6 Lbs.

A

A

ITEM NO.	QTY.	DESCRIPTION	MATERIAL
1	1	PLATE	303 SST
2	1	PLATE	303 SST

PARTS LIST			
UNLESS OTHERWISE SPECIFIED: DIMENSIONS ARE IN INCHES -TOLERANCES-		CAD GENERATED DRAWING, DO NOT MANUALLY UPDATE DO NOT SCALE DRAWING	
DECIMALS .XX = +/- .03 .XXX = +/- .010	ANGULAR = +/- .30° SURFACE FINISH = 250	<p><b>HYTEC, INC</b></p> <p>TITLE <b>HAM OPTICS TABLE HOISTING PLATE WELDMENT</b></p>	
FINISH	SIGNATURE	DATE	DWG. NO. <b>D972963</b> SIZE <b>D</b> SHEET NO. <b>1 of 1</b>
	DESIGNED W. K. MILLER	3-24-98	
	DRAWN W. K. MILLER	3-24-98	
	CHECKED HARRY SALAZAR	-	
PART NO. <b>D972963-1</b>	ENGR. T. THOMPSON	-	
	APPROVED T. THOMPSON	-	SCALE 1/2      REVISION

8 7 6 5 4 3 2 1