

8 7 6 5 4 3 2 1

REVISIONS			
REV.	DESCRIPTION	DATE	APPROVED

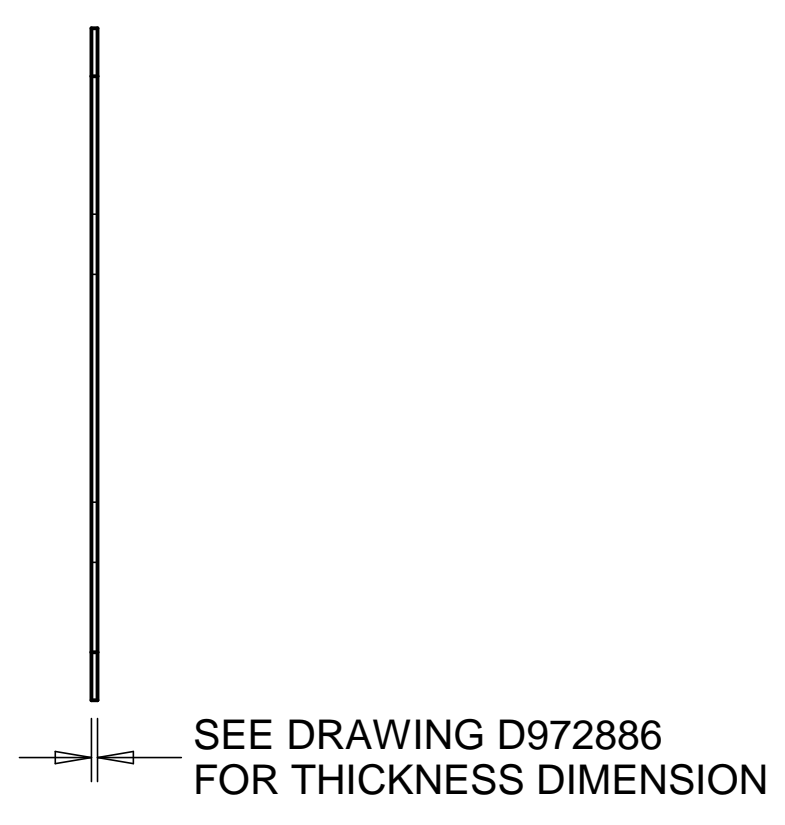
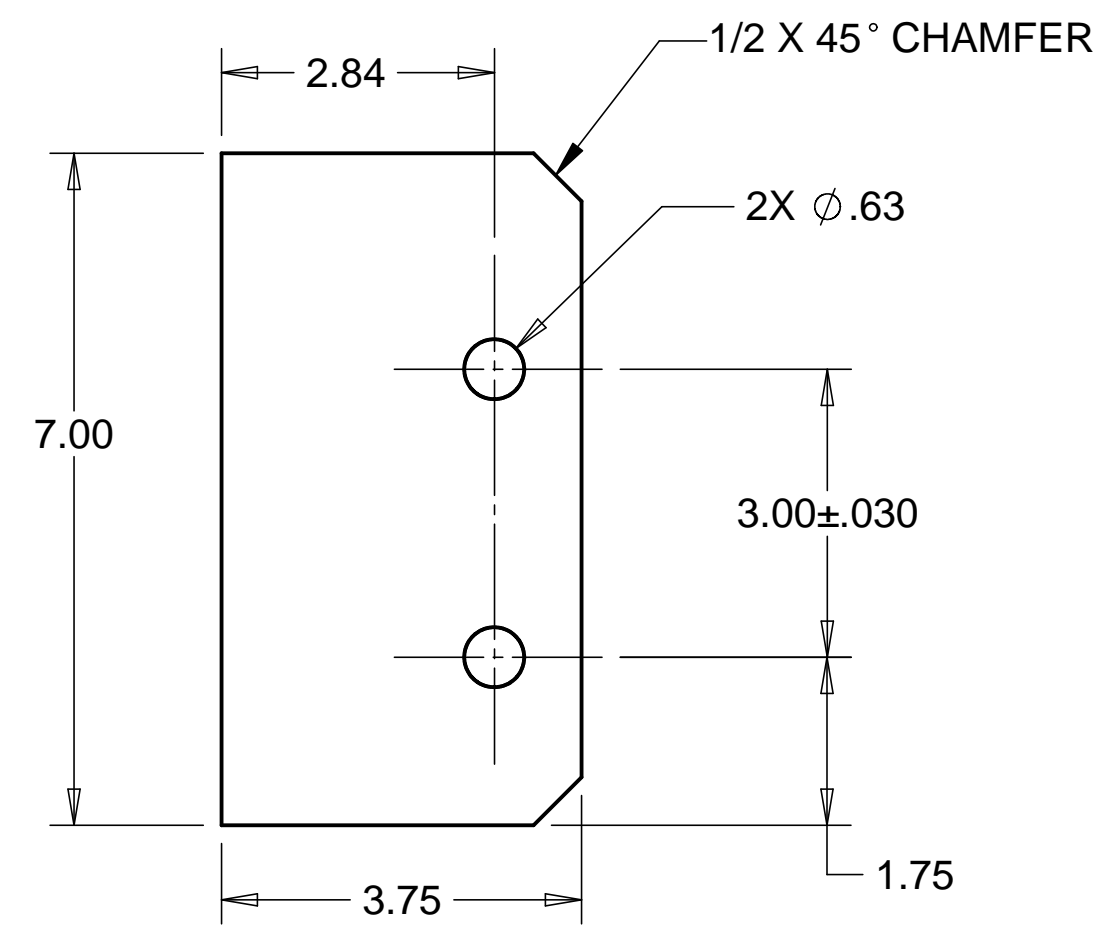

MATL: 303 SST

NOTES: UNLESS OTHERWISE SPECIFIED

1. ALL DIMENSIONS IN INCHES
2. DIMENSIONS AND TOLERANCING PER ASME Y14.5M-1994
3. SURFACE TEXTURE PER ANSI/ASME B 46.1-1985
4. REMOVE ALL BURRS AND BREAK SHARP EDGES TO A MAXIMUM OF .015
5. ALL INSIDE CORNERS TO BE .015 RADIUS MAX
6. COUNTERSINK 82 DEGREES ALL TAPPED HOLES TO MAJOR DIAMETER
7. COUNTERSINK 82 DEGREES APPROXIMATELY .015 DEEP ALL DRILLED HOLES
8. PARTS TO BE THOROUGHLY CLEANED TO REMOVE ALL OIL, GREASE, DIRT, AND CHIPS.
9. PART NUMBER (DRAWING NO. PLUS DASH NO. PLUS SERIAL NO.) TO BE CLEARLY MARKED ON THE PART ITSELF.
10. PART WEIGHS .45 Lbs.

PARTS LIST			
UNLESS OTHERWISE SPECIFIED: DIMENSIONS ARE IN INCHES -TOLERANCES- DECIMALS ANGULAR = +/- 30' .XX = +/- .06 SURFACE FINISH = 250 .XXX = +/- .010	CAD GENERATED DRAWING, DO NOT MANUALLY UPDATE DO NOT SCALE DRAWING		HYTEC, INC
	FINISH		TITLE HAM RAIL SYSTEM MINOR RAIL ANGLE BRACKET SHIM
PART NO. D972955-1	DESIGNED	W. K. MILLER	1/16/98
	DRAWN	W. K. MILLER	1/16/98
	CHECKED	HARRY SALAZAR	2/4/98
	ENGR.	T. THOMPSON	2/4/98
APPROVED	T. THOMPSON	2/4/98	DWG. NO. D972955
SCALE 1/2		SIZE D	SHEET NO. 1 of 1
REVISION			REVISION

8 7 6 5 4 3 2 1

D

D

C

C

B

B

A

A