

8 7 6 5 4 3 2 1

REVISIONS			
REV.	DESCRIPTION	DATE	APPROVED
A	CHANGED PAINT SPECIFICATION, ADDED WELD SYMBOLS	3/18/98	WKM

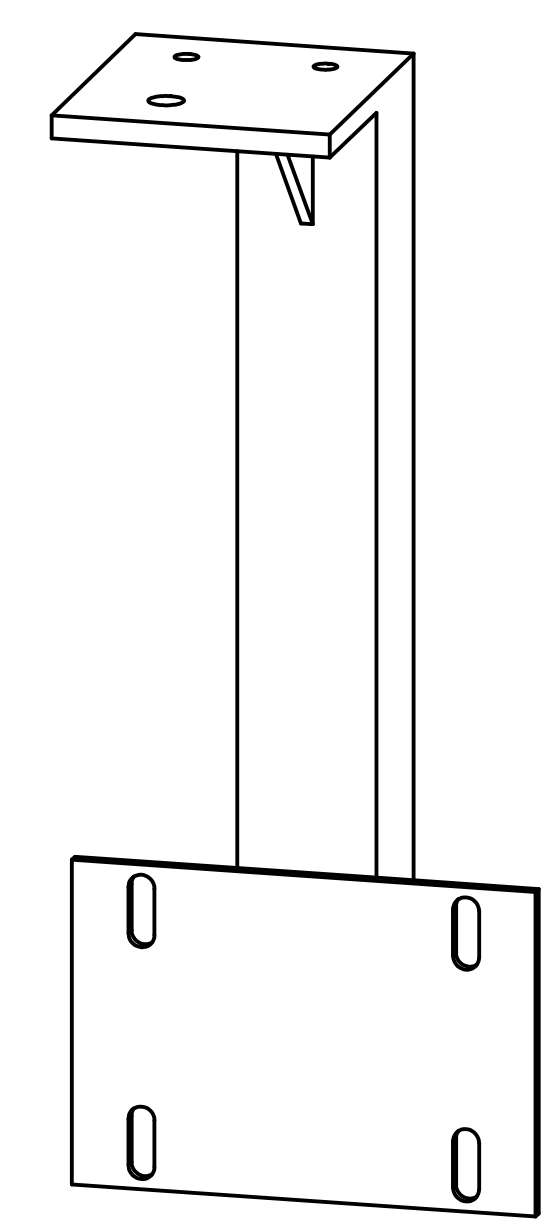
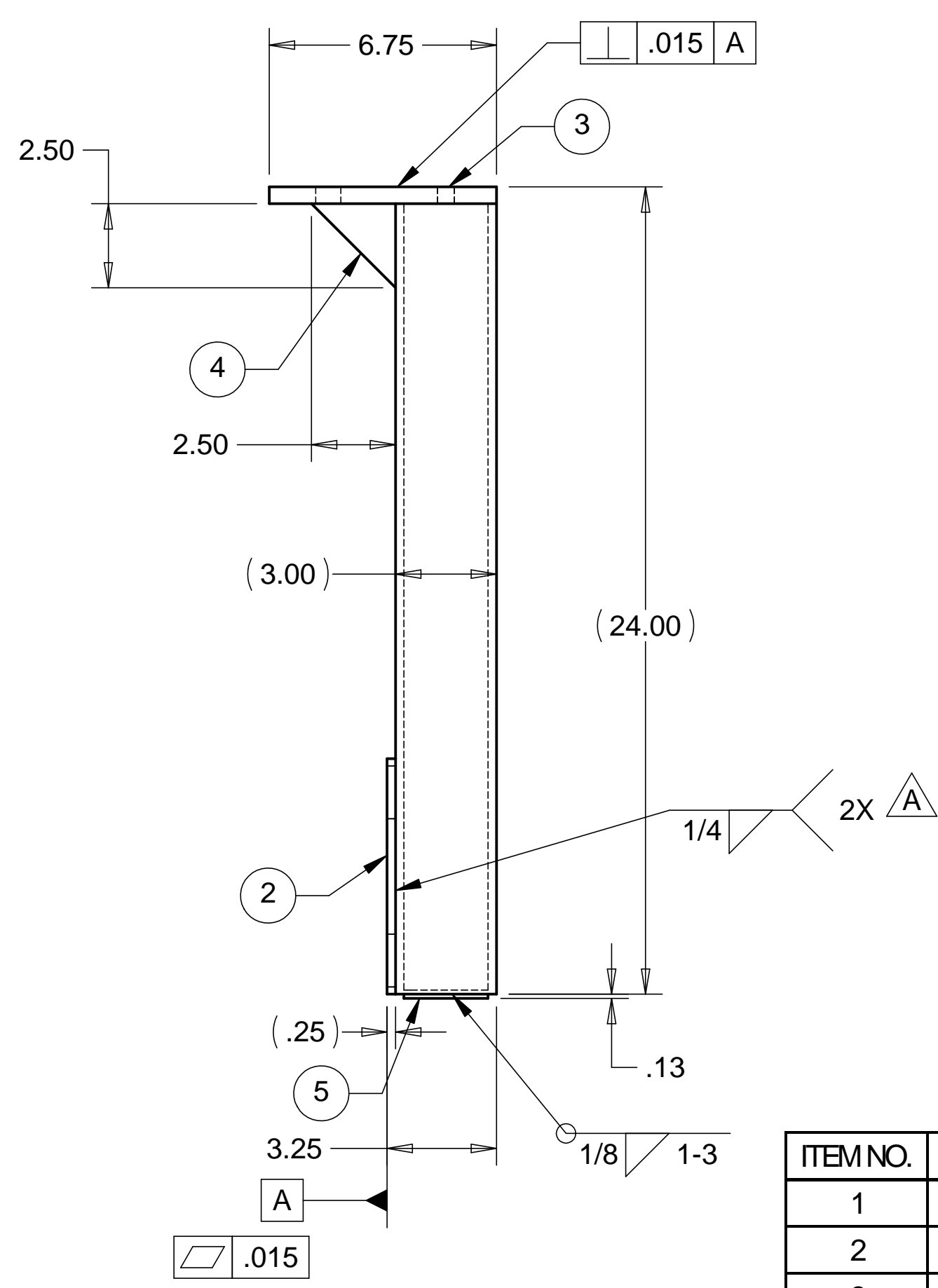
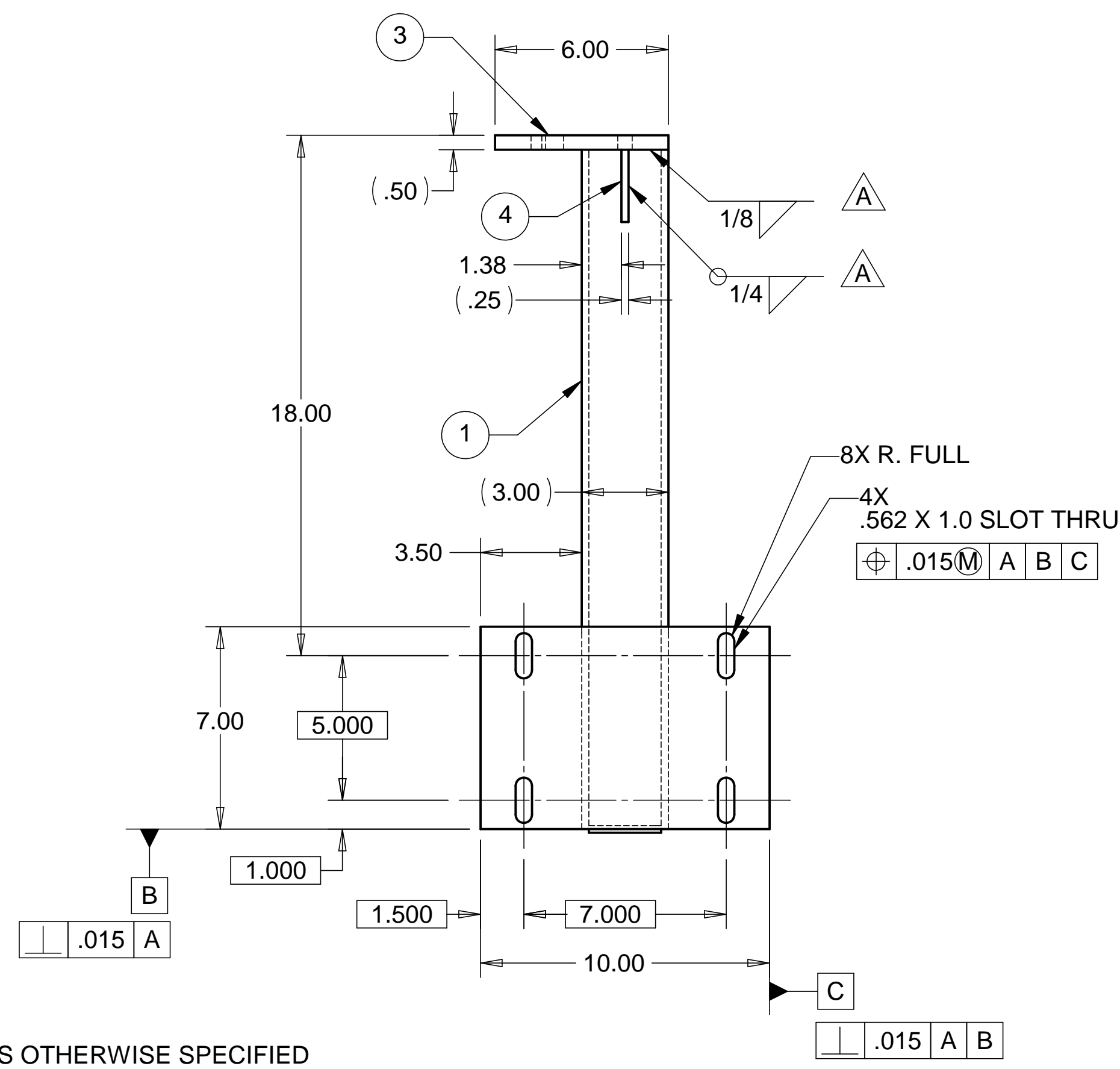
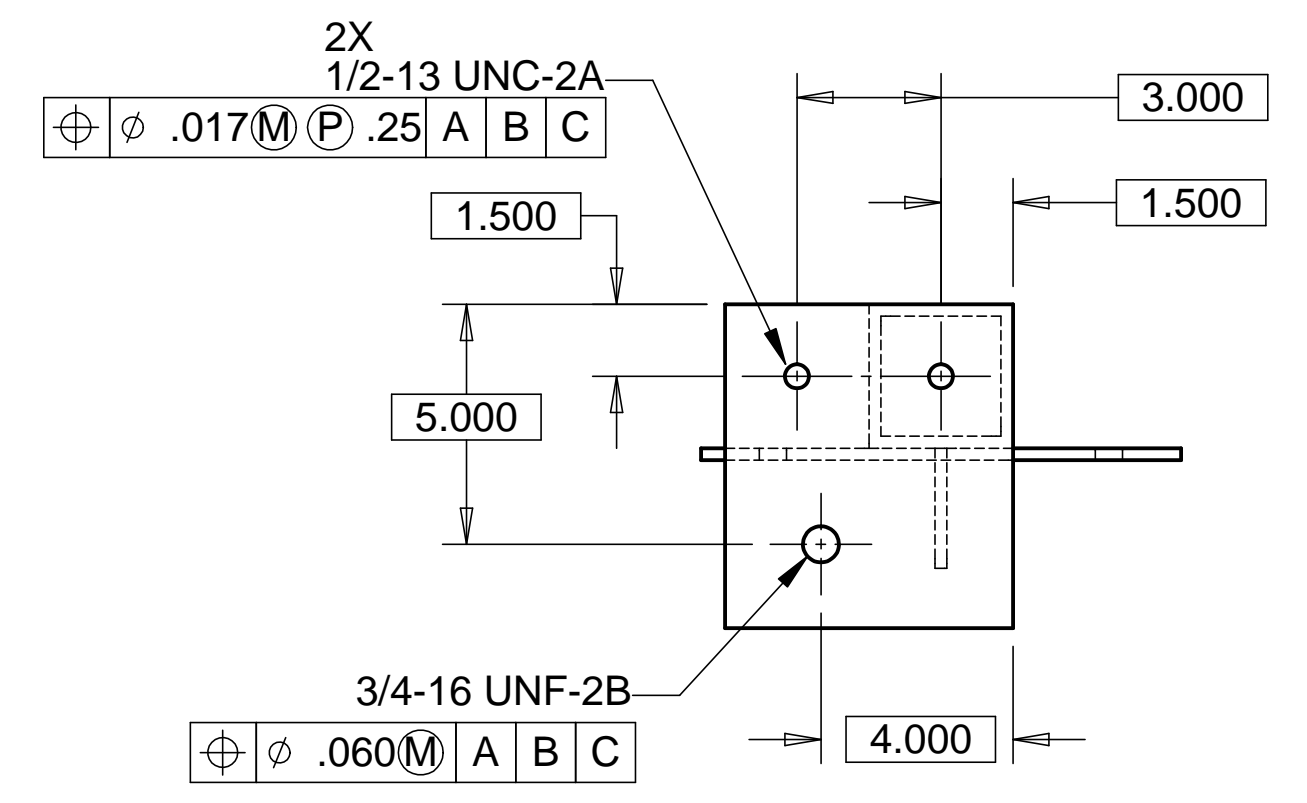

NOTES: UNLESS OTHERWISE SPECIFIED

1. ALL DIMENSIONS IN INCHES
2. DIMENSIONS AND TOLERANCING PER ASME Y14.5M-1994
3. SURFACE TEXTURE PER ANSI/ASME B 46.1-1985
4. REMOVE ALL BURRS AND BREAK SHARP EDGES TO A MAXIMUM OF .015
5. ALL INSIDE CORNERS TO BE .015 RADIUS MAX
6. COUNTERSINK 82 DEGREES ALL TAPPED HOLES TO MAJOR DIAMETER
7. COUNTERSINK 82 DEGREES APPROXIMATELY .015 DEEP ALL DRILLED HOLES
8. PARTS TO BE THOROUGHLY CLEANED TO REMOVE ALL OIL, GREASE, DIRT AND CHIPS
9. PART NUMBER (DRAWING NO. PLUS DASH NO. PLUS SERIAL NO. ) TO BE CLEARLY MARKED ON THE PART ITSELF.
10. PART WEIGHS 29.9 Lbs.
11. PRIMER (ALL VISIBLE SURFACES): SHERMAN WILLIAMS INDUSTRIAL WASH PRIMER PG062.
12. PAINT (ALL VISIBLE SURFACES): SHERMAN WILLIAMS POLANE T POLYURETHANE COLOR JUNCTION YELLOW, COLOR #F63TXY-0310-4352.

ITEM NO.	QTY.	DESCRIPTION	MATERIAL
1	1	TUBING, 3 X 3 X .25 WALL	A36 STEEL
2	1	PLATE	1010 STEEL
3	1	PLATE	1010 STEEL
4	1	PLATE, 1/4" THK	1010 STEEL
5	1	PLATE, 1/4" THK	1010 STEEL

PARTS LIST				HYTEC, INC	
UNLESS OTHERWISE SPECIFIED: DIMENSIONS ARE IN INCHES -TOLERANCES-		CAD GENERATED DRAWING, DO NOT MANUALLY UPDATE DO NOT SCALE DRAWING		TITLE <b>HAM CROSSBEAM BRACKET BASE WELDMENT (LEFT)</b>	
DECIMALS .XX = +/- .03 .XXX = +/- .010	ANGULAR = +/- .30° SURFACE FINISH = 250	SIGNATURE	DATE	DWG. NO.	SIZE SHEET NO.
FINISH		DESIGNED W. K. MILLER	12/18/97	D972929	D 1 of 1
		DRAWN W. K. MILLER	12/18/97		
PART NO. D972929-1		CHECKED HARRY SALAZAR	3/13/98		
		ENGR. T. THOMPSON	3/13/98		
		APPROVED T. THOMPSON	3/13/98	SCALE 1/4"	REVISION A

8 7 6 5 4 3 2 1