

8 7 6 5 4 3 2 1

REVISIONS			
REV.	DESCRIPTION	DATE	APPROVED

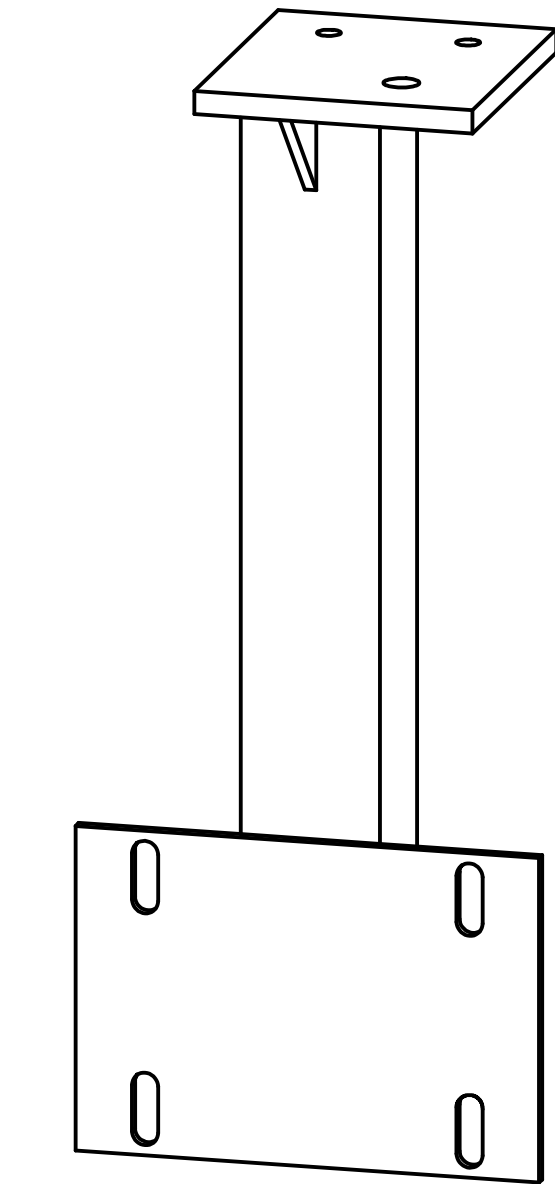
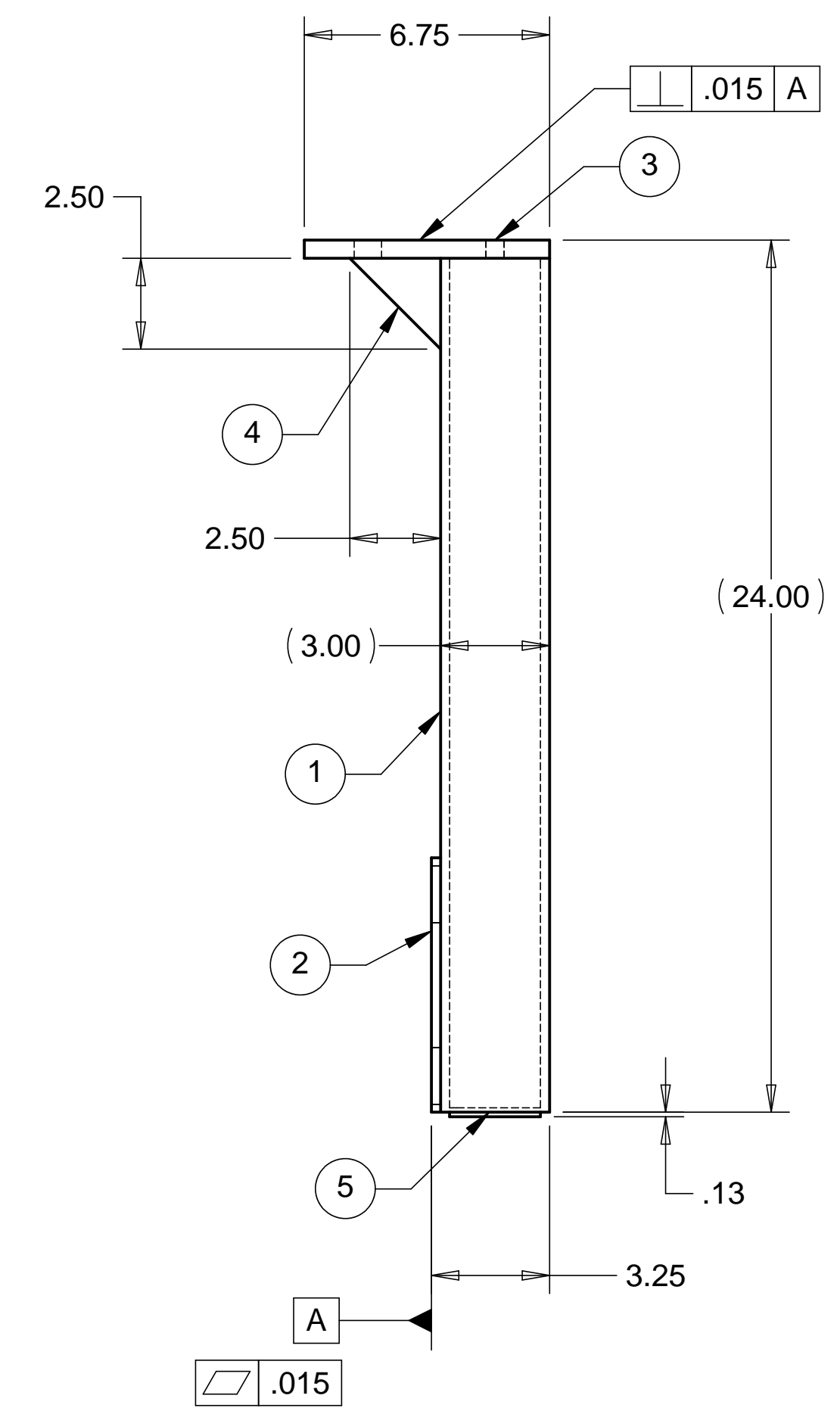
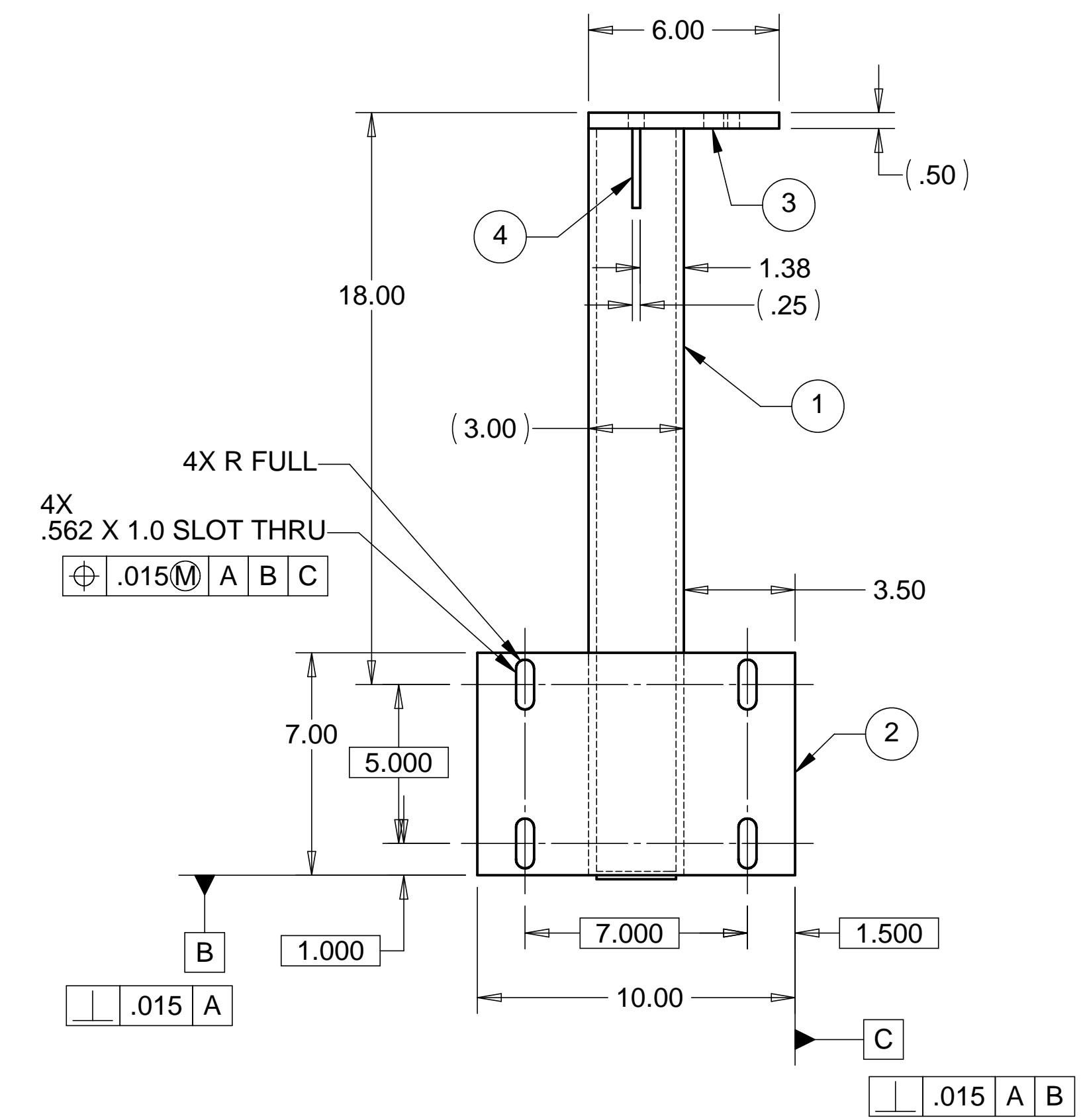
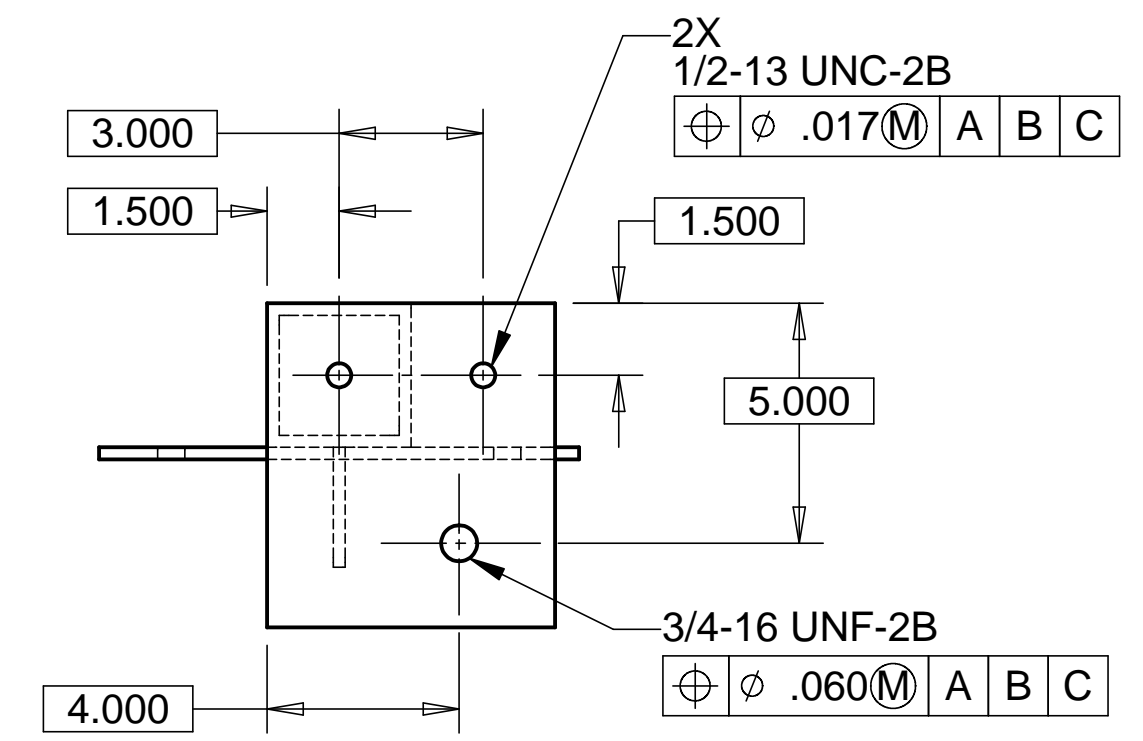

NOTES: UNLESS OTHERWISE SPECIFIED

- ALL DIMENSIONS IN INCHES
- DIMENSIONS AND TOLERANCING PER ASME Y14.5M-1994
- SURFACE TEXTURE PER ANSI/ASME B 46.1-1985
- REMOVE ALL BURRS AND BREAK SHARP EDGES TO A MAXIMUM OF .015
- ALL INSIDE CORNERS TO BE .015 RADIUS MAX
- COUNTERSINK 82 DEGREES ALL TAPPED HOLES TO MAJOR DIAMETER
- COUNTERSINK 82 DEGREES APPROXIMATELY .015 DEEP ALL DRILLED HOLES
- PARTS TO BE THOROUGHLY CLEANED TO REMOVE ALL OIL, GREASE, DIRT AND CHIPS
- PART NUMBER (DRAWING NO. PLUS DASH NO. PLUS SERIAL NO.) TO BE CLEARLY MARKED ON THE PART ITSELF.
- PART WEIGHS 30 Lbs.
- PAINT PART USING SHERMAN WILLIAMS MEDIUM TEXTURED BEIGE (D13 POLANE T-PLUS, POLYURETHANE ENAMEL, F63 SERIES, #SW-F63TX-H-1651-5864).

ITEM NO.	QTY.	DESCRIPTION	MATERIAL
1	1	TUBING, 3 X 3 X .25 WALL	A36 STEEL
2	1	PLATE	1010 STEEL
3	1	PLATE	1010 STEEL
4	1	PLATE, 1/4" THK	1010 STEEL
5	1	PLATE, 1/4" THK	1010 STEEL

PARTS LIST			
UNLESS OTHERWISE SPECIFIED: DIMENSIONS ARE IN INCHES -TOLERANCES-		CAD GENERATED DRAWING, DO NOT MANUALLY UPDATE DO NOT SCALE DRAWING	
DECIMALS .XX = +/- .03 .XXX = +/- .010	ANGULAR = +/- 30' SURFACE FINISH = 250	HYTEC, INC TITLE HAM CROSSBEAM BRACKET BASE WELDMENT (RIGHT)	
FINISH	SIGNATURE	DATE	DWG. NO.
	DESIGNED W. K. MILLER	12/18/98	SIZE SHEET NO.
	DRAWN W. K. MILLER	12/18/98	D972925 D 1 of 1
PART NO. D972925-1	CHECKED HARRY SALAZAR	-	SCALE 1/4
	ENGR. T. THOMPSON	-	REVISION
	APPROVED T. THOMPSON	-	

8 7 6 5 4 3 2 1