

8 7 6 5 4 3 2 1

REVISIONS			
REV.	DESCRIPTION	DATE	APPROVED
A	SEE ECN# D972713-A FOR CHANGE LIST	11-03-97	T. THOMPSON
B	SEE ECN# D972713-B FOR CHANGE LIST	04-15-98	T. THOMPSON

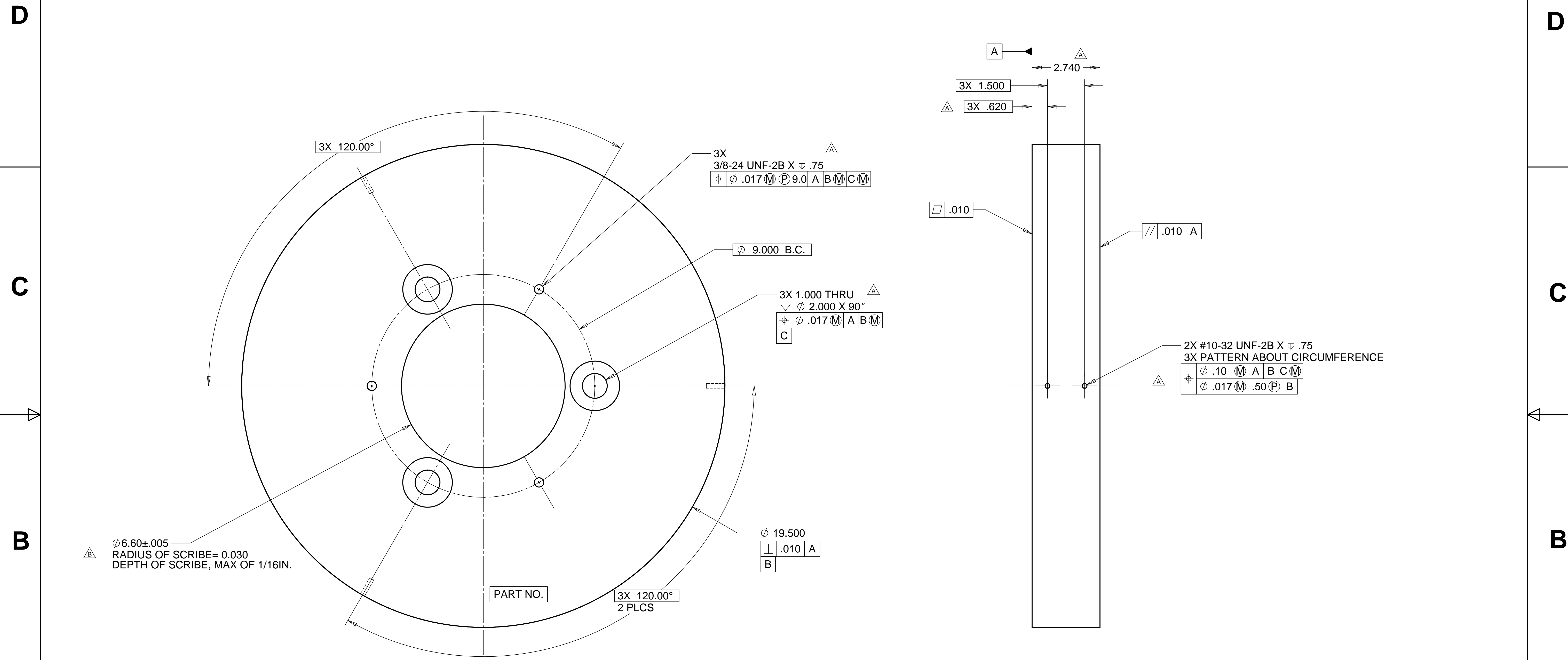

NOTES: UNLESS OTHERWISE SPECIFIED

- ALL DIMENSIONS IN INCHES
- DIMENSIONS AND TOLERANCING PER ASME Y14.5M-1994
- SURFACE TEXTURE PER ANSI/ASME B 46.1-1985
- REMOVE ALL BURRS AND BREAK SHARP EDGES TO A MAXIMUM OF .015
- ALL INSIDE CORNERS TO BE .015 RADIUS MAX
- COUNTERSINK 82 DEGREES ALL TAPPED HOLES TO MAJOR DIAMETER
- COUNTERSINK 82 DEGREES APPROXIMATELY .015 DEEP ALL DRILLED HOLES
- PARTS TO BE THOROUGHLY CLEANED TO REMOVE ALL OIL, GREASE, DIRT AND CHIPS
- PART NUMBER (DRAWING NO. PLUS DASH NO. PLUS SERIAL NO. ) TO BE CLEARLY MARKED ON THE PART ITSELF.
- ALL FABRICATION, CLEANING, AND HANDLING MAINTAINED TO HYTEC SPECIFICATION: LIGO-TS-03 CATEGORY 1.
- NO SULFUR BASED CUTTING FLUIDS ALLOWED. APPROVED STAINLESS STEEL MACHINE LUBRICANT: RELTON A-9, RELTON

MATL: 304 SST

WEIGHT: 234.5 lbs.

PARTS LIST			
UNLESS OTHERWISE SPECIFIED: DIMENSIONS ARE IN INCHES -TOLERANCES- DECIMALS: X = +/- .1 .XX = +/- .03 .XXX = +/- .010 ANGULAR = +/- .30° SURFACE FINISH = 250	CAD GENERATED DRAWING. DO NOT MANUALLY UPDATE DO NOT SCALE DRAWING		<b>HYTEC, INC</b> TITLE LIGO HAM ISOLATION STACK LEG ELEMENT #2
	FINISH <b>ALL MACHINED SURFACES            64 RMS</b>	SIGNATURE DESIGNED: ROGER L. SMITH DRAWN: ROGER L. SMITH CHECKED: HARRY SALAZAR ENGR.: T. THOMPSON APPROVED: T. THOMPSON	
PART NO. <b>D972713-1</b>	DWG. NO. <b>D972713</b>		SIZE SHEET NO. <b>D 1 of 1</b>
SCALE 1/2		REVISION B	

8 7 6 5 4 3 2 1