

REVISIONS			
REV.	DESCRIPTION	DATE	APPROVED

ITEM NO.	QTY.	QTY.	PART NO.	DESCRIPTION
1	1	1		HAM CHAMBER
2	1	1	D972710-1	OPTICAL TABLE
3	4	4	D972701-1	ISOLATION STACK LEG ASSEMBLY
4	1	1	D972711-1	SUPPORT TABLE WELDMENT
5	12	12	D972715-3	ISOLATION STACK LEG SCREW #2
6	12	12	D972715-5	ISOLATION STACK SAFETY PIN
7	2	2	D972610-1	SUPPORT TUBE WELDMENT
8	4	4	D972611-1	EXPANSION BELLOW
9	4	4	D972614-1	SUPPORT TUBE MOUNTING CAP
10	4	4	D972613-1	SUPPORT TUBE MOUNTING BASE
11	4	4	D972615-1	SPHERICAL BEARING
12	2	2	D972612-1	CROSSBEAM WELDMENT
13	16	16	D972418-1	PIER PLATE ADAPTOR MOUNTING CLAMP
14	2	2	D972102-1	COARSE X-Y DRIVEN TRANSLATION ASSEMBLY
15	2	2	D972103-1	COARSE X-Y FLOATING TRANSLATION ASSEMBLY
16	4	4	D972104-3	SCISSORS TABLE ASSEMBLY
17	4	4	D972904-1	PIER PLATE ADAPTER
18	AR	AR		GROUT
19	4	0	D972609-1	SUPPORT PIER (HANFORD)
19	0	4	D972609-3	SUPPORT PIER (LIVINGSTON)
20	4	4	D972126-1	PIER LEVELING & GROUT PLATE
21	18	18		SOC HD SST VENTED SCREW, 3/8-24 UNF-2A X 1.25 LG
22	4	4	MDC # 191025	COPPER GASKET
23	120	120	MDC # 190013	SOC HD SST SCREW, (3/8-24 UNC-2A X 2.0 LG)
24	4	4	MDC # 191017	COPPER GASKET
25	64	64		SOC HD SST SCREW, 5/16-24 UNF-2A X 1.5 LG
26	16	16		SOC HD SST SCREW, 1/2-20 UNF-2A X 3.0 LG
27	16	16		SOC HD SST SCREW, 1/2-20 UNF-2A X 4.0 LG
28	32	32		SOC HD SST SCREW, 1/2-13 UNC-2A X 2.25 LG
29	16	16		SOC HD SST SCREW, 3/8-16 UNC-2A X 1.50 LG
30	42	42	WFV-38	VENTED WASHER, U-C COMPONENTS, INC.
31	16	16	806-34-812	BARNHILL BOLT THREADED ANCHOR, 3/4-10 UNC-2A WITH 4.5" THREAD LENGTH
32	16	16		NUT, 3/4-10 UNC-2B
33	16	16		FLAT WASHER, 3/4
34	16	16		SOC HD SST SCREW, 1/4-20 UNC-2A X 1.25 LG
35	32	32	D972146-1	SCISSORS TABLE MOUNTING CLAMP
36	32	32		SOC HD SST SCREW, 1/2-13 UNC-2A X 3.5 LG
37	16	16		FLAT WASHER, 3/8
DASH #	-1	-3		

- 1 ASSEMBLY FOR HANFORD
- 3 ASSEMBLY FOR LIVINGSTON

PARTS LIST				TITLE	
UNLESS OTHERWISE SPECIFIED: DIMENSIONS ARE IN INCHES -TOLERANCES-		CAD GENERATED DRAWING, DO NOT MANUALLY UPDATE DO NOT SCALE DRAWING		<b>HYTEC, INC</b>  LIGO HAM TOP ASSEMBLY	
DECIMALS .XX = +/- .03 .XXX = +/- .010	ANGULAR = +/- .30° SURFACE FINISH = 250	SIGNATURE	DATE		
FINISH		DESIGNED ROGER L. SMITH	5-28-97	DWG. NO.	SIZE
		DRAWN ROGER L. SMITH	04-08-98	D972501	D
PART NO.		CHECKED HARRY SALAZAR	04-29-98	1 of 5	
D972501-1 & 3		ENGR. T. THOMPSON	05-04-98		
		APPROVED T. THOMPSON	05-04-98	SCALE NONE	REVISION

8 7 6 5 4 3 2 1

REVISIONS			
REV.	DESCRIPTION	DATE	APPROVED

D

D

C

C

B

B

A

A

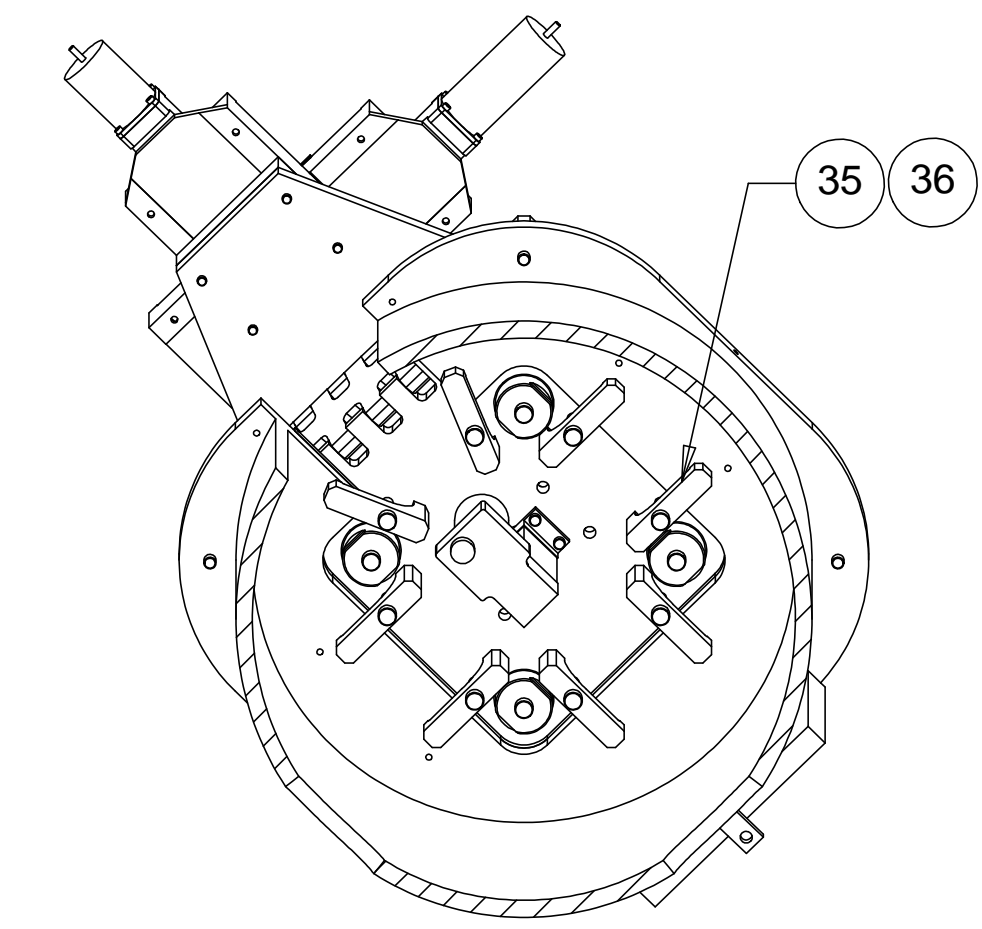
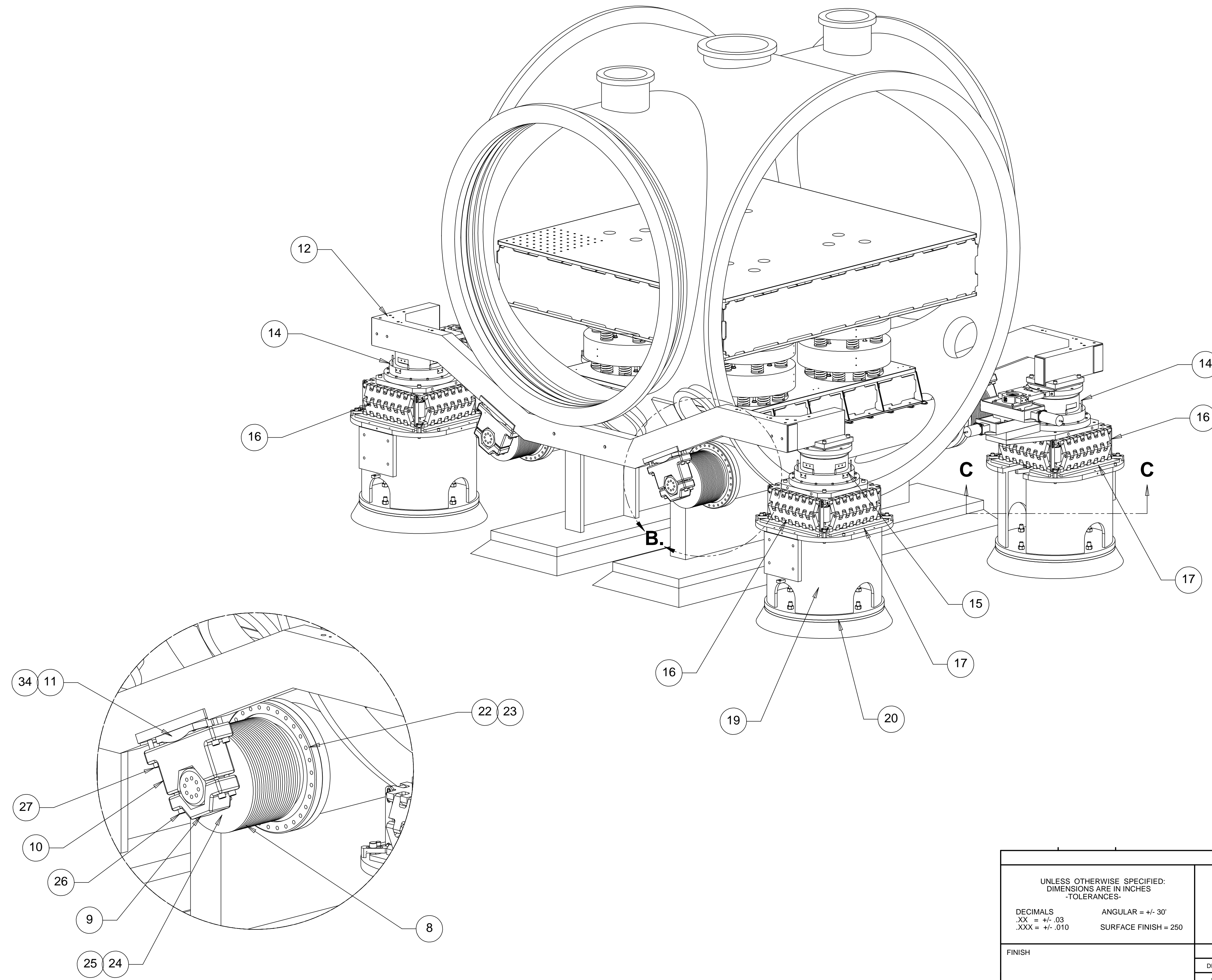

SECTION C - C  
TYP AT ALL PIERS

DETAIL B  
TYP 4 PLACES  
SCALE 1:6

PARTS LIST			
UNLESS OTHERWISE SPECIFIED: DIMENSIONS ARE IN INCHES -TOLERANCES-	CAD GENERATED DRAWING. DO NOT MANUALLY UPDATE DO NOT SCALE DRAWING		<b>HYTEC, INC</b> TITLE <b>LIGO HAM TOP ASSEMBLY</b>
	DECIMALS .XX = +/- .03 .XXX = +/- .010	ANGULAR = +/- 30' SURFACE FINISH = 250	
FINISH	SIGNATURE	DATE	SIZE SHEET NO.
	DESIGNED ROGER L. SMITH	5-28-97	D 2 of 5
	DRAWN ROGER L. SMITH	5-28-97	
	CHECKED HARRY SALAZAR	5-12-98	
	ENGR. T. THOMPSON	5-12-98	
	APPROVED T. THOMPSON	5-12-98	REVISION
PART NO. <b>D972501-1</b>			SCALE NONE

8 7 6 5 4 3 2 1

8 7 6 5 4 3 2 1

REVISIONS			
REV.	DESCRIPTION	DATE	APPROVED

D

D

C

C

B

B

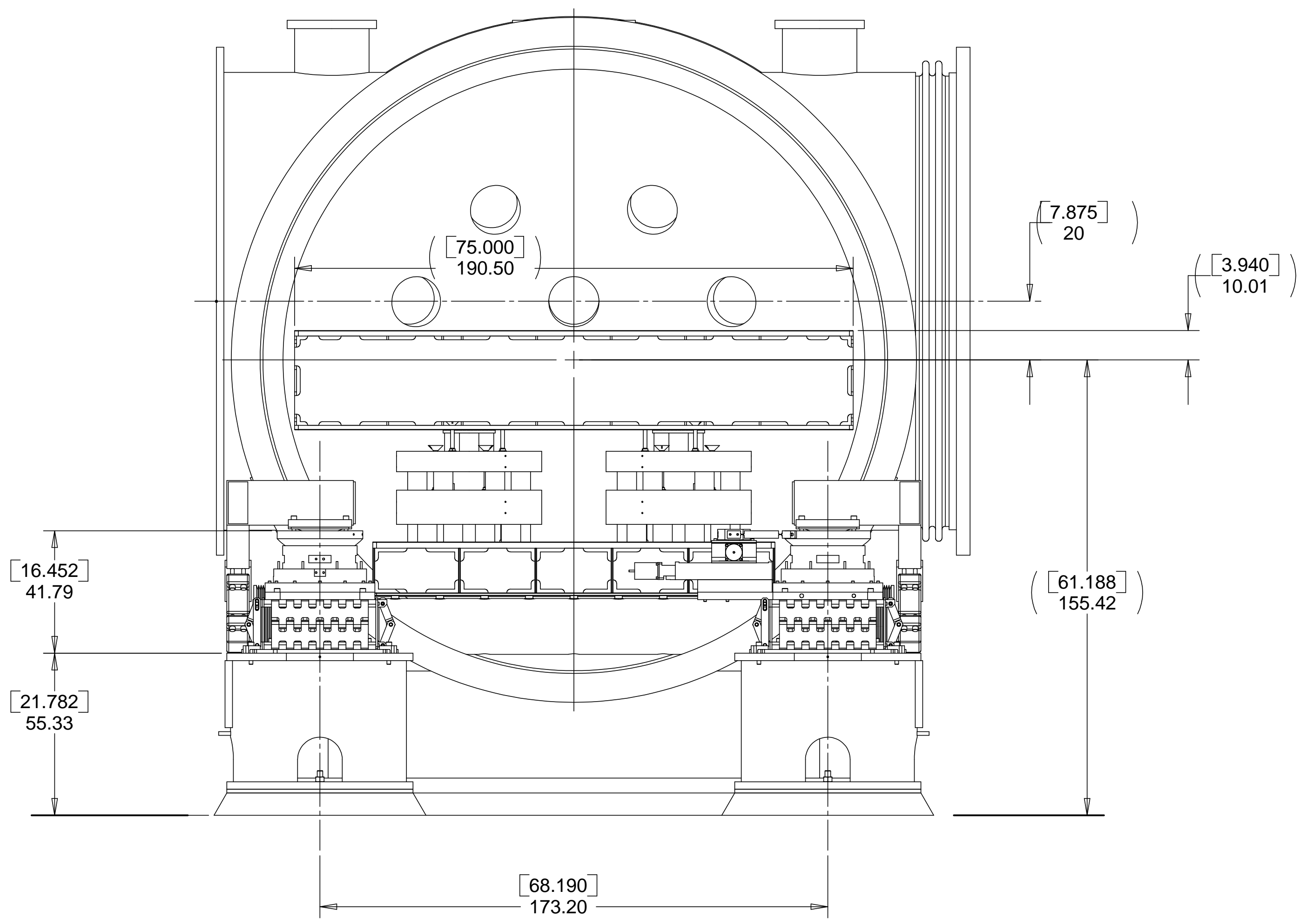

IN  
CM

A

A

8 7 6 5 4 3 2 1

PARTS LIST			
UNLESS OTHERWISE SPECIFIED: DIMENSIONS ARE IN INCHES -TOLERANCES-  DECIMALS      ANGULAR = +/- 30' .XX = +/- .03      SURFACE FINISH = 250 .XXX = +/- .010	CAD GENERATED DRAWING, DO NOT MANUALLY UPDATE DO NOT SCALE DRAWING		<b>HYTEC, INC</b>
	FINISH		TITLE <b>LIGO HAM TOP ASSEMBLY</b>
PART NO.  <b>D972501-1</b>	DESIGNED	ROGER L. SMITH	5-28-97
	DRAWN	ROGER L. SMITH	5-28-97
	CHECKED	HARRY SALAZAR	6-6-97
	ENGR.	T. THOMPSON	7-10-97
APPROVED	T. THOMPSON	7-10-97	SCALE 1/12
DWG. NO. <b>D972501</b>		SIZE <b>D</b>	SHEET NO. <b>3 of 5</b>
REVISION		REVISION	

8 7 6 5 4 3 2 1

REVISIONS			
REV.	DESCRIPTION	DATE	APPROVED

D

D

C

C

B

B

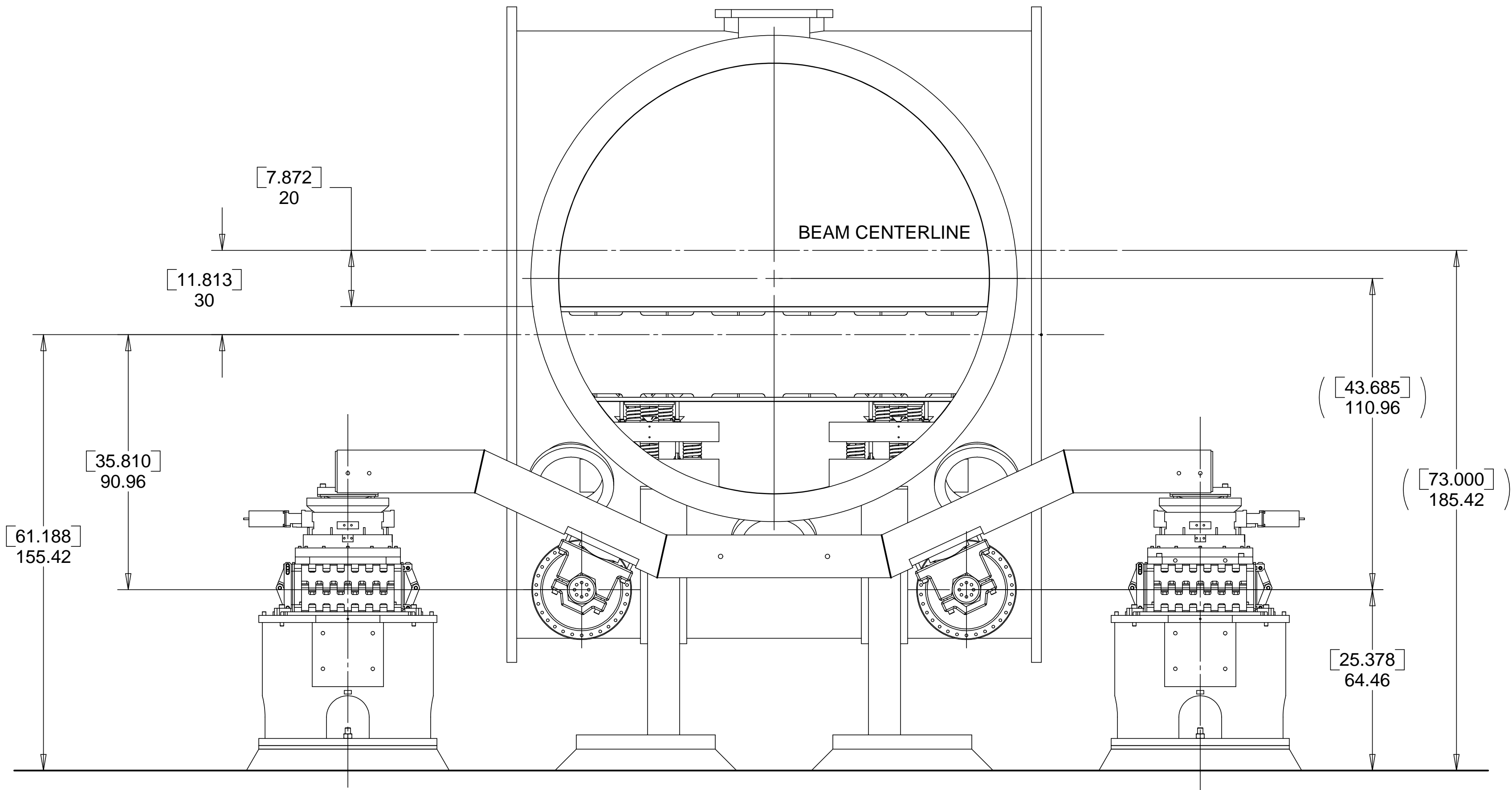

A

A

8 7 6 5 4 3 2 1

IN  
CM

PARTS LIST				
UNLESS OTHERWISE SPECIFIED: DIMENSIONS ARE IN INCHES -TOLERANCES-  DECIMALS      ANGULAR = +/- 30' .XX = +/- .03      SURFACE FINISH = 250 .XXX = +/- .010	CAD GENERATED DRAWING, DO NOT MANUALLY UPDATE DO NOT SCALE DRAWING		<b>HYTEC, INC</b>	
	FINISH		TITLE <b>LIGO HAM TOP ASSEMBLY</b>	
PART NO.  <b>D972501-1</b>	DESIGNED	ROGER L. SMITH	5-28-97	
	DRAWN	ROGER L. SMITH	5-28-97	
	CHECKED	HARRY SALAZAR	5-12-98	
	ENGR.	T. THOMPSON	5-12-98	
APPROVED	T. THOMPSON	5-12-98	SCALE 1/12	REVISION
DWG. NO. <b>D972501</b>		SIZE <b>D</b>	SHEET NO. <b>4 of 5</b>	

8 7 6 5 4 3 2 1

REVISIONS			
REV.	DESCRIPTION	DATE	APPROVED

D

D

C

C

B

B

A

A

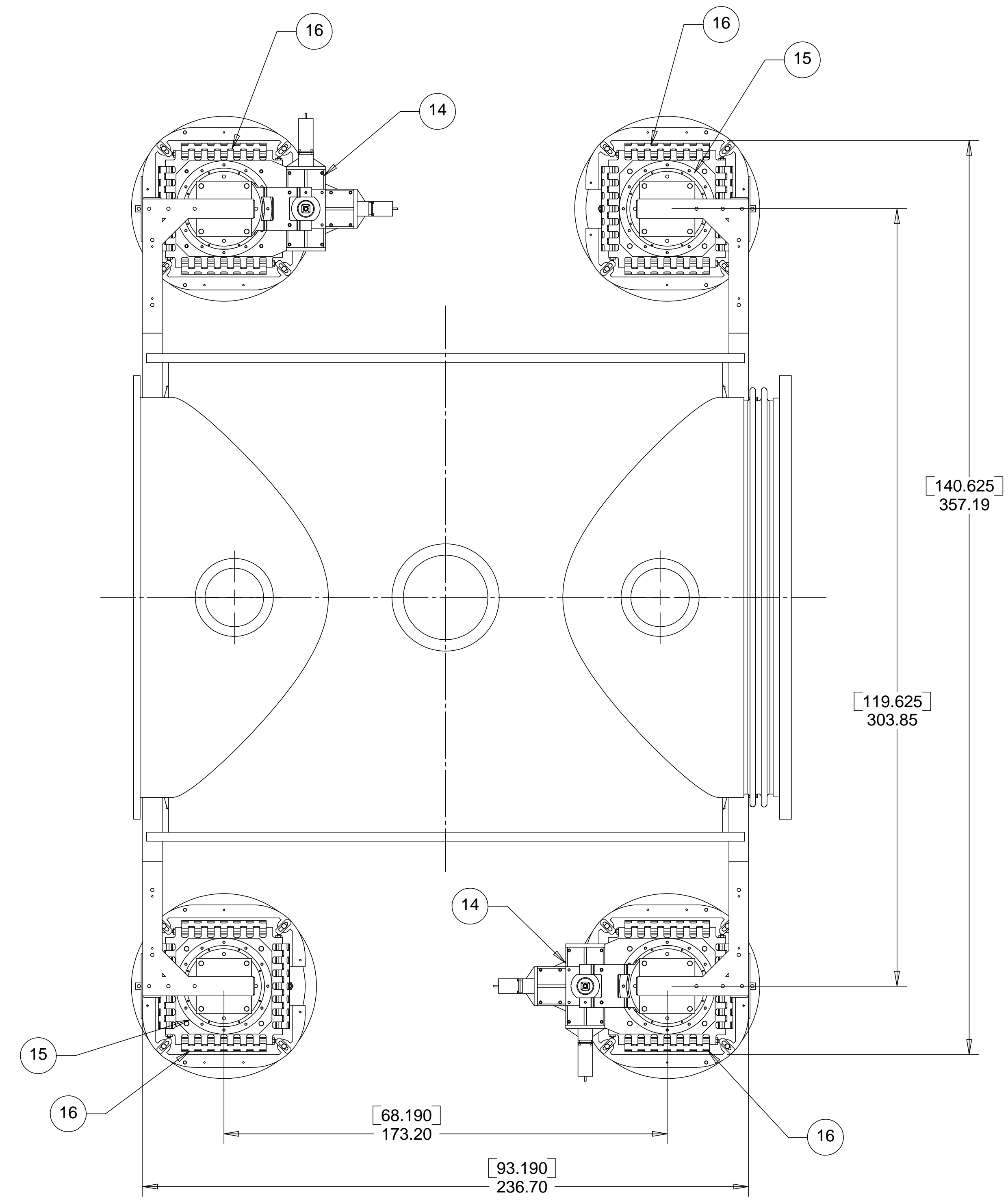

IN  
CM

8 7 6 5 4 3 2 1

PARTS LIST			
UNLESS OTHERWISE SPECIFIED: DIMENSIONS ARE IN INCHES -TOLERANCES-	CAD GENERATED DRAWING, DO NOT MANUALLY UPDATE DO NOT SCALE DRAWING		<b>HYTEC, INC</b> TITLE <b>LIGO HAM TOP ASSEMBLY</b>
	DECIMALS .XX = +/- .03 .XXX = +/- .010	ANGULAR = +/- .30' SURFACE FINISH = 250	
FINISH	SIGNATURE	DATE	SIZE SHEET NO. <b>D 5 of 5</b>
PART NO. <b>D972501-1</b>	DESIGNED	ROGER L. SMITH	5-28-97
	DRAWN	ROGER L. SMITH	5-28-97
	CHECKED	HARRY SALAZAR	5-12-98
	ENGR.	T. THOMPSON	5-12-98
	APPROVED	T. THOMPSON	5-12-98
		SCALE 1/1	REVISION