

8 7 6 5 4 3 2 1

REV.	DESCRIPTION	DATE	APPROVED
A	SEE ECN FOR CHANGES	3-20-98	WKM

D
C
B
A

D
C
B
A

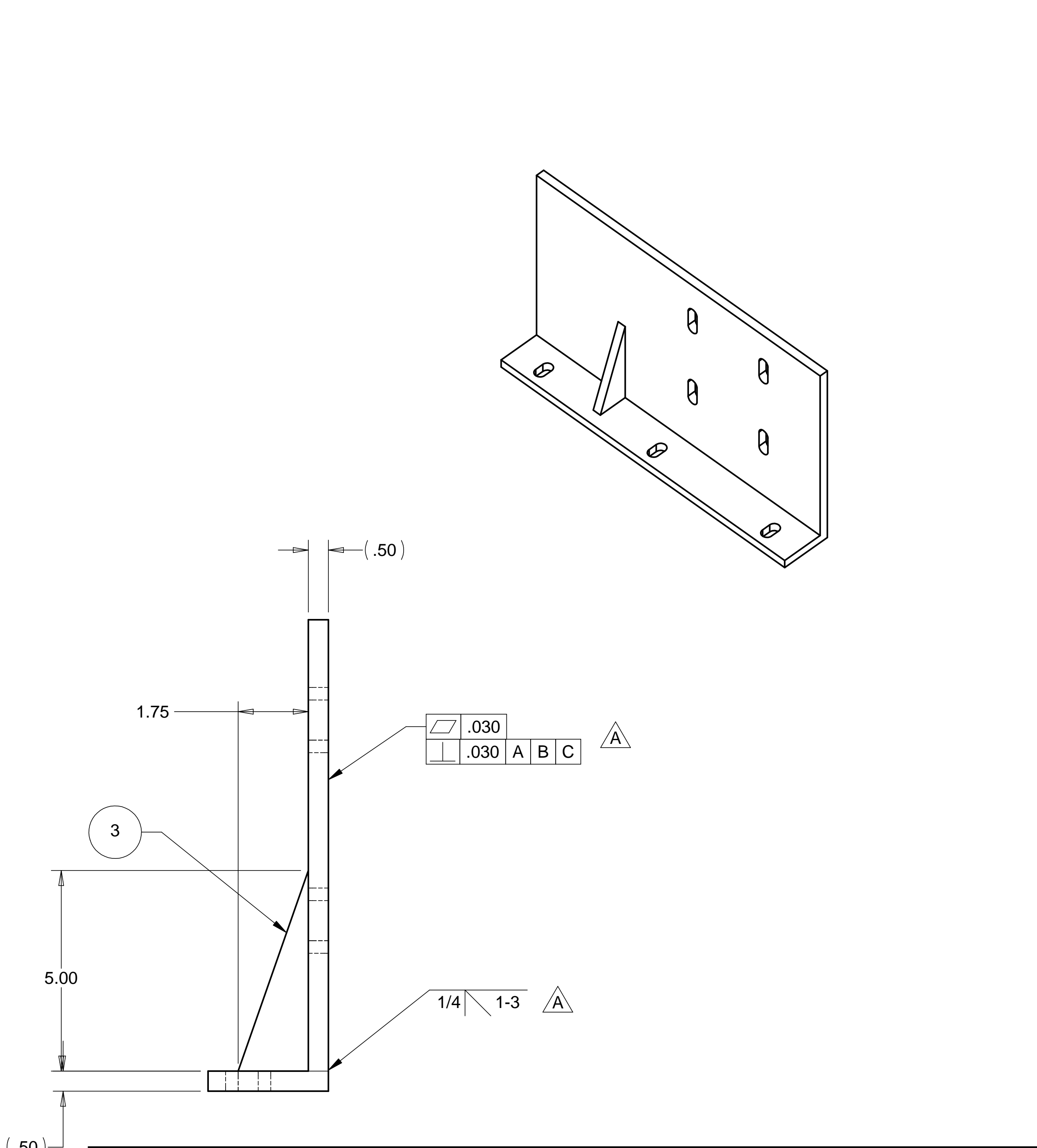
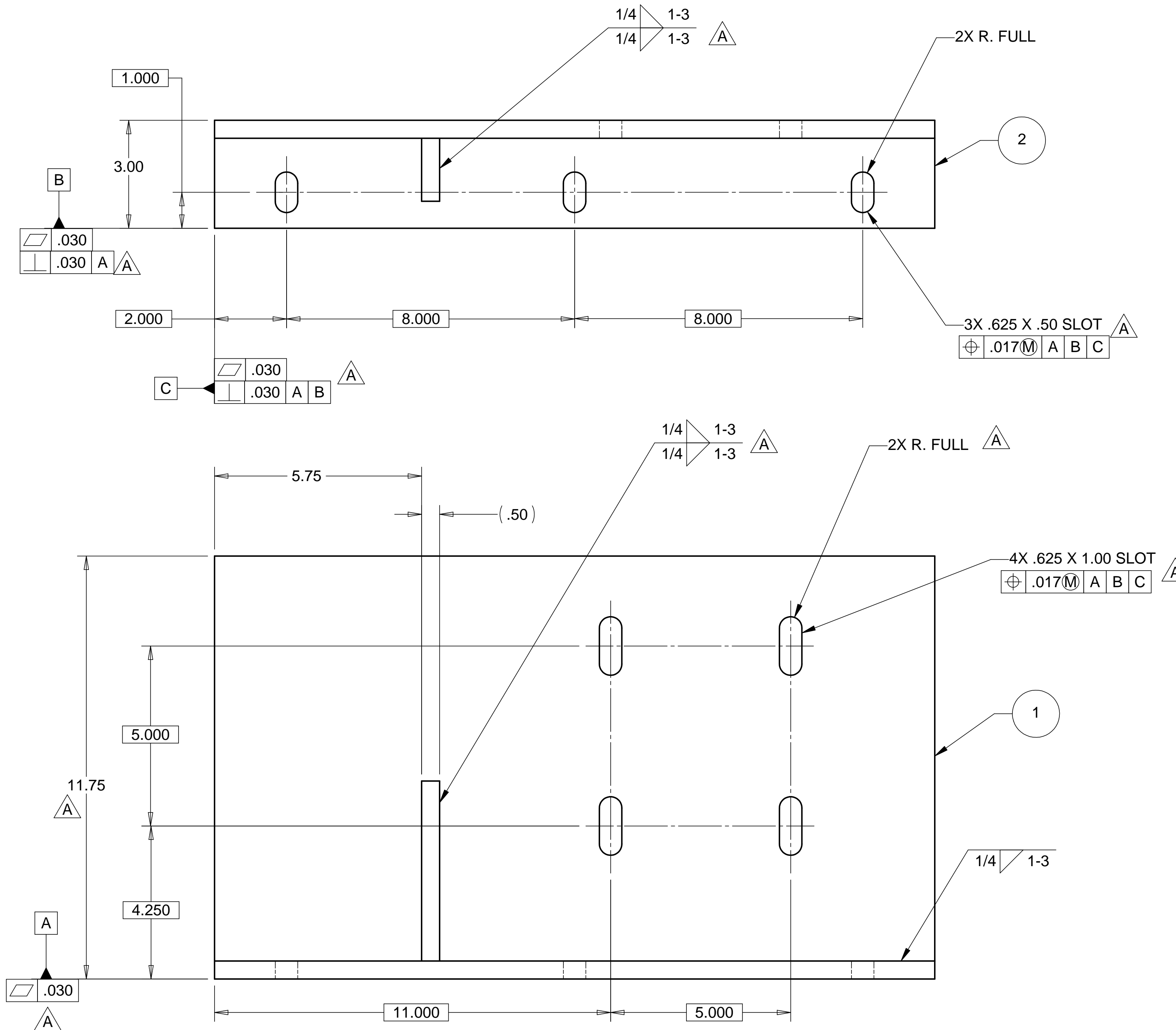

NOTES: UNLESS OTHERWISE SPECIFIED

1. ALL DIMENSIONS IN INCHES
2. DIMENSIONS AND TOLERANCING PER ANAS1 Y14.5M-1994
3. SURFACE TEXTURE PER ANI/ASME B 46.1-1985
4. REMOVE ALL BURRS AND BREAK SHARP EDGES TO A MAXIMUM OF .015
5. ALL INSIDE CORNERS TO BE .015 RADIUS MAX
6. COUNTERSINK 82 DEGREES ALL TAPPED HOLES TO MAJOR DIAMETER
7. COUNTERSINK 82 DEGREES APPROXIMATELY .015 DEEP ALL DRILLED HOLES
8. PARTS TO BE THOROUGHLY CLEANED TO REMOVE ALL OIL, GREASE, DIRT AND CHIPS
9. PART NUMBER (DRAWING NO. PLUS DASH NO. PLUS SERIAL NO.) TO BE CLEARLY MARKED ON THE PART ITSELF.
10. PART WEIGHS 41.00 lbs.
11. PRIMER (ALL VISIBLE SURFACES): SHERMAN WILLIAMS INDUSTRIAL WASH PRIMER PG062.
12. PAINT (ALL VISIBLE SURFACES): SHERMAN WILLIAMS POLANE T POLYURETHANE COLOR BASIN, COLOR #F63TXL-4054-4352 FLAT.

ITEM NO.	QTY.	DESCRIPTION	MATERIAL
1	1	PLATE, .50 THK.	1010 MILD STEEL
2	1	PLATE, .50 THK.	1010 MILD STEEL
3	1	PLATE, .50 THK.	1010 MILD STEEL

PARTS LIST				HYTEC, INC	
UNLESS OTHERWISE SPECIFIED: DIMENSIONS ARE IN INCHES -TOLERANCES-		CAD GENERATED DRAWING, DO NOT MANUALLY UPDATE DO NOT SCALE DRAWING		TITLE BSC CROSSBEAM BRACKET CLAMP WELDMENT (LEFT)	
DECIMALS .X = +/- .1 .XX = +/- .03 .XXX = +/- .010	ANGULAR = +/- .30' SURFACE FINISH = 250	SIGNATURE DESIGNED W. K. MILLER DRAWN GERALD BUSTOS CHECKED HARRY SALAZAR ENGR. T. THOMPSON APPROVED T. THOMPSON	DATE 2-1-98 2-1-98 ----	DWG. NO. D972434	SIZE SHEET NO. D 1 of 1
PART NO. D972434-1		SCALE 1/2		REVISION A	

8 7 6 5 4 3 2 1