

8 7 6 5 4 3 2 1

REVISIONS		
REV.	DESCRIPTION	DATE

D

D

C

C

B

B

A

A

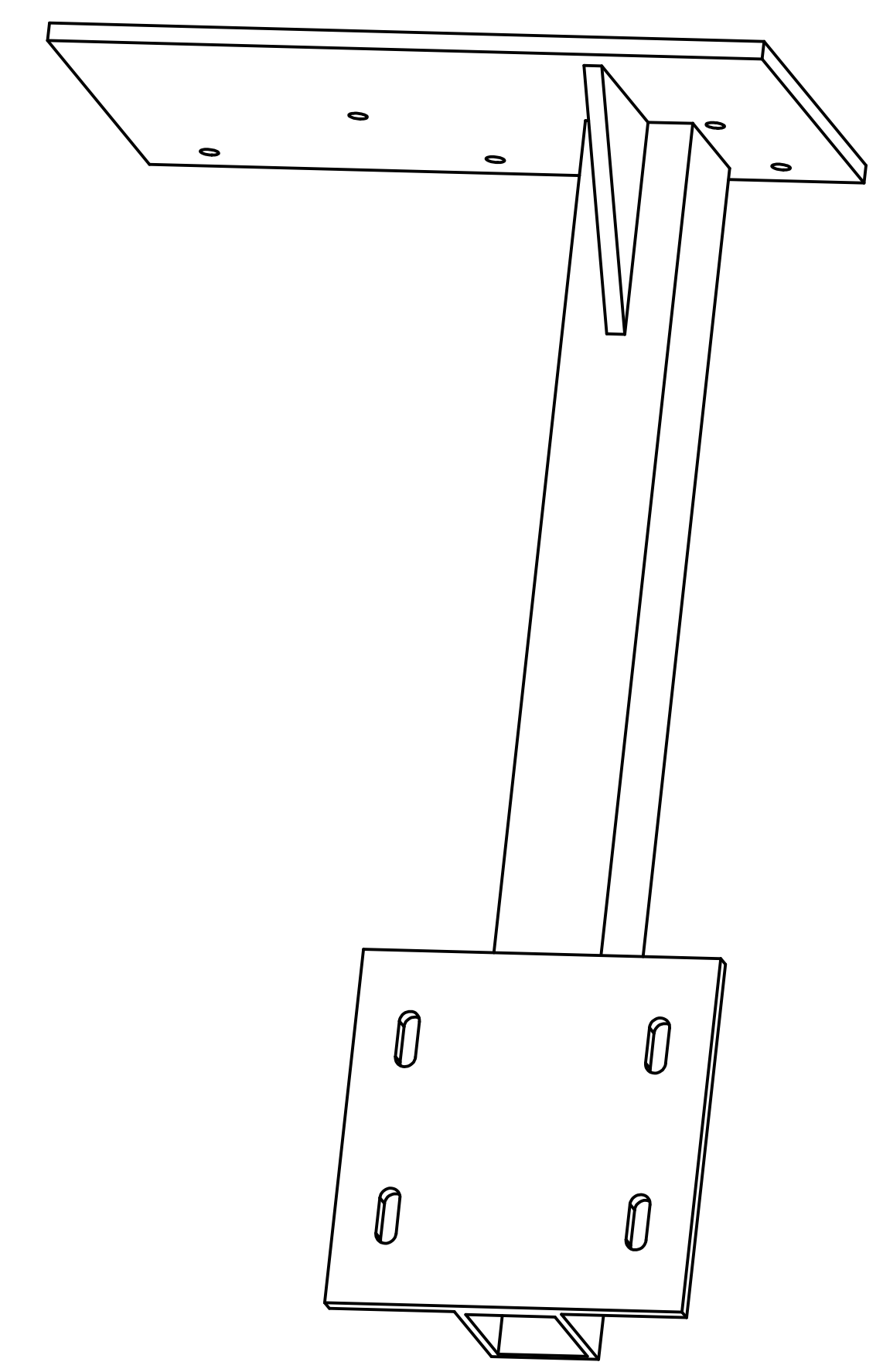
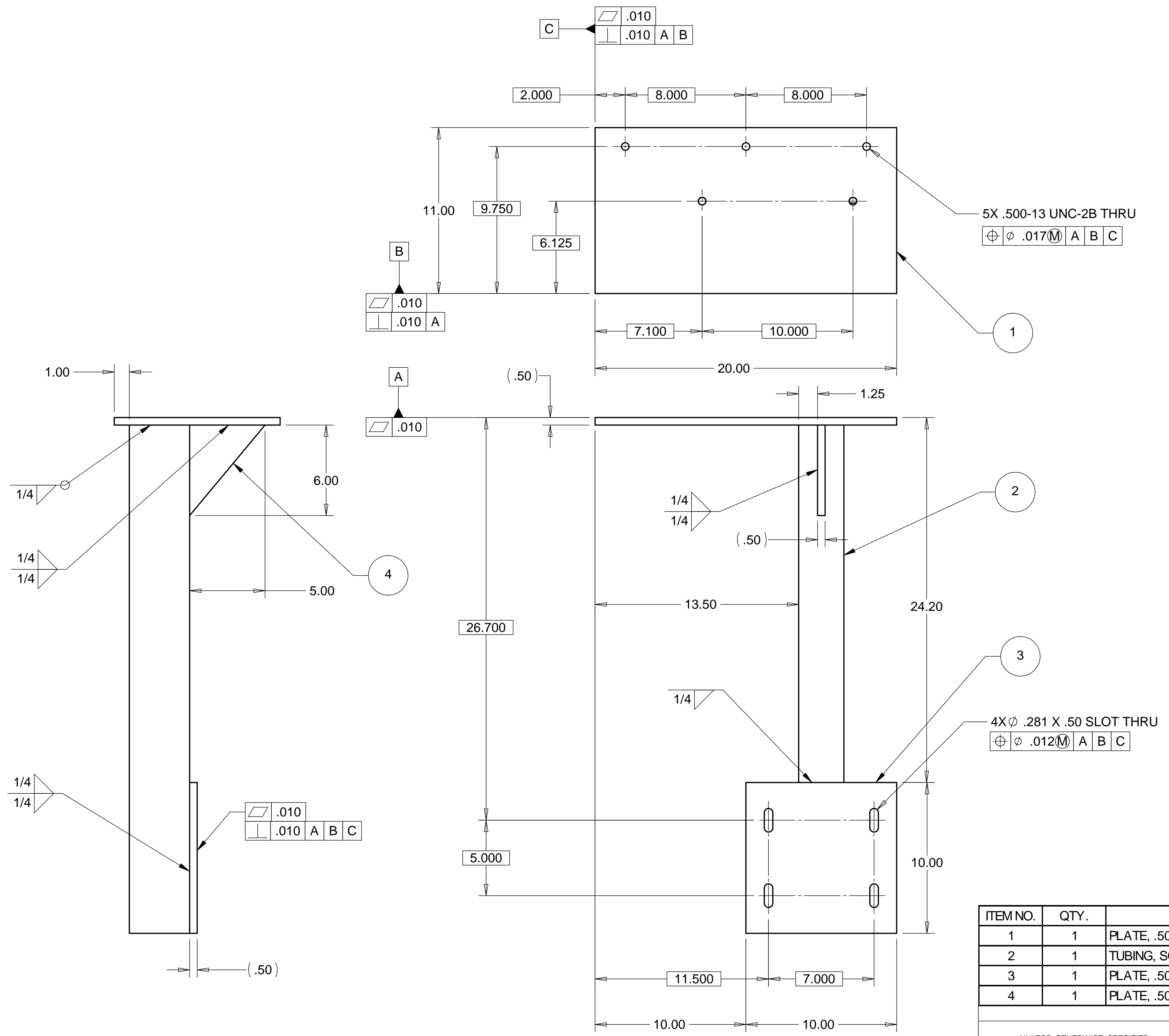

- NOTES: UNLESS OTHERWISE SPECIFIED
1. ALL DIMENSIONS IN INCHES
 2. DIMENSIONS AND TOLERANCING PER ANAS1 Y14.5M-1994
 3. SURFACE TEXTURE PER ANI/ASME B 46.1-1985
 4. REMOVE ALL BURRS AND BREAK SHARP EDGES TO A MAXIMUM OF .015
 5. ALL INSIDE CORNERS TO BE .015 RADIUS MAX
 6. COUNTERSINK 82 DEGREES ALL TAPPED HOLES TO MAJOR DIAMETER
 7. COUNTERSINK 82 DEGREES APPROXIMATELY .015 DEEP ALL DRILLED HOLES
 8. PARTS TO BE THOROUGHLY CLEANED TO REMOVE ALL OIL, GREASE, DIRT AND CHIPS
 9. PART NUMBER (DRAWING NO. PLUS DASH NO. PLUS SERIAL NO.) TO BE CLEARLY MARKED ON THE PART ITSELF.

WEIGHT: 79.45 lbs

ITEM NO.	QTY.	DESCRIPTION	MATERIAL
1	1	PLATE, .500 THK.	304 EZ CUT STAINLESS STEEL
2	1	TUBING, SQUARE 4.00 X 4.00 X .25 WALL	304 EZ CUT STAINLESS STEEL
3	1	PLATE, .500 THK.	304 EZ CUT STAINLESS STEEL
4	1	PLATE, .500 THK.	304 EZ CUT STAINLESS STEEL

PARTS LIST				HYTEC, INC	
UNLESS OTHERWISE SPECIFIED: DIMENSIONS ARE IN INCHES -TOLERANCES-		CAD GENERATED DRAWING, DO NOT MANUALLY UPDATE DO NOT SCALE DRAWING		TITLE BSC SUPPORT BRACKET LEFT SIDE WELDMENT	
DECIMALS X = +/- .1 .XX = +/- .03 .XXX = +/- .010	ANGULAR = +/- .30° SURFACE FINISH = 250	FINISH	SIGNATURE	DATE	DWG. NO.
PART NO. D972433-1		DESIGNED W. K. MILLER	HARRY SALAZAR	2-1-98	SIZE D
		DRAWN GERALD BUSTOS	T. THOMPSON	2-1-98	SHEET NO. 1 of 1
		CHECKED HARRY SALAZAR	T. THOMPSON	----	SCALE 1/4
		ENGR. T. THOMPSON	----	----	REVISION
		APPROVED T. THOMPSON	----	----	

8 7 6 5 4 3 2 1